

USB to CF/ATA/ATAPI Interface Controller, Mass Storage Class Compliant

1 General Description

This chip provides a high-performance interface to bridge USB and CF/ATA/ATAPI compliance device. It provides a flexible and low cost single chip solution for applications intended to utilize the convenience of USB. The DMA/Ultra DMA feature is not supported since the bottleneck in data transfer between ATA device and USB is on the USB side, therefore, DMA transfer is not needed. The external serial EEPROM gives users the possibility to customize their USB identity, i.e., the user could modify the vendor/product ID and vendor/product name for various version of products and stores them in the external EEPROM. This controller chip could be used to connect IDE hard disk, CD-ROM, or Compact Flash memory card.

The USB Mass Storage Class compliance capability of this chip makes it a truly “plug-and-play” device without vendor drivers needed under the OS supporting Mass Storage Class like Windows 2000/ME/XP and Mac OS 9/10. This feature not only makes the system developing fast and easier, but also reduces the cost and increases the reliability of the final products.

For OEM makers who wish to develop their own special functions and application to unquify their products, SN11011 also provides a special vendor-specific mode for the USB host (PC) to directly communicate with the devices without being blocked by the built-in firmware. This unique 2 modes architecture (class and vendor-specific) not only let the system designers to build standard products easily but also provide a simple method to design their own unique product features.

2 Features

Unique 2 modes architecture combines fast developing time and product differentiation together

USB 1.1 standard compatible.

USB 1.1 Mass Storage Class compliant

USB Mass Storage Class Bulk-Only Transport 1.0 supported

USB Mass Storage Class SCSI transparent command set supported

12 characters of serial number and up to 28 characters of Vendor/Product/Revision supported with external EEPROM to uniquely identify each product



Support ATA/ATAPI, PIO mode

Built-in FIFO for upstream and downstream data transfer

Data transfer rate up to 1.5 MB/s (burst), 1 MB/s (read average),

Pin selectable bus-power or self-power

LED lightening pin available.

No Driver needed under Microsoft Windows ME/2000/XP, Mac OS 9.x/10.x

Drivers support Microsoft Windows 98

Single 3.3V operation

48 pin LQFP package.

3 Pin Assignment

PAD Pin#	Pin Name	Type	Drive	Description
1	AVDD	P	-	Analog power supply
2	AVSS	P	-	Analog ground
3	DPLUS	AIO	-	USB D+ signal
4	DMINUS	AIO	-	USB D- signal
5	ATADD3	DIO	8mA, TTL	ATA data bit 3
6	ATADD11	DIO	8mA, TTL	ATA data bit 11
7	ATADD4	DIO	8mA, TTL	ATA data bit 4
8	ATADD12	DIO	8mA, TTL	ATA data bit 12
9	ATADD5	DIO	8mA, TTL	ATA data bit 5
10	ATADD13	DIO	8mA, TTL	ATA data bit 13
11	ATADD6	DIO	8mA, TTL	ATA data bit 6
12	VDD	P	-	3.3V digital power
13	VSS	P	-	3.3V digital ground
14	ATADD14	DIO	8mA, TTL	ATA data bit 14
15	ATADD7	DIO	8mA, TTL, PD	ATA data bit 7
16	ATADD15	DIO	8mA, TTL	ATA data bit 15
17	ATACS0	DO	8mA, TTL	ATAPI chip select 0
18	VSS	P	-	3.3V digital ground
19	VDD	P	-	3.3V digital power
20	ATACS1	DO	8mA, TTL	ATAPI chip select 1
21	ATANIOR	DO	8mA, TTL	ATAPI I/O read signal, active low
22	ATANIOW	DO	8mA, TTL	ATAPI I/O write signal, active low

23	ATAIRDY	DI	TTL, PU	ATAPI data ready signal, active high
24	ATADA2	DO	8mA, TTL	ATAPI device address 2
25	ATADA1	DO	8mA, TTL	ATAPI device address 1
26	ATADA0	DO	8mA, TTL	ATAPI device address 0
27	ATADD0	DIO	8mA, TTL	ATA data bit 0
28	ATADD1	DIO	8mA, TTL	ATA data bit 1
29	ATADD8	DIO	8mA, TTL	ATA data bit 8
30	ATADD2	DIO	8mA, TTL	ATA data bit 2
31	VSS	P	-	3.3V digital ground
32	VDD	P	-	3.3V digital power
33	ATADD9	DIO	8mA, TTL	ATA data bit 9
34	ATADD10	DIO	8mA, TTL	ATA data bit 10
35	XIN	I	-	Crystal input or oscillator input
36	XOUT	O	-	Crystal output or no connection
37	SELPWR	DI	-	Power select pin; 0:Bus power 1: self power
38	ROMSK	DO	4mA, TTL	Clock for external serial EEPROM
39	ROMCS	DO	4mA, TTL	Chip select for external EEPROM
40	ROMDI	DO	4mA, TTL	Serial data to external EEPROM
41	ROMDO	DI	4mA, TTL, PD	Serial data from external EEPROM
42	LED	DIO	8mA, PD	LED lighter
43	CD	DIO	8mA, PU	Card Detect
44	TEST	DI	PD	Test mode
45	RSTN	DI	PU	Bridge reset
46	PWRSW	DO	8mA, OC	Power down control
47	ATARSTN	DO	8mA, TTL	ATA reset, active low
48	ATAINTR	DI	TTL	ATA interrupt request

- P: power pin; AI: analog input pin, AIO: analog input/output pin; DI: digital input pin; DO: digital output pin; DIO: digital input/output pin.
- TTL: TTL compatible input pin; PD: pull down; PU: pull up.
- All pads are Schmitt triggered and with slew rate control

4 Block Diagram

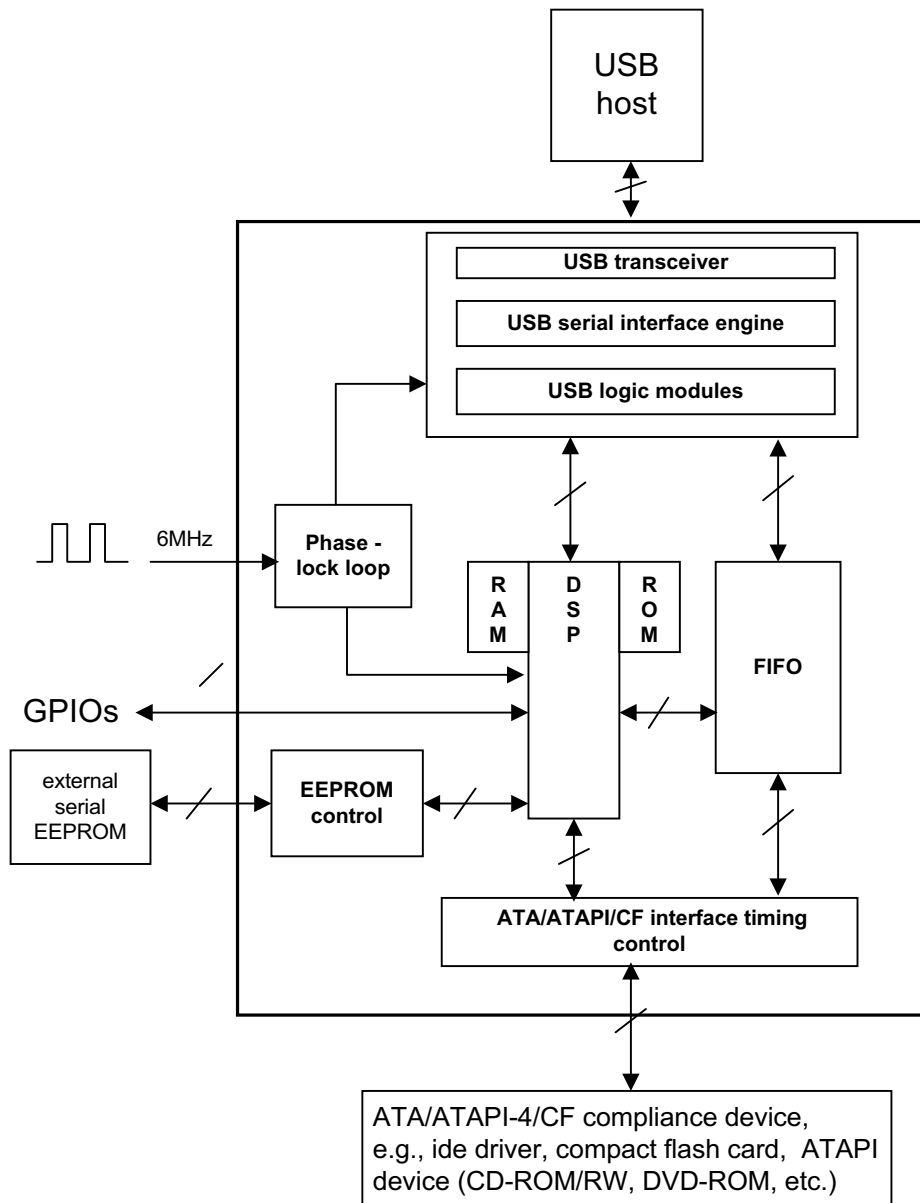

5 Operating Description

5.1 USB Descriptor

This bridge supports two device descriptors, one for each operating mode. Each device descriptor comes with one configuration and one interface descriptor. There are three endpoints within the interface. Endpoint 0 is the default control endpoint. Endpoint 1 is the Bulk-in endpoint (data from device to host) and endpoint 2 is the Bulk-out endpoint (data from host to device).

5.1.1 Class Device Descriptor

Offset	Field	Size	Value	Descriptor
0	blength	Byte	12H	Size of this descriptor in byte
1	bdescriptorType	Byte	01H	DEVICE descriptor type
2	bcdUSB	Word	0110H	USB specification version 1.1
4	bdeviceClass	Byte	00H	Interface specific
5	bdeviceSubClass	Byte	00H	Interface specific
6	bdeviceProtocol	Byte	00H	Interface specific
7	bmaxPacketSize	Byte	40H	Maximum packet size for endpoint zero is 64
8	idVendor	Word	Note 1	Vendor ID
10	idProduct	Word	Note 1	Product ID
12	bcdDevice	Word	0100H	Device release 1.0
14	imanufacture	Byte	00H	Null
15	iproduct	Byte	00H	Null
16	iserialNumber	Byte	Note 2	Index of serial number (details in 5.1.1.1 below)
17	bnumConfigurations	Byte	01H	One possible configuration

- Note 1: These values can be changed by external EEPROM or the SELPWR/ROMDO configuration (when no external EEPROM exists), please refer to section 5.4
- Note 2: These values depends on the content of external EEPROM, please refer to section 5.4

5.1.1.1 Serial Number Format

The host may generate a globally unique identifier by maintaining the 16 bit idVendor, the 16 bit idProduct, and the value represented by the last 12 characters of the string descriptor indexed by iSerialNumber.

The field iSerialNumber is an index to a string descriptor and does not contain the string itself. The format for the string descriptor of SN11011 is shown below.

Offset	Field	Size	Value	Descriptor
0	blength	Byte	1AH	Size of this descriptor in bytes
1	bdescriptorType	Byte	03H	STRING descriptor type
2	wstring1	Word	0030H	Serial number character 1, ASCII "0"
4	wstring2	Word	0030H	Serial number character 2, ASCII "0"
6	wstring3	Word	0030H	Serial number character 3, ASCII "0"
8	wstring4	Word	0033H	Serial number character 4, ASCII "3"
10	wstring5	Word	0030H	Serial number character 5, ASCII "0"
12	wstring6	Word	0030H	Serial number character 6, ASCII "0"
14	wstring7	Word	0031H	Serial number character 7, ASCII "1"
16	wstring8	Word	0033H	Serial number character 8, ASCII "3"
18	wstring9	Word	0030H	Serial number character 9, ASCII "0"
20	wstring10	Word	0030H	Serial number character 10, ASCII "0"
22	wstring11	Word	0032H	Serial number character 11, ASCII "2"
24	wstring12	Word	0034H	Serial number character 12, ASCII "4"

The following table defines the valid characters that the device shall use for the serial number.

Numeric	ASCII
0030H through 0039H	"0" through "9"
0041H through 0046H	"A" through "F"

The serial number string feature can be disabled by the users who do not want to have an external EEPROM on their systems. This is done by pull-up ROMDO to logical level high. For users who like to have this feature turned on, they must put an external EEPROM on their systems and follow the application documents: *"External EEPROM for SN11011"*.

5.1.1.2 VID and PID without EEPROM

The VID and PID can be changed to any arbitrary values the user wants by using an external EEPROM. For the users who would like to save the system cost, SN11011 also provides some flexibility in choosing the PID. The default VID for SN11011 is 0x0C45 (for SONiX) and cannot be changed except with external EEPROM installed. The PID can be changed to by pull ROMDO and SELPWR pins to different logical levels, as the following table.

{ROMDO, SELPWR}	{0,0}	{0,1}	{1,0}	{1,1}
PID	0x1020	0x1028	0x1050	0x1058

Please be noted that when the user pull down the ROMDO (PID = 0x1020/0x1028), then the serial number string feature is enabled. If the user does not put a serial EEPROM on the system, then all the system will have an identical serial number string, which is 000000000000. This configuration is not recommended.

5.1.2 Class Configuration Descriptor

Offset	Field	Size	Value	Descriptor
0	bLength	Byte	09H	Size of this descriptor in bytes
1	bDescriptor	Byte	02H	CONFIGURATION descriptor type
2	bTotalLength	Word	0020H	
4	bNumInterface	Byte	01H	The bridge has one interface
5	bConfigurationValue	Byte	01H	
6	iConfiguration	Byte	00H	Null
7	bmAttributes	Byte	E0H/ A0H	Bus/self powered; depends on SELPWR. For Bus power: A0H, For Self power: E0H
8	MaxPower	Byte	32H	Support up to 100 mA of current

5.1.3 Class Interface Descriptor

Offset	Field	Size	Value	Descriptor
0	bLength	Byte	09H	Size of this descriptor in bytes
1	bDescriptor	Byte	04H	INTERFACE descriptor type
2	bInterfaceNumber	Byte	00H	Interface 0
3	bAlternateSetting	Byte	00H	
4	bNumEndpoint	Byte	02H	Support endpoint 0, 1, 2
5	bInterfaceClass	Byte	08H	Mass Storage Class
6	bInterfaceSubClass	Byte	06H	SCSI transparent command set
7	bInterfaceProtocol	Byte	50H	Bulk-Only Transport protocol
8	iInterface	Byte	00H	

5.1.4 Vendor Device Descriptor

Offset	Field	Size	Value	Descriptor
0	blength	Byte	12H	Size of this descriptor in byte
1	bdescriptorType	Byte	01H	DEVICE descriptor type

2	bcdUSB	Word	0110H	USB specification version 1.1
4	bdeviceClass	Byte	00H	Interface specific
5	bdeviceSubClass	Byte	00H	Interface specific
6	bdeviceProtocol	Byte	00H	Interface specific
7	bmaxPacketSize	Byte	40H	Maximum packet size for endpoint zero is 64
8	idVendor	Word	Note7.1.1	Vendor ID
10	idProduct	Word	Note7.1.1	Product ID
12	bcdDevice	Word	0100H	Device release 1.0
14	imanufacture	Byte	00H	Null
15	iproduct	Byte	00H	Null
16	iserialNumber	Byte	00H	Null
17	bnumConfigurations	Byte	01H	One possible configuration

□ Note7.1.1: These values depends on the content of external EEPROM and the SELPWR configuration

5.1.5 Vendor Configuration Descriptor

Offset	Field	Size	Value	Descriptor
0	bLength	Byte	09H	Size of this descriptor in bytes
1	bDescriptor	Byte	02H	CONFIGURATION descriptor type
2	bTotalLength	Word	0020H	
4	bNumInterface	Byte	01H	The bridge has one interface
5	bConfigurationValue	Byte	01H	
6	iConfiguration	Byte	00H	Null
7	bmAttributes	Byte	E0H/ A0H	Bus/self powered; depends on SELPWR. For Bus power: A0H, For Self power: E0H
8	MaxPower	Byte	32H	Support up to 100 mA of current

5.1.6 Vendor Interface Descriptor

Offset	Field	Size	Value	Descriptor
0	bLength	Byte	09H	Size of this descriptor in bytes
1	bDescriptor	Byte	04H	INTERFACE descriptor type
2	bInterfaceNumber	Byte	00H	Interface 0
3	bAlternateSetting	Byte	00H	
4	bNumEndpoint	Byte	02H	Support endpoint 0, 1, 2
5	bInterfaceClass	Byte	FFH	Vendor specific
6	bInterfaceSubClass	Byte	FFH	Vendor specific ass
7	bInterfaceProtocol	Byte	FFH	Vendor specific

8	iInterface	Byte	00H	
---	------------	------	-----	--

5.1.7 Bulk-in Endpoint Descriptor

Offset	Field	Size	Value	Descriptor
0	bLength	Byte	07H	Size of this descriptor in bytes
1	bDescriptor	Byte	05H	ENDPOINT Descriptor Type
2	bEndpointAddress	Byte	81H	In Endpoint 1
3	bmAttributes	Byte	02H	This is a Bulk endpoint
4	wMaxPacketSize	Word	0040H	Maximum packet size is 64 bytes
6	bInterval	Byte	00H	Does not apply to bulk endpoints

5.1.8 Bulk-out Endpoint Descriptor

Offset	Field	Size	Value	Descriptor
0	bLength	Byte	07H	Size of this descriptor in bytes
1	bDescriptor	Byte	05H	ENDPOINT Descriptor Type
2	BEndpointAddress	Byte	02H	out Endpoint 2
3	BmAttributes	Byte	02H	This is a Bulk endpoint
4	WMaxPacketSize	Word	0040H	Maximum packet size is 64 bytes
6	BInterval	Byte	00H	Does not apply to bulk endpoints

5.2 Requests

In addition to the standard USB device request, 2 class and 4 vendor specific requests are also supported to facilitate the data transfer to or from the external device. Each set of requests can only be operated under mode it is belonged to.

5.2.1 Standard USB Device Request

bmRequestType	Request	wValue	wIndex	wLength	Data
0000000B 00000010B	CLEAR_FEATURE	Feature Selector	Zero Endpoint	Zero	None
1000000B	GET_CONFIGURATION	Zero	Zero	One	Configuration Value
1000000B	GET_DESCRIPTOR	Descriptor Type & Descriptor Index	Zero	Descriptor Length	Descriptor
1000001B	GET_INTERFACE	Zero	Interface	One	Alternate Interface

10000000B	GET_STATUS	Zero	Zero	Two	Device Status
10000001B			Interface		Interface Status
10000010B			Endpoint		Endpoint Status
00000000B	SET_ADDRESS	Device Address	Zero	Zero	None
00000000B	SET_CONFIGURATION	Configuration Value	Zero	Zero	None
00000000B	SET_FEATURE	Feature Selector	Zero	Zero	None
00000010B			Endpoint		
00000001B	SET_INTERFACE	Alternate Setting	Interface	Zero	None

5.2.1.1 Standard Request Codes

bRequest	Value	bRequest	Value
GET_STATUS	0	GET_CONFIGURATION	8
CLEAR_FEATURE	1	SET_CONFIGURATION	9
SET_FEATURE	3	GET_INTERFACE	10
SET_ADDRESS	5	SET_INTERFACE	11
GET_DESCRIPTOR	6		

5.2.1.2 Descriptor Types

Descriptor Types	Value
DEVICE	1
CONFIGURATION	2
INTERFACE	4
ENDPOINT	5

5.2.1.3 Feature Selectors

Feature Selector	Recipient	Value
DEVICE_REMOTE_WAKEUP	Device	1
ENDPOINT_HALT	Endpoint	0

5.2.2 Class Specific Request

The chip supports 2 class specific requests mandatory for USB Mass Storage Class Bulk-Only Transport protocol devices.

5.2.2.1 Class Specific Request

bmRequestTyp	bRequest	wValue	wIndex	wLength	Data
00100001B	BULK-ONLY MASS STORAGE	0000H	Interface	0000h	none
10100001B	GET MAX LUN	0000H	Interface	0000h	1 byte

5.2.2.2 Class Specific Request Codes

bRequest	Value
BULK-ONLY MASS STORAGE RESET	FFH
GET MAX LUN	FEH

5.2.3 Vendor Specific Request

This bridge provides 4 vendor specific requests to bypass the internal firmware and directly control the function of the bridge and the external ATA/ATAPI/CF device through the control transfer. For details, please refer to the application document: “*Vendor Specific Requests for SN11011*”.

5.3 Mass Storage Class Protocol & Command Set

5.3.1 Mass Storage Class Protocol Implemented

The protocol implemented in SN11011 is Bulk-only transport. Please refer to the USB Mass Storage Class Bulk-Only Transport spec. v1.0 for detail.

5.3.2 Mass Storage Subclass Code Implemented

The subclass code implemented in SN11011 is SCSI transparent command set. Please refer to SPC-2 for detail.

5.4 EEPROM contents arrangement

The SN11011 supports an external EEPROM (93C46) to be installed for the system manufacturers to customize the USB VID, PID, serial number and the strings being displayed in the OS to differentiate their own products with others. For the details about EEPROM content, please refer to the application document: “*External EEPROM for SN11011*”.

6 Timing

6.1 ATA/ATAPI Interface

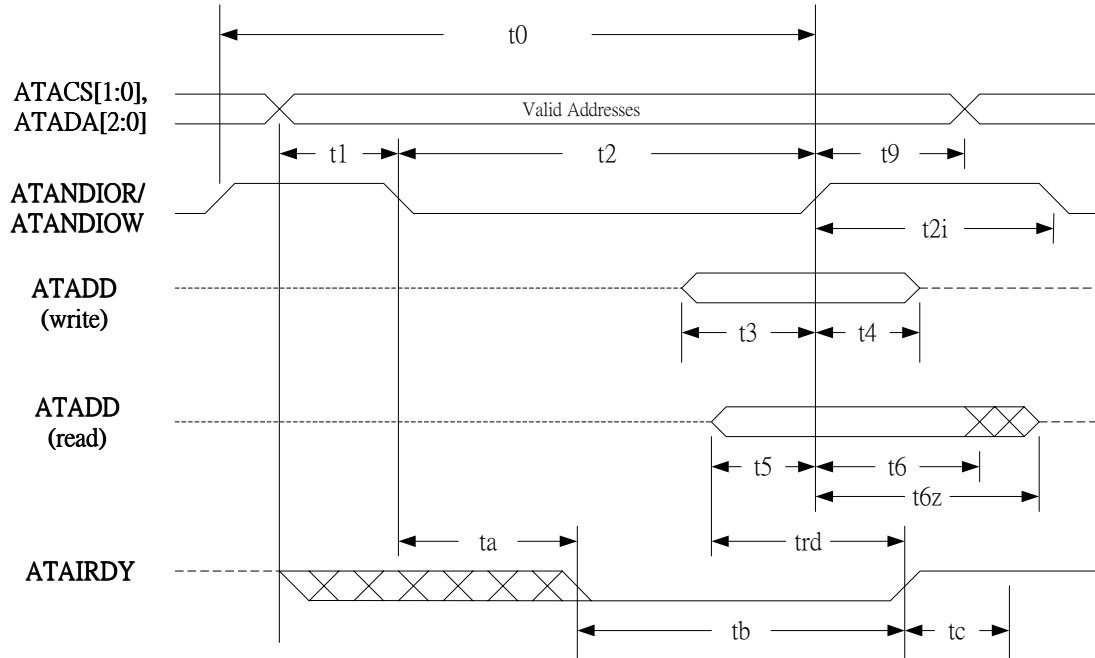

6.2 EEPROM Interface

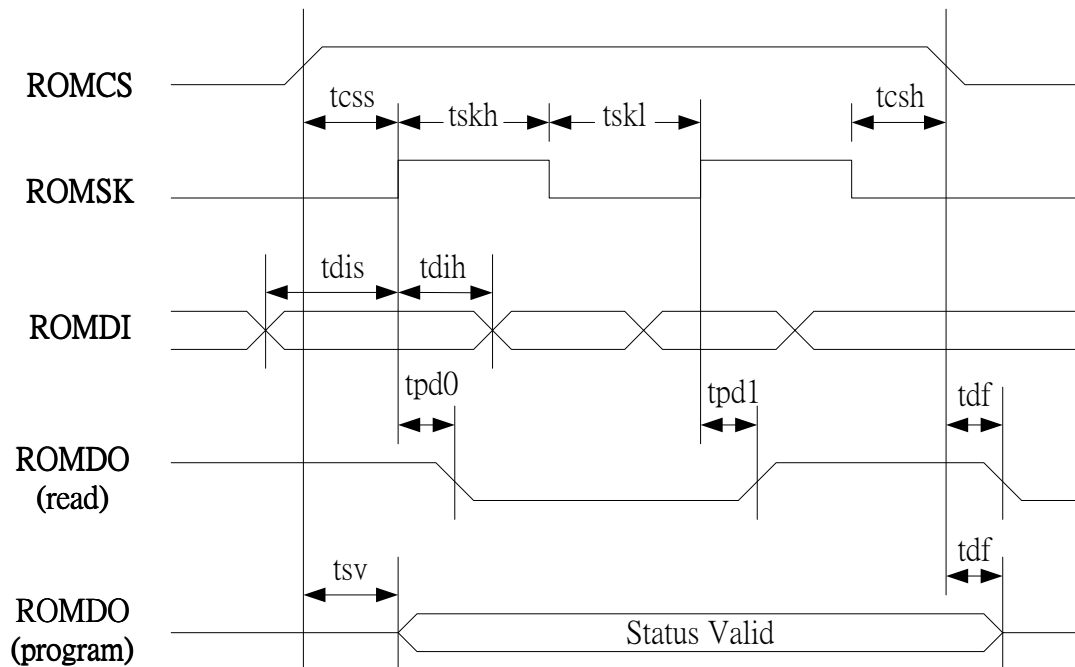

6.3 USB Interface

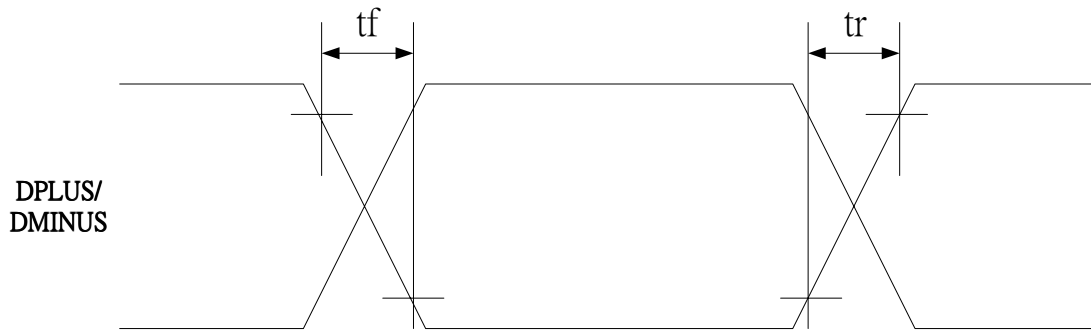

7 Electrical Characteristics

7.1 Absolute maximum rating

symbol	parameter	value	unit
DVmin	min digital supply voltage	DGND - 0.3	V
DVmax	max digital supply voltage	DGND + 4.6	V
AVmin	min analog supply voltage	AGND - 0.3	V
AVmax	max analog supply voltage	AGND + 4.6	V
DVinout	voltage on any digital input or output pin	DGND -0.3 to 5.5	V
AVinout	voltage on any analog input or output pin	AGND -0.3 to Avdd + 0.3	V
T _A	storage temperature range	-40 to +125	C
ESD (HBM)	ESD human body mode	2000	V
ESD (MM)	ESD machine mode	200	V
I _{off}	Leakage current	10	uA
I _{latch}	Minimum latch up current	100	mA

7.2 Operation conditions

symbol	parameter	value	unit
DVdd	digital supply voltage	+3 to +3.6	V

Avdd	analog supply voltage	+3 to +3.6	V
T _A	operating temperature range	0 to 70	C

7.3AC electrical characteristics

symbol	parameter	value	unit
CLKin	system clock input to PLL	6 (typ)	MHz
	CLKin duty cycle	50 ± 2	%

symbol	parameter	min	max	unit
t _r	Transition rise time from DPLUS or DMINUS	4	20	ns
t _f	Transition fall time from DPLUS or DMINUS	4	20	ns
trfm	Rise/Fall time matching	90	110	%
Vo(crs)	Signal crossover voltage	1.3	2.0	V

symbol	parameter	min	typ	max	unit
t ₀	Cycle time	600	760		ns
t ₁	Address valid to ATANDIOR/ATANDIOW setup time	70	80		ns
t ₂	ATANDIOR/ATANDIOW pulse width	165	320		ns
t _{2i}	ATANDIOR/ATANDIOW recovery time	400			ns
t ₃	ATANDIOW data setup time	60	80		ns
t ₄	ATANDIOW data hold time	30	40		ns
t ₅	ATANDIOR data setup time	50			ns
t ₆	ATANDIOR data hold time	5			ns
t _{6z}	ATANDIOR data tri-state time			30	ns
t ₉	ATANDIOR/ATANDIOW to address valid hold time	20	120		ns
t _{rd}	Read data valid to ATAIRDY active	0			ns
t _a	ATAIRDY setup time	35			ns
t _b	ATAIRDY pulse width			1250	ns
t _c	ATAIRDY assertion to release			5	ns

symbol	parameter	min	typ	max	unit
tsk	ROMSK clock frequency	200	400	500	kHz

tskh	ROMSK high time	500	1200		ns
tskl	ROMSK low time	500	1200		ns
tcs	Minimum ROMCS low time	500	2400		ns
tcss	ROMCS setup time	100	2400		ns
tdis	ROMDI setup time	100	1200		ns
tctsh	ROMCS hold time	0	1200		ns
tdih	ROMDI hold time	200	1200		ns
tpd1	ROMDO delay to "1"			250	ns
tpd0	ROMDO delay to "0"			250	ns
tstv	ROMCS to status valid			250	ns
tdf	ROMCS to ROMDO high impedance			250	ns

7.4 DC electrical characteristics

Symbol	Parameter	Value	Unit
VIH	High level input current	2.0	V
VIL	Low level input current	0.8	V
VOH	High level output voltage	2.0	V
VOL	Low level output voltage	0.8	V

8 Package diagram

LQPF 48 Package

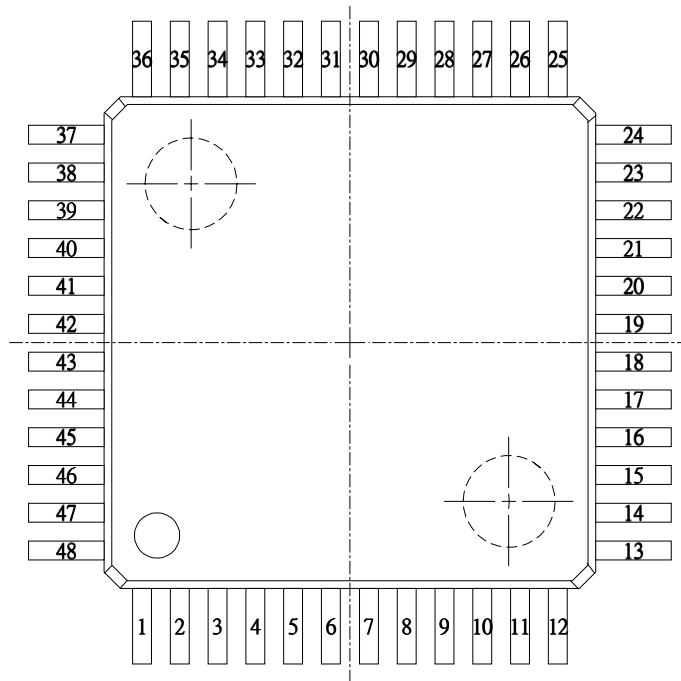

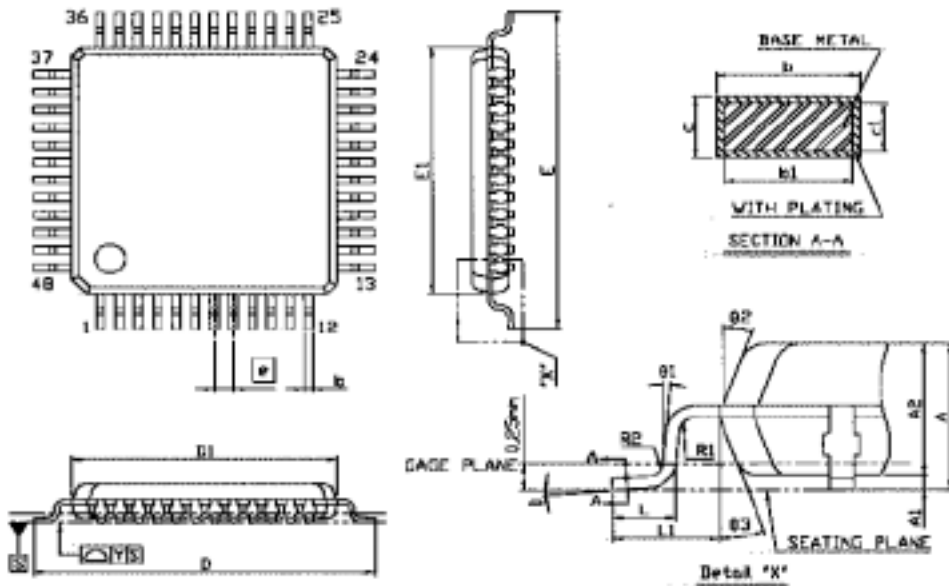

SYMBOL	DIMENSION (MM)			DIMENSION (MIL)		
	MIN.	NOM.	MAX.	MIN.	NOM.	MAX.
A			1.60			63
A1	0.05		0.15	2		6
A2	1.35	1.40	1.45	53	55	57
b	0.17	0.22	0.27	7	9	11
b1	0.17	0.20	0.23	7	8	12
c	0.09		0.20	4		8
c1	0.09		0.16	4		6
D	9.00 BSC			354 BSC		
D1	7.00 BSC			276 BSC		
E	9.00 BSC			354 BSC		
E1	7.00 BSC			276 BSC		
Ø	0.50 BSC			20 BSC		
L	0.45	0.60	0.75	18	24	30
L1	100 REF			39 REF		
R1	0.08			3		
R2	0.08		0.20	3		8
Y			0.075			3
θ	0°	3.5°	7°	0°	3.5°	7°
θ1	0°			0°		
θ2	11°	12°	13°	11°	12°	13°
θ3	11°	12°	13°	11°	12°	13°

NOTE:

1.REFER TO JEDEC MS-026/B9C

2.DIMENSION D1 AND E1 DO NOT INCLUDE MOLD PROTRUSION.

ALLOWABLE PROTRUSION IS 0.25mm PER SIDE D1 AND E1 ARE

MAXIMUM PLASTIC BODY SIZE DIMENSION INCLUDING MOLD MISMATCH.

3.DIMENSION b DOES NOT INCLUDE DAMBAR PROTRUSION. ALLOWABLE

DAMBAR PROTRUSION SHALL NOT CAUSE THE LEAD WIDTH TO EXCEED

THE MAXIMUM b DIMENSION BY MORE THAN 0.08mm.

4.ALL DIMENSIONS IN MILLIMETERS.

9. Version Control

Version 0.1	Dec-21-2001	first release
Version 0.2	Jan-17-2002	add timing diagram
Version 0.3	Jan-29-2002	move vendor request and EEPROM content to application documents
Version 0.4	Feb-06-2002	add LQPF 48 pin package diagram
Version 0.5	Feb-26-2002	add LQPF 48 pin package information