

MAGNETIC PICKUP IGNITION CONTROLLER

- DIRECT DRIVING OF THE EXTERNAL DARLINGTON
- OPERATES WITH A WIDE RANGE OF MAGNETIC PICKUP TYPES
- CHARGING ANGLE (DWELL) CONTROL
- COIL CURRENT PEAK LIMITATION
- CONTINUOUS COIL CURRENT PROTECTION
- TACHOMETER SIGNAL OUTPUT
- EXTERNAL DARLINGTON OVERVOLTAGE PROTECTION
- LOAD DUMP AND REVERSE BATTERY PROTECTION
- POSSIBILITY OF SPARK POINT DELAYING (ANTI KNOCK SYSTEM)

special design which has two input pins from the pickup ; the first is the zero crossing detector for the ignition command and the second pin is used to calculate the dwell time. Moreover another pin is used to adapt the L484 to various pickup types.

Other features of the device include darlington overvoltage protection, dump protection, a supply voltage range of 6-28 V.

DESCRIPTION

The L484 is an integrated circuit designed for use with an NPN darlington in breakerless ignition systems with magnetic pickup sensors and high energy ignition coils.

A key feature of the L484 is flexibility. It can be used with a wide variety of magnetic sensors thanks to the

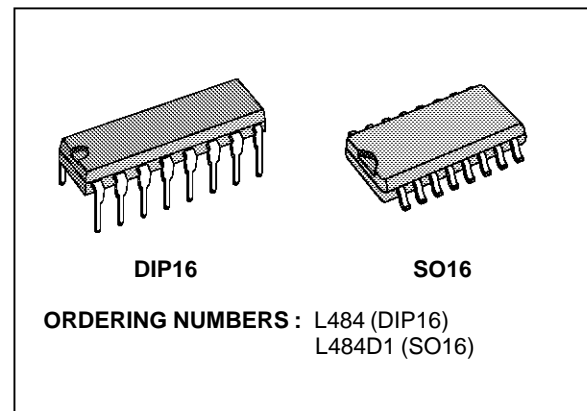

BLOCK DIAGRAM

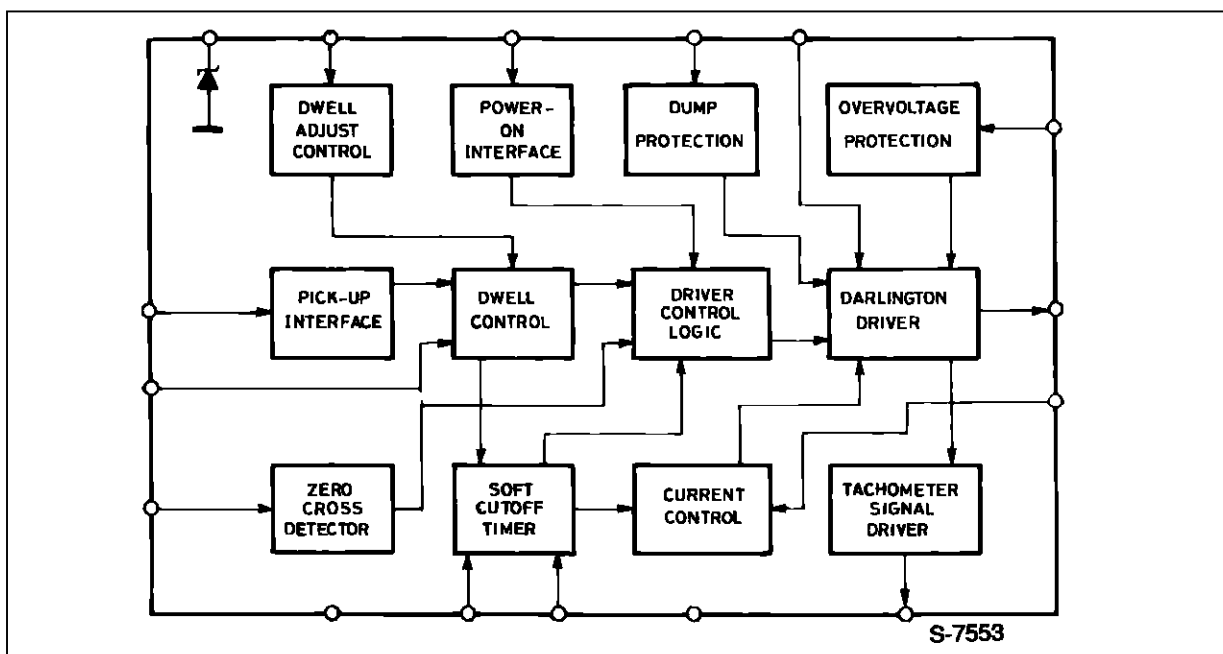

ABSOLUTE MAXIMUM RATINGS

Symbol	Parameter	Value	Unit
V_R	Reverse Battery Voltage	- 14	V
V_D	Dump Voltage	100	V
P_{tot}	Power Dissipation at $T_{amb} = 90^\circ\text{C}$	0.75	W
T_j, T_{stg}	Junction and Storage Temperature Range	- 55 to 150	$^\circ\text{C}$

PIN CONNECTION

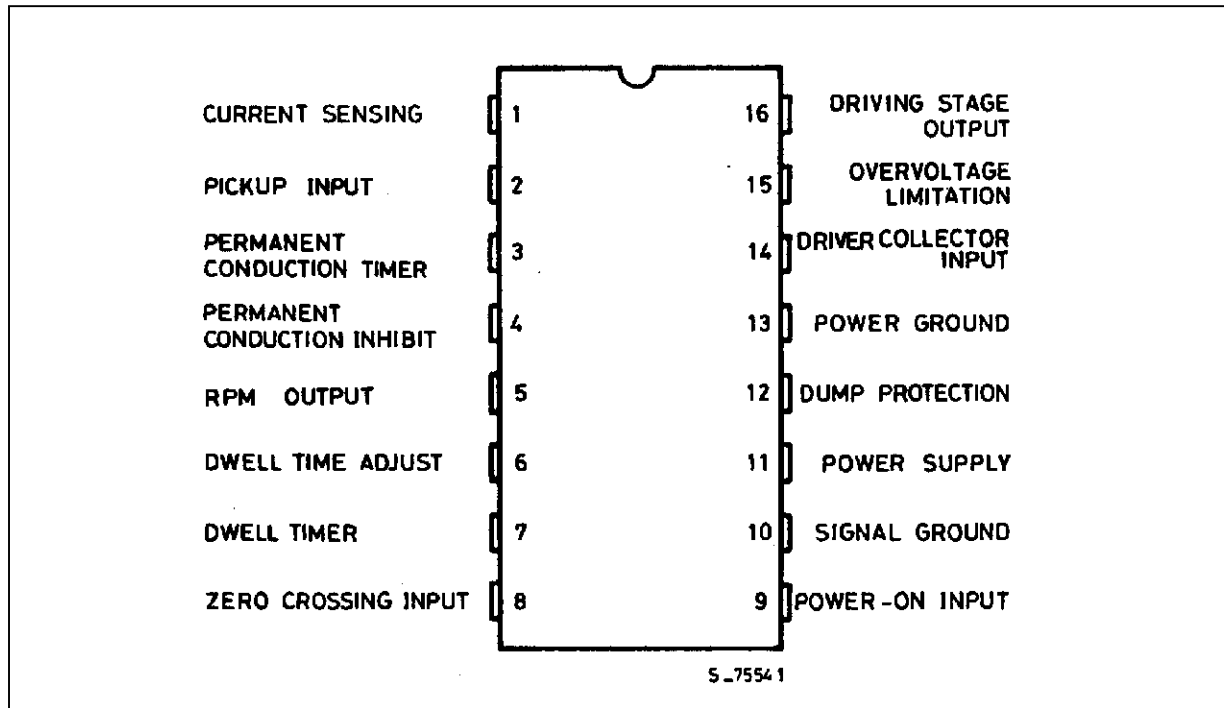

THERMAL DATA

Symbol	Parameter	Value	Unit
$R_{th\ j-amb}$	Thermal Resistance Junction-ambient (DIP16)	Max 80	$^\circ\text{C/W}$
$R_{th\ j-al}$	Thermal Resistance Junction-alumina (SO16)	Max 50	$^\circ\text{C/W}$

PIN FUNCTIONS (refer to fig. 2)

N°	Name	Function
1	CURRENT SENSING INPUT	Connection for Coil Current Limitation. The current is measured on the sense resistor R_{SENS} and divided on $R1/R2$. The current limitation value is given by : $I_{SENS} = \frac{R1 + R2}{R_{SENS} R2}$
2	PICKUP INPUT	Magnetic Pickup Signal Input. This pin sets the dwell time, i.e. the max negative pickup voltage value starting from which the device can drive the current into the coil. The real dwell time will be a function of the dwell control logic. Increasing the resistor $R11$ the maximum conduction time increases. The max input current foreseen is 2mA.
3	PERMANENT CONDUCT. PROTECTION TIMER	A capacitor $C1$ connected between this pin and ground sets the delay of the permanent conduction protection in the coil current. Using a 50nF capacitor the typical desaturation time delay for the protection is 75ms.
4	PERMANENT CONDUCT. PROTECTION INHIBIT	A low level on this input (max 0.7V) disables the protection, irrespective of the state of pin 3. If the protection is used this pin must be left open.
5	RPM OUTPUT	Open collector output signal which is at a low level when the final darlington is in ON status. The current is internally limited at 10mA.
6	DWELL TIME ADJUST	At high motor rotation speeds, i.e. when the peak value of the magnetic pick-up signal exceeds 6V using $R12 = 100K\Omega$, this pin may be used to vary the dwell ratio. Adding a resistor in series R_a between this pin and pin 11 the desaturation time is reduced. It is therefore possible to use this pin to adapt the L484 to various pickup types. The maximum value of the resistor R_a is 200K Ω .
7	DWELL CONTROL TIMER	A capacitor $C2$ connected between this pin and ground sets the timing for the dwell control. The recommended value is 100nF. The resistors R_b/R_c provide an hysteresis to confirm ON state and avoid spurious sparks.
8	ZERO CROSSING INPUT	Zero cross detector input of the magnetic pickup signal for the ignition actuation. At high motor rotation speeds, the external resistor $R12$ may be used to vary the desaturation time ratio, to adapt the L484 to various signal waveforms of time magnetic pick-up. Reducing the resistor value the dwell time increases. Typically the range of values for resistor $R12$ is from 50K Ω to 150K Ω .
9	POWER-ON INPUT	A low level on this pin forces the external darlington into conduction particularly useful in anti knock system. This function is particularly useful in antiknock system because provides a spark time delay. Anyway the current limitation, the permanent conduction protection and the dump protection are operating even when pin 9 is at a low level. If this function is not used it must be left open.
10	SIGNAL GROUND	This pin must be connected to ground.
11	POWER SUPPLY	Supply Voltage Input. A 7V (typ) zener is present at the input. The external resistor $R9$ limits the current through the zener for higher supply voltages.
12	DUMP PROTECTION	The device is protected against the load dump. In load dump condition an internal circuit, based on a zener diode and a darlington transistor, switches off the external darlington and short circuits the supply. By means of the external divider $R8/R9$ the protection threshold can be changed and is given as first approximation by: $V_{Dth} = 8.5 \left(\frac{R8 + R9}{R9} \right) + 5 \cdot 10^{-4} R8$ (the resistor $R9$ value must be higher than 4K Ω).
13	POWER GROUND	This pin must be connected to ground.

* this function is particularly useful in antiknock systems because provides a spark time delay. Anyway the current limitation, the permanent conduction protection and the dump protection are operating even when pin 9 is at a low level.

PIN FUNCTIONS (continued)

N°	Name	Function
14	DRIVER COLLECTOR INPUT	The collector current for the internal driver which drives the external darlington is supplied through this pin. The external resistor R10 limits the dissipation in the IC. The value this resistor depends on the darlington used and on the limiting current in the coil.
15	OVERVOLTAGE LIMITATION	The external darlington is protected against overvoltage by means of an internal zener available at this pin. The external divider R5/R6 defines the limitation value, typically given by : $V_{ovp} = \left(\frac{30}{R5} + 5 \cdot 10^{-3} \right) \cdot R6 + 30$
16	DRIVING STAGE OUTPUT	Current Driver for the External Darlington. To ensure stability on the current limitation loop a capacitor C3 (typically 2.2nF, this value depending on the darlington used) must be connected between this pin and the current sensing input (pin 1).

ELECTRICAL CHARACTERISTICS ($V_S = 14.4V$; $T_J = -40$ to $125^\circ C$ unless otherwise specified ; referred to the test circuit)

Symbol	Parameter	Test Conditions	Min.	Typ.	Max.	Unit
V_S	Operating Supply Voltage		6		28	V
V_{IS}	Input Stage Voltage (pin 2 with 10K Ω resistor)		160	200	240	mV
V_{TH}	On Pick-up Thresh. Voltage at LOW RPM (pin 2)		$V_{IS}-30$		$V_{IS}+30$	mV
V_{SENS}	Current Limitation Sensing Voltage (pin 1)	$V_S = 6$ to $16V$	200		320	mV
V_{ZC}	Zero Crossing Thresh. Voltage (pin 8)		3	20	60	mV
V_H	Hysteresis Voltage (pin 8)		100		200	mV
I_{7C}	$C_{D\ WELL}$ Charge Current	at LOW RPM	0.7		3	μA
I_{7D}	$C_{D\ WELL}$ Discharge Current	$V_{pick-up} = 0.5V$; or pin 6 not connected (*) Note 1	7		30	μA
I_{7D}/I_{7C}			7		15	
I_{7C}	$C_{D\ WELL}$ Charge Current	at HIGH RPM	8		33	μA
I_{7D}	$C_{D\ WELL}$ Discharge Current	$V_{pick-up} = 9V$	13		44	μA
I_{7D}/I_{7C}		(**) Note 2	0.7		3.2	
V_{pin3}	Threshold Voltage	$T_{amb} = 25^\circ C$	0.85		4	V
I_3	Output Current	(***) Note 3			3	μA
V_{Cp}	Continuous Coil Current Protection Inhibit LOW Voltage (pin 4).		0		0.7	V
V_{CEsat}	Series Darlington Driver Saturation Voltage ($V_{pin\ 14 - 16}$)	$I_{pin14} = 150mA$ $I_{pin14} = 50mA$		0.4	1	V
V_Z	Zener Volt. Pin 11	$I_{pin11} = 140mA$	6.5		8.8	V
V_{OVZ}	External Darlington Overvoltage Protection Zener Voltage	$T_{amb} = 25^\circ C$; $I_{pin15} = 5$ to $15mA$	25		35	V
I_{og}	Pin 9 Output Current in Low Status	$V_9 = 0V$			3	mA
V_{CH}	Tachometer Signal Output LOW Voltage. (pin5)	ON Condition			0.7	V
I_{CH}	Output Leakage (pin 5)	$I_{sink} = 0.5mA$ OFF Condition $V_{pin5} = 5V$			10	μA

DUMP PROTECTION

Symbol	Parameter	Test Conditions	Min.	Typ.	Max.	Unit
V _{DZ}	Zener Dump (pin 12)	I _{pin12} = 2mA	7.5		9.5	V

(*) Note 1 : TD/T is given by the formula :

$$\frac{TD}{T} = \frac{1}{1 + I7D/I7C}$$

(**) Note 2 :

$$\frac{TD}{T} = \frac{K}{1 + I7D/I7C}$$

K value depends on the pick-up used in the application ; typically K = 0.1

(***) Note 3 : the permanent conduction protection is guaranteed over the full temperature range

CIRCUIT OPERATION

The L484 controls the charging angle (dwell) and the peak value of the primary current in the coil over the full range of operating conditions.

The coil current is limited to a predetermined level by means of a negative feedback circuit including a current sensing resistor, a comparator, the driver stage and the power switch.

The dwell control circuit keeps the output stage in its active region during current limitation. The time the output stage is operating in the active region (desaturation time), is sufficient to compensate for possible variation in the energy stored due to the acceleration of the motor ; moreover this time is limited to avoid excessive power dissipation.

MAGNETIC PICK-UP CHARACTERISTICS

The typical magnetic pickup waveforms are shown in fig. 1, the amplitude of the signal being a function of the frequency. However on the market there are many types of magnetic pickup, of which the waveforms may differ very much. Adjusting the value of the resistor R₁₁ on pin 2 and/or adding a resistor R_a between the pin 6 (dwell adjust) and pin 11, as shown in the application circuit, it is possible to adapt the L484 to a wide range of magnetic pickup waveforms.

Particularly by means of the resistor R₁₁ on pin 2 it is possible to define the maximum advance of the conduction start into the coil . This is very useful at high pick-up frequency.

CONTROL OF THE DWELL ANGLE

The dwell angle control circuit defines the conduction time of the output darlington, versus the speed of rotation, the supply voltage and the characteristics of the coil.

In each cycle the time the transistor operates in the active region is compared with a reference time and the error signal amplified to advance or delay the conduction in the next cycle. To limit the power dissipation the desaturation time is typically fixed to 10% of the period T.

At very low frequencies the ON threshold is fixed at 200mV of the input signal and the desaturation time is mainly determined by the peak waveform. This positive threshold also prevents permanent conduction when the motor is stopped. When the input frequency increases the dwell control gradually sets the desaturation time to 10% of the period. At higher frequencies the ON threshold becomes negative to permit a conduction angle of more than 50% always keeping desaturation time to 10% of the period.

CURRENT LIMITING

The current in the coil is measured by means of a voltage drop across a suitable resistor in the emitter lead of the power transistor. When the threshold voltage (260mV typ) is reached, the coil current is kept constant via a feedback loop.

DARLINGTON OVERVOLTAGE LIMITATION

The darlington is protected against overvoltage by means of an external divider R_5/R_6 (pin 15) and an internal zener. This zener drives the external darlington in order to limit the collector voltage.

CHARGING ANGLE SIGNAL OUTPUT

This signal is intended for tachometer applications (pin 5). It consists of an open collector stage with current internally limited at 10mA

"POWER ON" SIGNAL INPUT

In the low status this input forces the external darlington into conduction (pin 9). This control input can be used together with the conduction time information coming from pin 5 to bypass the normal dwell time calculation. When an external logic control is used to recognize particular engine condition (as in anti Knock system).

PROTECTION CIRCUITS

PERMANENT CONDUCTION PROTECTION

This function is intended to prevent continuous current conduction in the final stage when the magnetic pickup is open or intermittent. The duration of the intervention is set by means of a capacitor 1 at pin 3. Grounding pins 3 or 4, this protection is eliminated. The inhibit function at pin 4 is particularly useful when an external logic control is used to disable the permanent conduction protection.

dump is fixed by means of an external divider connected to pin 11.

OTHER APPLICATION INFORMATION

If the supply is voltage disconnected - or the battery wire is broken - while the current is flowing through the coil, the external diode D_1 keeps the coil current from recirculating into the device : in this way both device and darlington are protected.

REVERSE BATTERY AND DUMP PROTECTION

Due to the external resistors R_6, R_7, R_8, R_{10} the device is protected against reverse battery. The load dump protection withstands up to 100V with a decay time $\leq 300ms$. The intervention threshold for load

The zener diode D_z , connected between pin 14 and GND, allows to withstand positive spikes up to 200V.

The device - used in the recommended application circuit - satisfies the ISO/DP 7637/1 overvoltage standard.

Figure 1 : Typical Magnetic Pick-up Waveform and L484 Response at low and high frequency.

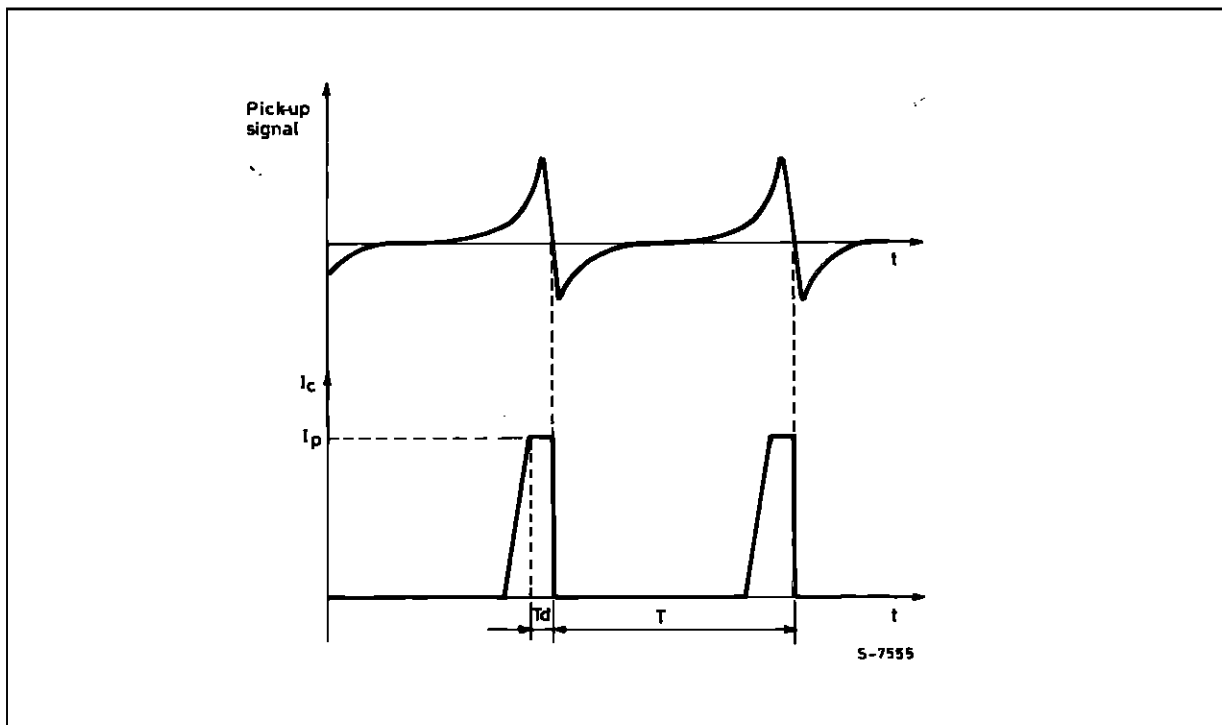

Figure 1 : Typical Magnetic Pick-up Waveform and L484 Response at Low and High Frequency (continued).

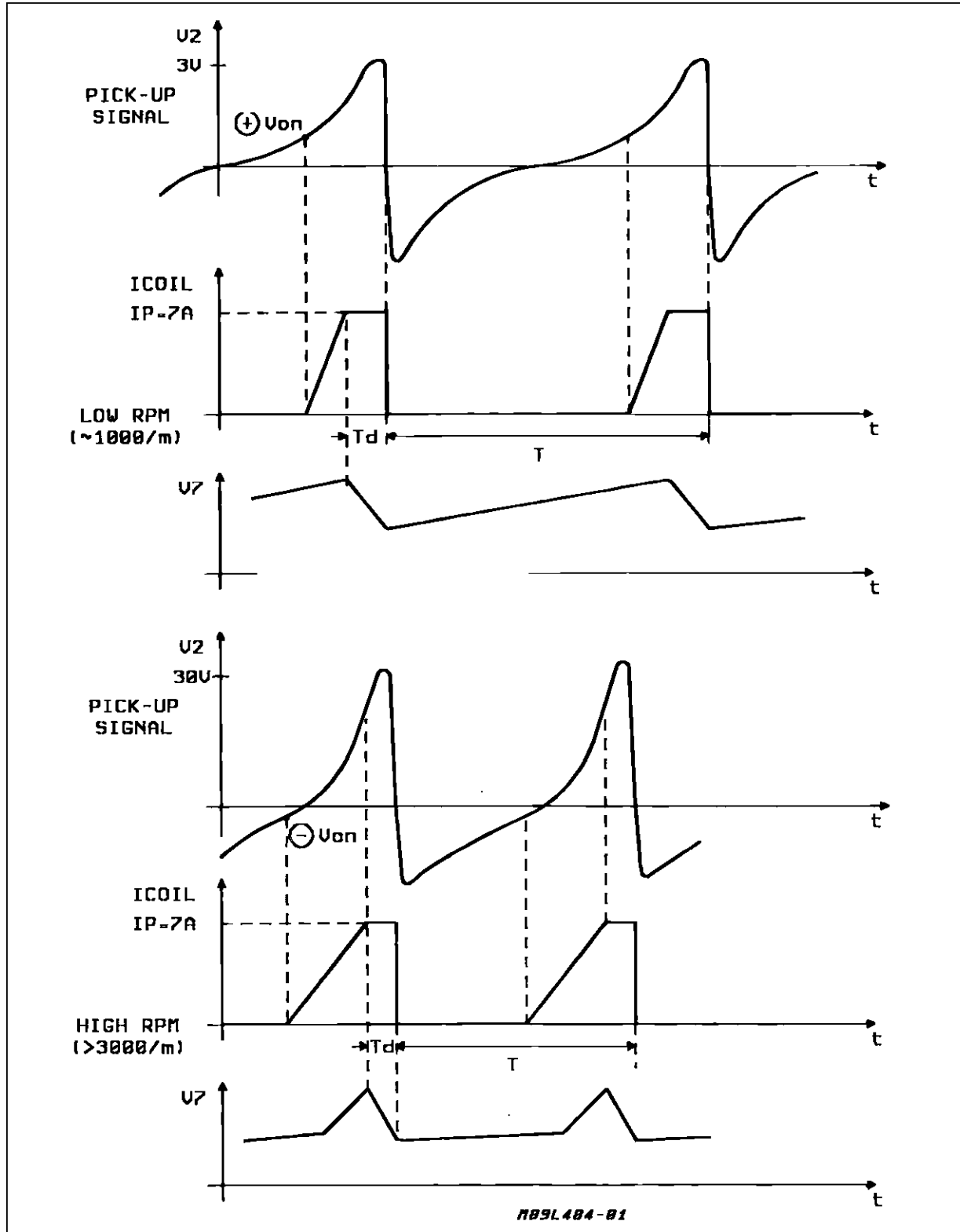
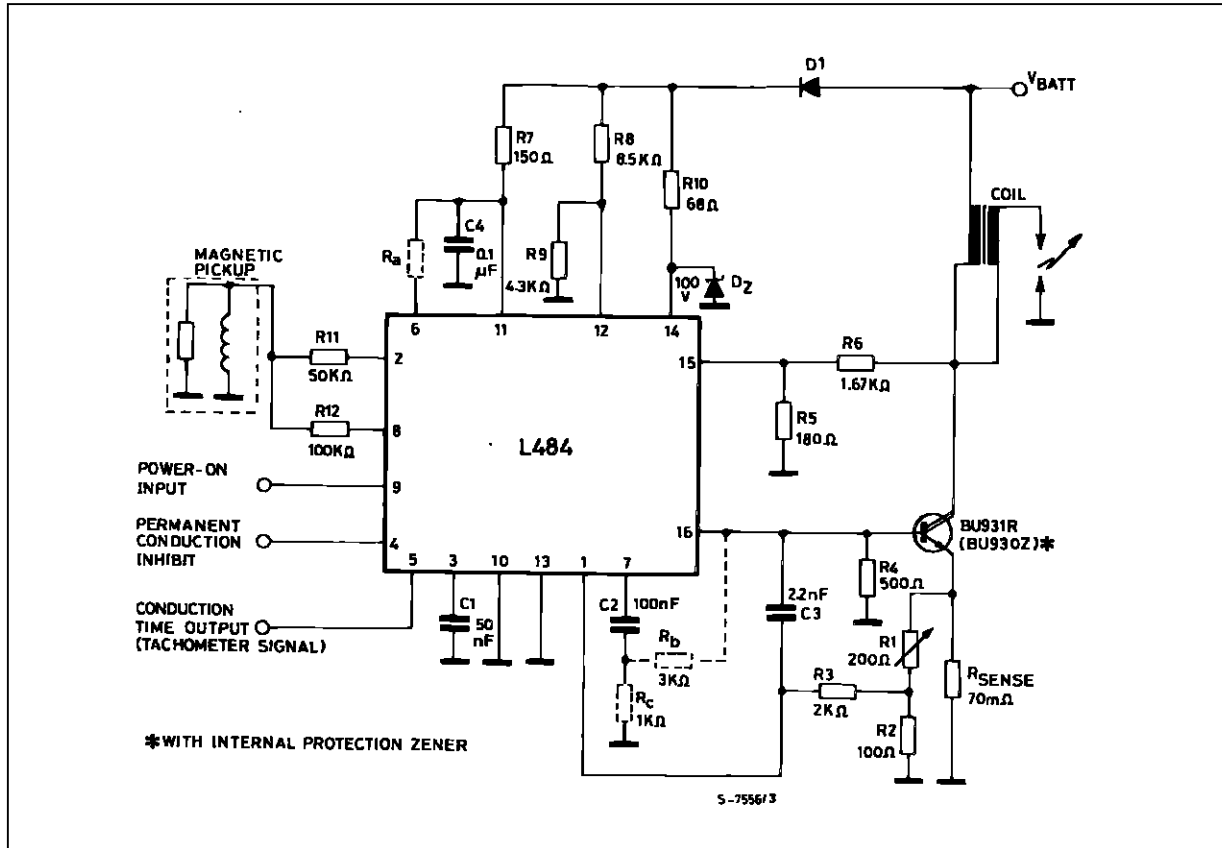
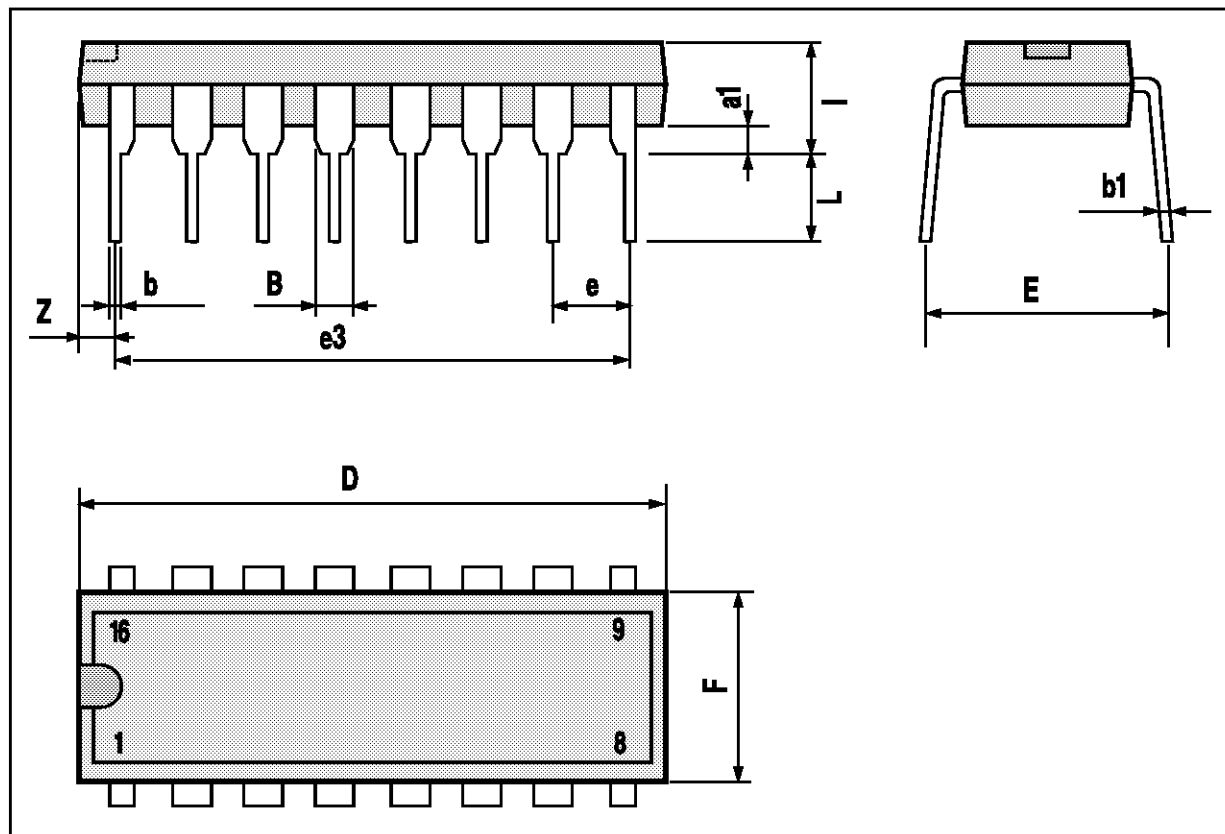

Figure 2 : Application Circuit.



DIP16 PACKAGE MECHANICAL DATA

DIM.	mm			inch		
	MIN.	TYP.	MAX.	MIN.	TYP.	MAX.
a1	0.51			0.020		
B	0.77		1.65	0.030		0.065
b		0.5			0.020	
b1		0.25			0.010	
D			20			0.787
E		8.5			0.335	
e		2.54			0.100	
e3		17.78			0.700	
F			7.1			0.280
I			5.1			0.201
L		3.3			0.130	
Z			1.27			0.050



SO16 PACKAGE MECHANICAL DATA

DIM.	mm			inch		
	MIN.	TYP.	MAX.	MIN.	TYP.	MAX.
A			1.75			0.069
a1	0.1		0.2	0.004		0.008
a2			1.6			0.063
b	0.35		0.46	0.014		0.018
b1	0.19		0.25	0.007		0.010
C		0.5			0.020	
c1	45° (typ.)					
D	9.8		10	0.386		0.394
E	5.8		6.2	0.228		0.244
e		1.27			0.050	
e3		8.89			0.350	
F	3.8		4.0	0.150		0.157
L	0.5		1.27	0.020		0.050
M			0.62			0.024
S	8° (max.)					

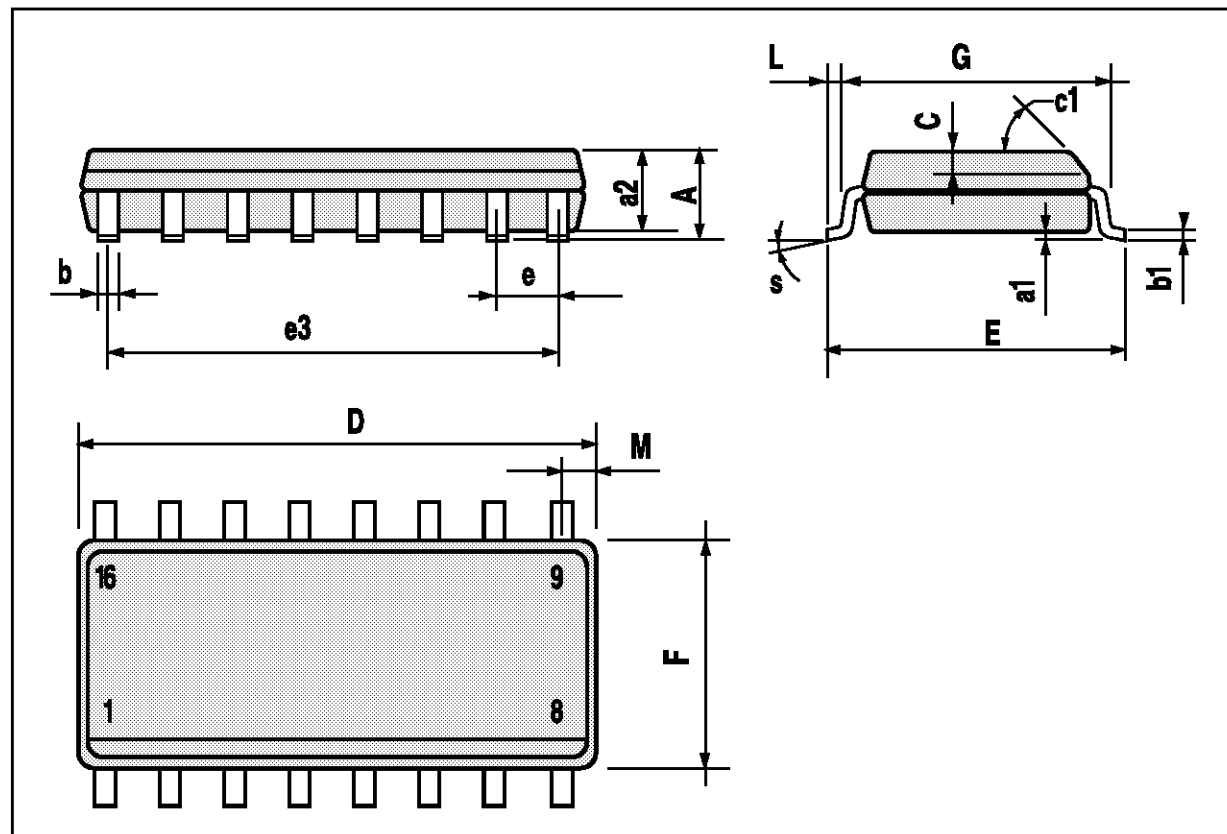

Information furnished is believed to be accurate and reliable. However, SGS-THOMSON Microelectronics assumes no responsibility for the consequences of use of such information nor for any infringement of patents or other rights of third parties which may result from its use. No license is granted by implication or otherwise under any patent or patent rights of SGS-THOMSON Microelectronics. Specifications mentioned in this publication are subject to change without notice. This publication supersedes and replaces all information previously supplied. SGS-THOMSON Microelectronics products are not authorized for use as critical components in life support devices or systems without express written approval of SGS-THOMSON Microelectronics.

© 1994 SGS-THOMSON Microelectronics - All Rights Reserved

SGS-THOMSON Microelectronics GROUP OF COMPANIES

Australia - Brazil - France - Germany - Hong Kong - Italy - Japan - Korea - Malaysia - Malta - Morocco - The Netherlands - Singapore - Spain - Sweden - Switzerland - Taiwan - Thailand - United Kingdom - U.S.A.