

RGB Video Amplifier for Monitors Monolithic IC MM1203

Outline

This IC is a wideband video amplifier system developed for high resolution RGB color monitors. In addition to the three matched video amps, it has three gate control differential input black level comparators for luminance adjustment, and three matched attenuator circuits for contrast adjustment. Each video amp has maximum gain setting ($AV=4\sim 10$) and a drive pin for trimming. The reference voltage supply for video input is built in.

Features

1. Three built-in wideband video amps (70MHz @ -3dB)
2. Current consumption 65mA typ.
3. Matched ($\pm 0.5\text{dB}$) contrast adjustment attenuators built in
4. Built-in luminance adjustment comparators using external gate control
5. Gain of each video amp controlled independently
6. Built-in video input reference voltage
7. Low impedance output driver

Package

DIP-28B (MM1203ND)

Applications

1. Display monitors

Block Diagram

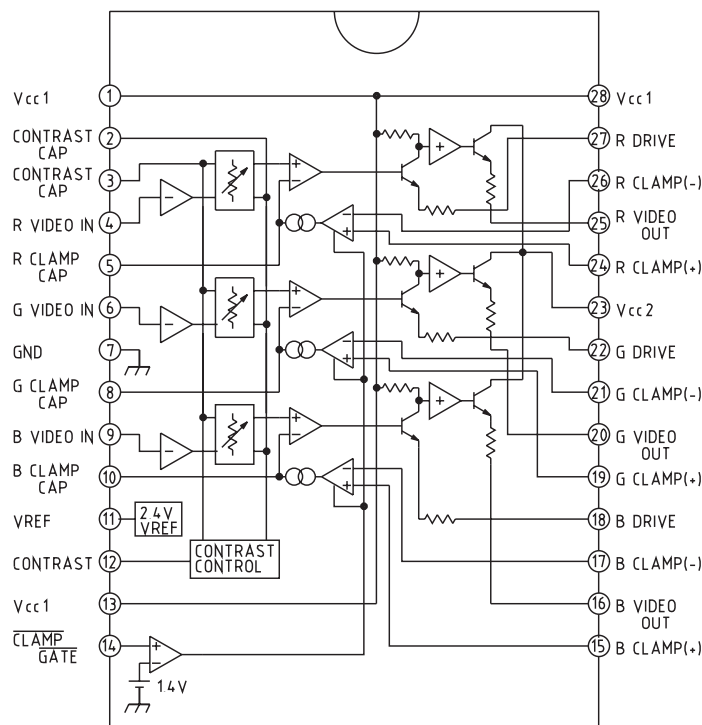

Pin Description

Pin no.	Pin name	Function	Pin no.	Pin name	Function
1	Vcc1	Vcc1	15	B CLAMP (+)	B clamp input (+)
2	CONTRAST CAP	Contrast capacitor	16	B VIDEO OUT	B video output
3	CONTRAST CAP	Contrast capacitor	17	B CRAMP (-)	B clamp input (-)
4	R VIDEO IN	R video input	18	B DRIVE	B drive
5	R CLAMP CAP	R clamp capacitor	19	G CLAMP (+)	G clamp input (+)
6	G VIDEO IN	G video input	20	G VIDEO OUT	G video output
7	GND	GND	21	G CLMP (-)	G clamp input (-)
8	G CALMP CAP	G clamp capacitor	22	G DRIVE	G drive
9	B VIDEO IN	B video input	23	Vcc2	Vcc2
10	B CLAMP CAP	B clamp capacitor	24	R CLAMP (+)	R clamp input (+)
11	VREF	Video input reference voltage	25	R VIDEO OUT	R video output
12	CONTRAST	Contrast control	26	R CLAMP (-)	R clamp input (-)
13	Vcc1	Vcc1	27	R DRIVE	R drive
14	CLAMP GATE	Clamp gate input	28	Vcc1	Vcc1

Absolute Maximum Ratings (Ta=25°C)

Item	Symbol	Ratings	Units
Storage temperature	T _{STG}	-55~+150	°C
Operating temperature	T _{OPR}	-0~+70	°C
Power supply voltage	V _{CC}	13.5	V
Pin input voltage	V _{IN}	GND ≤ V _{IN} ≤ V _{CC}	V
Video output current	I _o	28	mA
Allowable loss	P _d	2.5	W
Electrostatic breakdown *9		2	kV
Pin temperature *10		265	°C

Recommended Operating Conditions (Ta=°C)

Item	Symbol	Conditions	Min.	Typ.	Max.	Units
Operating power supply voltage	V _{CC}		10.8	12.0	13.2	V

DC Electrical Characteristics (Except where noted otherwise, Ta=25°C, Vcc1=Vcc2=12V, V12=6V, V14=0V, V15=2V, S1, 2, 3=OFF)

Item	Symbol	Measurement conditions	Min.	Typ.	Max.	Units
Consumption current	Icc1	only Vcc1		65	85	mA
Video input reference voltage	VREF		2.2	2.4	2.6	V
Video input bias current	IB			5.0	20	μA
Clamp gate input voltage L	VcGL		0.8	1.2		V
Clamp gate input voltage H	VcGH			1.6	2.0	V
Clamp gate input current L	IcGL	V14=0V		-0.5	-0.5	μA
Clamp gate input current H	IcGH	V14=12V		0.005	1.0	μA
Clamping capacitor charge current	IcL+	V5, 8, 10=0V	500	850		μA
Clamping capacitor discharge current	IcL-	V5, 8, 10=5V	-500	-850		μA
Video output voltage L	VOL	V5, 8, 10=0V		0.9	1.25	V
Video output voltage H	VOH	V5, 8, 10=5V	8.2	8.9		V
Video output offset difference 1	ΔVof1	V15=2V *2		±0.5	±50	mV
Video output offset difference 2	ΔVof2	V15=4V *2		±0.5	±50	mV

AC Electrical Characteristics (Except where noted otherwise, Ta=25°C, Vcc1=Vcc2=12V, V12=12V, V14=0V, V15=4V, fin=10kHz, S1, 2, 3=ON)

Item	Symbol	Measurement conditions	Min.	Typ.	Max.	Units
Video amp gain	Av	VIN=560mVp-p	4.5	6.0		V/V
Gain attenuation 1	ΔAv1	V12=5V, VIN=560mVp-p	-12.5	-10	-7.5	dB
Gain attenuation 2	ΔAv2	V12=2V, VIN=560mVp-p		-40		dB
Gain matching	AVMAT	*3		0.5	1.0	dB
Gain fluctuation matching 1	ΔAVM1	V12=5V *3 *4		0.1	0.5	dB
Gain fluctuation matching 2	ΔAVM2	V12=V12LOW *3 *5		0.3		dB
Video amp distortion	THD	V12=3V, VOUT=1Vp-p		0.5		%
Video amp frequency bandwidth	fbw	VIN=100mVrms *6 *7	70	120		MHz
Output rise time	tr	VOUT=4Vp-p *6		5		μS
Output fall time	tf	VOUT=4Vp-p *6		7		μS
Crosstalk 1	VSEP1	f=10kHz, VIN=1Vp-p *8		-65		dB
Crosstalk 2	VSEP2	f=10kHz, VIN=1Vp-p *6 *8		-46		dB

Notes:

- *1 Vcc power supply pins 1, 13, 23 and 28 are connected to each other externally.
- *2 Measure offset voltage between any two amps.
- *3 Measure gain difference between any two amps. VIN=1Vp-p
- *4 Measure attenuation amount relative to Av max., and quantify the difference between any two amps.
- *5 The voltage at which V12 low is -40dB relative to AV max. for attenuation.
- *6 Mount on printed board with ground shield on both sides.
- *7 -3dB cutoff frequency from video amp gain.
- *8 Input a signal to any amp and terminate input for the remaining two amps (use resistor that corresponds to signal source load), then measure output.
- *9 Human model. Discharge via 1.5kΩ from 100pF capacitor.
- *10 Solder for 10 seconds.

Measuring Circuit

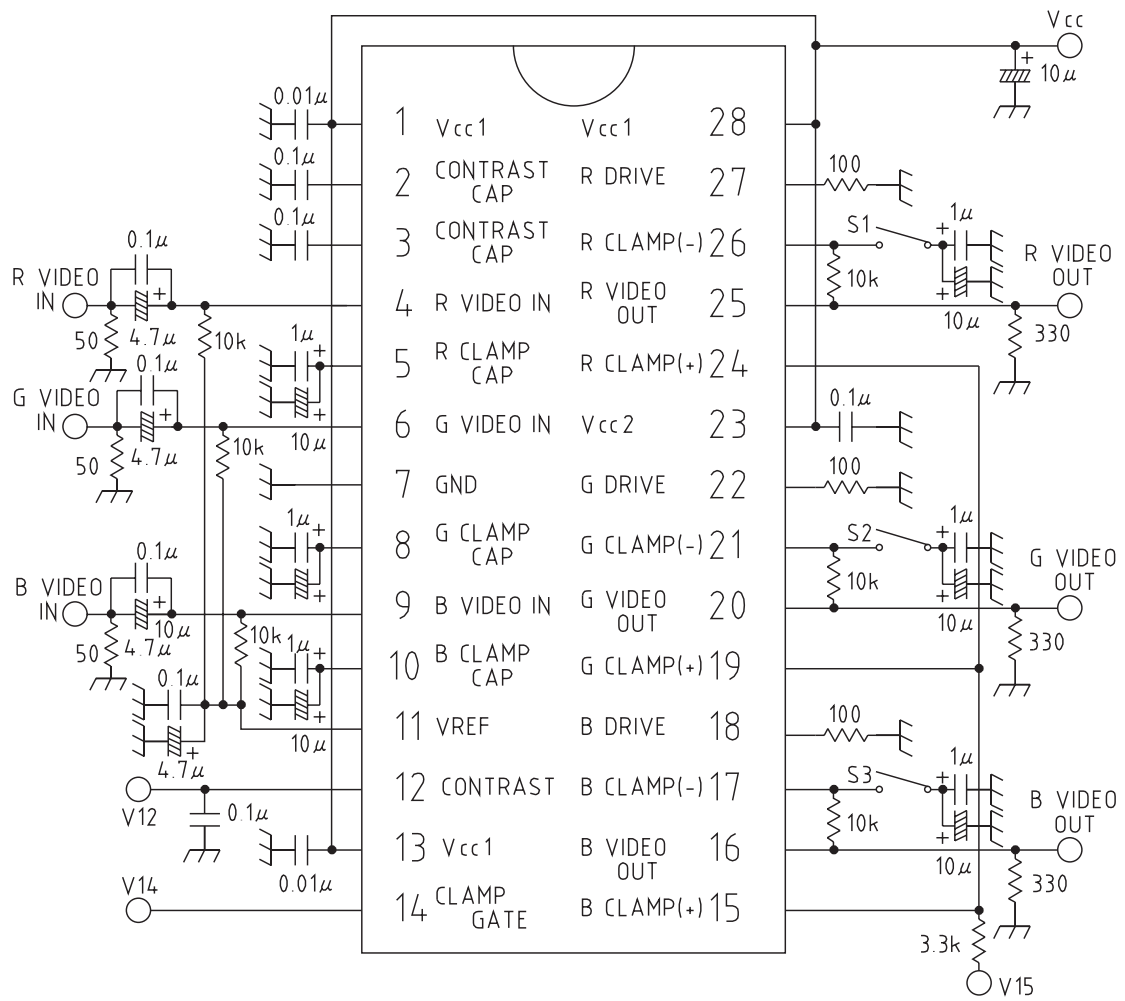

Measuring Circuit

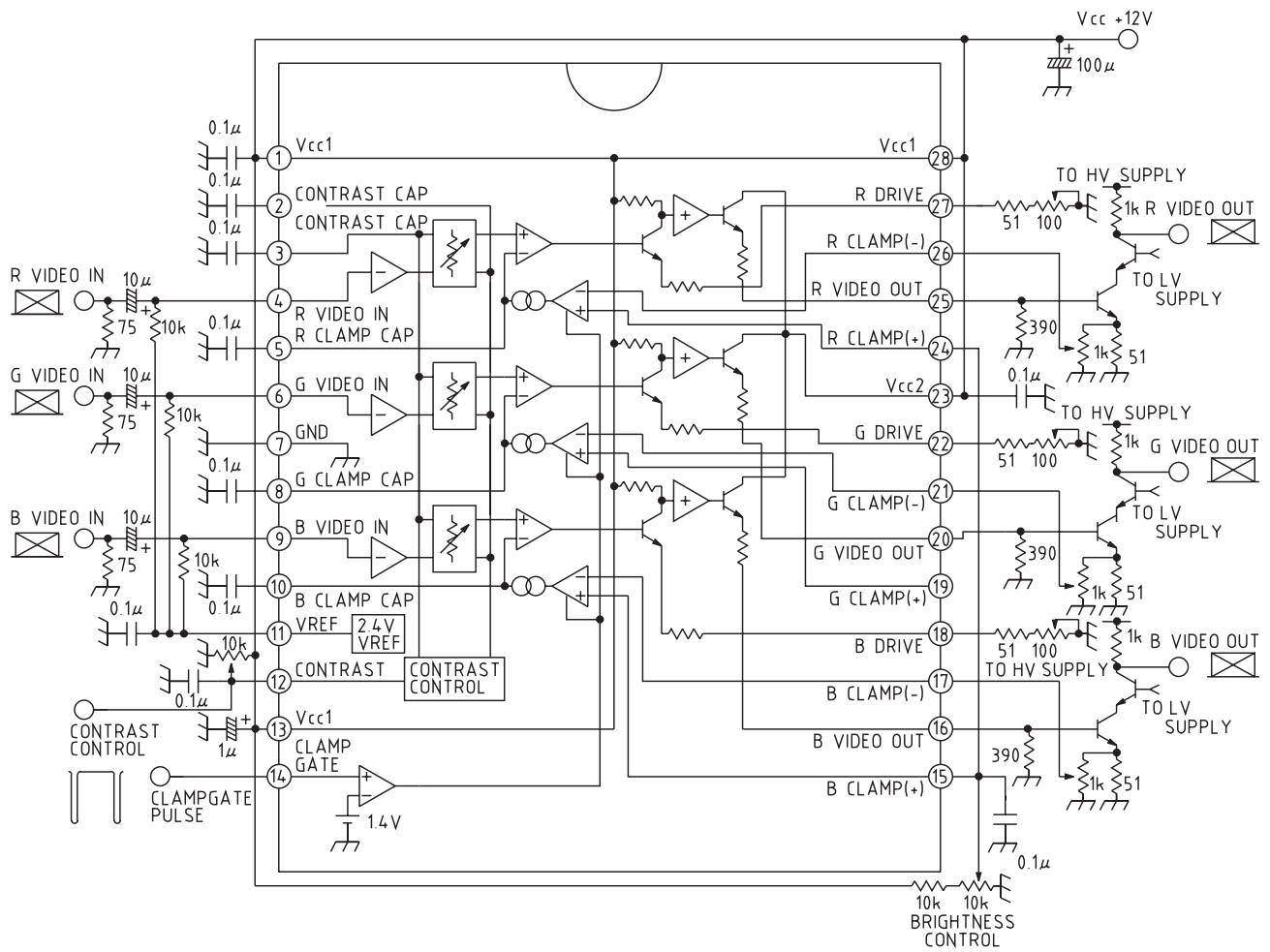

Characteristics

Gain-Frequency

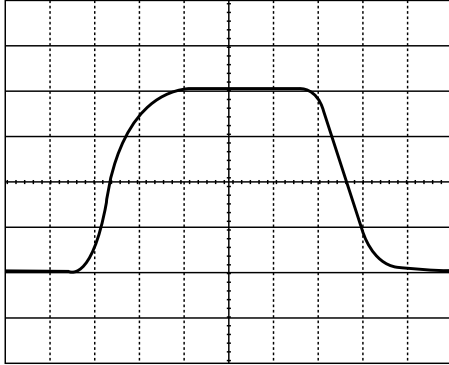

Gain - Frequency
($V_{OUT}=4V_{P-P}$)

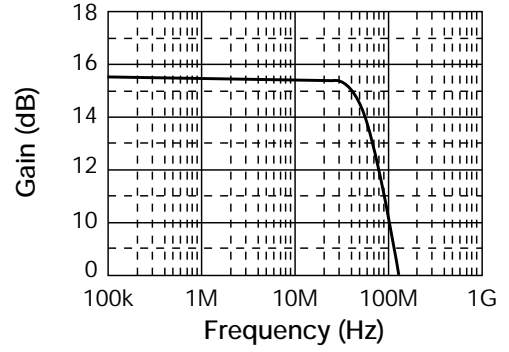

Attenuation-Contrast Voltage

Attenuation - Contrast Voltage

