

2609C Broadband Photodiode Module

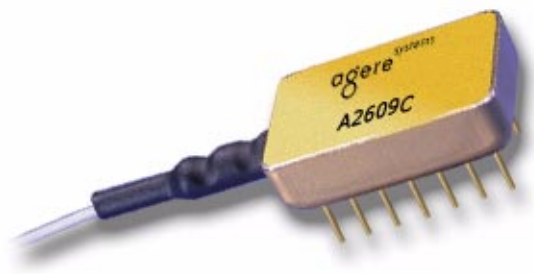

Features

- 1 GHz flat response, ± 0.5 dB
- High responsivity:
 - >0.85 A/W at 1310 nm
 - 0.95 A/W at 1550 nm
- Internal current gain, 6 dB (typ.)
- 75Ω impedance-matched

Applications

- Extended bandwidth, broadband CATV receivers

Description

The 2609C is a packaged impedance-matched photodiode module with internal gain designed for use in optical broadband receivers in fiber-optic networks. The patented impedance-match technology results in improved gain-bandwidth product compared to external circuits due to control of parasitics between the photodiode and the impedance-matching circuit.

Pin Information

Table 1. Pin Descriptions

Pin No.	Description
1	Ground
2	Ground
3	Ground
4	Ground
5	Ground
6	Ground
7	Open
8	Open
9	RF Out
10	Ground
11	Bias
12	Ground
13	Open
14	Ground

Absolute Maximum Ratings

Stresses in excess of the absolute maximum ratings can cause permanent damage to the device. These are absolute stress ratings only. Functional operation of the device is not implied at these or any other conditions in excess of those given in the operational sections of the data sheet. Exposure to absolute maximum ratings for extended periods can adversely affect device reliability.

Parameter	Symbol	Min	Max	Unit
Operating Case Temperature Range	T _C	-40	85	°C
Storage Temperature Range	T _{stg}	-40	85	°C
Optical Input Power	P _{IN}	—	2	mW
dc Bias Voltage	V _{PD}	—	25	V
Forward Current	I _F	—	10	mA

Characteristics.

Table 2. Electrical/Optical Characteristics

Parameter	Symbol	Min	Typ	Max	Unit
Optical Wavelength Range	λ	1310—1550 \pm 20	—	—	nm
Responsivity	—	—	>0.85 at 1310 nm, >0.95 at 1550 nm	—	mA/mW mA/mW
Optical Return Loss ¹	RL	—	>45	—	dB
Bias Voltage	—	—	15 (nominal)	—	V
Dark Current	I _D	—	200 at 20 °C	—	nA

1. Without connector

Table 3. RF Characteristics

Parameter	Symbol	Min	Typ	Max	Unit
Frequency Range	F	40	—	1000	MHz
Gain ¹	G	—	>5	—	dB
Frequency Response	—	—	< \pm 0.5	—	dB
Receiver Noise	—	See Figure 1.			—
Distortion Products ² :					
Second Order	CSO	—	<-70	—	dBc
Third Order	CTB	—	<-80	—	dBc

1. Current gain of internal transformer circuit.

2. Two laser test. Each laser has 40% modulation index. Total received optical power is 0 dBm. Distortion products measured at 80 MHz, 450 MHz, 600 MHz, 850 MHz, and 1000 MHz.

Characteristics Curves

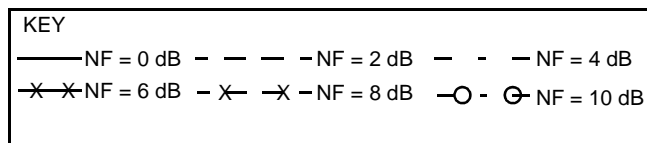
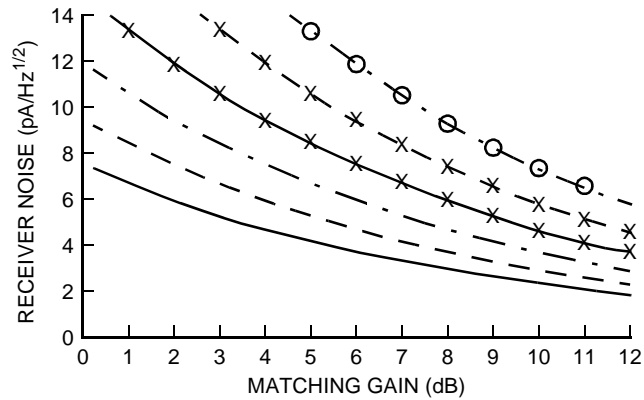

1-1182 (F).b

Figure 1. Receiver Noise

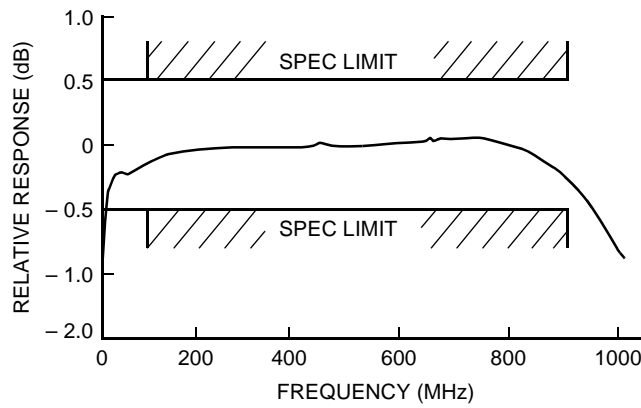

1-1184 (F).b

Figure 2. Typical Frequency Response Measured into 75 Ω Load, VSWR <1.5

Outline Diagram

Dimensions are in inches and (millimeters).

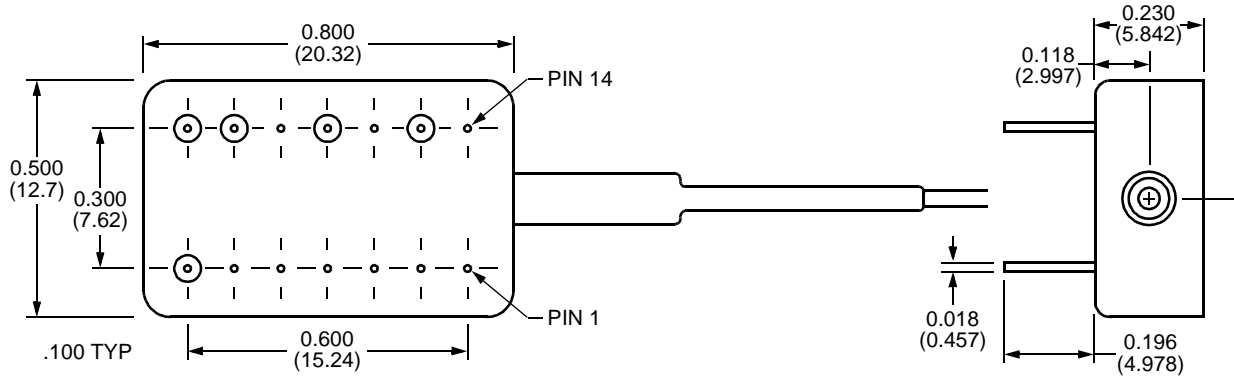

1-1183 (F).b

Ordering Information

Table 4. Ordering Information*

Device Code	Description	Connector	Pigtail	Comcode
2609C	Broadband Photodiode Module	None	Single mode, 9 μm /125 μm	108867425

* Other options available. For additional ordering information, please contact an account manager at OPTO West, Agere Systems Inc., 1-800-362-3891 (for sales staff, please press option 2).

For additional information, contact your Agere Systems Account Manager or the following:

INTERNET: <http://www.agere.com>

E-MAIL: docmaster@micro.lucent.com

N. AMERICA: Agere Systems Inc., 555 Union Boulevard, Room 30L-15P-BA, Allentown, PA 18109-3286
1-800-372-2447, FAX 610-712-4106 (In CANADA: 1-800-553-2448, FAX 610-712-4106)

ASIA PACIFIC: Agere Systems Singapore Pte. Ltd., 77 Science Park Drive, #03-18 Cintech III, Singapore 118256
Tel. (65) 778 8833, FAX (65) 777 7495

CHINA: Agere Systems (Shanghai) Co., Ltd., 33/F Jin Mao Tower, 88 Century Boulevard Pudong, Shanghai 200121 PRC
Tel. (86) 21 50471212, FAX (86) 21 50472266

JAPAN: Agere Systems Japan Ltd., 7-18, Higashi-Gotanda 2-chome, Shinagawa-ku, Tokyo 141, Japan
Tel. (81) 3 5421 1600, FAX (81) 3 5421 1700

EUROPE: Data Requests: DATALINE: Tel. (44) 7000 582 368, FAX (44) 1189 328 148
Technical Inquiries: OPTOELECTRONICS MARKETING: (44) 1344 865 900 (Ascot UK)

Agere Systems Inc. reserves the right to make changes to the product(s) or information contained herein without notice. No liability is assumed as a result of their use or application.