

Full Duplex RS-485 Transceivers

- +5V Only
- Low Power BiCMOS
- Driver/Receiver Enable (**SP491**)
- RS-485 and RS-422 Drivers/Receivers
- Pin Compatible with LTC490 and SN75179 (**SP490**)
- Pin Compatible with LTC491 and SN75180 (**SP491**)



DESCRIPTION

The **SP490** is a low power differential line driver/receiver meeting RS-485 and RS-422 standards up to 5Mbps. The **SP491** is identical to the **SP490** with the addition of driver and receiver tri-state enable lines. Both products feature $\pm 200\text{mV}$ receiver input sensitivity, over wide common mode range. The **SP490** is available in 8-pin plastic DIP and 8-pin NSOIC packages for operation over the commercial and industrial temperature ranges. The **SP491** is available in 14-pin DIP and 14-pin NSOIC packages for operation over the commercial and industrial temperature ranges.

BLOCK DIAGRAMS

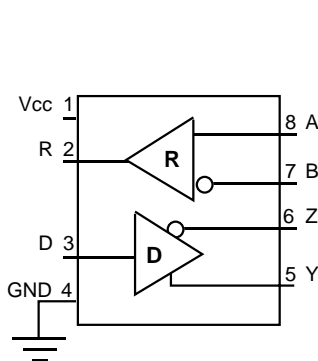

SP490

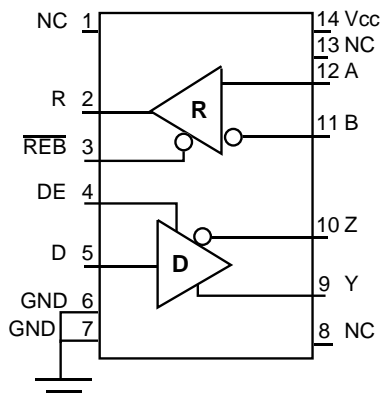

SP491

ABSOLUTE MAXIMUM RATINGS

These are stress ratings only and functional operation of the device at these ratings or any other above those indicated in the operation sections of the specifications below is not implied. Exposure to absolute maximum rating conditions for extended periods of time may affect reliability.

V _{CC}	+7V
Input Voltages	
Drivers.....	-0.5V to (V _{CC} +0.5V)
Receivers.....	±14V
Output Voltages	
Drivers.....	±14V
Receivers.....	-0.5V to (V _{CC} +0.5V)
Storage Temperature.....	-65° C to +150°
Power Dissipation.....	1000mW

ELECTRICAL CHARACTERISTICS

T_{MIN} to T_{MAX} and V_{CC} = 5V ± 5% unless otherwise noted.

PARAMETERS	MIN.	TYP.	MAX.	UNITS	CONDITIONS
SP490 DRIVER					
DC Characteristics					
Differential Output Voltage	GND		V _{CC}	Volts	Unloaded; R = ∞ ; <i>see figure 1</i>
Differential Output Voltage	2		V _{CC}	Volts	With Load; R = 50Ω; (RS422); <i>see figure 1</i>
Differential Output Voltage Change in Magnitude of Driver	1.5		V _{CC}	Volts	With Load; R = 27Ω; (RS485); <i>see figure 1</i>
Differential Output Voltage for Complimentary States			0.2	Volts	R = 27Ω or R = 50Ω; <i>see figure 1</i>
Driver Common-Mode Output Voltage			3	Volts	R = 27Ω or R = 50Ω; <i>see figure 1</i>
Input High Voltage	2.0			Volts	Applies to D
Input Low Voltage			0.8	Volts	Applies to D
Input Current			±10	μA	Applies to D
Driver Short-Circuit Current					
V _{OUT} = HIGH	35		250	mA	-7V ≤ V _O ≤ +12V
V _{OUT} = LOW	35		250	mA	-7V ≤ V _O ≤ +12V
SP490 DRIVER					
AC Characteristics					
Maximum Data Rate	5			Mbps	
Driver Input to Output		30	60	ns	t _{PLH} ; R _{DIFF} = 54Ω, C _{L1} = C _{L2} = 100pF; <i>see figures 3 and 6</i>
Driver Input to Output		30	60	ns	t _{PHL} ; R _{DIFF} = 54Ω, C _{L1} = C _{L2} = 100pF; <i>see figures 3 and 6</i>
Driver Skew		5		ns	<i>see figures 3 and 6</i> , t _{SKREW} = t _{DPLH} - t _{DPHL}
Driver Rise or Fall Time		15	40	ns	From 10% to 90%; R _{DIFF} = 54Ω, C _{L1} = C _{L2} = 100pF; <i>see figures 3 and 6</i>
SP490 RECEIVER					
DC Characteristics					
Differential Input Threshold	0.2		+0.2	Volts	-7V ≤ V _{CM} ≤ 12V
Input Hysteresis		70		mV	V _{CM} = 0V
Output Voltage High	3.5			Volts	I _O = -4mA, V _{ID} = +200mV
Output Voltage Low			0.4	Volts	I _O = +4mA, V _{ID} = -200mV
Input Resistance	12	15		kΩ	-7V ≤ V _{CM} ≤ 12V
Input Current (A, B); V _{IN} = 12V			±1.0	mA	V _{IN} = 12V
Input Current (A, B); V _{IN} = -7V			-0.8	mA	V _{IN} = -7V
Short-Circuit Current			85	mA	0V ≤ V _O ≤ V _{CC}

ELECTRICAL CHARACTERISTICS

T_{MIN} to T_{MAX} and $V_{CC} = 5V \pm 5\%$ unless otherwise noted.

PARAMETERS	MIN.	TYP.	MAX.	UNITS	CONDITIONS
SP490 RECEIVER					
AC Characteristics					
Maximum Data Rate	5	90	150	Mbps	$t_{PLH}; R_{DIFF} = 54\Omega,$ $C_{L1} = C_{L2} = 100pF;$ <i>Figures 3 & 8</i> $t_{PHL}; R_{DIFF} = 54\Omega,$ $C_{L1} = C_{L2} = 100pF;$ <i>Figures 3 & 8</i> $R_{DIFF} = 54\Omega; C_{L1} = C_{L2} = 100pF;$ <i>Figures 3 & 8</i>
Receiver Input to Output		90	150	ns	
Diff. Receiver Skew $ t_{PLH} - t_{PHL} $		13		ns	
POWER REQUIREMENTS					
Supply Voltage	+4.75		+5.25	Volts	
Supply Current		900		μA	
ENVIRONMENTAL AND MECHANICAL					
Operating Temperature					
Commercial (_C_)	0		+70	$^{\circ}C$	
Industrial (_E_)	-40		+85	$^{\circ}C$	
Storage Temperature	-65		+150	$^{\circ}C$	
Package					
Plastic DIP (_S_)					
NSOIC (_N)					

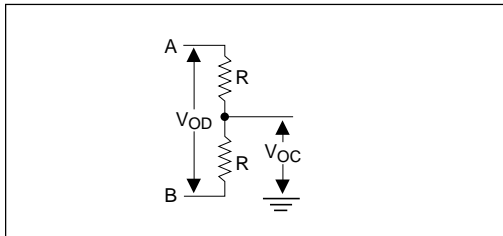

Figure 1. Driver DC Test Load Circuit

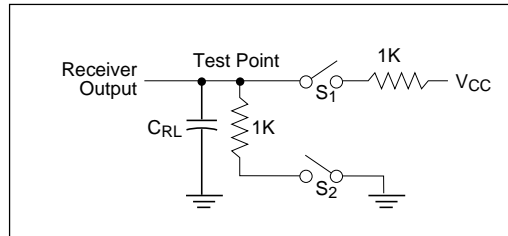

Figure 2. Receiver Timing Test Load Circuit

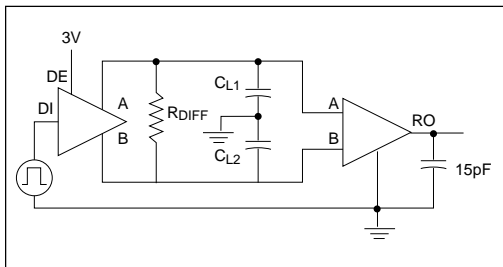

Figure 3. Driver/Receiver Timing Test Circuit

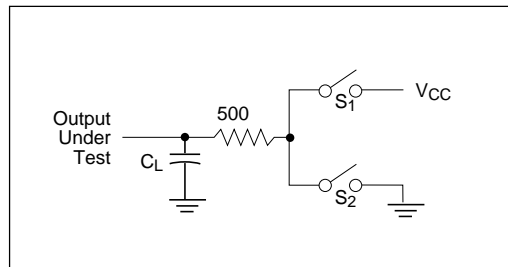

Figure 4. Driver Timing Test Load #2 Circuit

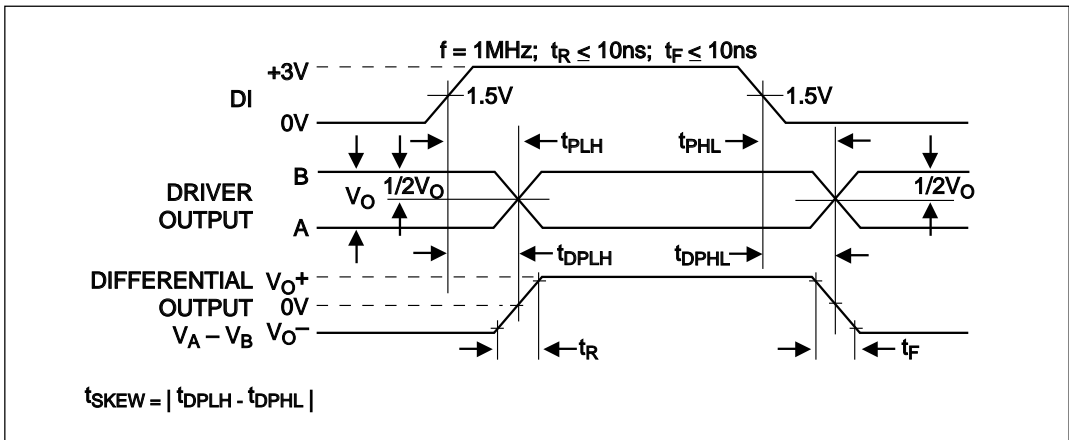

Figure 6. Driver Propagation Delays

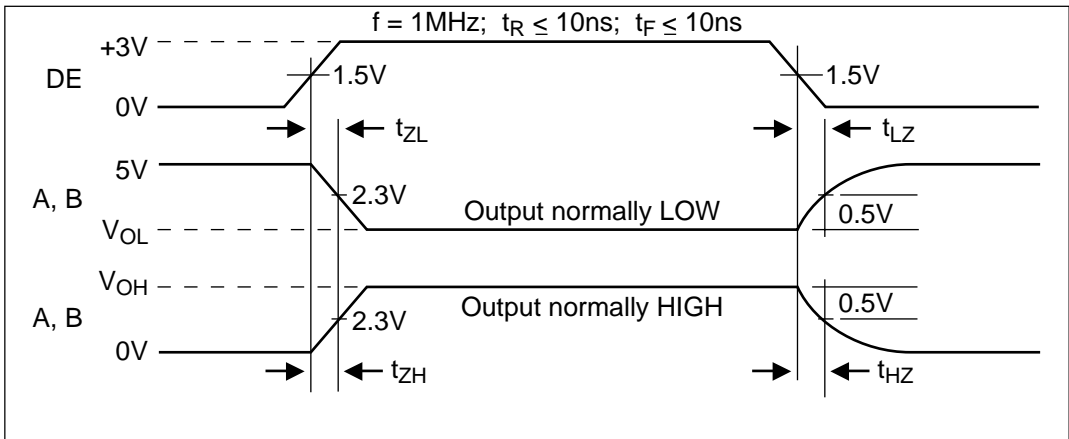

Figure 7. Driver Enable and Disable Times

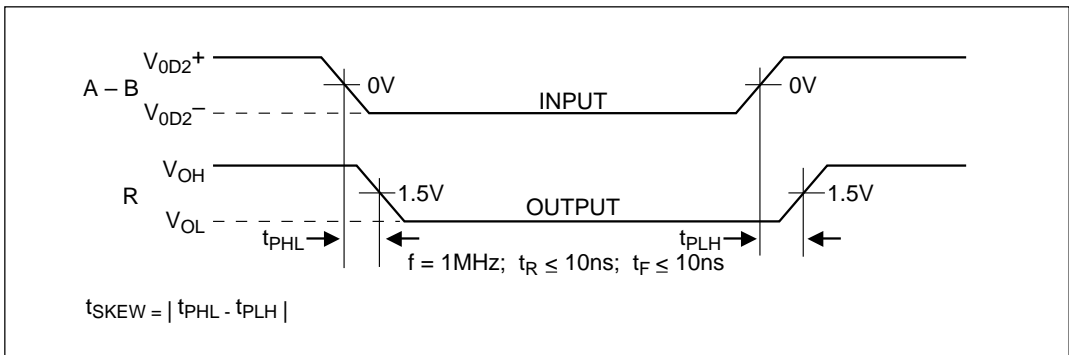

Figure 8. Receiver Propagation Delays

ABSOLUTE MAXIMUM RATINGS

These are stress ratings only and functional operation of the device at these ratings or any other above those indicated in the operation sections of the specifications below is not implied. Exposure to absolute maximum rating conditions for extended periods of time may affect reliability.

V _{CC}	+7V
Input Voltages	
Logic.....	-0.5V to (V _{CC} +0.5V)
Drivers.....	-0.5V to (V _{CC} +0.5V)
Receivers.....	±14V
Output Voltages	
Logic.....	-0.5V to (V _{CC} +0.5V)
Drivers.....	±14V
Receivers.....	-0.5V to (V _{CC} +0.5V)
Storage Temperature.....	-65°C to +150
Power Dissipation.....	1000mW

ELECTRICAL CHARACTERISTICS

T_{MIN} to T_{MAX} and V_{CC} = 5V ± 5% unless otherwise noted.

PARAMETERS	MIN.	TYP.	MAX.	UNITS	CONDITIONS
SP491 DRIVER					
DC Characteristics					
Differential Output Voltage	GND		V _{CC}	Volts	Unloaded; R = ∞ ; see figure 1
Differential Output Voltage	2		V _{CC}	Volts	With Load; R = 50Ω; (RS422); see figure 1
Differential Output Voltage	1.5		V _{CC}	Volts	With Load; R = 27Ω; (RS485); see figure 1
Change in Magnitude of Driver Differential Output Voltage for Complimentary States			0.2	Volts	R = 27Ω or R = 50Ω; see figure 1
Driver Common-Mode Output Voltage			3	Volts	R = 27Ω or R = 50Ω; see figure 1
Input High Voltage	2.0			Volts	Applies to D, REB, DE
Input Low Voltage			0.8	Volts	Applies to D, REB, DE
Input Current			±10	μA	Applies to D, REB, DE
Driver Short-Circuit Current					
V _{OUT} = HIGH	35		250	mA	-7V ≤ V _O ≤ 12V
V _{OUT} = LOW	35		250	mA	-7V ≤ V _O ≤ 12V
SP491 DRIVER					
AC Characteristics					
Maximum Data Rate	5			Mbps	REB = 5V, DE = 5V
Driver Input to Output	20	30	60	ns	t _{PLH} ; R _{DIFF} = 54Ω, C _{L1} = C _{L2} = 100pF; see figures 3 and 6
Driver Input to Output	20	30	60	ns	t _{PHL} ; R _{DIFF} = 54Ω, C _{L1} = C _{L2} = 100pF; see figures 3 and 6
Driver Skew		5	10	ns	see figures 3 and 6,
Driver Rise or Fall Time	3	15	40	ns	t _{SKREW} = t _{DPLH} - t _{DPHL} From 10% to 90%; R _{DIFF} = 54Ω, C _{L1} = C _{L2} = 100pF; see figures 3 and 6
Driver Enable to Output High		40	70	ns	C _{L1} = C _{L2} = 100pF; see figures 4 and 7; S ₂ closed
Driver Enable to Output Low		40	70	ns	C _{L1} = C _{L2} = 100pF; see figures 4 and 7; S ₁ closed
Driver Disable Time from Low		40	70	ns	C _{L1} = C _{L2} = 100pF; see figures 4 and 7; S ₁ closed
Driver Disable Time from High		40	70	ns	C _{L1} = C _{L2} = 100pF; see figures 4 and 7; S ₂ closed

ELECTRICAL CHARACTERISTICS

T_{MIN} to T_{MAX} and $V_{CC} = 5V \pm 5\%$ unless otherwise noted.

PARAMETERS	MIN.	TYP.	MAX.	UNITS	CONDITIONS
SP491 RECEIVER					
DC Characteristics					
Differential Input Threshold	-0.2		+0.2	Volts	$-7V \leq V_{CM} \leq 12V$
Input Hysteresis		70		mV	$V_{CM} = 0V$
Output Voltage High	3.5			Volts	$I_O = -4mA, V_{ID} = +200mV$
Output Voltage Low			0.4	Volts	$I_O = +4mA, V_{ID} = -200mV$
Three State (high impedance)					
Output Current			± 1	μA	$0.4V \leq V_O \leq 2.4V; \overline{REB} = 5V$
Input Resistance	12	15		$k\Omega$	$-7V \leq V_{CM} \leq 12V$
Input Current (A, B); $V_{IN} = 12V$			± 1.0	mA	$DE = 0V, V_{CC} = 0V$ or $5.25V, V_{IN} = 12V$
Input Current (A, B); $V_{IN} = -7V$			-0.8	mA	$DE = 0V, V_{CC} = 0V$ or $5.25V, V_{IN} = -7V$
Short-Circuit Current	7		85	mA	$0V \leq V_O \leq V_{CC}$
SP491 RECEIVER					
DC Characteristics					
Maximum Data Rate	5			Mbps	$\overline{REB} = 0V$
Receiver Input to Output	60	90	150	ns	$t_{PLH}; R_{DIFF} = 54\Omega,$ $C_{L1} = C_{L2} = 100pF; Figures 3 \& 8$
Receiver Input to Output	60	90	150	ns	$t_{PHL}; R_{DIFF} = 54\Omega,$ $C_{L1} = C_{L2} = 100pF; Figures 3 \& 8$
Diff. Receiver Skew $t_{PLH} - t_{PHL}$		13		ns	$R_{DIFF} = 54\Omega; C_{L1} = C_{L2} = 100pF;$ <i>Figures 3 & 8</i>
Receiver Enable to Output Low		20	50	ns	$C_{RL} = 15pF; Figures 2 \text{ and } 9; S_1 \text{ closed}$
Receiver Enable to Output High		20	50	ns	$C_{RL} = 15pF; Figures 2 \text{ and } 9; S_2 \text{ closed}$
Receiver Disable from Low		20	50	ns	$C_{RL} = 15pF; Figures 2 \text{ and } 9; S_1 \text{ closed}$
Receiver Disable from High		20	50	ns	$C_{RL} = 15pF; Figures 2 \text{ and } 9; S_2 \text{ closed}$
POWER REQUIREMENTS					
Supply Voltage	+4.75		+5.25	Volts	
Supply Current		600		μA	$\overline{REB}, D = 0V$ or $V_{CC}; DE = V_{CC}$
SP491 ENVIRONMENTAL AND MECHANICAL					
Operating Temperature					
Commercial (<u>C</u>)	0		+70	$^{\circ}C$	
Industrial (<u>E</u>)	-40		+85	$^{\circ}C$	
Storage Temperature	-65		+150	$^{\circ}C$	
Package					
Plastic DIP (<u>S</u>)					
NSOIC (<u>N</u>)					

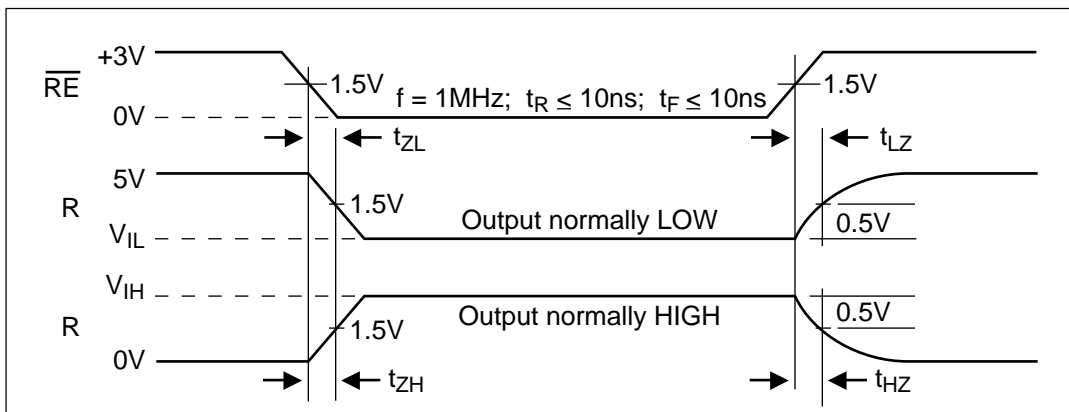

Figure 9. Receiver Enable and Disable Times

DESCRIPTION

The **SP490** and **SP491** are full-duplex differential transceivers that meet the requirements of RS-485 and RS-422. Fabricated with a **Sipex** proprietary BiCMOS process, both products require a fraction of the power of older bipolar designs.

The RS-485 standard is ideal for multi-drop applications or for long-distance interfaces. RS-485 allows up to 32 drivers and 32 receivers to be connected to a data bus, making it an ideal choice for multi-drop applications. Since the cabling can be as long as 4,000 feet, RS-485 transceivers are equipped with a wide (-7V to +12V) common mode range to accommodate ground potential differences. Because RS-485 is a differential interface, data is virtually immune to noise in the transmission line.

Driver...

The drivers for both the **SP490** and **SP491** have differential outputs. The typical voltage output swing with no load will be 0 volts to +5 volts. With worst case loading of 54Ω across the differential outputs, the driver can maintain greater than 1.5V voltage levels.

The driver of the **SP491** has a driver enable control line which is active high. A logic high on DE (pin 4) of the **SP491** will enable the differential driver outputs. A logic low on DE (pin 4) of the **SP491** will tri-state the driver outputs. The **SP490** does not have a driver enable.

Receiver...

The receivers for both the **SP490** and **SP491** have differential inputs with an input sensitivity as low as $\pm 200\text{mV}$. Input impedance of the receivers is typically $15\text{K}\Omega$ ($12\text{K}\Omega$ minimum). A wide common mode range of -7V to +12V allows for large ground potential differences between systems. The receivers for both the **SP490** and **SP491** are equipped with the fail-safe feature. Fail-safe guarantees that the receiver output will be in a high state when the input is left unconnected.

The receiver of the **SP491** has a receiver enable control line which is active low. A logic low on $\overline{\text{REB}}$ (pin 3) of the **SP491** will enable the differential receiver. A logic high on $\overline{\text{REB}}$ (pin 3) of the **SP491** will tri-state the receiver.

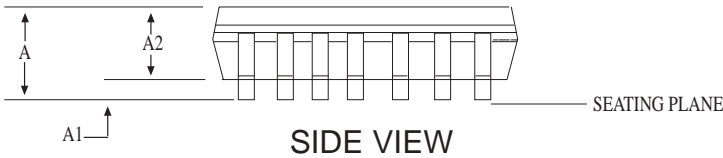
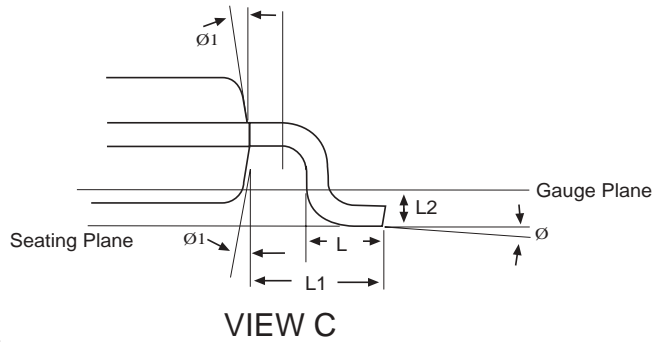
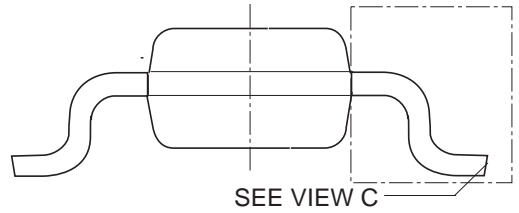
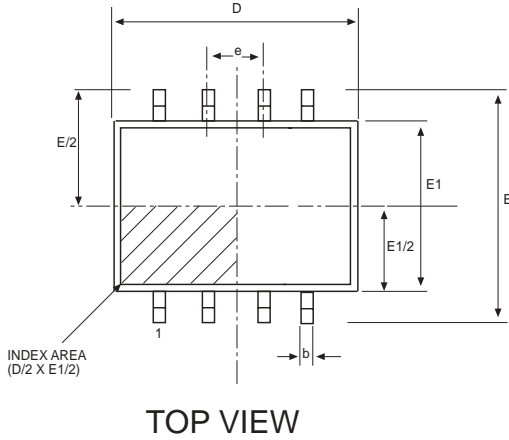

8 Pin NSOIC (JEDEC MS-012, AA - VARIATION)	DIMENSIONS Minimum/Maximum (mm)		
COMMON HEIGHT DIMENSION			
SYMBOL	MIN	NOM	MAX
A	1.35	-	1.75
A1	0.10	-	0.25
A2	1.25	-	1.65
b	0.31	-	0.51
c	0.17	-	0.25
D	4.90 BSC		
E	6.00 BSC		
E1	3.90 BSC		
e	1.27 BSC		
L	0.40	-	1.27
L1	1.04 REF		
L2	0.25 BSC		
Ø	0°	-	8°
Ø1	5°	-	15°

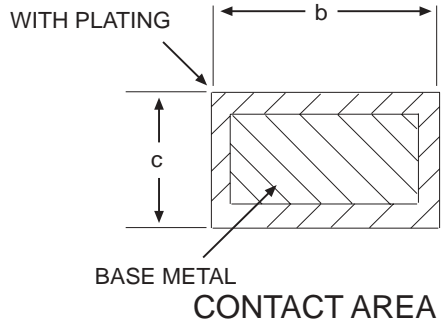

8 PIN NSOIC

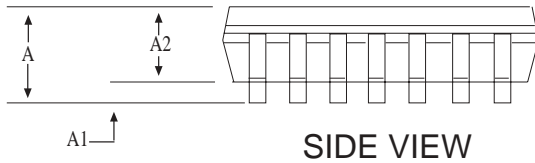
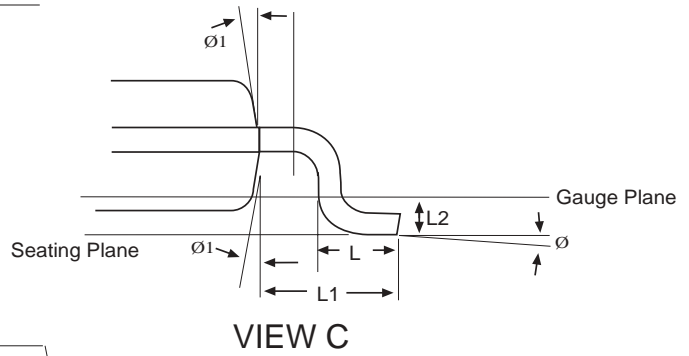
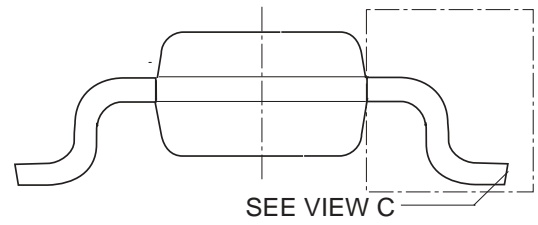
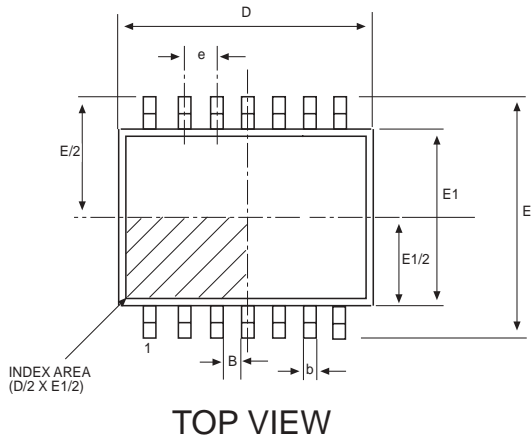

14 Pin NSOIC (JEDEC MS-012, AB - VARIATION)		DIMENSIONS Minimum/Maximum (mm)		
COMMON HEIGHT DIMENSION				
SYMBOL	MIN	NOM	MAX	
A	1.35	-	1.75	
A1	0.10	-	0.25	
A2	1.25	-	1.65	
b	0.31	-	0.51	
c	0.17	-	0.25	
D	8.65 BSC			
E	6.00 BSC			
E1	3.90 BSC			
e	1.27 BSC			
L	0.40	-	1.27	
L1	1.04 REF			
L2	0.25 BSC			
Ø	0°	-	8°	
Ø1	5°	-	15°	

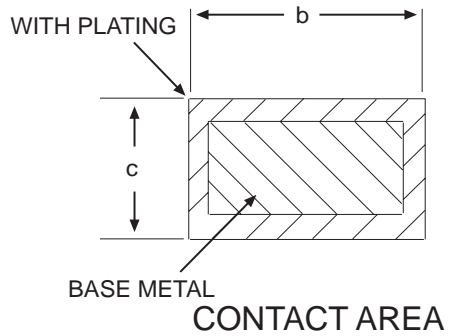

14 PIN NSOIC

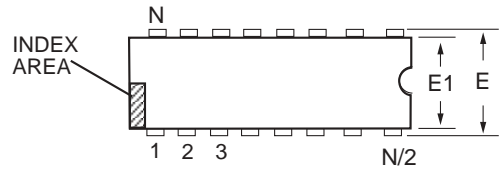
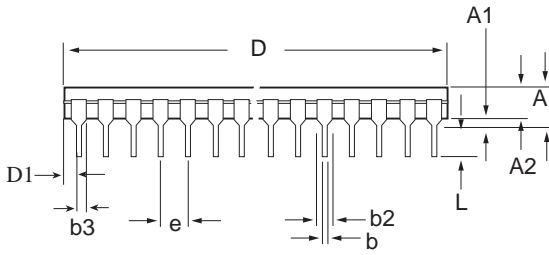

8 PIN PDIP JEDEC MS-001 (BA) Variation	Dimensions in inches		
	MIN	NOM	MAX
A	-	-	.210
A1	.015	-	-
A2	.115	.130	.195
b	.014	.018	.022
b2	.045	.060	.070
b3	.030	.039	.045
c	.008	.010	.014
D	.355	.365	.400
D1	.005	-	-
E	.300	.310	.325
E1	.240	.250	.280
e	.100 BSC		
eA	.300 BSC		
eB	-	-	.430
L	.115	.130	.150

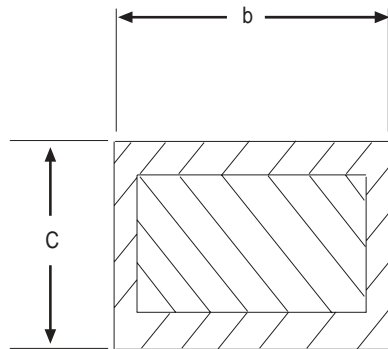
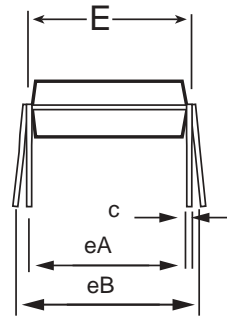

8 pin PDIP

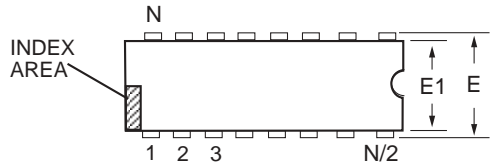
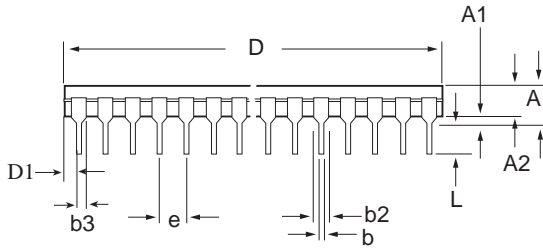

14 PIN PDIP JEDEC MS-001 (AA) Variation	Dimensions in inches		
	MIN	NOM	MAX
A	-	-	.210
A1	.015	-	-
A2	.115	.130	.195
b	.014	.018	.022
b2	.045	.060	.070
b3	.030	.039	.045
c	.008	.010	.014
D	.735	.750	.775
D1	.005	-	-
E	.300	.310	.325
E1	.240	.250	.280
e	.100 BSC		
eA	.300 BSC		
eB	-	-	.430
L	.115	.130	.150

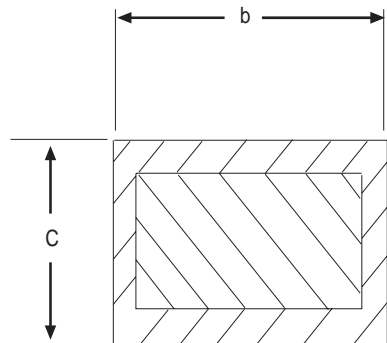
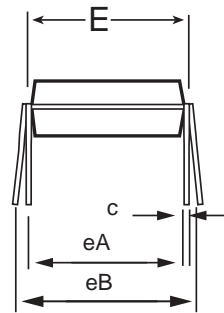

14 pin PDIP

ORDERING INFORMATION

Model	Temperature Range	Package
SP490CN	0°C to +70°C	8-Pin NSOIC
SP490CN/TR	0°C to +70°C	8-Pin NSOIC
SP490CS	0°C to +70°C	8-Pin PDIP
SP490EN	-40°C to +85°C	8-Pin NSOIC
SP490EN/TR	-40°C to +85°C	8-Pin NSOIC
SP490ES	-40°C to +85°C	8-Pin PDIP
SP491CN	0°C to +70°C	14-Pin NSOIC
SP491CN/TR	0°C to +70°C	14-Pin NSOIC
SP491CS	0°C to +70°C	14-Pin PDIP
SP491EN	-40°C to +85°C	14-Pin NSOIC
SP491EN/TR	-40°C to +85°C	14-Pin NSOIC
SP491ES	-40°C to +85°C	14-Pin PDIP

/TR = Tape and Reel

Pack quantity is 2500 for NSOIC.

Please consult factory for pricing and availability of various package and temperature options or price and availability of tape-on-reel.



ANALOG EXCELLENCE

Sipex Corporation

Headquarters and

Sales Office

233 South Hillview Drive

Milpitas, CA 95035

TEL: (408) 934-7500

FAX: (408) 935-7600

Sipex Corporation reserves the right to make changes to any products described herein. Sipex does not assume any liability arising out of the application or use of any product or circuit described hereing; neither does it convey any license under its patent rights nor the rights of others.