



PSD813F1-A

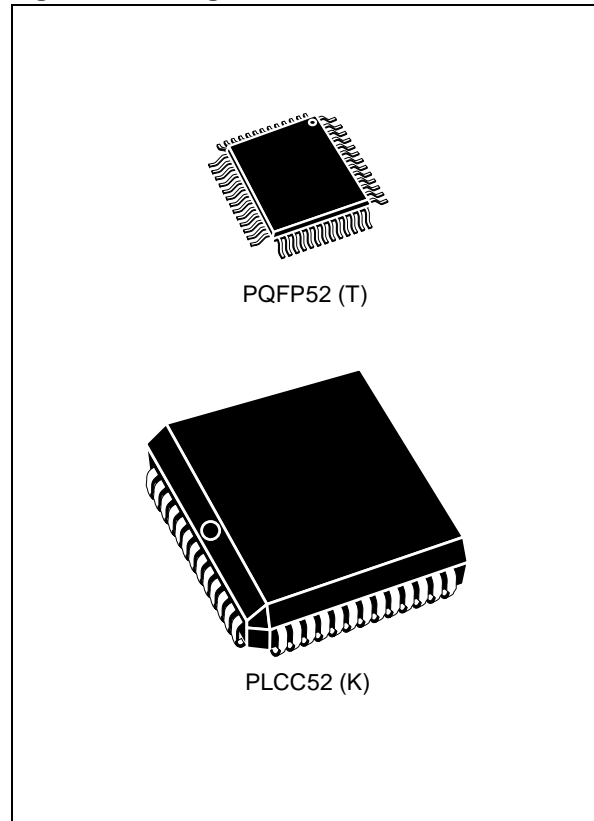
Flash In-System Programmable (ISP) Peripherals For 8-bit MCUs

PRELIMINARY DATA

FEATURES SUMMARY

- Single Supply Voltage:
 - 5 V \pm 10% for PSD813F1-A
 - 3.3 V \pm 10% for PSD813F1-AV
- Up to 1Mbit of Primary Flash Memory (8 uniform sectors)
- 256Kbit Secondary EEPROM (4 uniform sectors)
- Up to 16Kbit SRAM
- Over 3,000 Gates of PLD: DPLD and CPLD
- 27 Reconfigurable I/O ports
- Enhanced JTAG Serial Port
- Programmable power management
- High Endurance:
 - 100,000 Erase/Write Cycles of Flash Memory
 - 10,000 Erase/Write Cycles of EEPROM
 - 1,000 Erase/Write Cycles of PLD

Figure 1. Packages



Revision A Flash PSD

PSD813F1-A

Flash In-System-Programmable Microcontroller Peripherals

Table of Contents

| | | |
|-----|---|----|
| 1.0 | Introduction | 1 |
| 2.0 | Key Features | 2 |
| | PSD813F1 Block Diagram | 4 |
| 3.0 | General Information | 5 |
| 4.0 | PSD813F1 Family | 5 |
| 5.0 | PSD813F1 Architectural Overview | 6 |
| | 5.1 Memory | 6 |
| | 5.2 Page Register | 6 |
| | 5.3 PLDs | 6 |
| | 5.4 I/O Ports | 7 |
| | 5.5 Microcontroller Bus Interface | 7 |
| | 5.6 JTAG Port | 7 |
| | 5.7 In-System Programming | 8 |
| | 5.8 Power Management | 8 |
| 6.0 | Development System | 9 |
| 7.0 | PSD813F1 Pin Descriptions | 10 |
| 8.0 | PSD813F1 Register Description and Address Offset | 14 |
| 9.0 | PSD813F1 Functional Blocks | 15 |
| | 9.1 Memory Blocks | 15 |
| | 9.1.1 Main Flash and Secondary EEPROM | 15 |
| | 9.1.2 SRAM | 29 |
| | 9.1.3 Memory Select Signals | 29 |
| | 9.1.4 Page Register | 32 |
| | 9.2 PLDs | 33 |
| | 9.2.1 Decode PLD (DPLD) | 35 |
| | 9.2.2 Complex PLD (CPLD) | 35 |
| | 9.3 Microcontroller Bus Interface | 44 |
| | 9.3.1 PSD813F Interface to a Multiplexed 8-bit Bus | 44 |
| | 9.3.2 PSD813F Interface to a Non-Multiplexed 8-bit Bus | 44 |
| | 9.3.3 Data Byte Enable Reference | 47 |
| | 9.3.4 Microcontroller Interface Examples | 47 |
| | 9.4 I/O Ports | 52 |
| | 9.4.1 General Port Architecture | 52 |
| | 9.4.2 Port Operating Modes | 54 |
| | 9.4.3 Port Configuration Registers (PCRs) | 57 |
| | 9.4.4 Port Data Registers | 60 |
| | 9.4.5 Ports A and B – Functionality and Structure | 61 |
| | 9.4.6 Port C – Functionality and Structure | 63 |
| | 9.4.7 Port D – Functionality and Structure | 63 |
| | 9.5 Power Management | 67 |
| | 9.5.1 Automatic Power Down (APD) Unit and Power Down Mode | 67 |
| | 9.5.2 Other Power Saving Options | 71 |
| | 9.5.3 Reset and Power On Requirement | 72 |

Revision A Flash PSD
PSD813F1-A
Flash In-System-Programmable Microcontroller Peripherals

Table of Contents (cont.)

| | |
|---|-----|
| 9.6 Programming In-Circuit Using the JTAG Interface | 73 |
| 9.6.1 Standard JTAG Signals..... | 74 |
| 9.6.2 JTAG Extensions..... | 75 |
| 9.6.3 Security and Flash Memories and EEPROM Protection | 75 |
| Absolute Maximum Ratings..... | 76 |
| AD/DC Parameters..... | 77 |
| Example of PSD813F Typical Power Calculation at $V_{CC} = 5.0\text{ V}$ | 78 |
| PSD813F1 DC Characteristics (5 V \pm 10% Versions) | 80 |
| PSD813F1 AD/DC Parameters – CPLD Timing Parameters (5 V \pm 10% versions) | 81 |
| PSD813F1V DC Characteristics (3 V Versions) | 91 |
| PSD813F1V AC/DC Parameters – CPLD Timing Parameters (3 V versions)..... | 92 |
| Timing Diagrams | 100 |
| Programming..... | 107 |
| PSD813F1 Pin Assignments | 108 |
| PSD813F1 Package Information | 110 |
| Selector Guide..... | 113 |
| Part Number Construction..... | 114 |
| Ordering Information..... | 114 |
| Product Revisions..... | 115 |

**For additional information,
Call 800-832-6974
Fax: 510-657-8495
Web Site: <http://www.psdst.com>
E-mail: ask.psd@st.com**



*For additional information,
Call 800-832-6974
Fax: 510-657-8495
Web Site: <http://www.psdst.com>
E-mail: ask.psd@st.com*



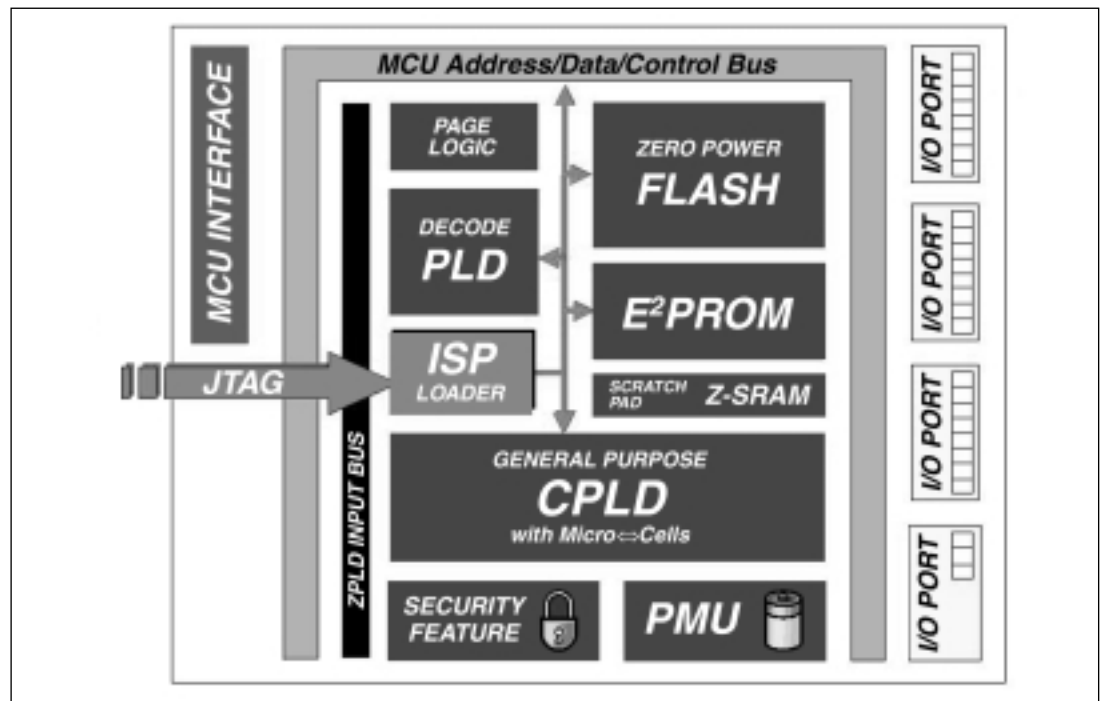
Programmable Peripheral Revision A Flash PSD PSD813F1-A Flash In-System-Programmable Microcontroller Peripherals

Preliminary

1.0 Introduction

The PSD813F1 family of Programmable Microcontroller (MCU) Peripherals brings In-System-Programmability (ISP) to Flash memory and programmable logic. The result is a simple and flexible solution for embedded designs. PSD813F1 devices combine many of the peripheral functions found in MCU based applications:

- 1 Mbit of Flash memory
- A second EEPROM memory
- Over 3,000 gates of Flash programmable logic
- SRAM
- Reconfigurable I/O ports
- Programmable power management.



PSD813F1 devices integrate an optimized “microcontroller macrocell” logic architecture called the Micro \leftrightarrow Cell™. The Micro \leftrightarrow Cell was created to address the unique requirements of embedded system designs. It allows direct connection between the system address/data bus and the internal PSD registers to simplify communication between the MCU and other supporting devices.

1.0 Introduction

(Cont.)

The PSD813F1 family offers two methods to program PSD Flash memory while the PSD is soldered to a circuit board.

❑ In-System Programming (ISP) JTAG

An IEEE 1149.1 compliant JTAG interface is included on the PSD enabling the entire device (Flash memory, EEPROM, the PLD, and all configuration) to be rapidly programmed while soldered to the circuit board. This requires no MCU participation, which means the PSD can be programmed anytime, even while completely blank.

The innovative JTAG interface to flash memories is an industry first, solving key problems faced by designers and manufacturing houses, such as:

- **First time programming** – How do I get firmware into the flash the very first time? JTAG is the answer, program the PSD while blank with no MCU involvement.
- **Inventory build-up of pre-programmed devices** – How do I maintain an accurate count of pre-programmed flash memory and PLD devices based on customer demand? How many and what version? JTAG is the answer, build your hardware with blank PSDs soldered directly to the board and then custom program just before they are shipped to customer. No more labels on chips and no more wasted inventory.
- **Expensive sockets** – How do I eliminate the need for expensive and unreliable sockets? JTAG is the answer. Solder the PSD directly to the circuit board. Program first time and subsequent times with JTAG. No need to handle devices and bend the fragile leads.

❑ In-Application Programming (IAP)

Two independent memory arrays (Flash and EEPROM) are included so the MCU can execute code from one memory while erasing and programming the other. Robust product firmware updates in the field are possible over any communication channel (CAN, Ethernet, UART, J1850, etc) using this unique architecture. Designers are relieved of these problems:

- **Simultaneous read and write to flash memory** – How can the MCU program the same memory from which it is executing code? It cannot. The PSD allows the MCU to operate the two memories concurrently, reading code from one while erasing and programming the other during IAP.
- **Complex memory mapping** – I have only a 64K-byte address space to start with. How can I map these two memories efficiently? A Programmable Decode PLD is the answer. The concurrent PSD memories can be mapped anywhere in MCU address space, segment by segment with extremely high address resolution. As an option, the secondary flash memory can be swapped out of the system memory map when IAP is complete. A built-in page register breaks the 64K-byte address limit.
- **Separate program and data space** – How can I write to flash or EEPROM memory while it resides in “program” space during field firmware updates, my MCU won’t allow it! The flash PSD provides means to “reclassify” flash or EEPROM memory as “data” space during IAP, then back to “program” space when complete.

PSDsoft — ST’s software development tool—now has the ability to generate ANSI-C compliant code for use with your target MCU. The code generated allows you to manipulate the non-volatile memory (NVM) within the PSD. Code examples are also provided for:

- Flash ISP via the UART of the host MCU
- Memory paging to execute code across several PSD memory pages
- Loading, reading, and manipulation of PSD Micro↔Cells by the MCU

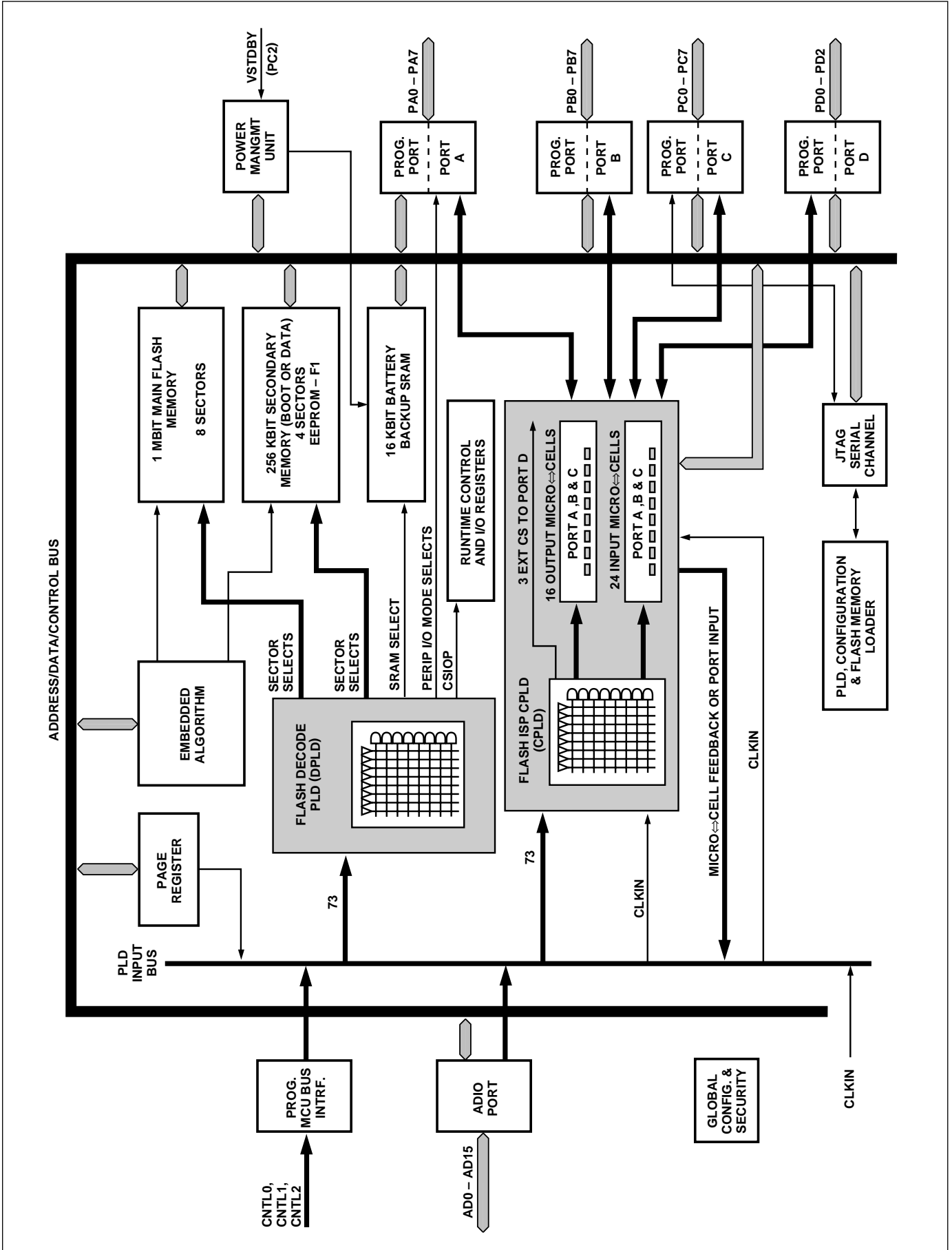
The PSD813F1 is available in a 52-pin PLCC package and a 64-pin plastic Thin Quad Flatpack (TQFP) package.



2.0 Key Features

- ❑ A simple interface to 8-bit microcontrollers that use either multiplexed or non-multiplexed busses. The bus interface logic uses the control signals generated by the microcontroller automatically when the address is decoded and a read or write is performed. A partial list of the MCU families supported include:
 - Intel 8031, 80196, 80186, 80C251, and 80386EX
 - Motorola 68HC11, 68HC16, 68HC12, and 683XX
 - Philips 8031 and 8051XA
 - Zilog Z80 and Z8
- ❑ Internal 1 Mbit Flash memory. This is the main Flash memory. It is divided into eight equal-sized blocks that can be accessed with user-specified addresses.
- ❑ Internal secondary 256 Kbit EEPROM memory. It is divided into four equal-sized blocks that can be accessed with user-specified addresses. This secondary memory brings the ability to execute code and update the main Flash **concurrently**.
- ❑ 16 Kbit scratchpad SRAM. The SRAM's contents can be protected from a power failure by connecting an external battery.
- ❑ Optional 64 byte One Time Programmable (OTP) memory that can be used for product configuration and calibration.
- ❑ CPLD with 16 Output Micro↔Cells (OMCs) and 24 Input Micro↔Cells (IMCs). The CPLD may be used to efficiently implement a variety of logic functions for internal and external control. Examples include state machines, loadable shift registers, and loadable counters.
- ❑ Decode PLD (DPLD) that decodes address for selection of internal memory blocks. The DPLD can also be used to generate external chip selects.
- ❑ 27 individually configurable I/O port pins that can be used for the following functions:
 - MCU I/Os
 - PLD I/Os
 - Latched MCU address output
 - Special function I/Os.
 - 16 of the I/O ports may be configured as open-drain outputs.
- ❑ Standby current as low as 50 μ A for 5 V devices, 25 μ A for 3 V devices.
- ❑ Built-in JTAG compliant serial port allows full-chip In-System Programmability (ISP). With it, you can program a blank device or reprogram a device in the factory or the field.
- ❑ Internal page register that can be used to expand the microcontroller address space by a factor of 256.
- ❑ Internal programmable Power Management Unit (PMU) that supports a low power mode called Power Down Mode. The PMU can automatically detect a lack of microcontroller activity and put the PSD813F1 into Power Down Mode.
- ❑ Erase/Write cycles:
 - Flash memory – 100,000 minimum
 - EEPROM – 10,000 minimum
 - PLD – 1,000 minimum
 - Data Retention: 15 year minimum at 90 degrees Celsius (for Main Flash, Boot, PLD and Configuration bits).

Figure 1. PSD813F1 Block Diagram



3.0 General Information

The PSD813F1 series architecture allows In-System Programming of all Memory, PLD Logic and Device Configuration. The embedded Input and Output Micro \Leftrightarrow Cells enable efficient implementation of user defined logic functions that require both software and hardware interaction. The devices eliminate the need for discrete 'glue' logic, and allow the development of entire systems using only a few highly integrated devices.

4.0 PSD813F1 Family

All PSD813F1 devices provide these features: 1 Mbit main Flash Memory, JTAG port, CPLD, DPLD, power management, and 27 I/O pins. The PSD813F1 also adds 64 bytes of OTP memory for any use (product serial number, calibration constants, etc.). Once written, the OTP memory can never be altered.

The following table summarizes the PSD813F1:

Table 1. PSD813F1 Product Matrix

| Part # | | I/O Pins | No. of Micro \Leftrightarrow Cells Input/Output | Serial ISP JTAG/ISC Port | Flash Main Memory Kbit (8 Sectors) | Additional Memory for Boot and/or Data (4 Sectors) | SRAM Kbit | Turbo Mode | Supply Voltage |
|-----------------|-----------|----------|---|--------------------------|------------------------------------|--|-----------|------------|----------------|
| PSD813F1 Family | Device | | | | | | | | |
| PSD813F1 | PSD813F1 | 27 | 24/16 | Yes | 1024 | 256 Kbit EEPROM | 16 | Yes | 5V |
| PSD813F1V | PSD813F1V | 27 | 24/16 | Yes | 1024 | 256 Kbit EEPROM | 16 | Yes | 3V |

5.0 PSD813F1 Architectural Overview

PSD813F1 devices contain several major functional blocks. Figure 1 on page 3 shows the architecture of the PSD813F1 device. The functions of each block are described briefly in the following sections. Many of the blocks perform multiple functions and are user configurable.

5.1 Memory

The PSD813F1 contains the following memories:

- A 1 Mbit Flash
- A secondary 256 Kbit EEPROM memory
- A 16 Kbit SRAM.

Each of the memories is briefly discussed in the following paragraphs. A more detailed discussion can be found in section 9.

The 1 Mbit Flash is the main memory of the PSD813F1. It is divided into eight equally-sized sectors that are individually selectable.

The 256 Kbit EEPROM or Flash is divided into four equally-sized sectors. Each sector is individually selectable.

The 16 Kbit SRAM is intended for use as a scratchpad memory or as an extension to the microcontroller SRAM. If an external battery is connected to the PSD813F1's Vstby pin, data will be retained in the event of a power failure.

Each block of memory can be located in a different address space as defined by the user. The access times for all memory types includes the address latching and DPLD decoding time.

5.2 Page Register

The eight-bit Page Register expands the address range of the microcontroller by up to 256 times. The paged address can be used as part of the address space to access external memory and peripherals or internal memory and I/O. The Page Register can also be used to change the address mapping of blocks of Flash memory into different memory spaces for in-circuit reprogramming.

5.3 PLDs

The device contains two PLD blocks, each optimized for a different function, as shown in Table 2. The functional partitioning of the PLDs reduces power consumption, optimizes cost/performance, and eases design entry.

The Decode PLD (DPLD) is used to decode addresses and generate chip selects for the PSD813F1 internal memory and registers. The CPLD can implement user-defined logic functions. The DPLD has combinatorial outputs. The CPLD has 16 Output Micro↔Cells and 3 combinatorial outputs. The PSD813F1 also has 24 Input Micro↔Cells that can be configured as inputs to the PLDs. The PLDs receive their inputs from the PLD Input Bus and are differentiated by their output destinations, number of Product Terms, and Micro↔Cells.

The PLDs consume minimal power by using Zero-Power design techniques. The speed and power consumption of the PLD is controlled by the Turbo Bit (ZPSD only) in the PMMR0 register and other bits in the PMMR2 registers. These registers are set by the microcontroller at runtime. There is a slight penalty to PLD propagation time when invoking the ZPSD features.

Table 2. PLD I/O Table

| Name | Abbreviation | Inputs | Outputs | Product Terms |
|-------------|--------------|--------|---------|---------------|
| Decode PLD | DPLD | 73 | 17 | 42 |
| Complex PLD | CPLD | 73 | 19 | 140 |

PSD813F1 Architectural Overview (cont.)

5.4 I/O Ports

The PSD813F1 has 27 I/O pins divided among four ports (Port A, B, C, and D). Each I/O pin can be individually configured for different functions. Ports A, B, C and D can be configured as standard MCU I/O ports, PLD I/O, or latched address outputs for microcontrollers using multiplexed address/data busses.

The JTAG pins can be enabled on Port C for In-System Programming (ISP).

Ports A and B can also be configured as a data port for a non-multiplexed bus or multiplexed Address/Data buses for certain types of 16-bit microcontrollers.

5.5 Microcontroller Bus Interface

The PSD813F1 easily interfaces with most 8-bit microcontrollers that have either multiplexed or non-multiplexed address/data busses. The device is configured to respond to the microcontroller's control signals, which are also used as inputs to the PLDs. Where there is a requirement to use a 16-bit data bus to interface to a 16-bit microcontroller, two PSDs must be used. Section 9.3.5 contains microcontroller interface examples.

5.6 JTAG Port

In-System Programming can be performed through the JTAG pins on Port C. This serial interface allows complete programming of the entire PSD813F1 device. A blank device can be completely programmed. The JTAG signals (TMS, TCK, $\overline{\text{TSTAT}}$, $\overline{\text{TERR}}$, TDI, TDO) can be multiplexed with other functions on Port C. Table 3 indicates the JTAG signals pin assignments.

Table 3. JTAG Signals on Port C

| Port C Pins | JTAG Signal |
|-------------|---------------------------|
| PC0 | TMS |
| PC1 | TCK |
| PC3 | $\overline{\text{TSTAT}}$ |
| PC4 | $\overline{\text{TERR}}$ |
| PC5 | TDI |
| PC6 | TDO |

PSD813F1 Architectural Overview (cont.)

5.7 In-System Programming

Using the JTAG signals on Port C, the entire PSD813F1 device can be programmed or erased without the use of the microcontroller. The main Flash memory can also be programmed in-system by the microcontroller executing the programming algorithms out of the EEPROM or SRAM. The EEPROM can be programmed the same way by executing out of the main Flash memory. The PLD logic or other PSD813F1 configuration can be programmed through the JTAG port or a device programmer. Table 4 indicates which programming methods can program different functional blocks of the PSD813F1.

Table 4. Methods of Programming Different Functional Blocks of the PSD813F1

| Functional Block | JTAG Programming | Device Programmer | In-System Parallel Programming |
|---------------------------|------------------|-------------------|--------------------------------|
| Main Flash memory | Yes | Yes | Yes |
| EEPROM memory | Yes | Yes | Yes |
| PLD Array (DPLD and CPLD) | Yes | Yes | No |
| PSD Configuration | Yes | Yes | No |
| Optional OTP Row | No | Yes | Yes |

5.8 Power Management Unit

The Power Management Unit (PMU) in the PSD813F1 gives the user control of the power consumption on selected functional blocks based on system requirements. The PMU includes an Automatic Power Down unit (APD) that will turn off device functions due to microcontroller inactivity. The APD unit has a Power Down Mode that helps reduce power consumption.

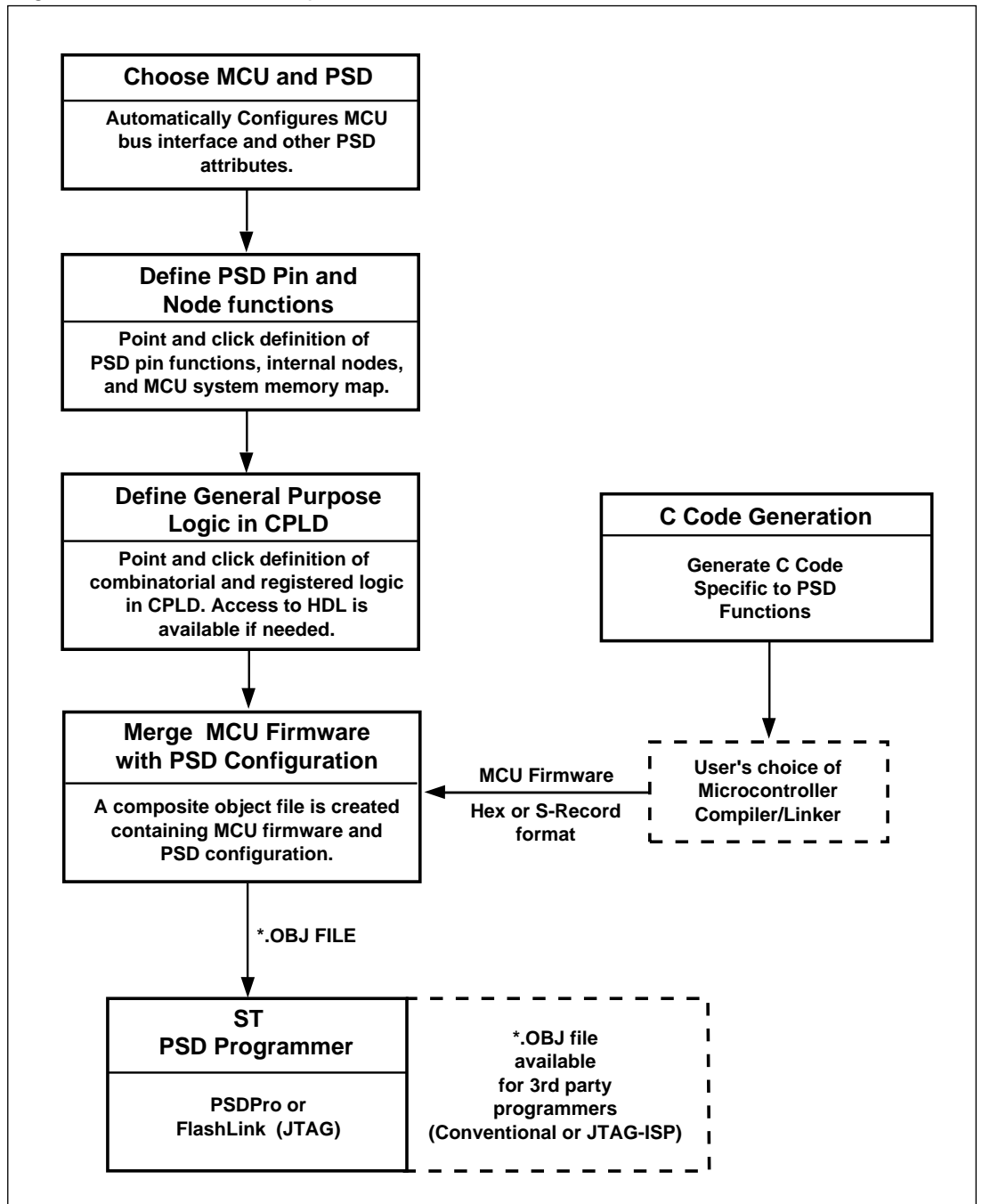
The PSD813F1 also has some bits that are configured at run-time by the MCU to reduce power consumption of the CPLD. The turbo bit in the PMMR0 register can be turned off and the CPLD will latch its outputs and go to sleep until the next transition on its inputs. Additionally, bits in the PMMR2 register can be set by the MCU to block signals from entering the CPLD to reduce power consumption. See section 9.5.

6.0 Development System

The PSD813F1 is supported by PSDsoft a Windows-based (95, 98, NT) software development tool. A PSD design is quickly and easily produced in a point and click environment. The designer does not need to enter Hardware Definition Language (HDL) equations (unless desired) to define PSD pin functions and memory map information. The general design flow is shown in Figure 2 below. PSDsoft is available from our web site (www.st.com/psm) or other distribution channels.

PSDsoft directly supports two low cost device programmers from ST, PSDpro and FlashLINK (JTAG). Both of these programmers may be purchased through your local rep/distributor, or directly from our web site using a credit card. The PSD813F1 is also supported by third party device programmers, see web site for current list.

Figure 2. PSDsoft Development Tool



7.0
Table 5.
PSD813F1
Pin
Descriptions

The following table describes the pin names and pin functions of the PSD813F1. Pins that have multiple names and/or functions are defined using PSD Configuration.

| Pin Name | Pin* | Type | Description |
|----------|-------|------|---|
| ADIO0-7 | 30-37 | I/O | <p>This is the lower Address/Data port. Connect your MCU address or address/data bus according to the following rules:</p> <ol style="list-style-type: none"> 1. If your MCU has a multiplexed address/data bus where the data is multiplexed with the lower address bits, connect AD[0:7] to this port. 2. If your MCU does not have a multiplexed address/data bus, or you are using an 80C251 in page mode, connect A[0:7] to this port. 3. If you are using an 80C51XA in burst mode, connect A4/D0 through A11/D7 to this port. <p>ALE or AS latches the address. The PSD drives data out only if the read signal is active and one of the PSD functional blocks was selected. The addresses on this port are passed to the PLDs.</p> |
| ADIO8-15 | 39-46 | I/O | <p>This is the upper Address/Data port. Connect your MCU address or address/data bus according to the following rules:</p> <ol style="list-style-type: none"> 1. If your MCU has a multiplexed address/data bus where the data is multiplexed with the lower address bits, connect A[8:15] to this port. 2. If your MCU does not have a multiplexed address/data bus, connect A[8:15] to this port. 3. If you are using an 80C251 in page mode, connect AD[8:15] to this port. 4. If you are using an 80C51XA in burst mode, connect A12/D8 through A19/D15 to this port. <p>ALE or AS latches the address. The PSD drives data out only if the read signal is active and one of the PSD functional blocks was selected. The addresses on this port are passed to the PLDs.</p> |
| CNTL0 | 47 | I | <p>The following control signals can be connected to this port, based on your MCU:</p> <ol style="list-style-type: none"> 1. \overline{WR} — active-low write input. 2. $R\overline{W}$ — active-high read/active low write input. <p>This port is connected to the PLDs. Therefore, these signals can be used in decode and other logic equations.</p> |
| CNTL1 | 50 | I | <p>The following control signals can be connected to this port, based on your MCU:</p> <ol style="list-style-type: none"> 1. \overline{RD} — active-low read input. 2. E — E clock input. 3. \overline{DS} — active-low data strobe input. 4. \overline{PSEN} — connect \overline{PSEN} to this port when it is being used as an active-low read signal. For example, when the 80C251 outputs more than 16 address bits, \overline{PSEN} is actually the read signal. <p>This port is connected to the PLDs. Therefore, these signals can be used in decode and other logic equations.</p> |

Table 5.
PSD813F1
Pin
Descriptions
(cont.)

| Pin Name | Pin* | Type | Description |
|--|--|------|---|
| CNTL2 | 49 | I | This port can be used to input the $\overline{\text{PSEN}}$ (Program Select Enable) signal from any MCU that uses this signal for code exclusively. If your MCU does not output a Program Select Enable signal, this port can be used as a generic input. This port is connected to the PLDs. |
| $\overline{\text{Reset}}$ | 48 | I | Active low reset input. Resets I/O Ports, PLD Micro \leftrightarrow Cells and some of the configuration registers. Must be active at power up. |
| PA0 PA1 PA2 PA3 PA4 PA5 PA6 PA7 | 29 28 27 25 24 23 22 21 | I/O | <p>These pins make up Port A. These port pins are configurable and can have the following functions:</p> <ol style="list-style-type: none"> 1. MCU I/O — write to or read from a standard output or input port. 2. CPLD Micro\leftrightarrowCell (McellAB0-7) outputs. 3. Inputs to the PLDs. 4. Latched address outputs (see Table 6). 5. Address inputs. For example, PA0-3 could be used for A[0:3] when using an 80C51XA in burst mode. 6. As the data bus inputs D[0:7] for non-multiplexed address/data bus MCUs. 7. D0/A16-D3/A19 in M37702M2 mode. 8. Peripheral I/O mode. <p>Note: PA0-3 can only output CMOS signals with an option for high slew rate. However, PA4-7 can be configured as CMOS or Open Drain Outputs.</p> |
| PB0 PB1 PB2 PB3 PB4 PB5 PB6 PB7 | 7 6 5 4 3 2 52 51 | I/O | <p>These pins make up Port B. These port pins are configurable and can have the following functions:</p> <ol style="list-style-type: none"> 1. MCU I/O — write to or read from a standard output or input port. 2. CPLD Micro\leftrightarrowCell (McellAB0-7 or McellBC0-7) outputs. 3. Inputs to the PLDs. 4. Latched address outputs (see Table 6). <p>Note: PB0-3 can only output CMOS signals with an option for high slew rate. However, PB4-7 can be configured as CMOS or Open Drain Outputs.</p> |
| PC0 | 20 | I/O | <p>PC0 pin of Port C. This port pin can be configured to have the following functions:</p> <ol style="list-style-type: none"> 1. MCU I/O — write to or read from a standard output or input port. 2. CPLD Micro\leftrightarrowCell (McellBC0) output. 3. Input to the PLDs. 4. TMS Input** for the JTAG Interface. <p>This pin can be configured as a CMOS or Open Drain output.</p> |
| PC1 | 19 | I/O | <p>PC1 pin of Port C. This port pin can be configured to have the following functions:</p> <ol style="list-style-type: none"> 1. MCU I/O — write to or read from a standard output or input port. 2. CPLD Micro\leftrightarrowCell (McellBC1) output. 3. Input to the PLDs. 4. TCK Input** for the JTAG Interface. <p>This pin can be configured as a CMOS or Open Drain output.</p> |

Table 5.
PSD813F1
Pin
Descriptions
(cont.)

| Pin Name | Pin* | Type | Description |
|----------|------|------|--|
| PC2 | 18 | I/O | <p>PC2 pin of Port C. This port pin can be configured to have the following functions:</p> <ol style="list-style-type: none"> 1. MCU I/O — write to or read from a standard output or input port. 2. CPLD Micro↔Cell (McellBC2) output. 3. Input to the PLDs. 4. Vstby — SRAM standby voltage input for SRAM battery backup. <p>This pin can be configured as a CMOS or Open Drain output.</p> |
| PC3 | 17 | I/O | <p>PC3 pin of Port C. This port pin can be configured to have the following functions:</p> <ol style="list-style-type: none"> 1. MCU I/O — write to or read from a standard output or input port. 2. CPLD Micro↔Cell (McellBC3) output. 3. Input to the PLDs. 4. \overline{TSTAT} output** for the JTAG interface. 5. Rdy/Bsy output for in-system parallel programming. <p>This pin can be configured as a CMOS or Open Drain output.</p> |
| PC4 | 14 | I/O | <p>PC4 pin of Port C. This port pin can be configured to have the following functions:</p> <ol style="list-style-type: none"> 1. MCU I/O — write to or read from a standard output or input port. 2. CPLD Micro↔Cell (McellBC4) output. 3. Input to the PLDs. 4. \overline{TERR} output** for the JTAG interface. 5. Vbaton — battery backup indicator output. Goes high when power is being drawn from an external battery. <p>This pin can be configured as a CMOS or Open Drain output.</p> |
| PC5 | 13 | I/O | <p>PC5 pin of Port C. This port pin can be configured to have the following functions:</p> <ol style="list-style-type: none"> 1. MCU I/O — write to or read from a standard output or input port. 2. CPLD Micro↔Cell (McellBC5) output. 3. Input to the PLDs. 4. TDI input** for the JTAG interface. <p>This pin can be configured as a CMOS or Open Drain output.</p> |
| PC6 | 12 | I/O | <p>PC6 pin of Port C. This port pin can be configured to have the following functions:</p> <ol style="list-style-type: none"> 1. MCU I/O — write to or read from a standard output or input port. 2. CPLD Micro↔Cell (McellBC6) output. 3. Input to the PLDs. 4. TDO output** for the JTAG interface. <p>This pin can be configured as a CMOS or Open Drain output.</p> |

Table 5.
PSD813F1
Pin
Descriptions
(cont.)

| Pin Name | Pin* | Type | Description |
|-----------------|---------|------|--|
| PC7 | 11 | I/O | PC7 pin of Port C. This port pin can be configured to have the following functions: 1. MCU I/O — write to or read from a standard output or input port. 2. CPLD Micro \leftrightarrow Cell (McellBC7) output. 3. Input to the PLDs. 4. DBE — active-low Data Byte Enable input from 68HC912 type MCUs. This pin can be configured as a CMOS or Open Drain output. |
| PD0 | 10 | I/O | PD0 pin of Port D. This port pin can be configured to have the following functions: 1. ALE/AS input latches address output from the MCU. 2. MCU I/O — write or read from a standard output or input port. 3. Input to the PLDs. 4. CPLD output (external chip select). |
| PD1 | 9 | I/O | PD1 pin of Port D. This port pin can be configured to have the following functions: 1. MCU I/O — write to or read from a standard output or input port. 2. Input to the PLDs. 3. CPLD output (external chip select). 4. CLKIN — clock input to the CPLD Micro \leftrightarrow Cells, the automatic power-down unit's power-down counter, and the CPLD AND array. |
| PD2 | 8 | I/O | PD2 pin of Port D. This port pin can be configured to have the following functions: 1. MCU I/O — write to or read from a standard output or input port. 2. Input to the PLDs. 3. CPLD output (external chip select). 4. CSI — chip select input. When low, the MCU can access the PSD memory and I/O. When high, the PSD memory blocks are disabled to conserve power. |
| V _{CC} | 15, 38 | | Power pins |
| GND | 1,16,26 | | Ground pins |

*The pin numbers in this table are for the PLCC package only. See the package information section for pin numbers on other package types.

**These functions can be multiplexed with other functions.

Table 6. I/O Port Latched Address Output Assignments*

| Microcontroller | Port A | | Port B | |
|-----------------------------|---------------|---------------|----------------|-----------------|
| | Port A (3:0) | Port A (7:4) | Port B (3:0) | Port B (7:4) |
| 8051XA (8-bit) | N/A | Address [7:4] | Address [11:8] | N/A |
| 80C251 (page mode) | N/A | N/A | Address [11:8] | Address [15:12] |
| All other 8-bit multiplexed | Address [3:0] | Address [7:4] | Address [3:0] | Address [7:4] |
| 8-bit non-multiplexed bus | N/A | N/A | Address [3:0] | Address [7:4] |

N/A = Not Applicable

*Refer to the I/O Port Section on how to enable the Latched Address Output function.



8.0 PSD813F1 Register Description and Address Offset

Table 7 shows the offset addresses to the PSD813F1 registers relative to the CSIOP base address. The CSIOP space is the 256 bytes of address that is allocated by the user to the internal PSD813F1 registers. Table 7 provides brief descriptions of the registers in CSIOP space. For a more detailed description, refer to section 9.

Table 7. Register Address Offset

| Register Name | Port A | Port B | Port C | Port D | Other * | Description |
|-----------------------|--------|--------|--------|--------|---------|---|
| Data In | 00 | 01 | 10 | 11 | | Reads Port pin as input, MCU I/O input mode |
| Control | 02 | 03 | | | | Selects mode between MCU I/O or Address Out |
| Data Out | 04 | 05 | 12 | 13 | | Stores data for output to Port pins, MCU I/O output mode |
| Direction | 06 | 07 | 14 | 15 | | Configures Port pin as input or output |
| Drive Select | 08 | 09 | 16 | 17 | | Configures Port pins as either CMOS or Open Drain on some pins, while selecting high slew rate on other pins. |
| Input Micro↔Cell | 0A | 0B | 18 | | | Reads Input Micro↔Cells |
| Enable Out | 0C | 0D | 1A | 1B | | Reads the status of the output enable to the I/O Port driver |
| Output Micro↔Cells AB | 20 | 20 | | | | Read – reads output of Micro↔Cells AB Write – loads Micro↔cell Flip-Flops |
| Output Micro↔Cells BC | | 21 | 21 | | | Read – reads output of Micro↔Cells BC Write – loads Micro↔cell Flip-Flops |
| Mask Micro↔Cells AB | 22 | 22 | | | | Blocks writing to the Output Micro↔Cells AB |
| Mask Micro↔Cells BC | | 23 | 23 | | | Blocks writing to the Output Micro↔Cells BC |
| Flash Protection | | | | | C0 | Read only – Flash Sector Protection |
| PSD/EE Protection | | | | | C2 | Read only – PSD Security and EEPROM Sector Protection |
| JTAG Enable | | | | | C7 | Enables JTAG Port |
| PMMR0 | | | | | B0 | Power Management Register 0 |
| PMMR2 | | | | | B4 | Power Management Register 2 |
| Page | | | | | E0 | Page Register |
| VM | | | | | E2 | Places PSD memory areas in Program and/or Data space on an individual basis. |

*Other registers that are not part of the I/O ports.

9.0 The PSD813F1 Functional Blocks

As shown in Figure 1, the PSD813F1 consists of six major types of functional blocks:

- Memory Blocks
- PLD Blocks
- Bus Interface
- I/O Ports
- Power Management Unit
- JTAG Interface

The functions of each block are described in the following sections. Many of the blocks perform multiple functions, and are user configurable.

9.1 Memory Blocks

The PSD813F1 has the following memory blocks:

- The main Flash memory
- Secondary EEPROM memory
- SRAM.

The memory select signals for these blocks originate from the Decode PLD (DPLD) and are user-defined in PSDsoft.

Table 8 summarizes the PSD813F1 memory blocks.

Table 8. Memory Blocks

| Device | Main Flash | EEPROM | SRAM |
|----------|------------|--------|------|
| PSD813F1 | 128KB | 32KB | 2KB |

9.1.1 Main Flash and Secondary EEPROM

The 1 Mbit main Flash memory block is divided evenly into eight 16 Kbyte sectors. The EEPROM memory is divided into four sectors of eight Kbytes each. Each sector of either memory can be separately protected from program and erase operations.

Flash memory may be erased on a sector-by-sector basis and programmed byte-by-byte. Flash sector erasure may be suspended while data is read from other sectors of memory and then resumed after reading.

EEPROM may be programmed byte-by-byte or sector-by-sector, and erasing is automatic and transparent. The integrity of the data can be secured with the help of Software Data Protection (SDP). Any write operation to the EEPROM is inhibited during the first five milliseconds following power-up.

During a program or erase of Flash, or during a write of the EEPROM, the status can be output on the Rdy/Bsy pin of Port C3. This pin is set up using PSDsoft Configuration.

The PSD813F1 Functional Blocks (cont.)

9.1.1.1 Memory Block Selects

The decode PLD in the PSD813F1 generates the chip selects for all the internal memory blocks (refer to the PLD section). Each of the eight Flash memory sectors have a Flash Select signal (FS0-FS7) which can contain up to three product terms. Each of the four EEPROM memory sectors have a Select signal (EES0-3 or CSBOOT0-3) which can contain up to three product terms. Having three product terms for each sector select signal allows a given sector to be mapped in different areas of system memory. When using a microcontroller with separate Program and Data space, these flexible select signals allow dynamic re-mapping of sectors from one space to the other.

9.1.1.2 The Ready/Busy Pin (PC3)

Pin PC3 can be used to output the Ready/Busy status of the PSD813F1. The output on the pin will be a '0' (Busy) when Flash or EEPROM memory blocks are being written to, **or** when the Flash memory block is being erased. The output will be a '1' (Ready) when no write or erase operation is in progress.

9.1.1.3 Memory Operation

The main Flash and EEPROM memory are addressed through the microcontroller interface on the PSD813F1 device. The microcontroller can access these memories in one of two ways:

- The microcontroller can execute a typical bus write or read **operation** just as it would if accessing a RAM or ROM device using standard bus cycles.
- The microcontroller can execute a specific **instruction** that consists of several write and read operations. This involves writing specific data patterns to special addresses within the Flash or EEPROM to invoke an embedded algorithm. These instructions are summarized in Table 9.

Typically, Flash memory can be read by the microcontroller using read operations, just as it would read a ROM device. However, Flash memory can only be erased and programmed with specific instructions. For example, the microcontroller cannot write a single byte directly to Flash memory as one would write a byte to RAM. To program a byte into Flash memory, the microcontroller must execute a program instruction sequence, then test the status of the programming event. This status test is achieved by a read operation or polling the Rdy/Busy pin (PC3).

The Flash memory can also be read by using special instructions to retrieve particular Flash device information (sector protect status and ID).

The EEPROM is a bit different. Data can be written to EEPROM memory using write operations, like writing to a RAM device, but the status of each write event must be checked by the microcontroller. A write event can be one to 64 contiguous bytes. The status test is very similar to that used for Flash memory (read operation or Rdy/Busy). Optionally, the EEPROM memory may be put into a Software Data Protect (SDP) mode where it requires instructions, rather than operations, to alter its contents. SDP mode makes writing to EEPROM much like writing to Flash memory.

The PSD813F1 Functional Blocks (cont.)

9.1.1.3.1 Instructions

An instruction is defined as a sequence of specific operations. Each received byte is sequentially decoded by the PSD and not executed as a standard write operation. The instruction is executed when the correct number of bytes are properly received and the time between two consecutive bytes is shorter than the time-out value. Some instructions are structured to include read operations after the initial write operations.

The sequencing of any instruction must be followed exactly. Any invalid combination of instruction bytes or time-out between two consecutive bytes while addressing Flash memory will reset the device logic into a read array mode (Flash memory reads like a ROM device). An invalid combination or time-out while addressing the EEPROM block will cause the offending byte to be interpreted as a single operation.

The PSD813F1 supports these instructions (see Table 9):

Flash memory:

- Erase memory by chip or sector
- Suspend or resume sector erase
- Program a byte
- Reset to read array mode
- Read Flash Identifier value
- Read sector protection status

EEPROM:

- Write data to OTP Row
- Read data from OTP Row
- Power down memory
- Enable Software Data Protect (SDP)
- Disable SDP
- Return from read OTP Row read mode or power down mode.

These instructions are detailed in Table 9. For efficient decoding of the instructions, the first two bytes of an instruction are the coded cycles and are followed by a command byte or confirmation byte. The coded cycles consist of writing the data AAh to address X555h during the first cycle and data 55h to address XAAAh during the second cycle. Address lines A15-A12 are don't cares during the instruction write cycles. However, the appropriate sector select signal (FSi or EESi) must be selected.

The
PSD813F1
Functional
Blocks
(cont.)

Table 9. Instructions

| Instruction | EEPROM Sector Select (EESi) | Flash Sector Select (FSi) (Note 2) | Cycle 1 | Cycle 2 | Cycle 3 | Cycle 4 | Cycle5 | Cycle 6 | Cycle 7 |
|--|-----------------------------|------------------------------------|-------------------|------------|-------------------|--|--------------|----------------------|-------------------------|
| Read Flash Identifier (Note 3, 5) | 0 | 1 | AAh @X555h | 55h @XAAAh | 90h @X555h | Read identifier with (A6,A1,A0 at 0,0,1) | | | |
| Read OTP Row (Note 4) | 1 | 0 | AAh @X555h | 55h @XAAAh | 90h @X555h | Read byte 1 | Read byte 2 | | Read byte N |
| Read Sector Protection Status (Notes 3, 5) | 0 | 1 | AAh @X555h | 55h @XAAAh | 90h @X555h | Read identifier with (A6,A1,A0 at 0,1,0) | | | |
| Program a Flash Byte (Note 5) | 0 | 1 | AAh @X555h | 55h @XAAAh | A0h @X555h | Data @ address | | | |
| Erase one Flash Sector (Note 5) | 0 | 1 | AAh @X555h | 55h @XAAAh | 80h @X555h | AAh @X555h | 55h @XAAAh | 30h @ Sector address | 30h @ Sector address(1) |
| Erase the whole Flash (Note 5) | 0 | 1 | AAh @X555h | 55h @XAAAh | 80h @X555h | AAh @X555h | 55h @XAAAh | 10h @X555h | |
| Suspend Sector Erase (Note 5) | 0 | 1 | B0h @ any address | | | | | | |
| Resume Sector Erase (Note 5) | 0 | 1 | 30h @ any address | | | | | | |
| EEPROM Power Down (Note 4) | 1 | 0 | AAh @X555h | 55h @XAAAh | 30h @X555h | | | | |
| SDP Enable/EEPROM Write (Note 4) | 1 | 0 | AAh @X555h | 55h @XAAAh | A0h @X555h | Write byte 1 | Write byte 2 | | Write byte N |
| SDP Disable (Note 4) | 1 | 0 | AAh @X555h | 55h @XAAAh | 80h @X555h | AAh @X555h | 55h @XAAAh | 20h @X555h | |
| Write in OTP Row (Notes 4, 6) | 1 | 0 | AAh @X555h | 55h @XAAAh | B0h @X555h | Write byte 1 | Write byte 2 | | Write byte N |
| Return (from OTP Read or EEPROM Power-Down) (Note 4) | 1 | 0 | F0h @ any address | | | | | | |
| Reset (Notes 3, 5) | 0 | 1 | AAh @X555h | 55h @XAAAh | F0h @ any address | | | | |
| Reset (short instruction) (Note 5) | 0 | 1 | F0h @ any address | | | | | | |

- NOTES:**
1. Additional sectors to be erased must be entered within 80 μ s. A Sector Address is any address within the Sector.
 2. Flash and EEPROM Sector Selects are active high. Addresses A15-A12 are don't cares in Instruction Bus Cycles.
 3. The Reset instruction is required to return to the normal read array mode if DQ5 goes high or after reading the Flash Identifier or Protection status.
 4. The MCU cannot invoke these instructions while executing code from EEPROM. The MCU must be operating from some other memory when these instructions are performed.
 5. The MCU cannot invoke these instructions while executing code from the same Flash memory for which the instruction is intended. The MCU must operate from some other memory when these instructions are executed.
 6. Writing to OTP Row is allowed only when SDP mode is disabled.

The
PSD813F1
Functional
Blocks
(cont.)

9.1.1.4 Power Down Instruction and Power Up Condition

9.1.1.4.1 EEPROM Power Down Instruction

The EEPROM can enter power down mode with the help of the EEPROM power down instruction (see Table 9). Once the EEPROM power down instruction is decoded, the EEPROM memory cannot be accessed unless a Return instruction (also in Table 9) is decoded. Alternately, this power down mode will automatically occur when the APD circuit is triggered (see section 9.5.1). Therefore, this instruction is not required if the APD circuit is used.

9.1.1.4.2 Power-Up Condition

The PSD813F1 internal logic is reset upon power-up to the read array mode. Any write operation to the EEPROM is inhibited during the first 5 msec following power-up. The FSi and EESi select signals, along with the write strobe signal, must be in the false state during power-up for maximum security of the data contents and to remove the possibility of a byte being written on the first edge of a write strobe signal. Any write cycle initiation is locked when V_{CC} is below VLKO.

9.1.1.5 Read

Under typical conditions, the microcontroller may read the Flash or EEPROM memory using read operations just as it would a ROM or RAM device. Alternately, the microcontroller may use read operations to obtain status information about a program or erase operation in progress. Lastly, the microcontroller may use instructions to read special data from these memories. The following sections describe these read functions.

9.1.1.5.1 Read the Contents of Memory

Main Flash is placed in the read array mode after power-up, chip reset, or a Reset Flash instruction (see Table 9). The microcontroller can read the memory contents of main Flash or EEPROM by using read operations any time the read operation is not part of an instruction sequence.

9.1.1.5.2 Read the Main Flash Memory Identifier

The main Flash memory identifier is read with an instruction composed of 4 operations: 3 specific write operations and a read operation (see Table 9). During the read operation, address bits A6, A1, and A0 must be 0,0,1, respectively, and the appropriate sector select signal (FSi) must be active. The Flash ID is E3h for the PSD813F1. The MCU can read the ID only when it is executing from the EEPROM.

9.1.1.5.3 Read the Main Flash Memory Sector Protection Status

The main Flash memory sector protection status is read with an instruction composed of 4 operations: 3 specific write operations and a read operation (see Table 9). During the read operation, address bits A6, A1, and A0 must be 0,1,0, respectively, while the chip select FSi designates the Flash sector whose protection has to be verified. The read operation will produce 01h if the Flash sector is protected, or 00h if the sector is not protected.

The sector protection status for all NVM blocks (main Flash or EEPROM) can be read by the microcontroller accessing the Flash Protection and PSD/EE Protection registers in PSD I/O space. See section 9.1.1.9.1 for register definitions.

The
PSD813F1
Functional
Blocks
(cont.)

9.1.1.5.4 Read the OTP Row

There are 64 bytes of One-Time-Programmable (OTP) memory that reside in EEPROM. These 64 bytes are in addition to the 32 Kbytes of EEPROM memory. A read of the OTP row is done with an instruction composed of at least 4 operations: 3 specific write operations and one to 64 read operations (see Table 9). During the read operation(s), address bit A6 must be zero, while address bits A5-A0 define the OTP Row byte to be read while any EEPROM sector select signal (EESi) is active. After reading the last byte, an EEPROM Return instruction must be executed (see Table 9).

9.1.1.5.5 Read the Erase/Program Status Bits

The PSD813F1 provides several status bits to be used by the microcontroller to confirm the completion of an erase or programming instruction of Flash memory. Bits are also available to show the status of writes to EEPROM. These status bits minimize the time that the microcontroller spends performing these tasks and are defined in Table 10. The status bits can be read as many times as needed.

Table 10. Status Bit

| | FSi/ CSB00Ti | EESi | DQ7 | DQ6 | DQ5 | DQ4 | DQ3 | DQ2 | DQ1 | DQ0 |
|--------|-----------------|-----------------|-----------------|----------------|---------------|-----|-----------------------|-----|-----|-----|
| Flash | V _{IH} | V _{IL} | Data Polling | Toggle Flag | Error Flag | X | Erase Time- out | X | X | X |
| EEPROM | V _{IL} | V _{IH} | Data Polling | Toggle Flag | X | X | X | X | X | X |

NOTES: 1. X = Not guaranteed value, can be read either 1 or 0.
2. DQ7-DQ0 represent the Data Bus bits, D7-D0.
3. FSi and EESi are active high.

For Flash memory, the microcontroller can perform a read operation to obtain these status bits while an erase or program instruction is being executed by the embedded algorithm. See section 9.1.1.7 for details.

For EEPROM not in SDP mode, the microcontroller can perform a read operation to obtain these status bits just after a data write operation. The microcontroller may write one to 64 bytes before reading the status bits. See section 9.1.1.6 for details.

For EEPROM in SDP mode, the microcontroller will perform a read operation to obtain these status bits while an SDP write instruction is being executed by the embedded algorithm. See section 9.1.1.3 for details.

The PSD813F1 Functional Blocks (cont.)

9.1.1.5.6 Data Polling Flag DQ7

When Erasing or Programming the Flash memory (or when Writing into the EEPROM memory), bit DQ7 outputs the complement of the bit being entered for Programming/Writing on DQ7. Once the Program instruction or the Write operation is completed, the true logic value is read on DQ7 (in a Read operation). Flash memory specific features:

- ❑ Data Polling is effective after the fourth Write pulse (for programming) or after the sixth Write pulse (for Erase). It must be performed at the address being programmed or at an address within the Flash sector being erased.
- ❑ During an Erase instruction, DQ7 outputs a '0'. After completion of the instruction, DQ7 will output the last bit programmed (it is a '1' after erasing).
- ❑ If the byte to be programmed is in a protected Flash sector, the instruction is ignored.
- ❑ If all the Flash sectors to be erased are protected, DQ7 will be set to '0' for about 100 μ s, and then return to the previous addressed byte. No erasure will be performed.

9.1.1.5.7 Toggle Flag DQ6

The PSD813F1 offers another way for determining when the EEPROM write or the Flash memory Program instruction is completed. During the internal Write operation and when either the FSi or EESi is true, the DQ6 will toggle from '0' to '1' and '1' to '0' on subsequent attempts to read any byte of the memory.

When the internal cycle is complete, the toggling will stop and the data read on the Data Bus D0-7 is the addressed memory byte. The device is now accessible for a new Read or Write operation. The operation is finished when two successive reads yield the same output data. Flash memory specific features:

- ❑ The Toggle bit is effective after the fourth Write pulse (for programming) or after the sixth Write pulse (for Erase).
- ❑ If the byte to be programmed belongs to a protected Flash sector, the instruction is ignored.
- ❑ If all the Flash sectors selected for erasure are protected, DQ6 will toggle to '0' for about 100 μ s and then return to the previous addressed byte.

9.1.1.5.8 Error Flag DQ5

During a correct Program or Erase, the Error bit will set to '0'. This bit is set to '1' when there is a failure during Flash byte programming, Sector erase, or Bulk Erase.

In the case of Flash programming, the Error Bit indicates the attempt to program a Flash bit(s) from the programmed state (0) to the erased state (1), which is not a valid operation. The Error bit may also indicate a timeout condition while attempting to program a byte.

In case of an error in Flash sector erase or byte program, the Flash sector in which the error occurred or to which the programmed byte belongs must no longer be used. Other Flash sectors may still be used. The Error bit resets after the Reset instruction.

9.1.1.5.9 Erase Time-out Flag DQ3 (Flash Memory only)

The Erase Timer bit reflects the time-out period allowed between two consecutive Sector Erase instructions. The Erase timer bit is set to '0' after a Sector Erase instruction for a time period of 100 μ s + 20% unless an additional Sector Erase instruction is decoded. After this time period or when the additional Sector Erase instruction is decoded, DQ3 is set to '1'.

The
PSD813F1
Functional
Blocks
(cont.)

9.1.1.6 Writing to the EEPROM

Data may be written a byte at a time to the EEPROM using simple write operations, much like writing to an SRAM. Unlike SRAM though, the completion of each byte write must be checked before the next byte is written. To speed up this process, the PSD813F1 offers a Page write feature to allow writing of several bytes before checking status.

To prevent inadvertent writes to EEPROM, the PSD813F1 offers a Software Data Protect (SDP) mode. Once enabled, SDP forces the MCU to “unlock” the EEPROM before altering its contents, much like Flash memory programming.

9.1.1.6.1 Write a Byte to EEPROM

A write operation is initiated when an EEPROM select signal (EESi) is true and the write strobe signal (wr) into the PSD813F1 is true. If the PSD813F1 detects no additional writes within 120 μ sec, an internal storage operation is initiated. Internal storage to EEPROM memory technology typically takes a few milliseconds to complete.

The status of the write operation is obtained by the MCU reading the Data Polling or Toggle bits (as detailed in section 9.1.1.5), or the Ready/Busy output pin (section 9.1.1.2).

Keep in mind that the MCU does not need to erase a location in EEPROM before writing it. Erasure is performed automatically as an internal process.

9.1.1.6.2 Write a Page to EEPROM

Writing data to EEPROM using page mode is more efficient than writing one byte at a time. The PSD813F1 EEPROM has a 64 byte volatile buffer that the MCU may fill before an internal EEPROM storage operation is initiated. Page mode timing approaches a 64:1 advantage over the time it takes to write individual bytes.

To invoke page mode, the MCU must write to EEPROM locations within a single page, with no more than 120 μ sec between individual byte writes. A single page means that address lines A14 to A6 must remain constant. The MCU may write to the 64 locations on a page in any order, which is determined by address lines A5 to A0. As soon as 120 μ sec have expired after the last page write, the internal EEPROM storage process begins and the MCU checks programming status. Status is checked the same way it is for byte writes, described above.

Note: be aware that if the upper address bits (A14 to A6) change during page write operations, loss of data may occur. Ensure that all bytes for a given page have been successfully stored in the EEPROM before proceeding to the next page. Correct management of MCU interrupts during EEPROM page write operations is essential.

9.1.1.6.3 EEPROM Software Data Protect (SDP)

The SDP feature is useful for protecting the contents of EEPROM from inadvertent write cycles that may occur during uncontrolled MCU bus conditions. These may happen if the application software gets lost or when V_{CC} is not within normal operating range.

Instructions from the MCU are used to enable and disable SDP mode (see Table 9). Once enabled, the MCU must write an instruction sequence to EEPROM before writing data (much like writing to Flash memory). SDP mode can be used for both byte and page writes to EEPROM. The device will remain in SDP mode until the MCU issues a valid SDP disable instruction.

PSD813F1 devices are shipped with SDP mode disabled. However, within PSDsoft, SDP mode may be enabled as part of programming the device with a device programmer (PSDpro).

The PSD813F1 Functional Blocks (cont.)

9.1.1.6.3 EEPROM Software Data Protect (SDP) (cont.)

To enable SDP mode at run time, the MCU must write three specific data bytes at three specific memory locations, as shown in Figure 3. Any further writes to EEPROM when SDP is set will require this same sequence, followed by the byte(s) to write. The first SDP enable sequence can be followed directly by the byte(s) to be written.

To disable SDP mode, the MCU must write specific bytes to six specific locations, as shown in Figure 4.

The MCU must not be executing code from EEPROM when these instructions are invoked. The MCU must be operating from some other memory when enabling or disabling SDP mode.

The state of SDP mode is not changed by power on/off sequences (nonvolatile). When either the SDP enable or SDP disable instructions are issued from the MCU, the MCU must use the Toggle bit (status bit DQ6) or the Ready/Busy output pin to check programming status. The Ready/Busy output is driven low from the first write of AAh @ 555h until the completion of the internal storage sequence. Data Polling (status bit DQ7) is not supported when issuing the SDP enable or SDP disable commands.

Note: Using the SDP sequence (enabling, disabling, or writing data) is initiated when specific bytes are written to addresses on specific “pages” of EEPROM memory, with no more than 120 µsec between writes. The addresses 555h and AAAh are located on different pages of EEPROM. This is how the PSD813F1 distinguishes these instruction sequences from ordinary writes to EEPROM, which are expected to be within a single EEPROM page.

Figure 3. EEPROM SDP Enable Flowcharts

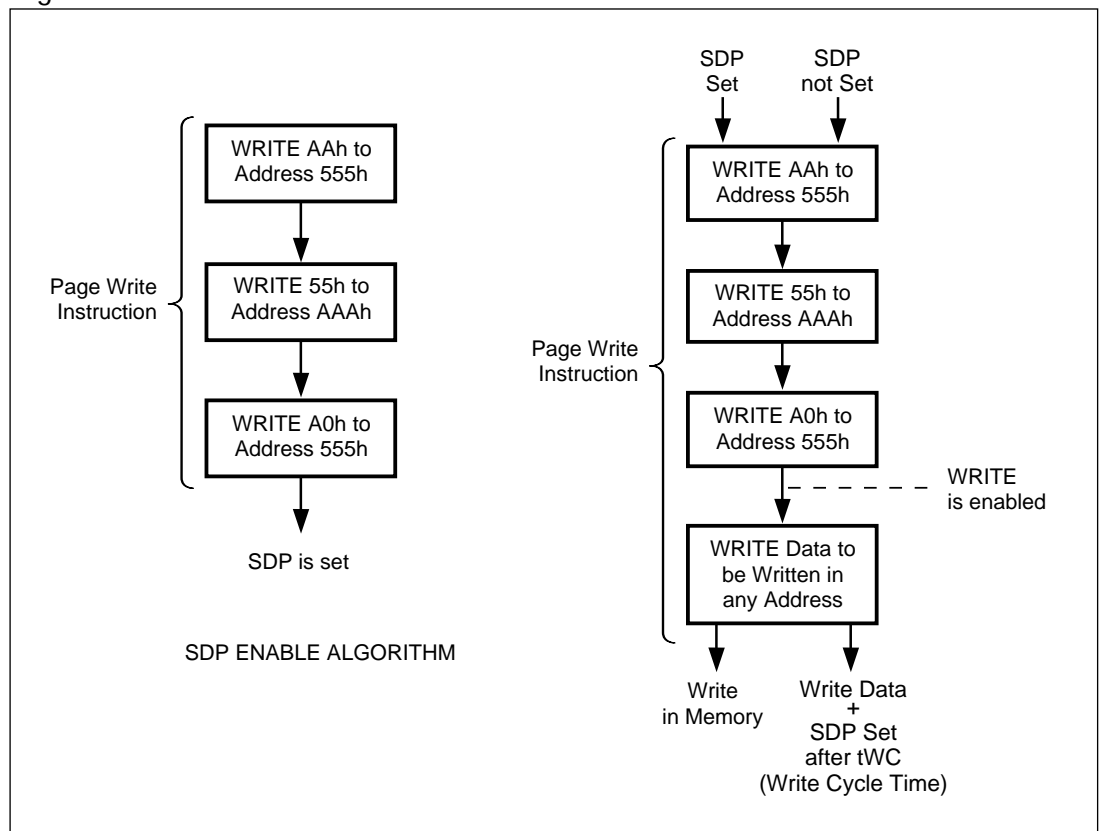
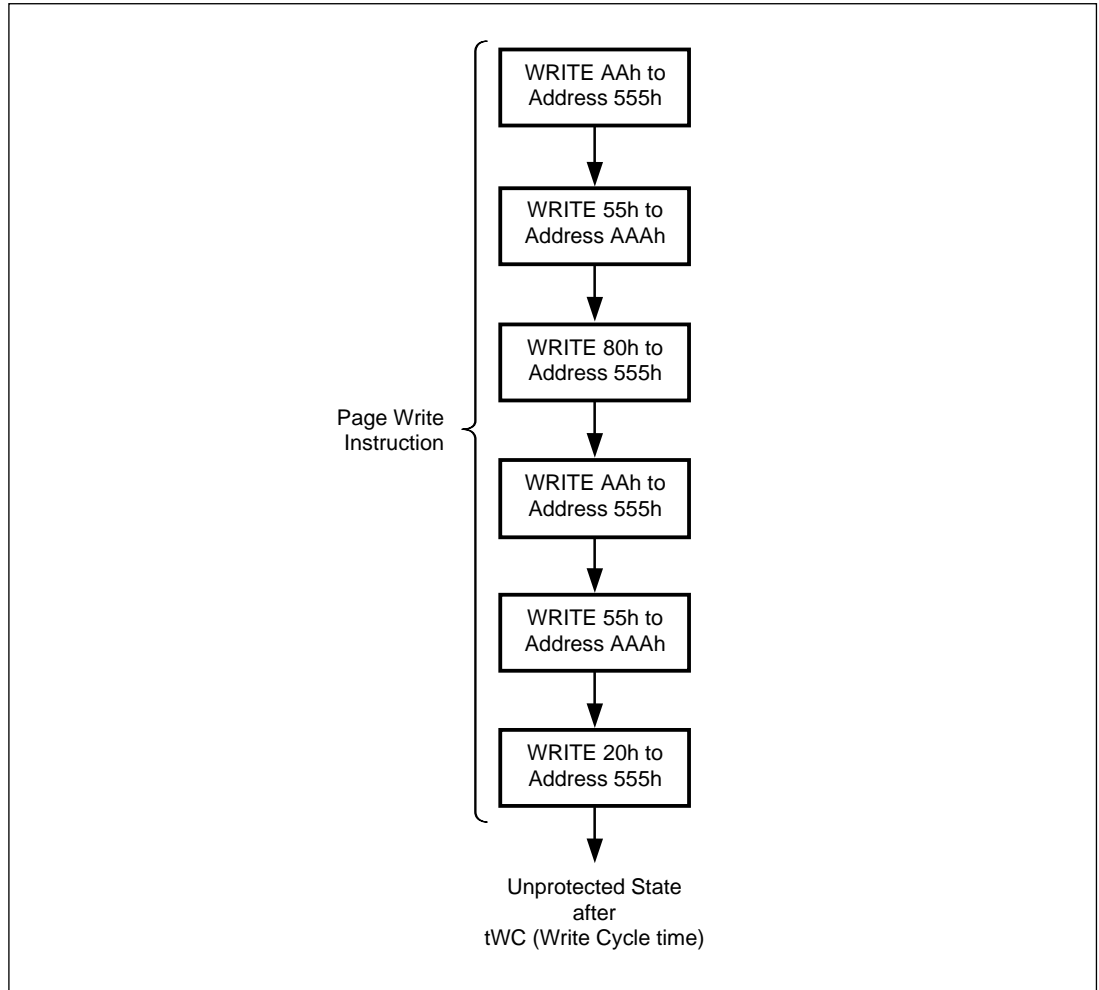


Figure 4. Software Data Protection Disable Flow Chart



9.1.1.6.4 Write OTP Row

Writing to the OTP row (64 bytes) can only be done once per byte, and is enabled by an instruction. This instruction is composed of three specific Write operations of data bytes at three specific memory locations followed by the data to be stored in the OTP row (refer to Table 9). During the write operations, address bit A6 must be zero, while address bits A5-A0 define the OTP Row byte to be written while any EEPROM Sector Select signal (EESi) is active. Writing the OTP Row is allowed only when SDP mode is not enabled.

9.1.1.7 Programming Flash Memory

Flash memory must be erased prior to being programmed. The MCU may erase Flash memory all at once or by-sector, but not byte-by-byte. A byte of Flash memory erases to all logic ones (FF hex), and its bits are programmed to logic zeros. Although erasing Flash memory occurs on a sector basis, programming Flash memory occurs on a byte basis.

The PSD813F1 main Flash and optional boot Flash require the MCU to send an instruction to program a byte or perform an erase function (see Table 9). This differs from EEPROM, which can be programmed with simple MCU bus write operations (unless EEPROM SDP mode is enabled).

Once the MCU issues a Flash memory program or erase instruction, it must check for the status of completion. The embedded algorithms that are invoked inside the PSD813F1 support several means to provide status to the MCU. Status may be checked using any of three methods: Data Polling, Data Toggle, or the Ready/Busy output pin.

The
PSD813F1
Functional
Blocks
(cont.)

9.1.1.7.1 Data Polling

Polling on DQ7 is a method of checking whether a Program or Erase instruction is in progress or has completed. Figure 5 shows the Data Polling algorithm.

When the MCU issues a programming instruction, the embedded algorithm within the PSD813F1 begins. The MCU then reads the location of the byte to be programmed in Flash to check status. Data bit DQ7 of this location becomes the compliment of data bit 7 of the original data byte to be programmed. The MCU continues to poll this location, comparing DQ7 and monitoring the Error bit on DQ5. When the DQ7 matches data bit 7 of the original data, and the Error bit at DQ5 remains '0', then the embedded algorithm is complete. If the Error bit at DQ5 is '1', the MCU should test DQ7 again since DQ7 may have changed simultaneously with DQ5 (see Figure 5).

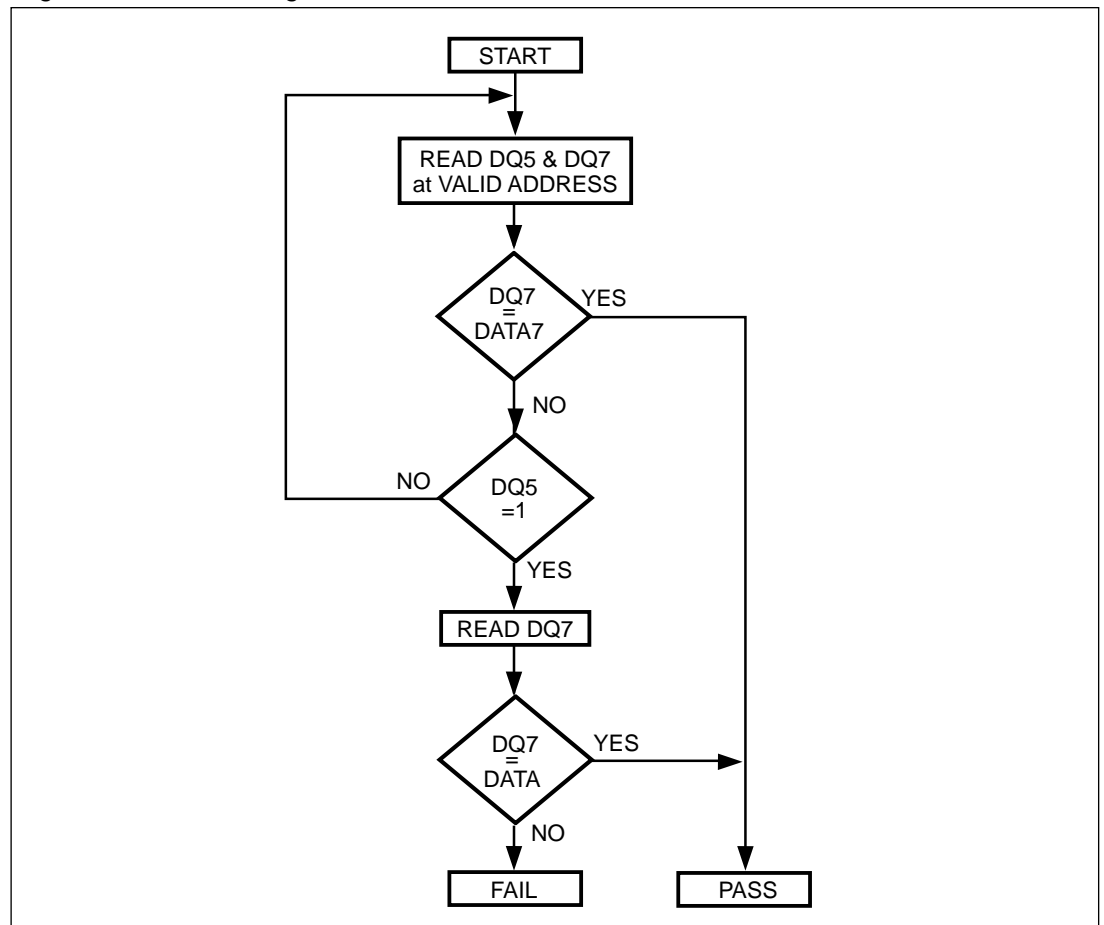
The Error bit at DQ5 will be set if either an internal timeout occurred while the embedded algorithm attempted to program the byte or if the MCU attempted to program a '1' to a bit that was not erased (not erased is logic '0').

It is suggested (as with all Flash memories) to read the location again after the embedded programming algorithm has completed to compare the byte that was written to Flash with the byte that was intended to be written.

When using the Data Polling method after an erase instruction, Figure 5 still applies. However, DQ7 will be '0' until the erase operation is complete. A '1' on DQ5 will indicate a timeout failure of the erase operation, a '0' indicates no error. The MCU can read any location within the sector being erased to get DQ7 and DQ5.

PSDsoft will generate ANSI C code functions which implement these Data Polling algorithms.

Figure 5. Data Polling Flow Chart



The PSD813F1 Functional Blocks (cont.)

9.1.1.7.2 Data Toggle

Checking the Data Toggle bit on DQ6 is a method of determining whether a Program or Erase instruction is in progress or has completed. Figure 6 shows the Data Toggle algorithm.

When the MCU issues a programming instruction, the embedded algorithm within the PSD813F1 begins. The MCU then reads the location of the byte to be programmed in Flash to check status. Data bit DQ6 of this location will toggle each time the MCU reads this location until the embedded algorithm is complete. The MCU continues to read this location, checking DQ6 and monitoring the Error bit on DQ5. When DQ6 stops toggling (two consecutive reads yield the same value), and the Error bit on DQ5 remains '0', then the embedded algorithm is complete. If the Error bit on DQ5 is '1', the MCU should test DQ6 again, since DQ6 may have changed simultaneously with DQ5 (see Figure 6).

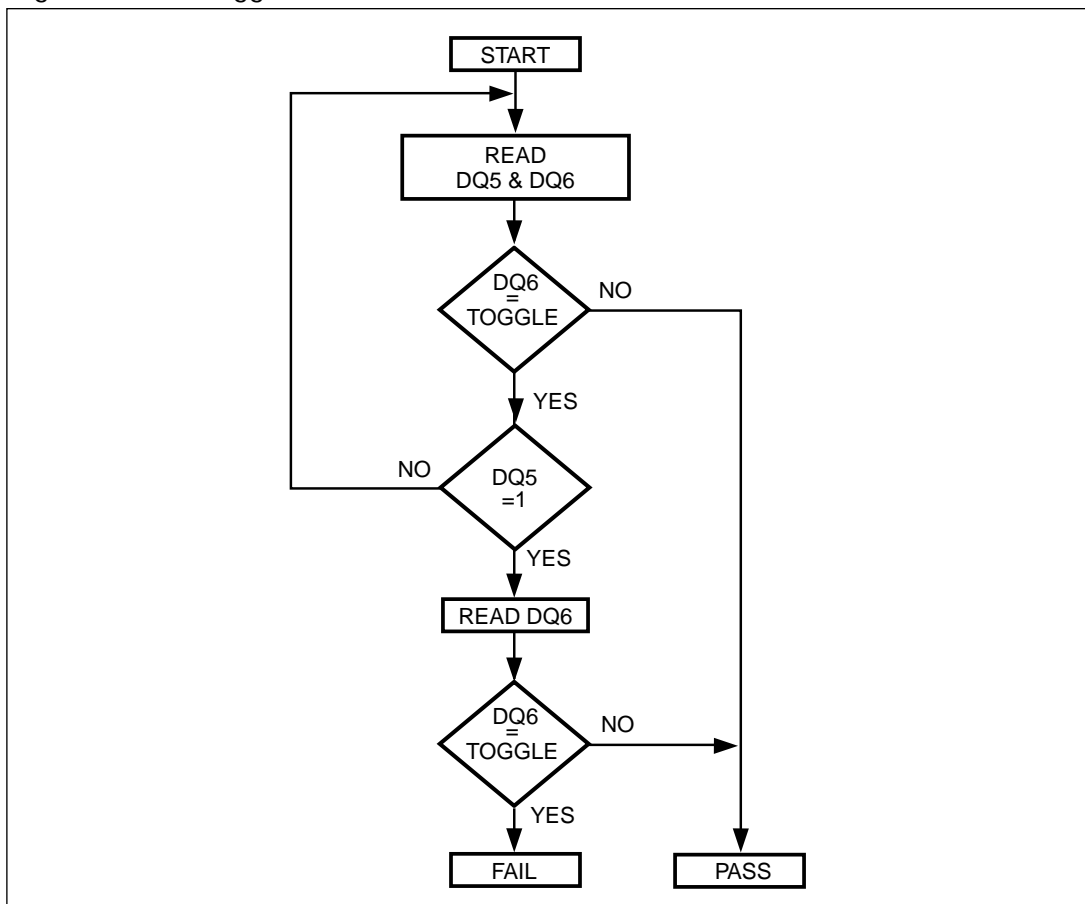
The Error bit at DQ5 will be set if either an internal timeout occurred while the embedded algorithm attempted to program the byte, or if the MCU attempted to program a '1' to a bit that was not erased (not erased is logic '0').

It is suggested (as with all Flash memories) to read the location again after the embedded programming algorithm has completed to compare the byte that was written to Flash with the byte that was intended to be written.

When using the Data Toggle method after an erase instruction, Figure 6 still applies. DQ6 will toggle until the erase operation is complete. A '1' on DQ5 will indicate a timeout failure of the erase operation, a '0' indicates no error. The MCU can read any location within the sector being erased to get DQ6 and DQ5.

PSDsoft will generate ANSI C code functions which implement these Data Toggling algorithms.

Figure 6. Data Toggle Flow Chart



The
PSD813F1
Functional
Blocks
(cont.)

9.1.1.8 Erasing Flash Memory

9.1.1.8.1. Flash Bulk Erase Instruction

The Flash Bulk Erase instruction uses six write operations followed by a Read operation of the status register, as described in Table 9. If any byte of the Bulk Erase instruction is wrong, the Bulk Erase instruction aborts and the device is reset to the Read Flash memory status.

During a Bulk Erase, the memory status may be checked by reading status bits DQ5, DQ6, and DQ7, as detailed in section 9.1.1.7. The Error bit (DQ5) returns a '1' if there has been an Erase Failure (maximum number of erase cycles have been executed).

It is not necessary to program the array with 00h because the PSD813F1 will automatically do this before erasing to 0FFh.

During execution of the Bulk Erase instruction, the Flash memory will not accept any instructions.

9.1.1.8.2 Flash Sector Erase Instruction

The Sector Erase instruction uses six write operations, as described in Table 9. Additional Flash Sector Erase confirm commands and Flash sector addresses can be written subsequently to erase other Flash sectors in parallel, without further coded cycles, if the additional instruction is transmitted in a shorter time than the timeout period of about 100 μ s. The input of a new Sector Erase instruction will restart the time-out period.

The status of the internal timer can be monitored through the level of DQ3 (Erase time-out bit). If DQ3 is '0', the Sector Erase instruction has been received and the timeout is counting. If DQ3 is '1', the timeout has expired and the PSD813F1 is busy erasing the Flash sector(s). Before and during Erase timeout, any instruction other than Erase suspend and Erase Resume will abort the instruction and reset the device to Read Array mode. It is not necessary to program the Flash sector with 00h as the PSD813F1 will do this automatically before erasing (byte=FFh).

During a Sector Erase, the memory status may be checked by reading status bits DQ5, DQ6, and DQ7, as detailed in section 9.1.1.7.

During execution of the erase instruction, the Flash block logic accepts only Reset and Erase Suspend instructions. Erasure of one Flash sector may be suspended, in order to read data from another Flash sector, and then resumed.

9.1.1.8.3 Flash Erase Suspend Instruction

When a Flash Sector Erase operation is in progress, the Erase Suspend instruction will suspend the operation by writing 0B0h to any address when an appropriate Chip Select (FSi) is true. (See Table 9). This allows reading of data from another Flash sector after the Erase operation has been suspended. Erase suspend is accepted only during the Flash Sector Erase instruction execution and defaults to read array mode. An Erase Suspend instruction executed during an Erase timeout will, in addition to suspending the erase, terminate the time out.

The Toggle Bit DQ6 stops toggling when the PSD813F1 internal logic is suspended. The toggle Bit status must be monitored at an address within the Flash sector being erased. The Toggle Bit will stop toggling between 0.1 μ s and 15 μ s after the Erase Suspend instruction has been executed. The PSD813F1 will then automatically be set to Read Flash Block Memory Array mode.

If an Erase Suspend instruction was executed, the following rules apply:

- Attempting to read from a Flash sector that was being erased will output invalid data.
- Reading from a Flash sector that was **not** being erased is valid.
- The Flash memory **cannot** be programmed, and will only respond to Erase Resume and Reset instructions (read is an operation and is OK).
- If a Reset instruction is received, data in the Flash sector that was being erased will be invalid.

The PSD813F1 Functional Blocks (cont.)

9.1.1.8.4 Flash Erase Resume Instruction

If an Erase Suspend instruction was previously executed, the erase operation may be resumed by this instruction. The Erase Resume instruction consists of writing 030h to any address while an appropriate Chip Select (FSi) is true. (See Table 9.)

9.1.1.9 Flash and EEPROM Memory Specific Features

9.1.1.9.1 Flash and EEPROM Sector Protect

Each Flash and EEPROM sector can be separately protected against Program and Erase functions. Sector Protection provides additional data security because it disables all program or erase operations. This mode can be activated through the JTAG Port or a Device Programmer.

Sector protection can be selected for each sector using the PSDsoft Configuration program. This will automatically protect selected sectors when the device is programmed through the JTAG Port or a Device Programmer. Flash and EEPROM sectors can be unprotected to allow updating of their contents using the JTAG Port or a Device Programmer. The microcontroller can read (but cannot change) the sector protection bits.

Any attempt to program or erase a protected Flash or EEPROM sector will be ignored by the device. The Verify operation will result in a read of the protected data. This allows a guarantee of the retention of the Protection status.

The sector protection status can be read by the MCU through the Flash protection and PSD/EE protection registers (CSIOP). See Table 11.

Table 11. Sector Protection/Security Bit Definition

Flash Protection Register

| Bit 7 | Bit 6 | Bit 5 | Bit 4 | Bit 3 | Bit 2 | Bit 1 | Bit 0 |
|-----------|-----------|-----------|-----------|-----------|-----------|-----------|-----------|
| Sec7_Prot | Sec6_Prot | Sec5_Prot | Sec4_Prot | Sec3_Prot | Sec2_Prot | Sec1_Prot | Sec0_Prot |

Bit Definitions:

- Sec<i>_Prot** 1 = Flash <i> is write protected.
- Sec<i>_Prot** 0 = Flash <i> is not write protected.

PSD/EE Protection Register

| Bit 7 | Bit 6 | Bit 5 | Bit 4 | Bit 3 | Bit 2 | Bit 1 | Bit 0 |
|--------------|-------|-------|-------|-----------|-----------|-----------|-----------|
| Security_Bit | * | * | * | Sec3_Prot | Sec2_Prot | Sec1_Prot | Sec0_Prot |

*: Not used.

Bit Definitions:

- Sec<i>_Prot** 1 = EEPROM Boot Sector <i> is write protected.
- Sec<i>_Prot** 0 = EEPROM Boot Sector <i> is not write protected.
- Security_Bit** 0 = Security Bit in device has not been set.
- Security_Bit** 1 = Security Bit in device has been set.

9.1.1.9.2 Reset Instruction

The Reset instruction resets the internal memory logic state machine in a few milliseconds. Reset is an instruction of either one write operation or three write operations (refer to Table 9).



The PSD813F1 Functional Blocks (cont.)

9.1.2 SRAM

The SRAM is a 16 Kbit (2K x 8) memory. The SRAM is enabled when RS0—the SRAM chip select output from the DPLD—is high. RS0 can contain up to two product terms, allowing flexible memory mapping.

The SRAM can be backed up using an external battery. The external battery should be connected to the Vstby pin (PC2). If you have an external battery connected to the PSD813F1, the contents of the SRAM will be retained in the event of a power loss. The contents of the SRAM will be retained so long as the battery voltage remains at 2V or greater. If the supply voltage falls below the battery voltage, an internal power switchover to the battery occurs.

Pin PC4 can be configured as an output that indicates when power is being drawn from the external battery. This Vbaton signal will be high with the supply voltage falls below the battery voltage and the battery on PC2 is supplying power to the internal SRAM.

The chip select signal (RS0) for the SRAM, Vstby, and Vbaton are all configured using PSDsoft Configuration.

9.1.3 Memory Select Signals

The main Flash (FSi), EEPROM (EESi), and SRAM (RS0) memory select signals are all outputs of the DPLD. They are setup by entering equations for them in PSDsoft. The following rules apply to the equations for the internal chip select signals:

1. Flash memory and EEPROM memory sector select signals must **not** be larger than the physical sector size.
2. Any main Flash memory sector must **not** be mapped in the same memory space as another Flash sector.
3. An EEPROM memory sector must **not** be mapped in the same memory space as another EEPROM sector.
4. SRAM, I/O, and Peripheral I/O spaces must **not** overlap.
5. An EEPROM memory sector **may** overlap a main Flash memory sector. In case of overlap, priority will be given to the EEPROM.
6. SRAM, I/O, and Peripheral I/O spaces **may** overlap any other memory sector. Priority will be given to the SRAM, I/O, or Peripheral I/O.

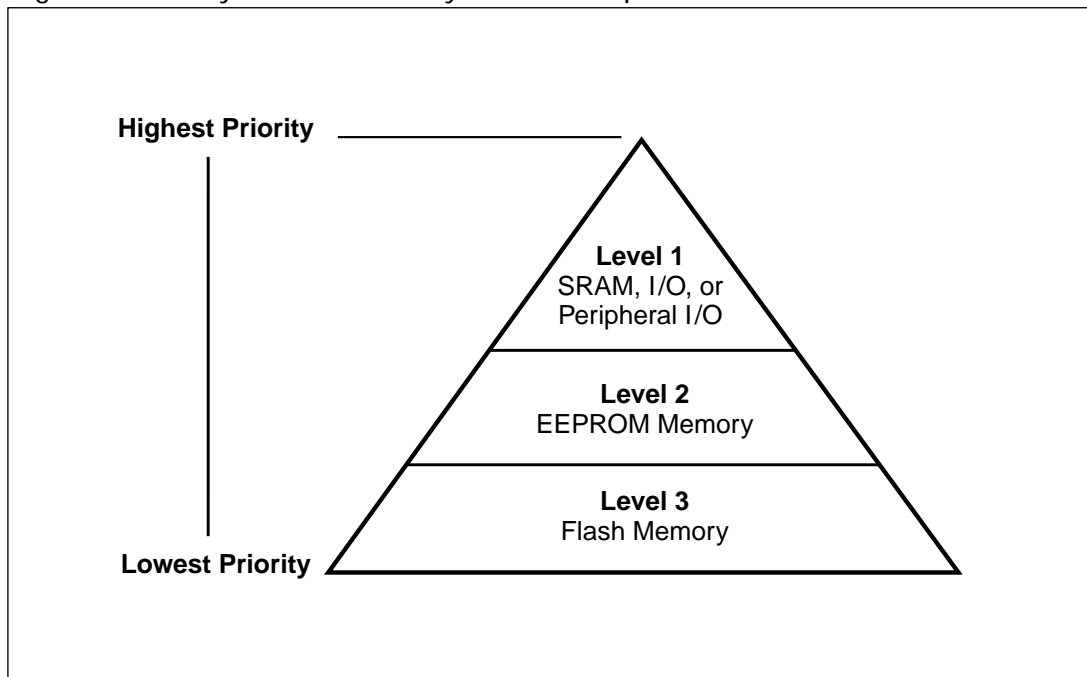
Example

FS0 is valid when the address is in the range of 8000h to BFFFh, EES0 is valid from 8000h to 9FFFh, and RS0 is valid from 8000h to 87FFh. Any address in the range of RS0 will always access the SRAM. Any address in the range of EES0 greater than 87FFh (and less than 9FFFh) will automatically address EEPROM memory segment 0. Any address greater than 9FFFh will access the Flash memory segment 0. You can see that half of the Flash memory segment 0 and one-fourth of EEPROM segment 0 can not be accessed in this example. Also note that an equation that defined FS1 to anywhere in the range of 8000h to BFFFh would **not** be valid.

Figure 7 shows the priority levels for all memory components. Any component on a higher level can overlap and has priority over any component on a lower level. Components on the same level must **not** overlap. Level one has the highest priority and level 3 has the lowest.

The PSD813F1 Functional Blocks (cont.)

Figure 7. Priority Level of Memory and I/O Components



9.1.3.1. Memory Select Configuration for MCUs with Separate Program and Data Spaces

The 8031 and compatible family of microcontrollers, which includes the 80C51, 80C151, 80C251, 80C51XA, and the C500 family, have separate address spaces for code memory (selected using PSEN) and data memory (selected using RD). Any of the memories within the PSD813F1 can reside in either space or both spaces. This is controlled through manipulation of the VM register that resides in the PSD’s CSIOP space.

The VM register is set using PSDsoft to have an initial value. It can subsequently be changed by the microcontroller so that memory mapping can be changed on-the-fly. For example, I may wish to have SRAM and Flash in Data Space at boot, and EEPROM in Program Space at boot, and later swap EEPROM and Flash. This is easily done with the VM register by using PSDsoft to configure it for boot up and having the microcontroller change it when desired.

Table 13 describes the VM Register.

Table 13. VM Register

| Bit 7 PIO_EN | Bit 6* | Bit 5* | Bit 4 FL_Data | Bit 3 EE_Data | Bit 2 FL_Code | Bit 1 EE_Code | Bit 0 SRAM_Code |
|----------------------|--------|--------|---------------------------|----------------------------|-----------------------------|------------------------------|----------------------------|
| 0 = disable PIO mode | * | * | 0 = RD can't access Flash | 0 = RD can't access EEPROM | 0 = PSEN can't access Flash | 0 = PSEN can't access EEPROM | 0 = PSEN can't access SRAM |
| 1 = enable PIO mode | * | * | 1 = RD access Flash | 1 = RD access EEPROM | 1 = PSEN access Flash | 1 = PSEN access EEPROM | 1 = PSEN access SRAM |

NOTE: Bits 6-5 are not used.

The PSD813F1 Functional Blocks (cont.)

9.1.3.2 Configuration Modes for MCUs with Separate Program and Data Spaces

9.1.3.2.1 Separate Space Modes

Code memory space is separated from data memory space. For example, the PSEN signal is used to access the program code from the Flash Memory, while the RD signal is used to access data from the EEPROM, SRAM and I/O Ports. This configuration requires the VM register to be set to 0Ch.

9.1.3.2.2 . Combined Space Modes

The program and data memory spaces are combined into one space that allows the main Flash Memory, EEPROM, and SRAM to be accessed by either PSEN or RD. For example, to configure the main Flash memory in combined space mode, bits 2 and 4 of the VM register are set to "1".

9.1.3.3 80C31 Memory Map Example

See Application Notes 57 and 64 for examples.

Figure 8. 8031 Memory Modes – Separate Space Mode

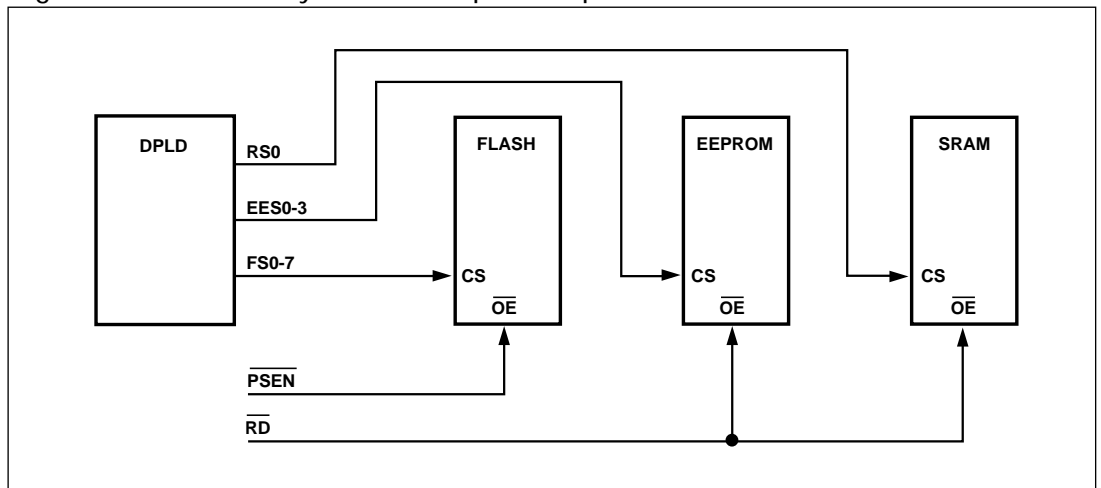
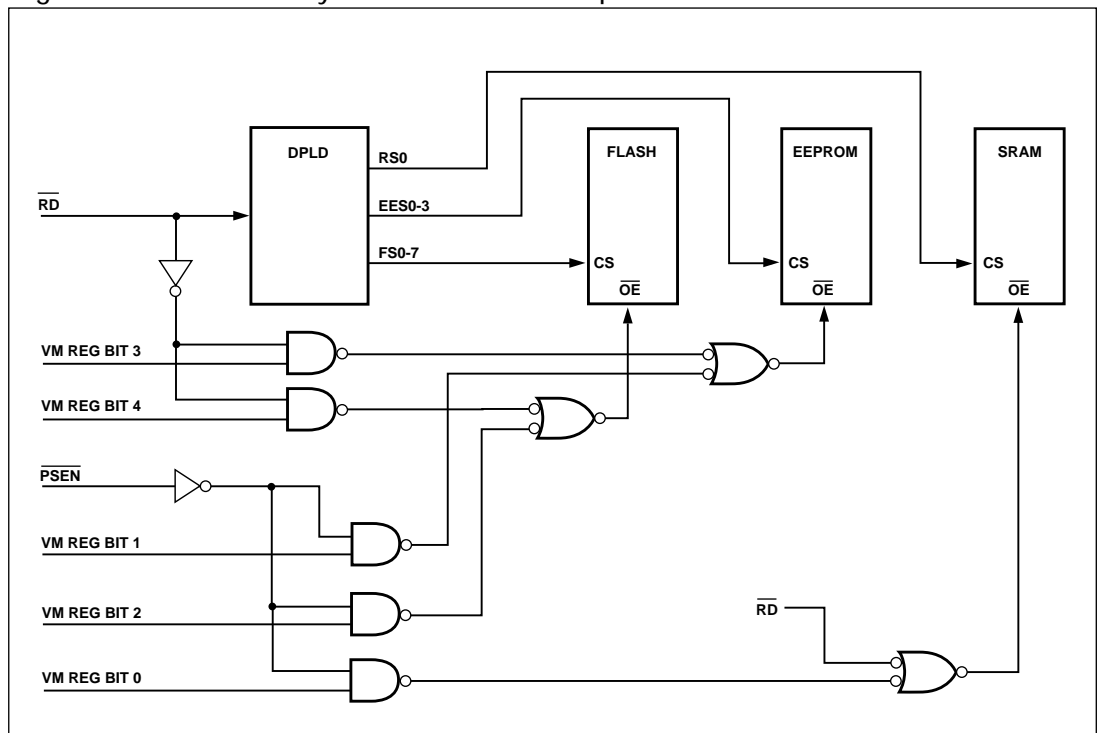


Figure 9. 80C31 Memory Mode – Combined Space Mode



The PSD813F1 Functional Blocks (cont.)

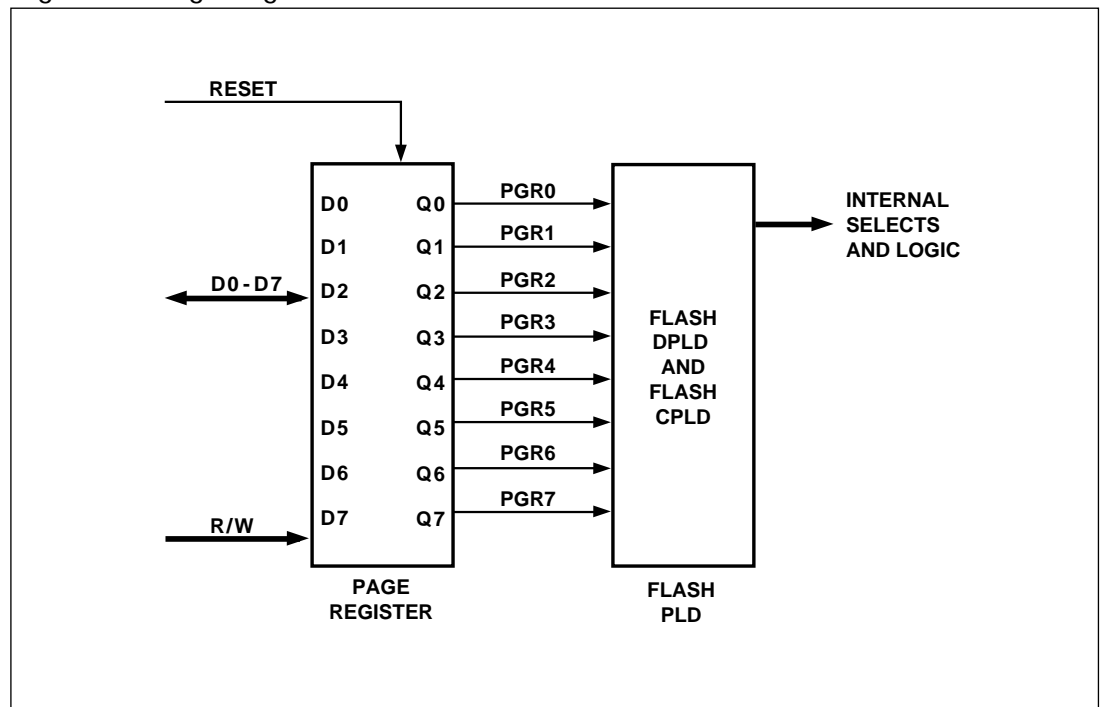
9.1.4 Page Register

The eight bit Page Register increases the addressing capability of the microcontroller by a factor of up to 256. The contents of the register can also be read by the microcontroller. The outputs of the Page Register (PGR0-PGR7) are inputs to the DPLD decoder and can be included in the Flash Memory, EEPROM, and SRAM chip select equations.

If memory paging is not needed, or if not all 8 page register bits are needed for memory paging, then these bits may be used in the CPLD for general logic. See Application Note 57.

Figure 10 shows the Page Register. The eight flip flops in the register are connected to the internal data bus D0-D7. The microcontroller can write to or read from the Page Register. The Page Register can be accessed at address location CS1OP + E0h.

Figure 10. Page Register



The PSD813F1 Functional Blocks (cont.)

9.2 PLDs

The PLDs bring programmable logic functionality to the PSD813F1. After specifying the logic for the PLDs using the PSDabel tool in PSDsoft, the logic is programmed into the device and available upon power-up.

The PSD813F1 contains two PLDs: the Decode PLD (DPLD), and the Complex PLD (CPLD). The PLDs are briefly discussed in the next few paragraphs, and in more detail in sections 9.2.1 and 9.2.2. Figure 11 shows the configuration of the PLDs.

The DPLD performs address decoding for internal and external components, such as memory, registers, and I/O port selects.

The CPLD can be used for logic functions, such as loadable counters and shift registers, state machines, and encoding and decoding logic. These logic functions can be constructed using the 16 Output Micro↔Cells (OMCs), 24 Input Micro↔Cells (IMCs), and the AND array. The CPLD can also be used to generate external chip selects.

The AND array is used to form product terms. These product terms are specified using PSDabel. An Input Bus consisting of 73 signals is connected to the PLDs. The signals are shown in Table 15.

Table 15. DPLD and CPLD Inputs

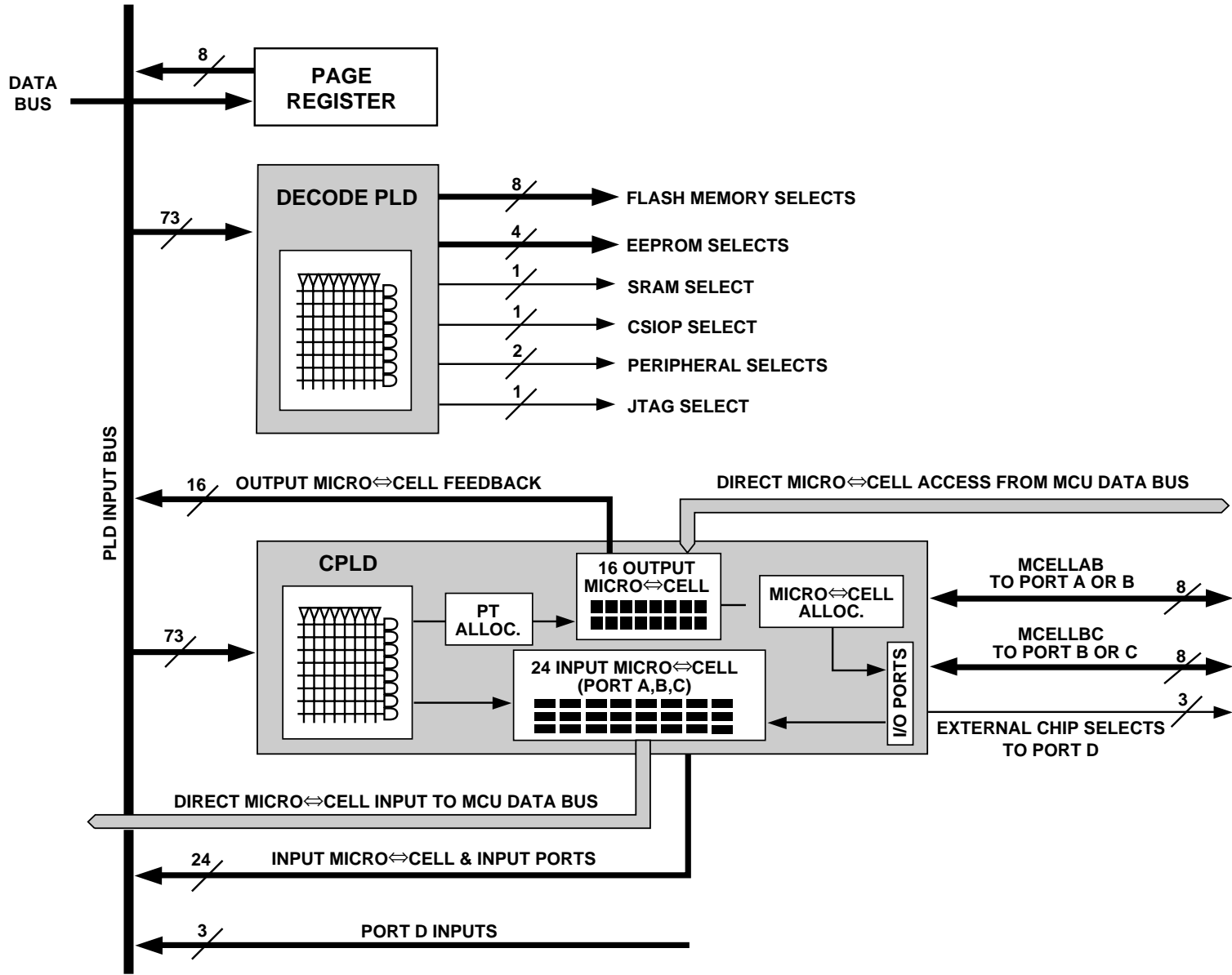
| Input Source | Input Name | Number of Signals |
|-------------------------------|-----------------|-------------------|
| MCU Address Bus | A[15:0]* | 16 |
| MCU Control Signals | CNTL[2:0] | 3 |
| Reset | RST | 1 |
| Power Down | PDN | 1 |
| Port A Input Micro↔Cells | PA[7-0] | 8 |
| Port B Input Micro↔Cells | PB[7-0] | 8 |
| Port C Input Micro↔Cells | PC[7-0] | 8 |
| Port D Inputs | PD[2:0] | 3 |
| Page Register | PGR(7:0) | 8 |
| Micro↔Cell AB Feedback | MCELLAB.FB[7:0] | 8 |
| Micro↔Cell BC Feedback | MCELLBC.FB[7:0] | 8 |
| EEPROM Programming Status Bit | Rdy/Bsy | 1 |

NOTE: The address inputs are A[19:4] in 80C51XA mode.

The Turbo Bit in PSD813F1

The PLDs in the PSD813F1 can minimize power consumption by switching off when inputs remain unchanged for an extended time of about 70 ns. Setting the Turbo mode bit to off (Bit 3 of the PMMR0 register) automatically places the PLDs into standby if no inputs are changing. Turbo-off mode increases propagation delays while reducing power consumption. Refer to the Power Management Unit section on how to set the Turbo Bit. Additionally, five bits are available in the PMMR2 register to block MCU control signals from entering the PLDs. This reduces power consumption and can be used only when these MCU control signals are not used in PLD logic equations.

Figure 11. PLD Block Diagram



The PSD813F1 Functional Blocks (cont.)

Each of the two PLDs has unique characteristics suited for its applications They are described in the following sections.

9.2.1 Decode PLD (DPLD)

The DPLD, shown in Figure 12, is used for decoding the address for internal and external components. The DPLD can generate the following decode signals:

- 8 sector selects for the main Flash memory (three product terms each)
- 4 sector selects for the EEPROM memory (three product terms each)
- 1 internal SRAM select signal (two product terms)
- 1 internal CSIOP (PSD configuration register) select signal
- 1 JTAG select signal (enables JTAG on Port C)
- 2 internal peripheral select signals (peripheral I/O mode).

9.2.2 Complex PLD (CPLD)

The CPLD can be used to implement system logic functions, such as loadable counters and shift registers, system mailboxes, handshaking protocols, state machines, and random logic. The CPLD can also be used to generate 3 external chip selects, routed to Port D. Although external chip selects can be produced by any Output Micro↔Cell, these three external chip selects on Port D do not consume any Output Micro↔Cells.

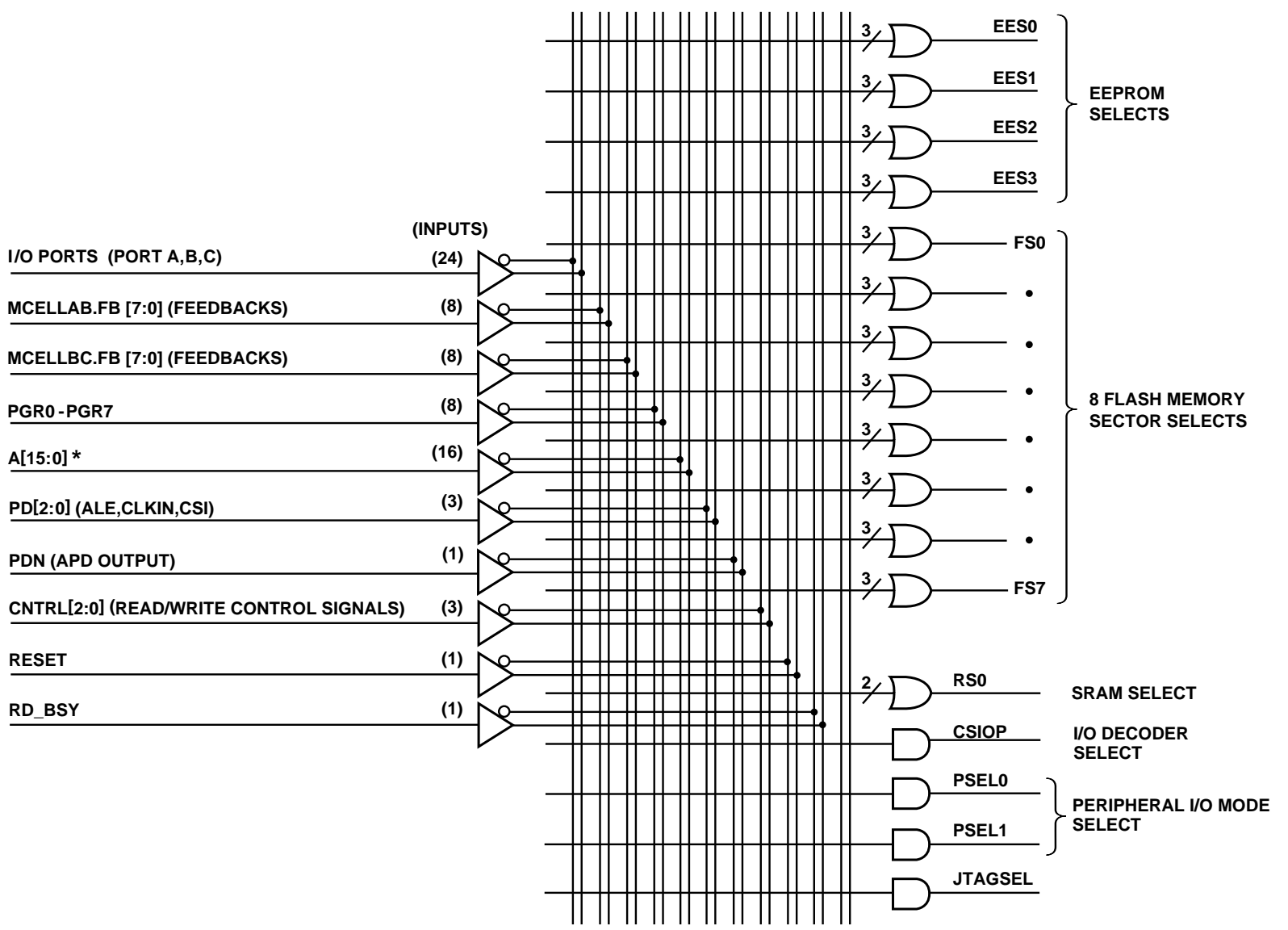
As shown in Figure 11, the CPLD has the following blocks:

- 24 Input Micro↔Cells (IMCs)
- 16 Output Micro↔Cells (OMCs)
- Micro↔Cell Allocator
- Product Term Allocator
- AND array capable of generating up to 137 product terms
- Four I/O ports.

Each of the blocks are described in the subsections that follow.

The Input and Output Micro↔Cells are connected to the PSD813F1 internal data bus and can be directly accessed by the microcontroller. This enables the MCU software to load data into the Output Micro↔Cells or read data from both the Input and Output Micro↔Cells. This feature allows efficient implementation of system logic and eliminates the need to connect the data bus to the AND logic array as required in most standard PLD macrocell architectures.

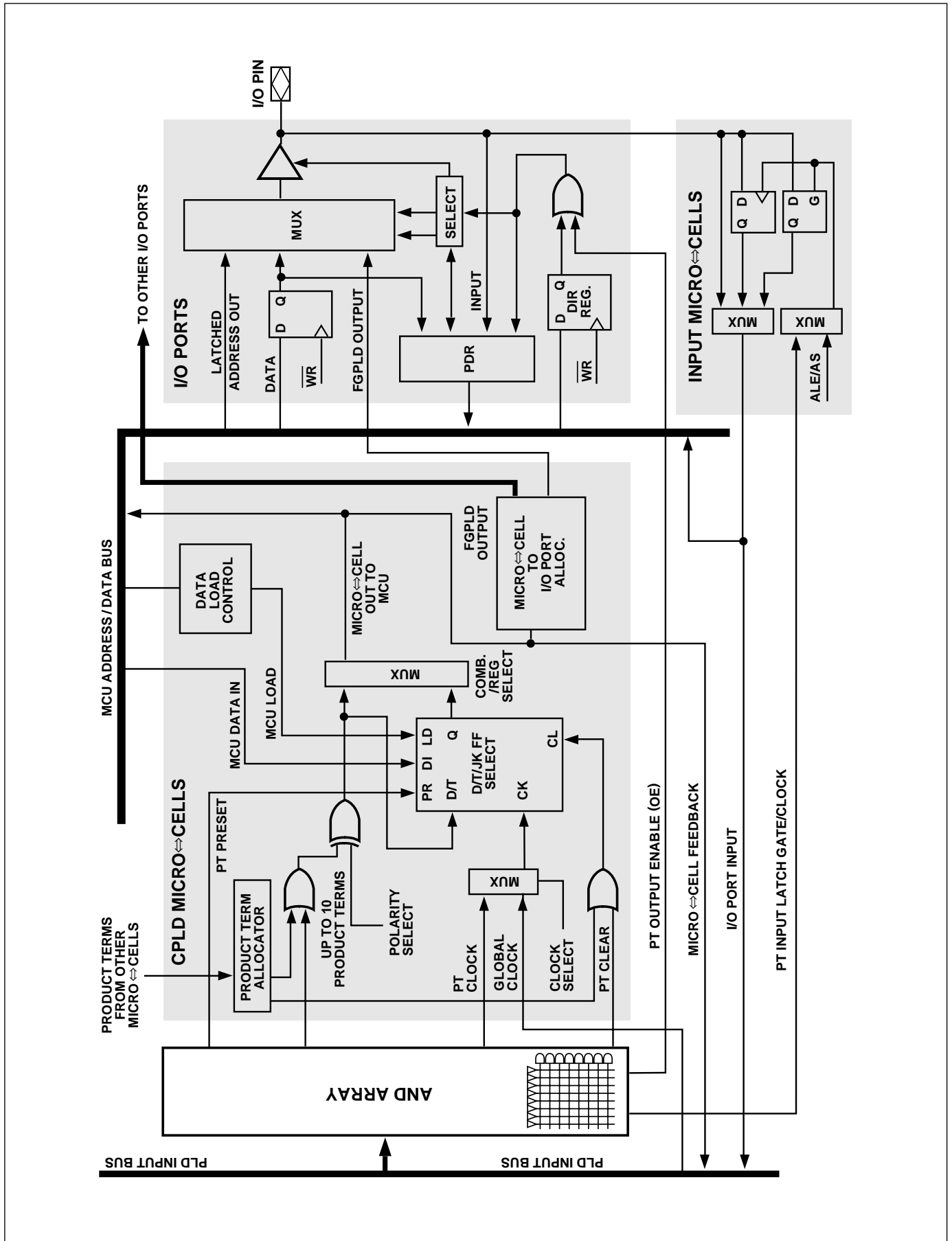
Figure 12. DPLD Logic Array



*NOTE: The address inputs are A[19:4] in 80C51XA mode.



Figure 13. The Micro↔Cell and I/O Port



The
PSD813F1
Functional
Blocks
(cont.)

9.2.2.1 Output Micro \leftrightarrow Cell

Eight of the Output Micro \leftrightarrow Cells are connected to Ports A and B pins and are named as McellAB0-7. The other eight Micro \leftrightarrow Cells are connected to Ports B and C pins and are named as McellBC0-7. If an McellAB output is not assigned to a specific pin in PSDlabel, the Micro \leftrightarrow Cell Allocator will assign it to either Port A or B. The same is true for a McellBC output on Port B or C. Table 16 shows the Micro \leftrightarrow Cells and Port assignment.

Table 16. Output Micro \leftrightarrow Cell Port and Data Bit Assignments

| Output Micro \leftrightarrow Cell | Port Assignment | Native Product Terms | Maximum Borrowed Product Terms | Data Bit for Loading or Reading |
|-------------------------------------|-----------------|----------------------|--------------------------------|---------------------------------|
| McellAB0 | Port A0, B0 | 3 | 6 | D0 |
| McellAB1 | Port A1, B1 | 3 | 6 | D1 |
| McellAB2 | Port A2, B2 | 3 | 6 | D2 |
| McellAB3 | Port A3, B3 | 3 | 6 | D3 |
| McellAB4 | Port A4, B4 | 3 | 6 | D4 |
| McellAB5 | Port A5, B5 | 3 | 6 | D5 |
| McellAB6 | Port A6, B6 | 3 | 6 | D6 |
| McellAB7 | Port A7, B7 | 3 | 6 | D7 |
| McellBC0 | Port B0, C0 | 4 | 5 | D0 |
| McellBC1 | Port B1, C1 | 4 | 5 | D1 |
| McellBC2 | Port B2, C2 | 4 | 5 | D2 |
| McellBC3 | Port B3, C3 | 4 | 5 | D3 |
| McellBC4 | Port B4, C4 | 4 | 6 | D4 |
| McellBC5 | Port B5, C5 | 4 | 6 | D5 |
| McellBC6 | Port B6, C6 | 4 | 6 | D6 |
| McellBC7 | Port B7, C7 | 4 | 6 | D7 |

The Output Micro \leftrightarrow Cell (OMC) architecture is shown in Figure 14. As shown in the figure, there are native product terms available from the AND array, and borrowed product terms available (if unused) from other OMCs. The polarity of the product term is controlled by the XOR gate. The OMC can implement either sequential logic, using the flip-flop element, or combinatorial logic. The multiplexer selects between the sequential or combinatorial logic outputs. The multiplexer output can drive a Port pin and has a feedback path to the AND array inputs.

The flip-flop in the OMC can be configured as a D, T, JK, or SR type in the PSDlabel program. The flip-flop's clock, preset, and clear inputs may be driven from a product term of the AND array. Alternatively, the external CLKIN signal can be used for the clock input to the flip-flop. The flip-flop is clocked on the rising edge of the clock input. The preset and clear are active-high inputs. Each clear input can use up to two product terms.

The PSD813F1 Functional Blocks (cont.)

9.2.2.2 The Product Term Allocator

The CPLD has a Product Term Allocator. The PSDabel compiler uses the Allocator to borrow and place product terms from one Micro \leftrightarrow Cell to another. The following list summarizes how product terms are allocated:

- McellAB0-7 all have three native product terms and may borrow up to six more
- McellBC0-3 all have four native product terms and may borrow up to five more
- McellBC4-7 all have four native product terms and may borrow up to six more.

Each Micro \leftrightarrow Cell may only borrow product terms from certain other Micro \leftrightarrow Cells. Product terms already in use by one Micro \leftrightarrow Cell will not be available for a different Micro \leftrightarrow Cell.

If an equation requires more product terms than what is available to it, then “external” product terms will be required, which will consume other OMCs. If external product terms are used, extra delay will be added for the equation that required the extra product terms. This is called product term expansion. PSDsoft will perform this expansion as needed.

9.2.2.3 Loading and Reading the Output Micro \leftrightarrow Cells (OMCs)

The OMCs occupy a memory location in the MCU address space, as defined by the CSIOP (refer to the I/O section). The flip-flops in each of the 16 OMCs can be loaded from the data bus by a microcontroller. Loading the OMCs with data from the MCU takes priority over internal functions. As such, the preset, clear, and clock inputs to the flip-flop can be overridden by the MCU. The ability to load the flip-flops and read them back is useful in such applications as loadable counters and shift registers, mailboxes, and handshaking protocols.

Data can be loaded to the OMCs on the trailing edge of the WR signal (edge loading) or during the time that the WR signal is active (level loading). The method of loading is specified in PSDsoft Configuration.

9.2.2.4 The OMC Mask Register

There is one Mask Register for each of the two groups of eight OMCs. The Mask Registers can be used to block the loading of data to individual OMCs. The default value for the Mask Registers is 00h, which allows loading of the OMCs. When a given bit in a Mask Register is set to a ‘1’, the MCU will be blocked from writing to the associated OMC. For example, suppose McellAB0-3 are being used for a state machine. You would not want a MCU write to McellAB to overwrite the state machine registers. Therefore, you would want to load the Mask Register for McellAB (Mask Micro \leftrightarrow Cell AB) with the value 0Fh.

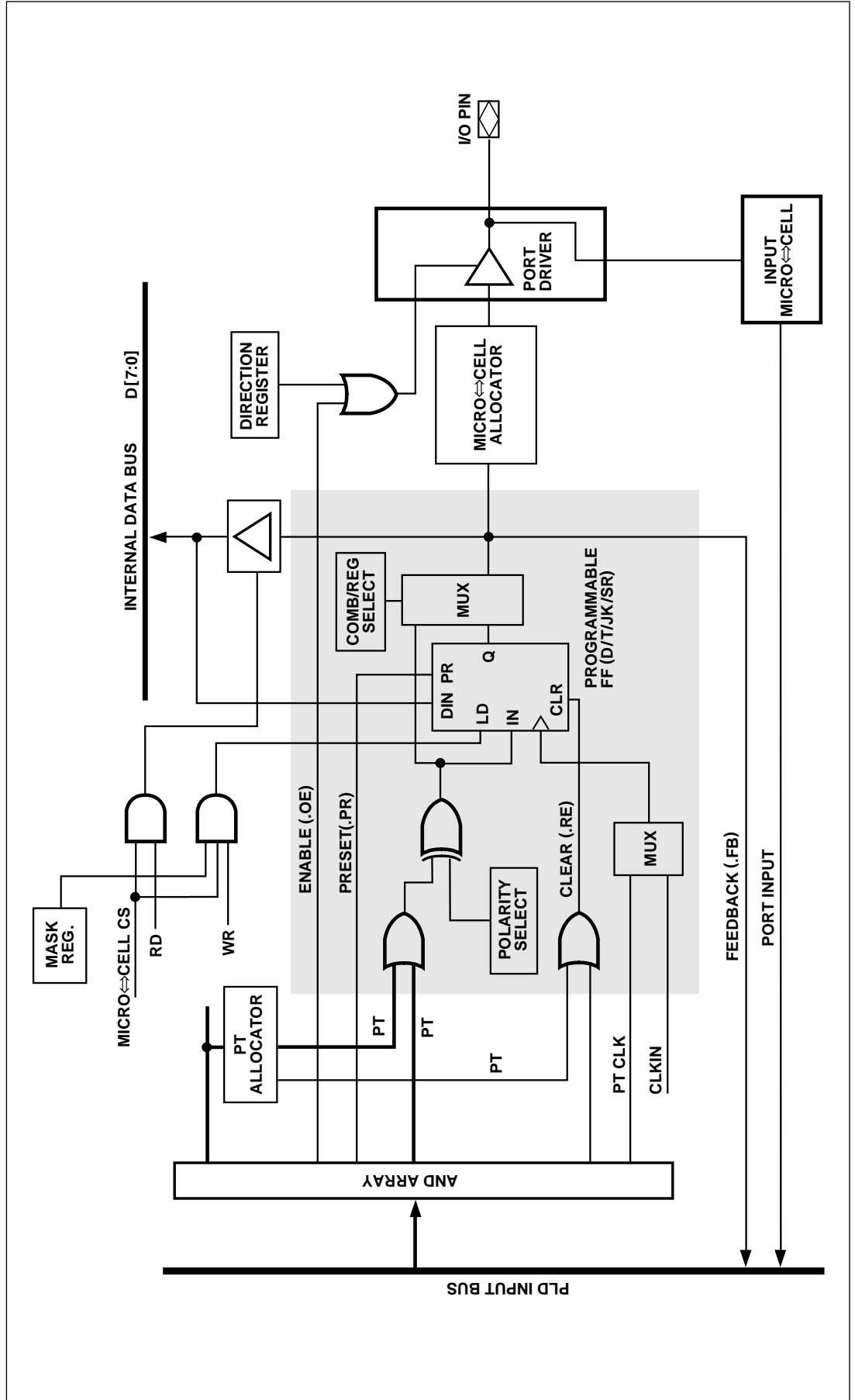
9.2.2.5 The Output Enable of the OMC

The OMC can be connected to an I/O port pin as a PLD output. The output enable of each Port pin driver is controlled by a single product term from the AND array, ORed with the Direction Register output. The pin is enabled upon power up if no output enable equation is defined and if the pin is declared as a PLD output in PSDsoft.

If the OMC output is declared as an internal node and not as a Port pin output in the PSDabel file, then the Port pin can be used for other I/O functions. The internal node feedback can be routed as an input to the AND array.

The PSD813F1 Functional Blocks (cont.)

Figure 14. CPLD Output MicroCell



The
PSD813F1
Functional
Blocks
(cont.)

9.2.2.6 Input Micro↔Cells (IMCs)

The CPLD has 24 IMCs, one for each pin on Ports A, B, and C. The architecture of the IMC is shown in Figure 15. The IMCs are individually configurable, and can be used as a latch, register, or to pass incoming Port signals prior to driving them onto the PLD input bus. The outputs of the IMCs can be read by the microcontroller through the internal data bus.

The enable for the latch and clock for the register are driven by a multiplexer whose inputs are a product term from the CPLD AND array or the MCU address strobe (ALE/AS). Each product term output is used to latch or clock four IMCs. Port inputs 3-0 can be controlled by one product term and 7-4 by another.

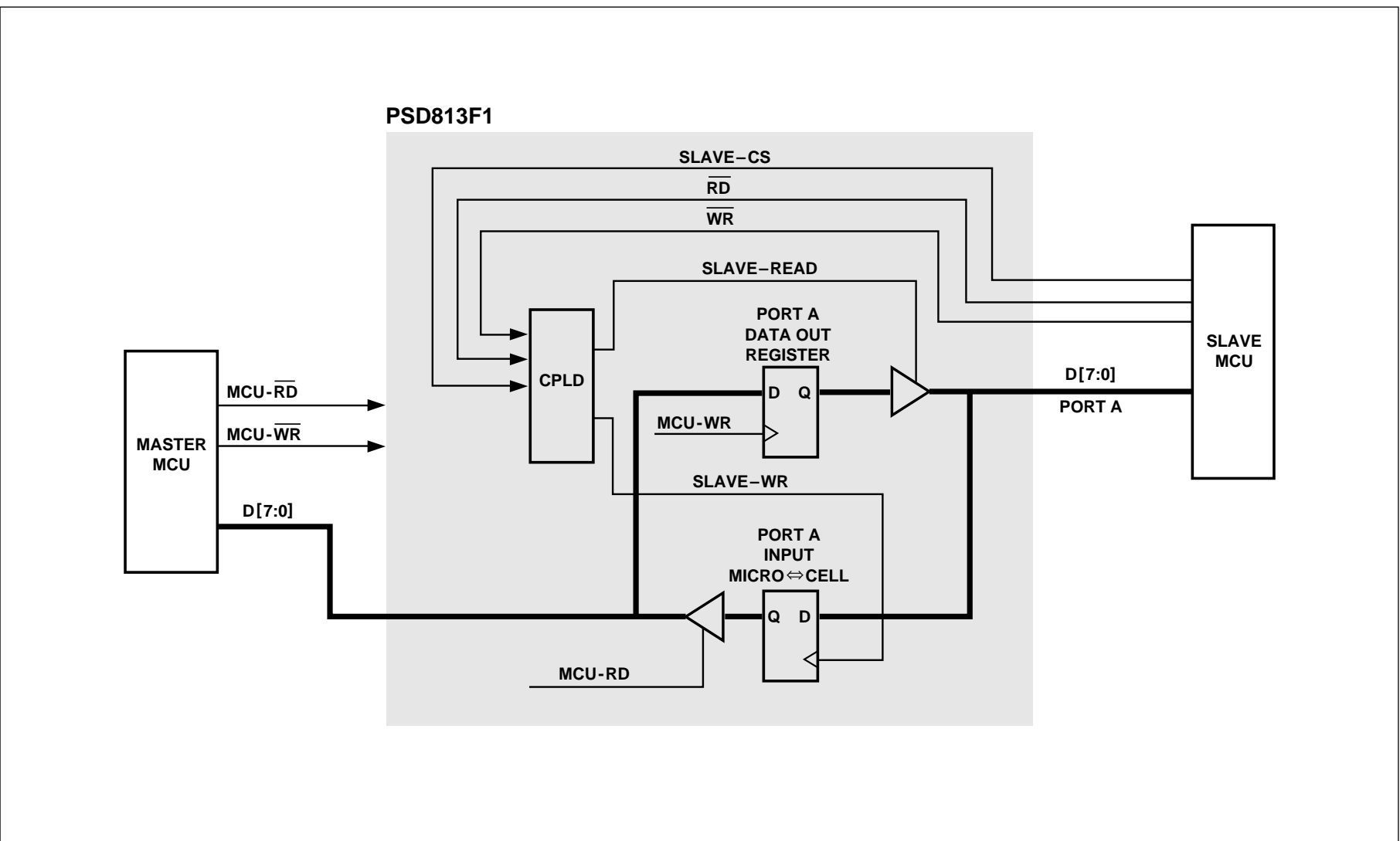
Configurations for the IMCs are specified by equations written in PSDLabel (see Application Note 55). Outputs of the IMCs can be read by the MCU via the IMC buffer. See the I/O Port section on how to read the IMCs.

IMCs can use the address strobe to latch address bits higher than A15. Any latched addresses are routed to the PLDs as inputs.

IMCs are particularly useful with handshaking communication applications where two processors pass data back and forth through a common mailbox. Figure 16 shows a typical configuration where the Master MCU writes to the Port A Data Out Register. This, in turn, can be read by the Slave MCU via the activation of the "Slave-Read" output enable product term. The Slave can also write to the Port A IMCs and the Master can then read the IMCs directly. Note that the "Slave-Read" and "Slave-Wr" signals are product terms that are derived from the Slave MCU inputs RD, WR, and Slave_CS.

The
PSD813F1
Functional
Blocks
(cont.)

Figure 16. Handshaking Communication Using Input Micro⇌Cells



The
PSD813F1
Functional
Blocks
(cont.)

9.3 Microcontroller Bus Interface

The “no-glue logic” PSD813F1 Microcontroller Bus Interface can be directly connected to most popular microcontrollers and their control signals. Key 8-bit microcontrollers with their bus types and control signals are shown in Table 17. The interface type is specified using the PSDsoft Configuration.

Table 17. Microcontrollers and their Control Signals

| MCU | Data Bus Width | CNTL0 | CNTL1 | CNTL2 | PC7 | PD0** | ADIO0 | PA3-PA0 | PA7-PA3 |
|----------|----------------|-------------------|-------------------|-------------------|------------------|-----------|-------|---------|---------|
| 8031 | 8 | \overline{WR} | \overline{RD} | \overline{PSEN} | * | ALE | A0 | * | * |
| 80C51XA | 8 | \overline{WR} | \overline{RD} | \overline{PSEN} | * | ALE | A4 | A3-A0 | * |
| 80C251 | 8 | \overline{WR} | \overline{PSEN} | * | * | ALE | A0 | * | * |
| 80C251 | 8 | \overline{WR} | \overline{RD} | \overline{PSEN} | * | ALE | A0 | * | * |
| 80198 | 8 | \overline{WR} | \overline{RD} | * | * | ALE | A0 | * | * |
| 68HC11 | 8 | R/ \overline{W} | E | * | * | AS | A0 | * | * |
| 68HC912 | 8 | R/ \overline{W} | E | * | \overline{DBE} | AS | A0 | * | * |
| Z80 | 8 | \overline{WR} | \overline{RD} | * | * | * | A0 | D3-D0 | D7-D4 |
| Z8 | 8 | R/ \overline{W} | \overline{DS} | * | * | AS | A0 | * | * |
| 68330 | 8 | R/ \overline{W} | \overline{DS} | * | * | <u>AS</u> | A0 | * | * |
| M37702M2 | 8 | R/ \overline{W} | \overline{E} | * | * | ALE | A0 | D3-D0 | D7-D4 |

*Unused CNTL2 pin can be configured as CPLD input. Other unused pins (PC7, PD0, PA3-0) can be configured for other I/O functions.

**ALE/AS input is optional for microcontrollers with a non-multiplexed bus

9.3.1. PSD813F1 Interface to a Multiplexed 8-Bit Bus

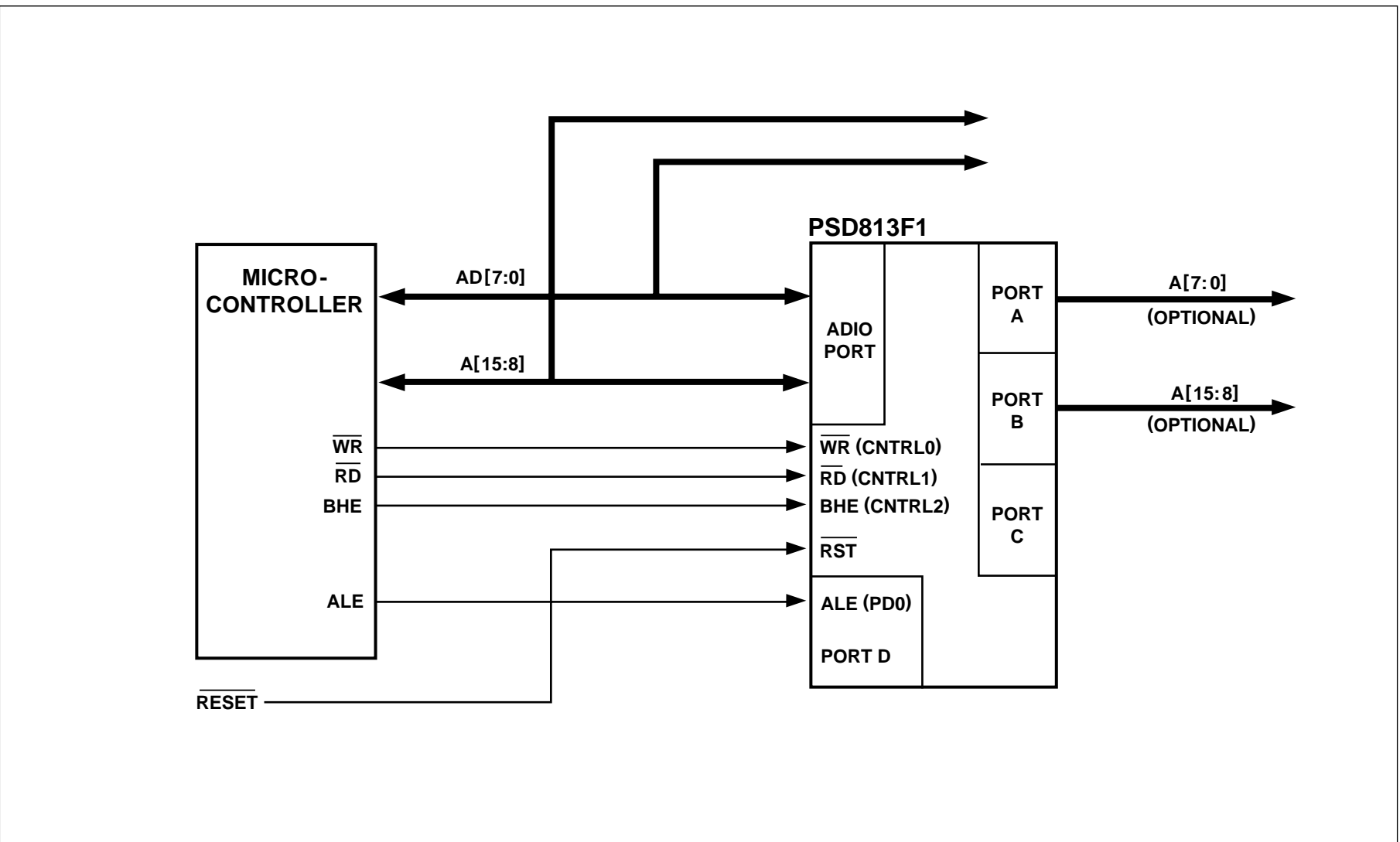
Figure 17 shows an example of a system using a microcontroller with an 8-bit multiplexed bus and a PSD813F1. The ADIO port on the PSD813F1 is connected directly to the microcontroller address/data bus. ALE latches the address lines internally. Latched addresses can be brought out to Port A or B. The PSD813F1 drives the ADIO data bus only when one of its internal resources is accessed and the RD input is active. Should the system address bus exceed sixteen bits, Ports A, B, C, or D may be used as additional address inputs.

9.3.2. PSD813F1 Interface to a Non-Multiplexed 8-Bit Bus

Figure 18 shows an example of a system using a microcontroller with an 8-bit non-multiplexed bus and a PSD813F1. The address bus is connected to the ADIO Port, and the data bus is connected to Port A. Port A is in tri-state mode when the PSD813F1 is not accessed by the microcontroller. Should the system address bus exceed sixteen bits, Ports B, C, or D may be used for additional address inputs.

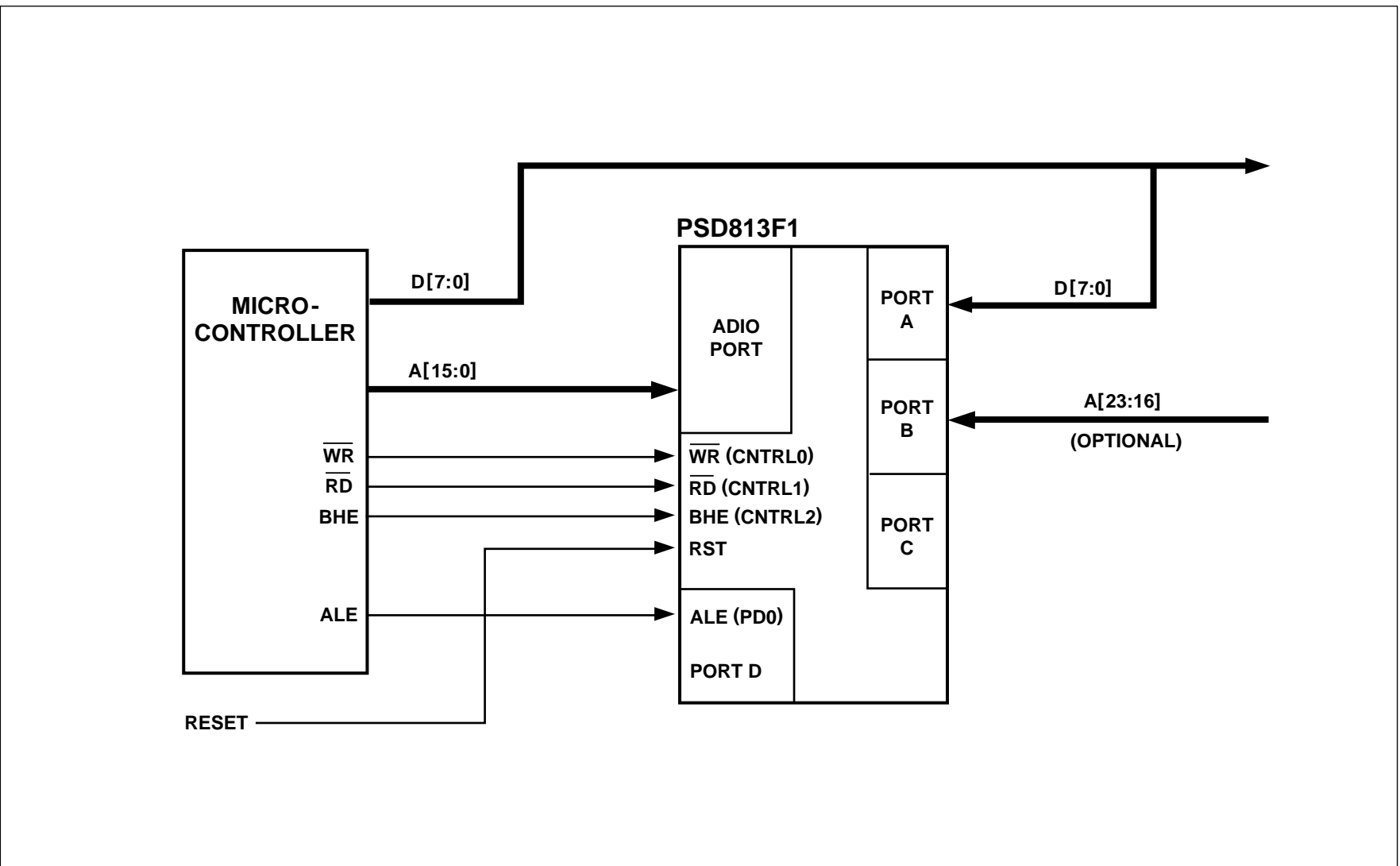
The
PSD813F1
Functional
Blocks
(cont.)

Figure 17. An Example of a Typical 8-Bit Multiplexed Bus Interface



The
PSD813F1
Functional
Blocks
(cont.)

Figure 18. An Example of a Typical 8-Bit Non-Multiplexed Bus Interface



The
PSD813F1
Functional
Blocks
(cont.)

9.3.3 Data Byte Enable Reference

Microcontrollers have different data byte orientations. The following table shows how the PSD813F1 interprets byte/word operations in different bus write configurations. Even-byte refers to locations with address A0 equal to zero and odd byte as locations with A0 equal to one.

Table 18. Eight-Bit Data Bus

| BHE | A0 | D7-D0 |
|-----|----|-----------|
| X | 0 | Even Byte |
| X | 1 | Odd Byte |

9.3.4 Microcontroller Interface Examples

Figures 19 through 23 show examples of the basic connections between the PSD813F1 and some popular microcontrollers. The PSD813F1 Control input pins are labeled as to the microcontroller function for which they are configured. The MCU interface is specified using the PSDsoft Configuration.

9.3.4.1 80C31

Figure 19 shows the interface to the 80C31, which has an 8-bit multiplexed address/data bus. The lower address byte is multiplexed with the data bus. The microcontroller control signals PSEN, RD, and WR may be used for accessing the internal memory components and I/O Ports. The ALE input (pin PD0) latches the address.

9.3.4.2 80C251

The Intel 80C251 microcontroller features a user-configurable bus interface with four possible bus configurations, as shown in Table 19.

Configuration 1 is 80C31 compatible, and the bus interface to the PSD813F1 is identical to that shown in Figure 19. Configurations 2 and 3 have the same bus connection as shown in Figure 20. There is only one read input (PSEN) connected to the Cntl1 pin on the PSD813F1. The A16 connection to the PA0 pin allows for a larger address input to the PSD813F1. Configuration 4 is shown in Figure 21. The RD signal is connected to Cntl1 and the PSEN signal is connected to the CNTL2.

The 80C251 has two major operating modes: Page Mode and Non-Page Mode. In Non-Page Mode, the data is multiplexed with the lower address byte, and ALE is active in every bus cycle. In Page Mode, data D[7:0] is multiplexed with address A[15:8]. In a bus cycle where there is a Page hit, the ALE signal is not active and only addresses A[7:0] are changing. The PSD813F1 supports both modes. In Page Mode, the PSD bus timing is identical to Non-Page Mode except the address hold time and setup time with respect to ALE is not required. The PSD access time is measured from address A[7:0] valid to data in valid.

The
PSD813F1
Functional
Blocks
(cont.)

Table 19. 80C251 Configurations

| Configuration | 80C251 Read/Write Pins | Connecting to PSD813F1 Pins | Page Mode |
|---------------|---|-----------------------------------|---|
| 1 | \overline{WR} \overline{RD} \overline{PSEN} | CNTL0 CNTL1 CNTL2 | Non-Page Mode, 80C31 compatible A[7:0] multiplex with D[7:0] |
| 2 | \overline{WR} \overline{PSEN} only | CNTL0 CNTL1 | Non-Page Mode A[7:0] multiplex with D[7:0] |
| 3 | \overline{WR} \overline{PSEN} only | CNTL0 CNTL1 | Page Mode A[15:8] multiplex with D[7:0] |
| 4 | \overline{WR} \overline{RD} \overline{PSEN} | CNTL0 CNTL1 CNTL2 | Page Mode A[15:8] multiplex with D[7:0] |

9.3.4.3 80C51XA

The Philips 80C51XA microcontroller family supports an 8- or 16-bit multiplexed bus that can have burst cycles. Address bits A[3:0] are not multiplexed, while A[19:4] are multiplexed with data bits D[15:0] in 16-bit mode. In 8-bit mode, A[11:4] are multiplexed with data bits D[7:0].

The 80C51XA can be configured to operate in eight-bit data mode. (shown in Figure 22). The 80C51XA improves bus throughput and performance by executing Burst cycles for code fetches. In Burst Mode, address A19-4 are latched internally by the PSD813F1, while the 80C51XA changes the A3-0 lines to fetch up to 16 bytes of code. The PSD access time is then measured from address A3-A0 valid to data in valid. The PSD bus timing requirement in Burst Mode is identical to the normal bus cycle, except the address setup and hold time with respect to ALE does not apply.

9.3.4.4 68HC11

Figure 23 shows an interface to a 68HC11 where the PSD813F1 is configured in 8-bit multiplexed mode with \overline{E} and R/W settings. The DPLD can generate the READ and WR signals for external devices.

Figure 19. Interfacing the PSD813F1 with an 80C31

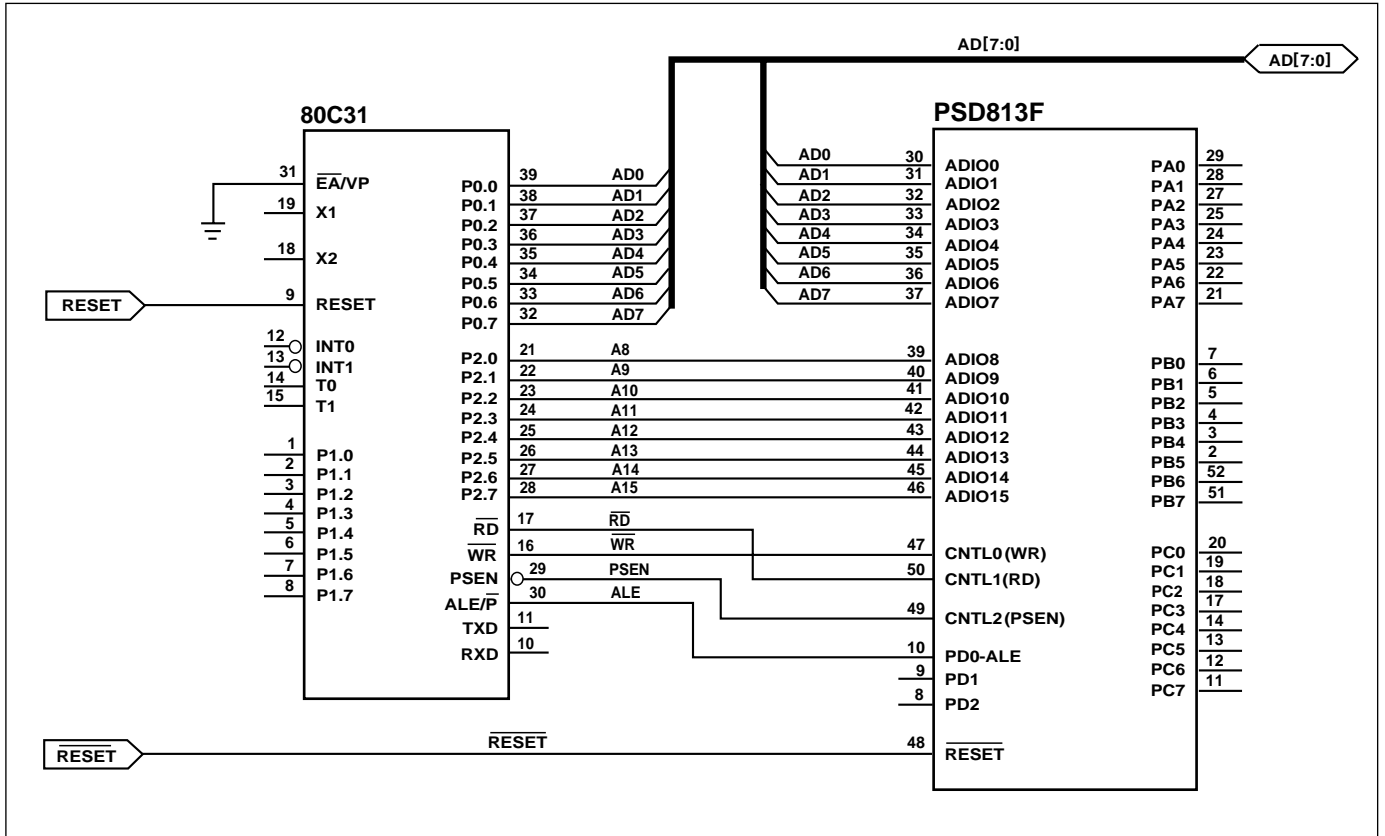


Figure 20. Interfacing the PSD813F1 to the 80C251, with One Read Input

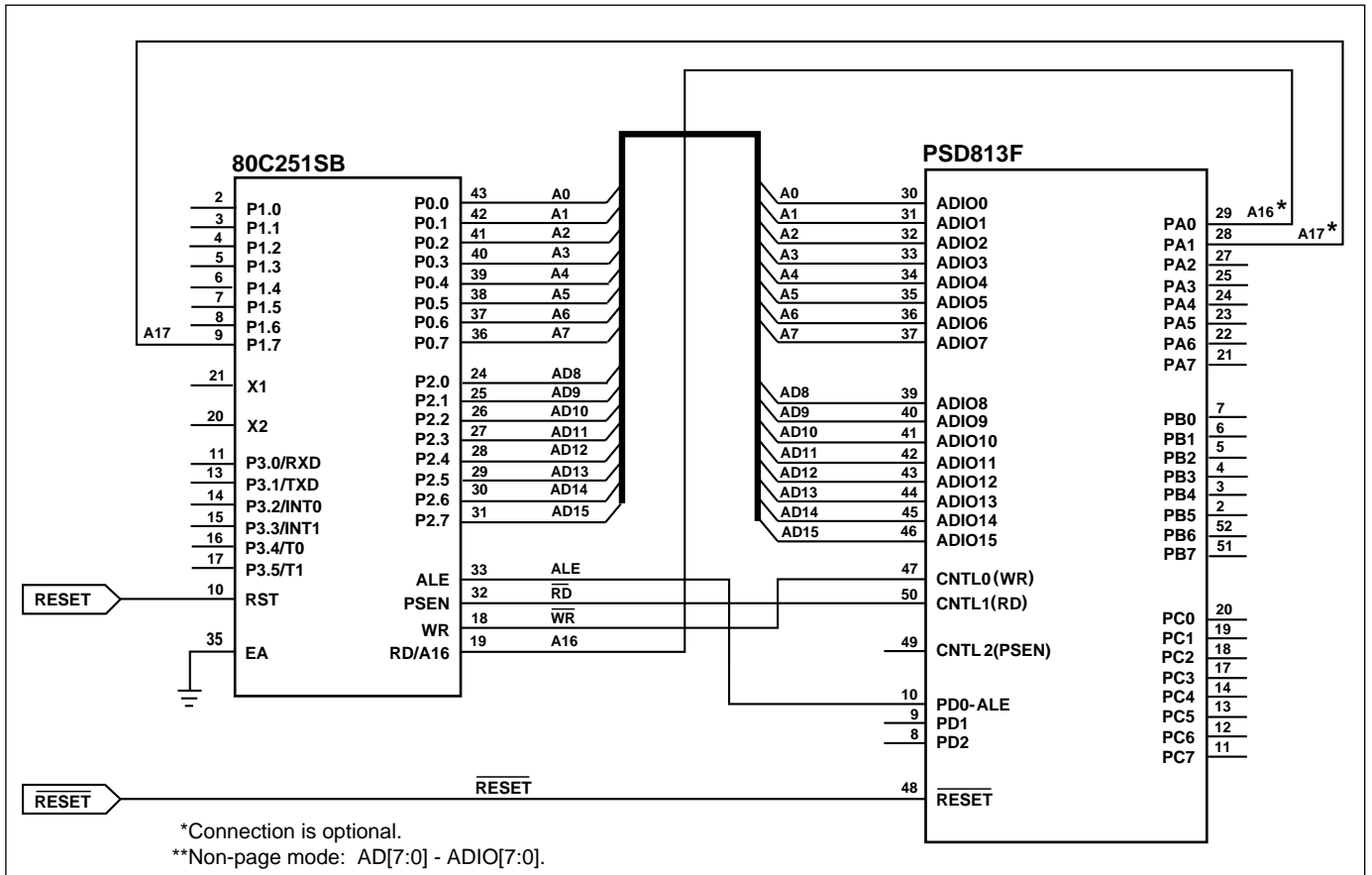


Figure 21. Interfacing the PSD813F1 to the 80C251, with Read and PSEN Inputs

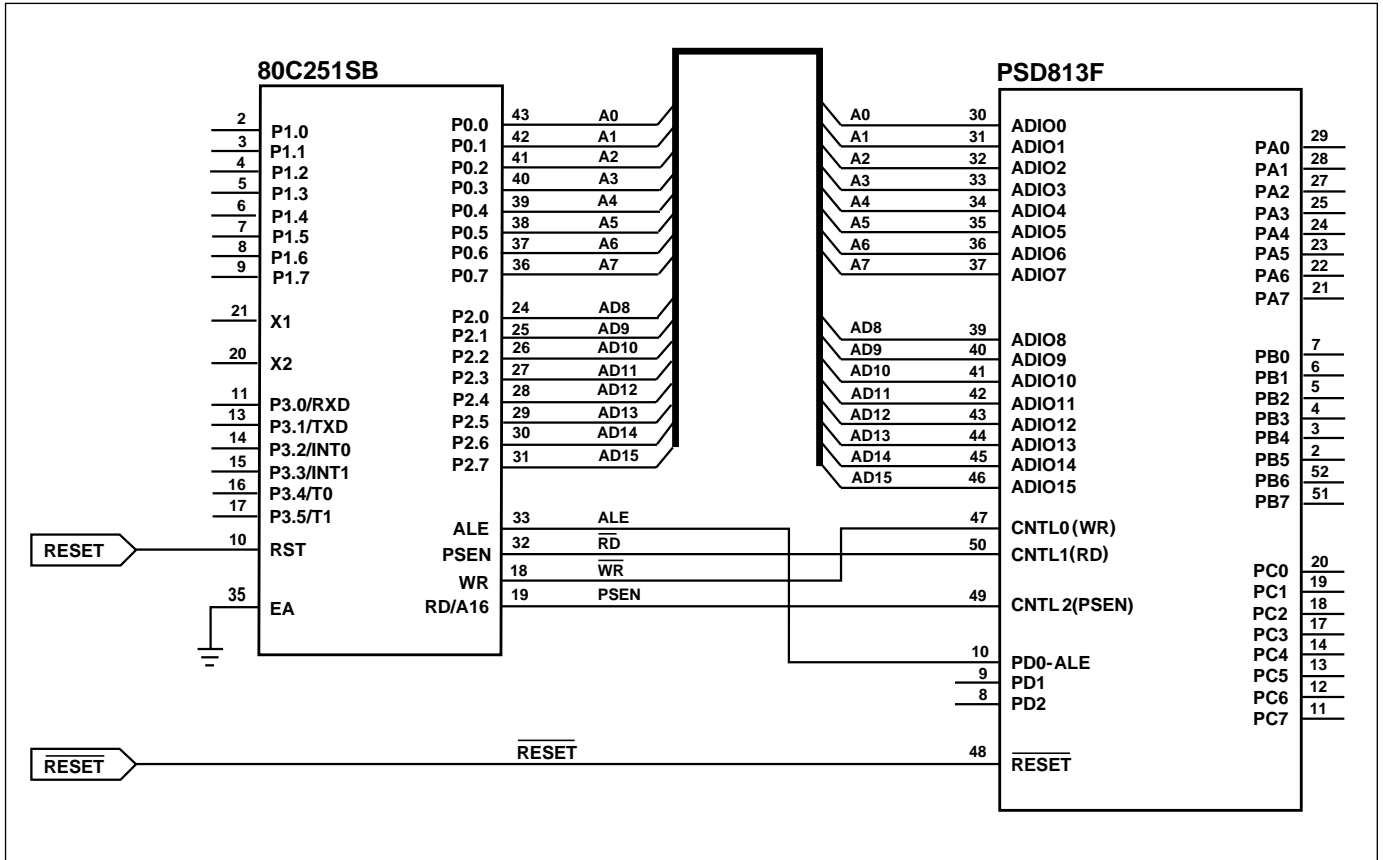


Figure 22. Interfacing the PSD813F1 to the 80C51XA, 8-Bit Data Bus

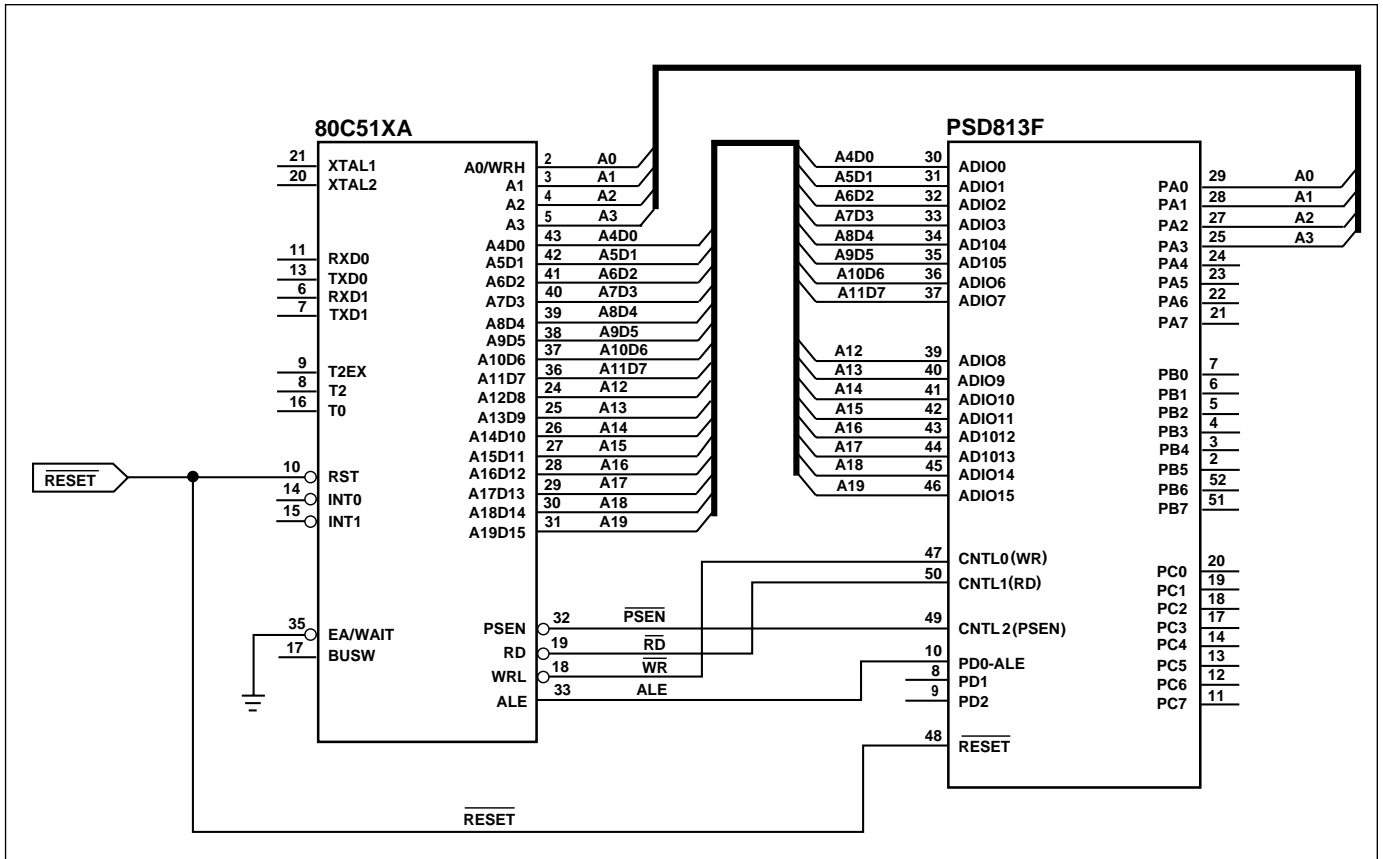
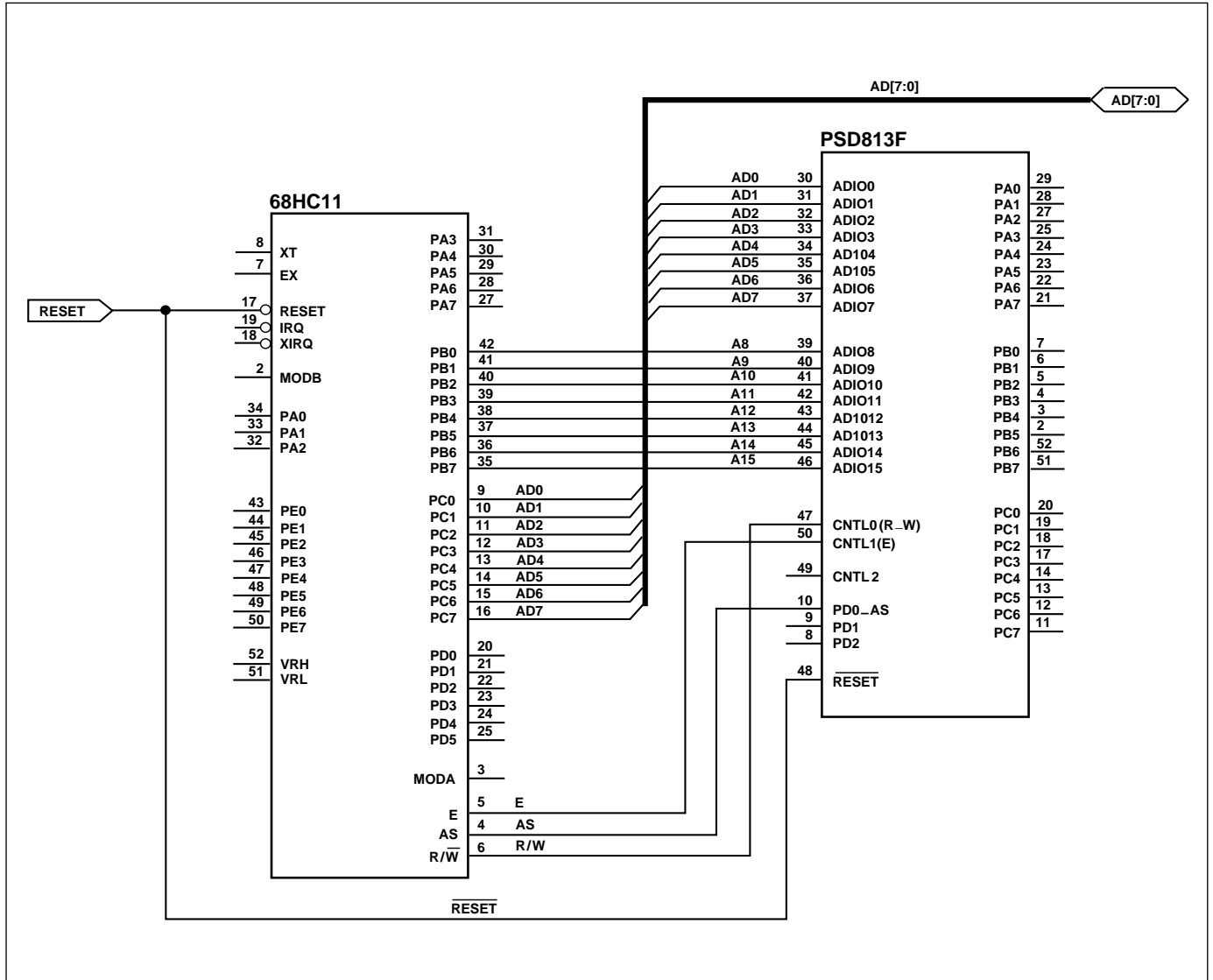


Figure 23. Interfacing the PSD813F1 with a 68HC11



The PSD813F1 Functional Blocks (cont.)

9.4 I/O Ports

There are four programmable I/O ports: Ports A, B, C, and D. Each of the ports is eight bits except Port D, which is 3 bits. Each port pin is individually user configurable, thus allowing multiple functions per port. The ports are configured using PSDsoft Configuration or by the microcontroller writing to on-chip registers in the CSIOP address space.

The topics discussed in this section are:

- General Port Architecture
- Port Operating Modes
- Port Configuration Registers
- Port Data Registers
- Individual Port Functionality.

9.4.1 General Port Architecture

The general architecture of the I/O Port is shown in Figure 24. Individual Port architectures are shown in Figures 26 through 29. In general, once the purpose for a port pin has been defined, that pin will no longer be available for other purposes. Exceptions will be noted.

As shown in Figure 24, the ports contain an output multiplexer whose selects are driven by the configuration bits in the Control Registers (Ports A and B only) and PSDsoft Configuration. Inputs to the multiplexer include the following:

- Output data from the Data Out Register
- Latched address outputs
- CPLD Micro \leftrightarrow Cell output
- External Chip Select from CPLD.

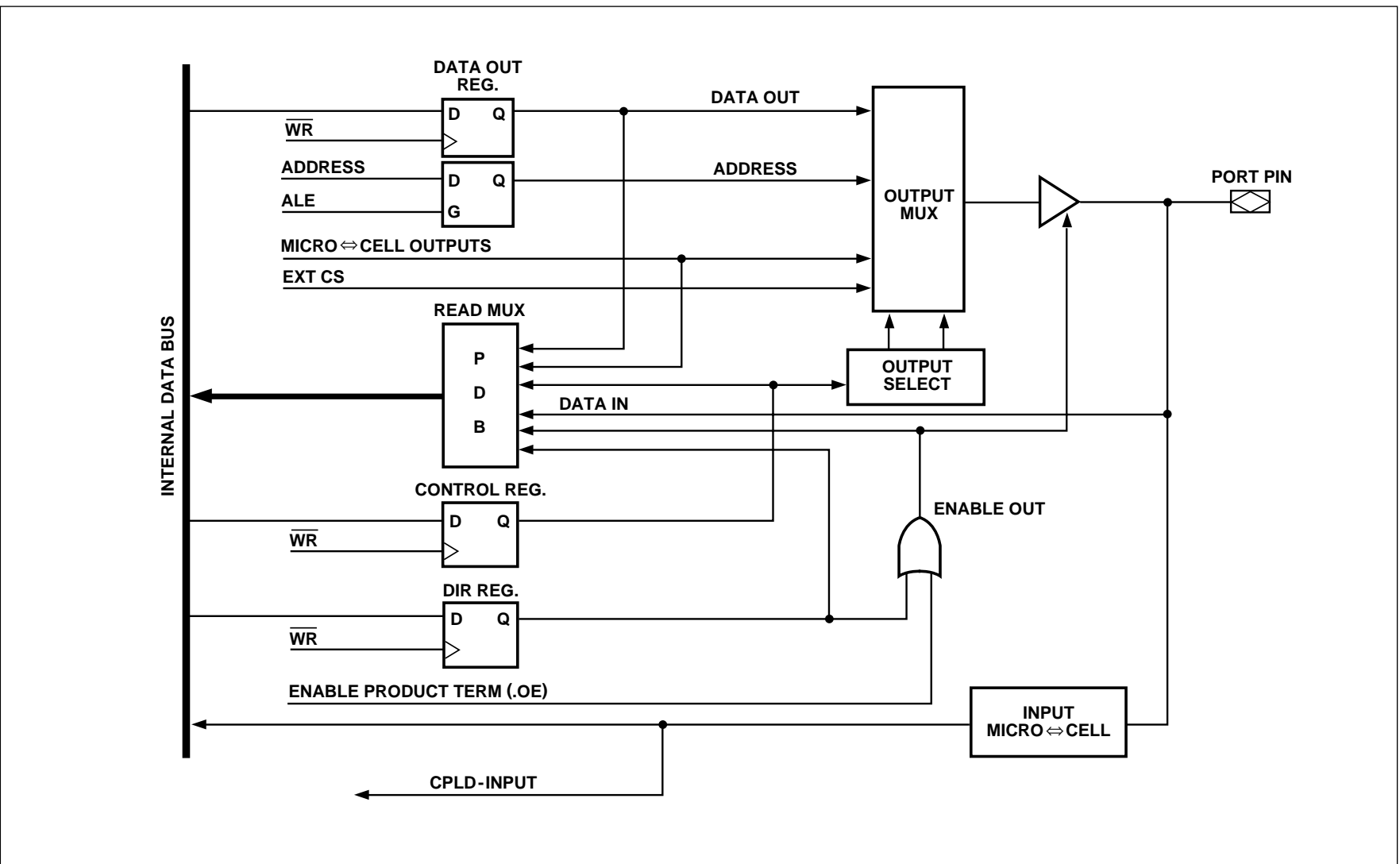
The Port Data Buffer (PDB) is a tri-state buffer that allows only one source at a time to be read. The PDB is connected to the Internal Data Bus for feedback and can be read by the microcontroller. The Data Out and Micro \leftrightarrow Cell outputs, Direction and Control Registers, and port pin input are all connected to the PDB.

The Port pin's tri-state output driver enable is controlled by a two input OR gate whose inputs come from the CPLD AND array enable product term and the Direction Register. If the enable product term of any of the array outputs are not defined and that port pin is not defined as a CPLD output in the PSDabel file, then the Direction Register has sole control of the buffer that drives the port pin.

The contents of these registers can be altered by the microcontroller. The PDB feedback path allows the microcontroller to check the contents of the registers.

Ports A, B, and C have embedded Input Micro \leftrightarrow Cells (IMCs). The IMCs can be configured as latches, registers, or direct inputs to the PLDs. The latches and registers are clocked by the address strobe (AS/ALE) or a product term from the PLD AND array. The outputs from the IMCs drive the PLD input bus and can be read by the microcontroller. Refer to the IMC subsection of the PLD section.

Figure 24. General I/O Port Architecture



The
PSD813F1
Functional
Blocks
(cont.)

9.4.2 Port Operating Modes

The I/O Ports have several modes of operation. Some modes can be defined using PSDabel, some by the microcontroller writing to the Control Registers in CSIOP space, and some by both. The modes that can only be defined using PSDsoft must be programmed into the device and cannot be changed unless the device is reprogrammed. The modes that can be changed by the microcontroller can be done so dynamically at run-time. The PLD I/O, Data Port, Address Input, and Peripheral I/O modes are the only modes that must be defined before programming the device. All other modes can be changed by the microcontroller at run-time. See Application Note 55 for more detail.

Table 20 summarizes which modes are available on each port. Table 23 shows how and where the different modes are configured. Each of the port operating modes are described in the following subsections.

Table 20. Port Operating Modes

| Port Mode | Port A | Port B | Port C | Port D |
|----------------------------|------------|-------------------------|--------|--------|
| MCU I/O | Yes | Yes | Yes | Yes |
| PLD I/O | | | | |
| McellAB Outputs | Yes | Yes | No | No |
| McellBC Outputs | No | Yes | Yes | No |
| Additional Ext. CS Outputs | No | No | No | Yes |
| PLD Inputs | Yes | Yes | Yes | Yes |
| Address Out | Yes (A7–0) | Yes (A7–0) or A15–8) | No | No |
| Address In | Yes | Yes | Yes | Yes |
| Data Port | Yes (D7–0) | No | No | No |
| Peripheral I/O | Yes | No | No | No |
| JTAG ISP | No | No | Yes* | No |

*Can be multiplexed with other I/O functions.

The
PSD813F1
Functional
Blocks
(cont.)

Table 21. Port Operating Mode Settings

| Mode | Defined In PSDlabel | Defined In PSDconfiguration | Control Register Setting | Direction Register Setting | VM Register Setting | JTAG Enable |
|---------------------------|--|-----------------------------|--------------------------|--------------------------------|---------------------|--------------|
| MCU I/O | Declare pins only | NA* | 0 | 1 = output, 0 = input (Note 1) | NA | NA |
| PLD I/O | Logic equations | NA | NA | (Note 1) | NA | NA |
| Data Port (Port A) | NA | Specify bus type | NA | NA | NA | NA |
| Address Out (Port A,B) | Declare pins only | NA | 1 | 1 (Note 1) | NA | NA |
| Address In (Port A,B,C,D) | Logic equation for Input Micro \leftrightarrow Cells | NA | NA | NA | NA | NA |
| Peripheral I/O (Port A) | Logic equations (PSEL0 & 1) | NA | NA | NA | PIO bit = 1 | NA |
| JTAG ISP (Note 2) | JTAGSEL | JTAG Configuration | NA | NA | NA | JTAG_ Enable |

*NA = Not Applicable

NOTE: 1. The direction of the Port A,B,C, and D pins are controlled by the Direction Register ORed with the individual output enable product term (.oe) from the CPLD AND array.
2. Any of these three methods will enable JTAG pins on Port C.

9.4.2.1 MCU I/O Mode

In the MCU I/O Mode, the microcontroller uses the PSD813F1 ports to expand its own I/O ports. By setting up the CSIOP space, the ports on the PSD813F1 are mapped into the microcontroller address space. The addresses of the ports are listed in Table 7.

A port pin can be put into MCU I/O mode by writing a '0' to the corresponding bit in the Control Register. The MCU I/O direction may be changed by writing to the corresponding bit in the Direction Register, or by the output enable product term. See the subsection on the Direction Register in the "Port Registers" section. When the pin is configured as an output, the content of the Data Out Register drives the pin. When configured as an input, the microcontroller can read the port input through the Data In buffer. See Figure 25.

Ports C and D do not have Control Registers, and are in MCU I/O mode by default. They can be used for PLD I/O if equation are written for them in PSDlabel.

9.4.2.2 PLD I/O Mode

The PLD I/O Mode uses a port as an input to the CPLD's Input Micro \leftrightarrow Cells, and/or as an output from the CPLD's Output Micro \leftrightarrow Cells. The output can be tri-stated with a control signal. This output enable control signal can be defined by a product term from the PLD, or by setting the corresponding bit in the Direction Register to '0'. The corresponding bit in the Direction Register must not be set to '1' if the pin is defined as a PLD input pin in PSDlabel. The PLD I/O Mode is specified in PSDlabel by declaring the port pins, and then writing an equation assigning the PLD I/O to a port.

The
PSD813F1
Functional
Blocks
(cont.)

9.4.2.3 Address Out Mode

For microcontrollers with a multiplexed address/data bus, Address Out Mode can be used to drive latched addresses onto the port pins. These port pins can, in turn, drive external devices. Either the output enable or the corresponding bits of both the Direction Register and Control Register must be set to a '1' for pins to use Address Out Mode. This must be done by the MCU at run-time. See Table 22 for the address output pin assignments on Ports A and B for various MCUs.

For non-multiplexed 8 bit bus mode, address lines A[7:0] are available to Port B in Address Out Mode.

Note: do not drive address lines with Address Out Mode to an external memory device if it is intended for the MCU to boot from the external device. The MCU must first boot from PSD memory so the Direction and Control register bits can be set.

Table 22. I/O Port Latched Address Output Assignments

| Microcontroller | Port A (3:0) | Port A (7:4) | Port B (3:0) | Port B (7:4) |
|--------------------------------|---------------|---------------|----------------|-----------------|
| 8051XA (8-Bit) | N/A* | Address (7:4) | Address (11:8) | N/A |
| 80C251 (Page Mode) | N/A | N/A | Address (11:8) | Address (15:12) |
| All Other 8-Bit Multiplexed | Address (3:0) | Address (7:4) | Address (3:0) | Address (7:4) |
| 8-Bit Non-Multiplexed Bus | N/A | N/A | Address [3:0] | Address [7:4] |

N/A = Not Applicable.

9.4.2.4 Address In Mode

For microcontrollers that have more than 16 address lines, the higher addresses can be connected to Port A, B, C, and D. The address input can be latched in the Input MicroCell by the address strobe (ALE/AS). Any input that is included in the DPLD equations for the PLD's Flash, EEPROM, or SRAM is considered to be an address input.

9.4.2.5 Data Port Mode

Port A can be used as a data bus port for a microcontroller with a non-multiplexed address/data bus. The Data Port is connected to the data bus of the microcontroller. The general I/O functions are disabled in Port A if the port is configured as a Data Port.

9.4.2.6 Peripheral I/O Mode

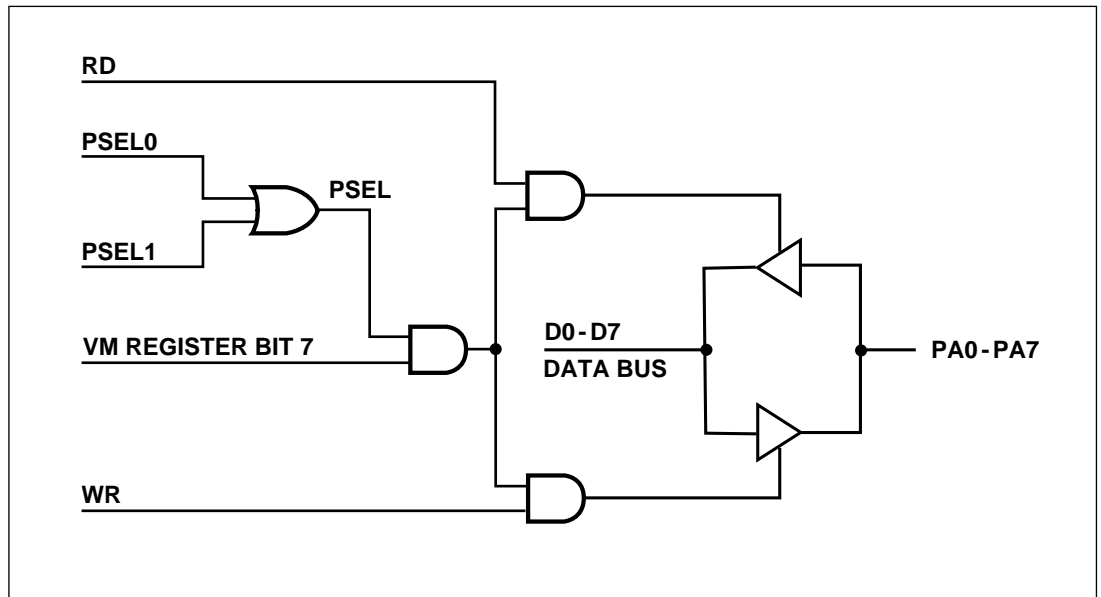
Peripheral I/O Mode can be used to interface with external peripherals. In this mode, all of Port A serves as a tri-stateable, bi-directional data buffer for the microcontroller. Peripheral I/O Mode is enabled by setting Bit 7 of the VM Register to a '1'. Figure 25 shows how Port A acts as a bi-directional buffer for the microcontroller data bus if Peripheral I/O Mode is enabled. An equation for PSEL0 and/or PSEL1 must be written in PSDLabel. The buffer is tri-stated when PSEL 0 or 1 is not active.

9.4.2.7 JTAG ISP

Port C is JTAG compliant, and can be used for In-System Programming (ISP). You can multiplex JTAG operations with other functions on Port C because ISP is not performed during normal system operation. For more information on the JTAG Port, refer to section 9.6.

The PSD813F1 Functional Blocks (cont.)

Figure 25. Peripheral I/O Mode



9.4.3 Port Configuration Registers (PCRs)

Each port has a set of PCRs used for configuration. The contents of the registers can be accessed by the microcontroller through normal read/write bus cycles at the addresses given in Table 7. The addresses in Table 7 are the offsets in hex from the base of the CSIOP register.

The pins of a port are individually configurable and each bit in the register controls its respective pin. For example, Bit 0 in a register refers to Bit 0 of its port. The three PCRs, shown in Table 23, are used for setting the port configurations. The default power-up state for each register in Table 23 is 00h.

Table 23. Port Configuration Registers

| Register Name | Port | MCU Access |
|---------------|---------|------------|
| Control | A,B | Write/Read |
| Direction | A,B,C,D | Write/Read |
| Drive Select* | A,B,C,D | Write/Read |

*NOTE: See Table 27 for Drive Register bit definition.

The PSD813F1 Functional Blocks (cont.)

9.4.3.1 Control Register

Any bit set to '0' in the Control Register sets the corresponding Port pin to MCU I/O Mode, and a '1' sets it to Address Out Mode. The default mode is MCU I/O. Only Ports A and B have an associated Control Register.

9.4.3.2 Direction Register

The Direction Register, in conjunction with the output enable (except for Port D), controls the direction of data flow in the I/O Ports. Any bit set to '1' in the Direction Register will cause the corresponding pin to be an output, and any bit set to '0' will cause it to be an input. The default mode for all port pins is input.

Figures 26 and 28 show the Port Architecture diagrams for Ports A/B and C, respectively. The direction of data flow for Ports A, B, and C are controlled not only by the direction register, but also by the output enable product term from the PLD AND array. If the output enable product term is not active, the Direction Register has sole control of a given pin's direction.

An example of a configuration for a port with the three least significant bits set to output and the remainder set to input is shown in Table 26. Since Port D only contains three pins, the Direction Register for Port D has only the three least significant bits active.

Table 24. Port Pin Direction Control, Output Enable P.T. Not Defined

| Direction Register Bit | Port Pin Mode |
|------------------------|---------------|
| 0 | Input |
| 1 | Output |

Table 25. Port Pin Direction Control, Output Enable P.T. Defined

| Direction Register Bit | Output Enable P.T. | Port Pin Mode |
|------------------------|--------------------|---------------|
| 0 | 0 | Input |
| 0 | 1 | Output |
| 1 | 0 | Output |
| 1 | 1 | Output |

Table 26. Port Direction Assignment Example

| Bit 7 | Bit 6 | Bit 5 | Bit 4 | Bit 3 | Bit 2 | Bit 1 | Bit 0 |
|-------|-------|-------|-------|-------|-------|-------|-------|
| 0 | 0 | 0 | 0 | 0 | 1 | 1 | 1 |

The PSD813F1 Functional Blocks

(cont.)

9.4.3.3 Drive Select Register

The Drive Select Register configures the pin driver as Open Drain or CMOS for some port pins, and controls the slew rate for the other port pins. An external pull-up resistor should be used for pins configured as Open Drain.

A pin can be configured as Open Drain if its corresponding bit in the Drive Select Register is set to a '1'. The default pin drive is CMOS.

Aside: the slew rate is a measurement of the rise and fall times of an output. A higher slew rate means a faster output response and may create more electrical noise. A pin operates in a high slew rate when the corresponding bit in the Drive Register is set to '1'. The default rate is slow slew.

Table 27 shows the Drive Register for Ports A, B, C, and D. It summarizes which pins can be configured as Open Drain outputs and which pins the slew rate can be set for.

Table 27. Drive Register Pin Assignment

| Drive Register | Bit 7 | Bit 6 | Bit 5 | Bit 4 | Bit 3 | Bit 2 | Bit 1 | Bit 0 |
|----------------|------------|------------|------------|------------|------------|------------|------------|------------|
| Port A | Open Drain | Open Drain | Open Drain | Open Drain | Slew Rate | Slew Rate | Slew Rate | Slew Rate |
| Port B | Open Drain | Open Drain | Open Drain | Open Drain | Slew Rate | Slew Rate | Slew Rate | Slew Rate |
| Port C | Open Drain | Open Drain | Open Drain | Open Drain | Open Drain | Open Drain | Open Drain | Open Drain |
| Port D | NA | NA | NA | NA | NA | Slew Rate | Slew Rate | Slew Rate |

NOTE: NA = Not Applicable.

The
PSD813F1
Functional
Blocks
(cont.)

9.4.4 Port Data Registers

The Port Data Registers, shown in Table 28, are used by the microcontroller to write data to or read data from the ports. Table 28 shows the register name, the ports having each register type, and microcontroller access for each register type. The registers are described below.

9.4.4.1 Data In

Port pins are connected directly to the Data In buffer. In MCU I/O input mode, the pin input is read through the Data In buffer.

9.4.4.2 Data Out Register

Stores output data written by the MCU in the MCU I/O output mode. The contents of the Register are driven out to the pins if the Direction Register or the output enable product term is set to "1". The contents of the register can also be read back by the microcontroller.

9.4.4.3 Output Micro \leftrightarrow Cells (OMCs)

The CPLD OMCs occupy a location in the microcontroller's address space. The microcontroller can read the output of the OMCs. If the Mask Micro \leftrightarrow Cell Register bits are not set, writing to the Micro \leftrightarrow Cell loads data to the Micro \leftrightarrow Cell flip flops. Refer to the PLD section for more details.

9.4.4.4 Mask Micro \leftrightarrow Cell Register

Each Mask Register bit corresponds to an OMC flip flop. When the Mask Register bit is set to a "1", loading data into the OMC flip flop is blocked. The default value is "0" or unblocked.

9.4.4.5 Input Micro \leftrightarrow Cells (IMCs)

The IMCs can be used to latch or store external inputs. The outputs of the IMCs are routed to the PLD input bus, and can be read by the microcontroller. Refer to the PLD section for a detailed description.

9.4.4.6 Enable Out

The Enable Out register can be read by the microcontroller. It contains the output enable values for a given port. A "1" indicates the driver is in output mode. A "0" indicates the driver is in tri-state and the pin is in input mode.

Table 28. Port Data Registers

| Register Name | Port | MCU Access |
|-------------------------------------|---------|--|
| Data In | A,B,C,D | Read – input on pin |
| Data Out | A,B,C,D | Write/Read |
| Output Micro \leftrightarrow Cell | A,B,C | Read – outputs of Micro \leftrightarrow Cells Write – loading Micro \leftrightarrow Cells Flip-Flop |
| Mask Micro \leftrightarrow Cell | A,B,C | Write/Read – prevents loading into a given Micro \leftrightarrow Cell |
| Input Micro \leftrightarrow Cell | A,B,C | Read – outputs of the Input Micro \leftrightarrow Cells |
| Enable Out | A,B,C | Read – the output enable control of the port driver |

The
PSD813F1
Functional
Blocks
(cont.)

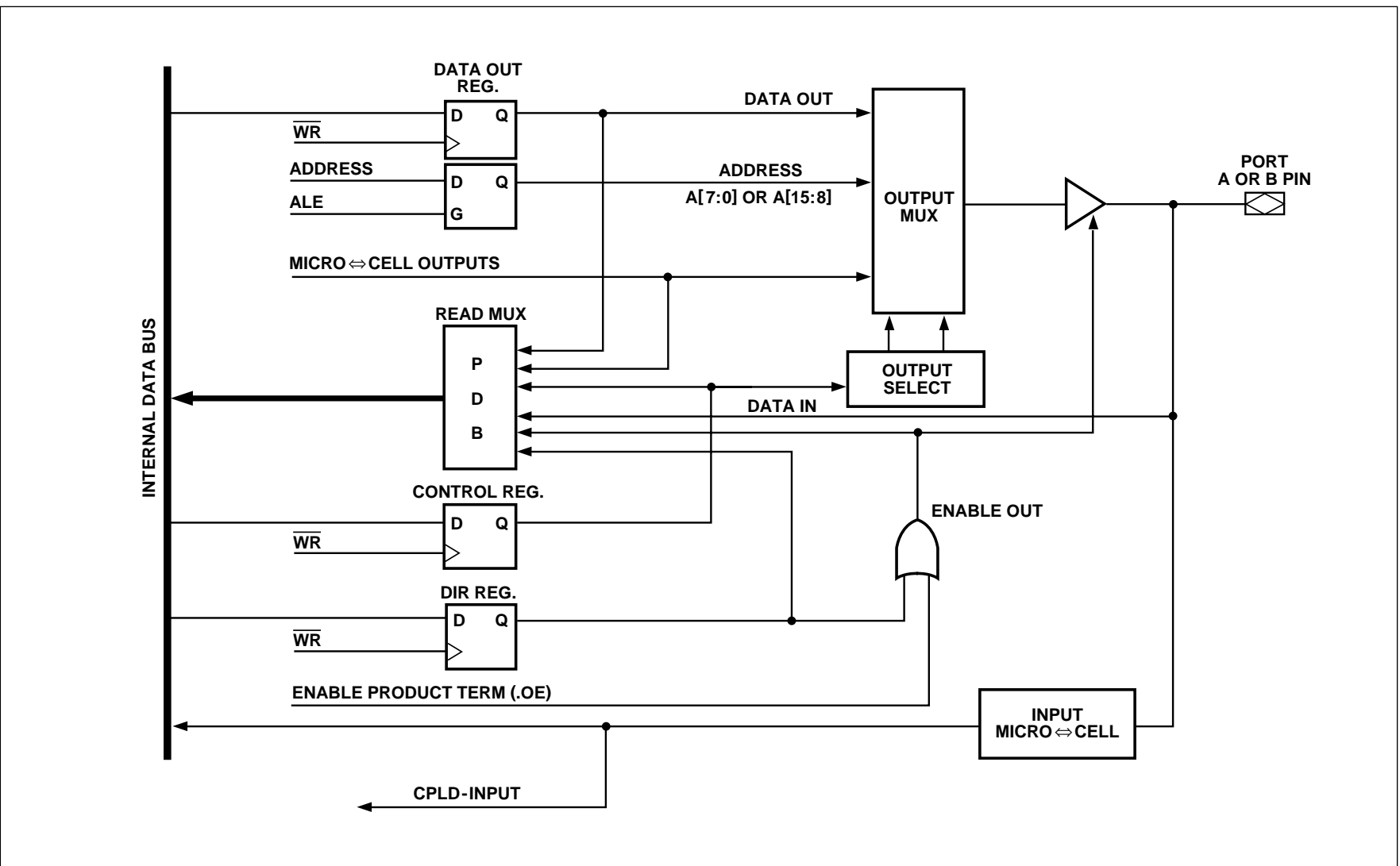
9.4.5 Ports A and B – Functionality and Structure

Ports A and B have similar functionality and structure, as shown in Figure 26. The two ports can be configured to perform one or more of the following functions:

- MCU I/O Mode
- CPLD Output – Micro \leftrightarrow Cells McellAB[7:0] can be connected to Port A or Port B. McellBC[7:0] can be connected to Port B or Port C.
- CPLD Input – Via the input Micro \leftrightarrow Cells.
- Latched Address output – Provide latched address output per Table 30.
- Address In – Additional high address inputs using the Input Micro \leftrightarrow Cells.
- Open Drain/Slew Rate – pins PA[3:0] and PB[3:0] can be configured to fast slew rate, pins PA[7:4] and PB[7:4] can be configured to Open Drain Mode.
- Data Port – Port A to D[7:0] for 8 bit non-multiplexed bus
- Multiplexed Address/Data port for certain types of microcontroller interfaces.
- Peripheral Mode – Port A only

The
PSD813F1
Functional
Blocks
(cont.)

Figure 26. Ports A and B Structure



The PSD813F1 Functional Blocks (cont.)

9.4.6 Port C – Functionality and Structure

Port C can be configured to perform one or more of the following functions (see Figure 28):

- MCU I/O Mode
- CPLD Output – McellBC[7:0] outputs can be connected to Port B or Port C.
- CPLD Input – via the Input Micro \leftrightarrow Cells
- Address In – Additional high address inputs using the Input Micro \leftrightarrow Cells.
- In-System Programming – JTAG port can be enabled for programming/erase of the PSD813F1 device. (See Section 9.6 for more information on JTAG programming.)
- Open Drain – Port C pins can be configured in Open Drain Mode
- Battery Backup features – PC2 can be configured as a Battery Input (Vstby) pin.
PC4 can be configured as a Battery On Indicator output pin, indicating when Vcc is less than Vbat.

Port C does not support Address Out mode, and therefore no Control Register is required. Pin PC7 may be configured as the DBE input in certain microcontroller interfaces.

9.4.7 Port D – Functionality and Structure

Port D has three I/O pins. See Figure 29. This port does not support Address Out mode, and therefore no Control Register is required. Port D can be configured to perform one or more of the following functions:

- MCU I/O Mode
- CPLD Output – (external chip select)
- CPLD Input – direct input to CPLD, no Input Micro \leftrightarrow Cells
- Slew rate – pins can be set up for fast slew rate

Port D pins can be configured in PSDsoft as input pins for other dedicated functions:

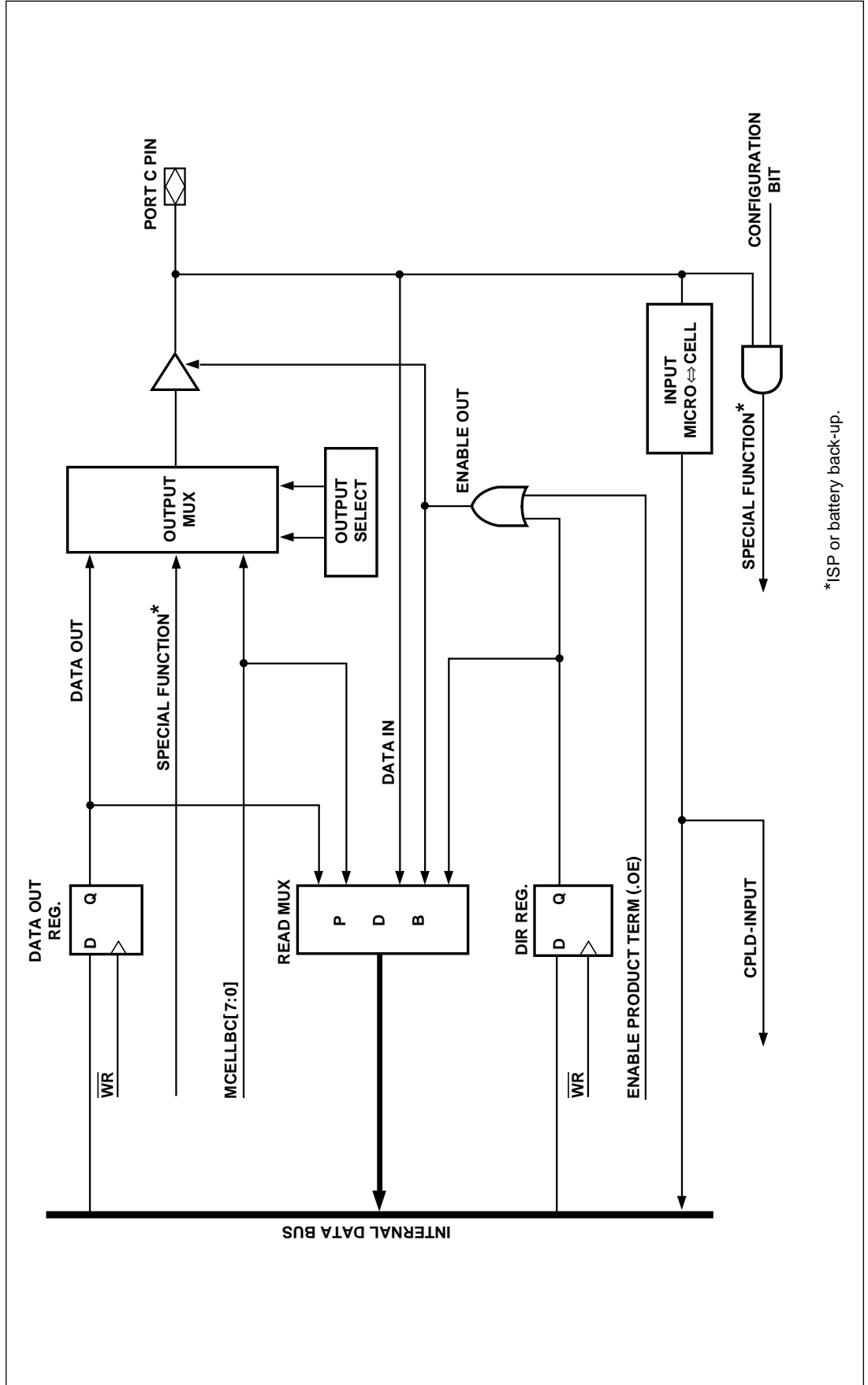
- PD0 – ALE, as address strobe input
- PD1 – CLKIN, as clock input to the Micro \leftrightarrow Cells Flip Flops and APD counter
- PD2 – CSI, as active low chip select input. A high input will disable the Flash/EEPROM/SRAM and CSIOP.

9.4.7.1 External Chip Select

The CPLD also provides three chip select outputs on Port D pins that can be used to select external devices. Each chip select (ECS0-2) consists of one product term that can be configured active high or low. The output enable of the pin is controlled by either the output enable product term or the Direction Register. (See Figure 29.)

The PSD813F1 Functional Blocks (cont.)

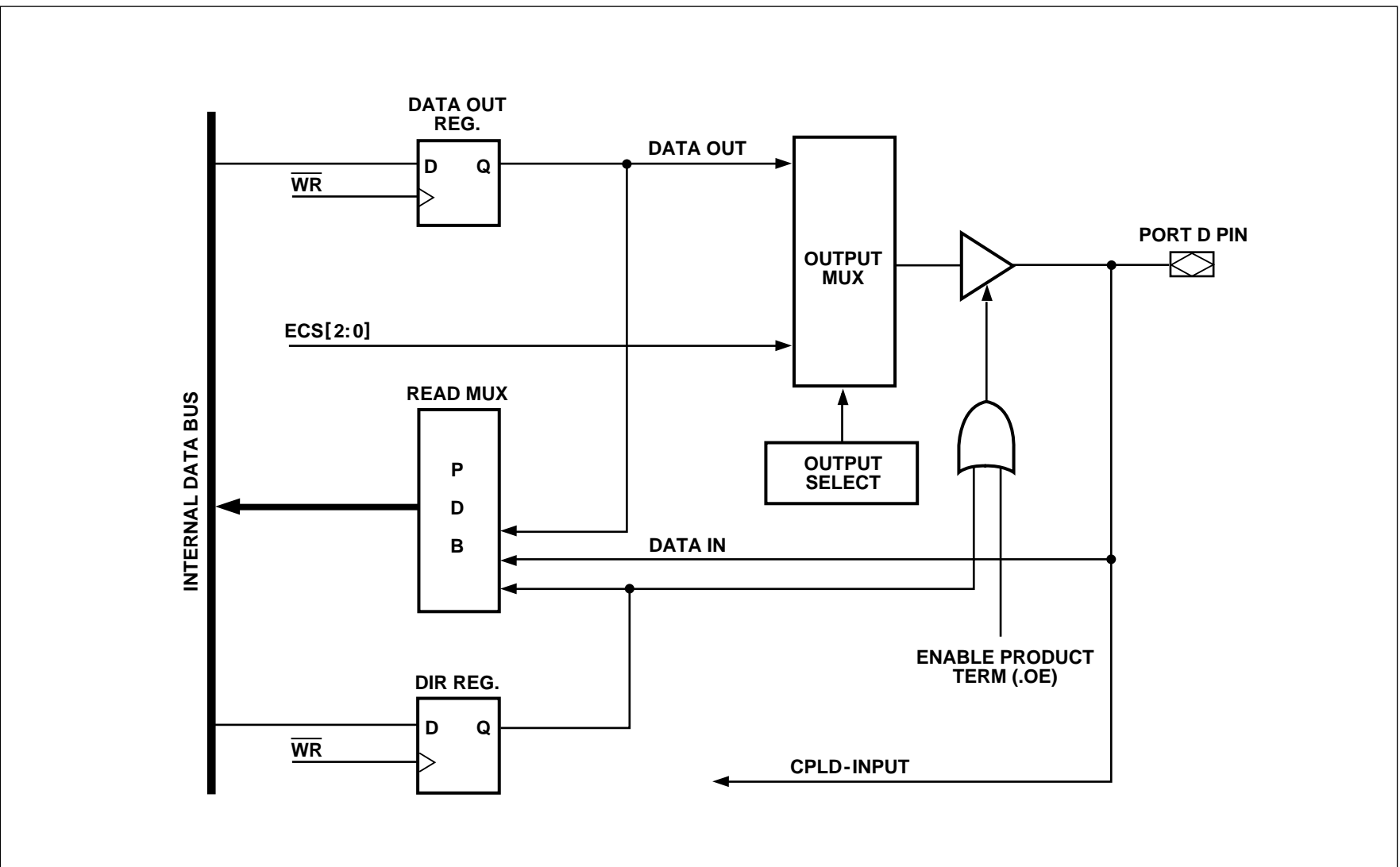
Figure 27. Port C Structure



*ISP or battery back-up.

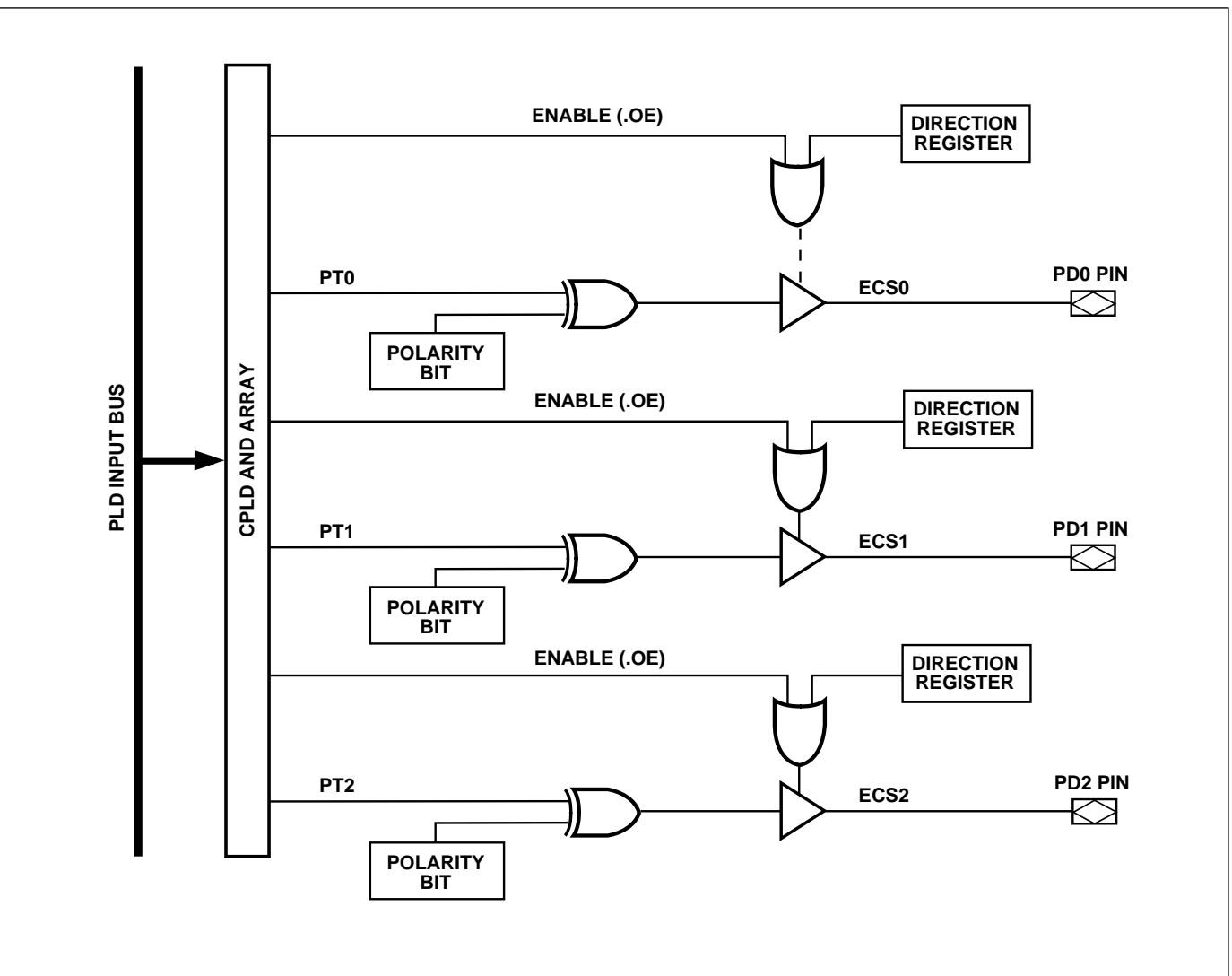


Figure 28. Port D Structure



The
PSD813F1
Functional
Blocks
(cont.)

Figure 29. Port D External Chip Selects



9.5 Power Management

The PSD813F1 offers configurable power saving options. These options may be used individually or in combinations, as follows:

- All memory types in a PSD (Flash, EEPROM, and SRAM) are built with Zero-Power technology. In addition to using special silicon design methodology, Zero-Power technology puts the memories into standby mode when address/data inputs are not changing (zero DC current). As soon as a transition occurs on an input, the affected memory “wakes up”, changes and latches its outputs, then goes back to standby. The designer does **not** have to do anything special to achieve memory standby mode when no inputs are changing—it happens automatically.

The PLD sections can also achieve standby mode when its inputs are not changing, see PMMR registers below.

- Like the Zero-Power feature, the Automatic Power Down (APD) logic allows the PSD to reduce to standby current automatically. The APD will block MCU address/data signals from reaching the memories and PLDs. This feature is available on all PSD813F1 devices. The APD unit is described in more detail in section 9.5.1.

Built in logic will monitor the address strobe of the MCU for activity. If there is no activity for a certain time period (MCU is asleep), the APD logic initiates Power Down Mode (if enabled). Once in Power Down Mode, all address/data signals are blocked from reaching PSD memories and PLDs, and the memories are deselected internally. This allows the memories and PLDs to remain in standby mode even if the address/data lines are changing state externally (noise, other devices on the MCU bus, etc.). Keep in mind that any unblocked PLD input signals that are changing states keeps the PLD out of standby mode, but not the memories.

- The PSD Chip Select Input (CSI) on all families can be used to disable the internal memories, placing them in standby mode even if inputs are changing. This feature does not block any internal signals or disable the PLDs. This is a good alternative to using the APD logic, especially if your MCU has a chip select output. There is a slight penalty in memory access time when the CSI signal makes its initial transition from deselected to selected.
- The PMMR registers can be written by the MCU at run-time to manage power. PSD813F1 supports “blocking bits” in these registers that are set to block designated signals from reaching both PLDs. Current consumption of the PLDs is directly related to the composite frequency of the changes on their inputs (see Figures 34 and 34a). Significant power savings can be achieved by blocking signals that are not used in DPLD or CPLD logic equations.

The PSD813F1 has a Turbo Bit in the PMMR0 register. This bit can be set to disable the Turbo Mode feature (default is Turbo Mode on). While Turbo Mode is disabled, the PLDs can achieve standby current when no PLD inputs are changing (zero DC current). Even when inputs do change, significant power can be saved at lower frequencies (AC current), compared to when Turbo Mode is enabled. When the Turbo Mode is enabled, there is a significant DC current component and the AC component is higher.

9.5.1 Automatic Power Down (APD) Unit and Power Down Mode

The APD Unit, shown in Figure 30, puts the PSD into Power Down Mode by monitoring the activity of the address strobe (ALE/AS). If the APD unit is enabled, as soon as activity on the address strobe stops, a four bit counter starts counting. If the address strobe remains inactive for fifteen clock periods of the CLKIN signal, the Power Down (PDN) signal becomes active, and the PSD will enter into Power Down Mode, discussed next.

The PSD813F1 Functional Blocks (cont.)

9.5.1 Automatic Power Down (APD) Unit and Power Down Mode (cont.)

Power Down Mode

By default, if you enable the PSD APD unit, Power Down Mode is automatically enabled. The device will enter Power Down Mode if the address strobe (ALE/AS) remains inactive for fifteen CLKIN (pin PD1) clock periods.

The following should be kept in mind when the PSD is in Power Down Mode:

- If the address strobe starts pulsing again, the PSD will return to normal operation. The PSD will also return to normal operation if either the CSI input returns low or the Reset input returns high.
- The MCU address/data bus is blocked from all memories and PLDs.
- Various signals can be blocked (prior to Power Down Mode) from entering the PLDs by setting the appropriate bits in the PMMR registers. The blocked signals include MCU control signals and the common clock (CLKIN). Note that blocking CLKIN from the PLDs will not block CLKIN from the APD unit.
- All PSD memories enter Standby Mode and are drawing standby current. However, the PLDs and I/O ports do **not** go into Standby Mode because you don't want to have to wait for the logic and I/O to "wake-up" before their outputs can change. See table 29 for Power Down Mode effects on PSD ports.
- Typical standby current is 50 μ A for 5 V devices, and 25 μ A for 3 V devices. These standby current values assume that there are no transitions on any PLD input.

Table 29. Power Down Mode's Effect on Ports

| Port Function | Pin Level |
|----------------|-------------|
| MCU I/O | No Change |
| PLD Out | No Change |
| Address Out | Undefined |
| Data Port | Three-State |
| Peripheral I/O | Three-State |

Table 30. PSD813F1 Timing and Standby Current During Power Down Mode

| Mode | PLD Propagation Delay | Memory Access Time | Access Recovery Time to Normal Access | 5V V _{CC} , Typical Standby Current |
|------------|-----------------------|--------------------|---------------------------------------|--|
| Power Down | Normal tpd (Note 1) | No Access | tLVDV | 50 μ A (Note 2) |

- NOTES:**
1. Power Down does not affect the operation of the PLD. The PLD operation in this mode is based only on the Turbo Bit.
 2. Typical current consumption assuming no PLD inputs are changing state and the PLD Turbo bit is off.

HC11 (or compatible) Users Note

The HC11 turns off its E clock when it sleeps. Therefore, if you are using an HC11 (or compatible) in your design, and you wish to use the Power Down, you must not connect the E clock to the CLKIN input (PD1). You should instead connect an independent clock signal to the CLKIN input. The clock frequency must be **less than** 15 times the frequency of AS. The reason for this is that if the frequency is greater than 15 times the frequency of AS, the PSD813F1 will keep going into Power Down Mode.



The PSD813F1 Functional Blocks (cont.)

Figure 30. APD Logic Block

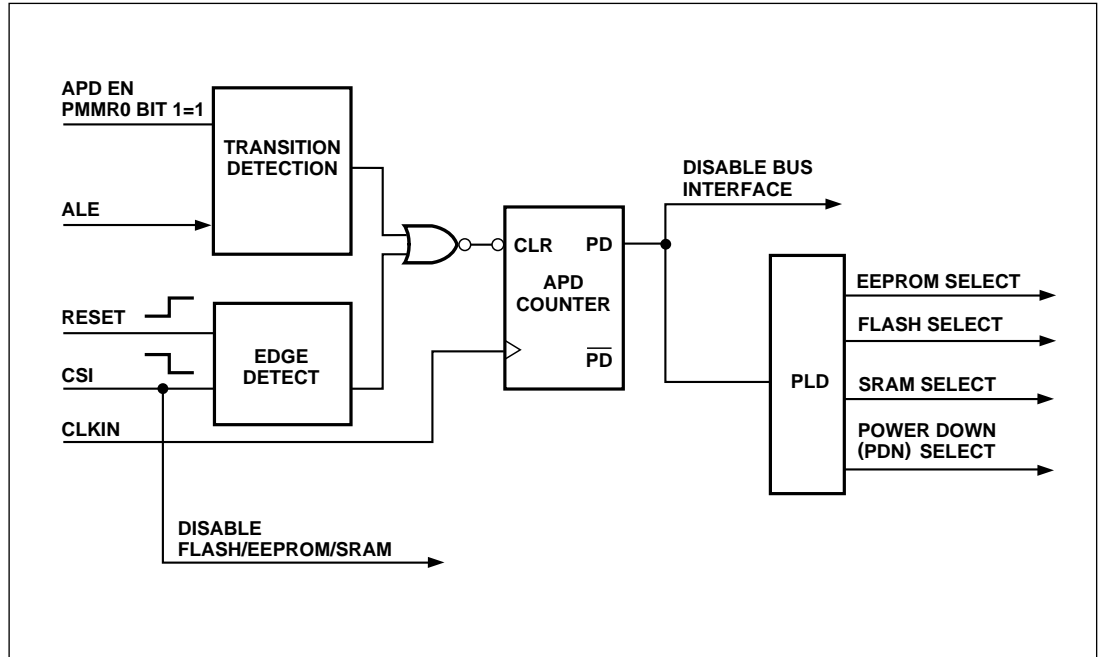
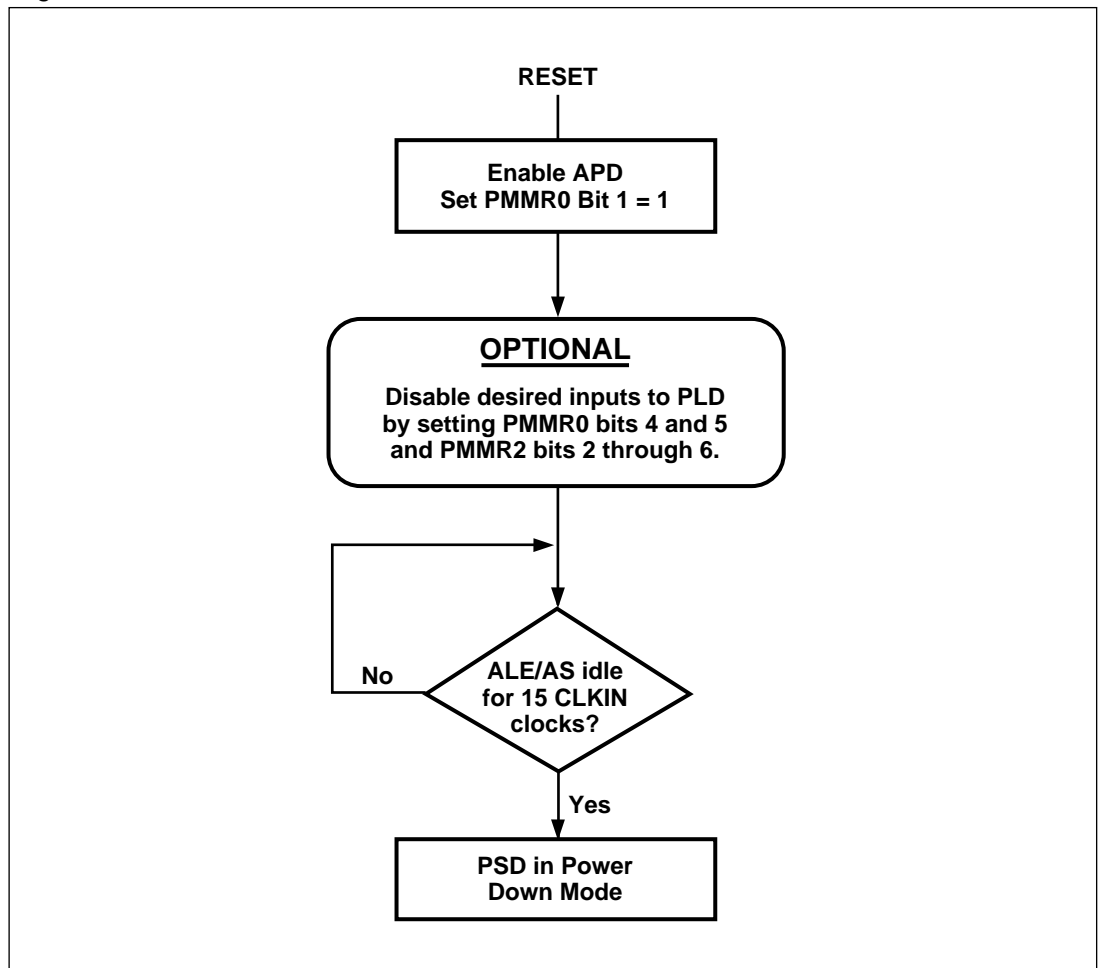


Figure 31. Enable Power Down Flow Chart



The
PSD813F1
Functional
Blocks
(cont.)

Table 31. Power Management Mode Registers (PMMR0, PMMR2)**
PMMR0

| Bit 7 | Bit 6 | Bit 5 | Bit 4 | Bit 3 | Bit 2 | Bit 1 | Bit 0 |
|-------|-------|------------------|------------------|--------------|-------|---------------|-------|
| * | * | PLD Mcell clk | PLD Array clk | PLD Turbo | * | APD Enable | * |
| | | 1 = off | 1 = off | 1 = off | | 1 = on | |

*Bits 0, 2, 6, and 7 are not used, and should be set to 0.

**The PMMR0, and PMMR2 register bits are cleared to zero following power up. Subsequent reset pulses will not clear the registers.

- Bit 1 0 = Automatic Power Down (APD) is disabled.
1 = Automatic Power Down (APD) is enabled.
- Bit 3 0 = PLD Turbo is on.
1 = PLD Turbo is off, saving power.
- Bit 4 0 = CLKIN input to the PLD AND array is connected.
Every CLKIN change will power up the PLD when Turbo bit is off.
1 = CLKIN input to PLD AND array is disconnected, saving power.
- Bit 5 0 = CLKIN input to the PLD Micro↔Cells is connected.
1 = CLKIN input to PLD Micro↔Cells is disconnected, saving power.

PMMR2

| Bit 7 | Bit 6 | Bit 5 | Bit 4 | Bit 3 | Bit 2 | Bit 1 | Bit 0 |
|-------|---------------------|---------------------|-----------------------|-----------------------|-----------------------|-------|-------|
| * | PLD array DBE | PLD array ALE | PLD array CNTL2 | PLD array CNTL1 | PLD array CNTL0 | * | * |
| | 1 = off | 1 = off | 1 = off | 1 = off | 1 = off | | |

*Unused bits should be set to 0.

- Bit 2 0 = Cntl0 input to the PLD AND array is connected.
1 = Cntl0 input to PLD AND array is disconnected, saving power.
- Bit 3 0 = Cntl1 input to the PLD AND array is connected.
1 = Cntl1 input to PLD AND array is disconnected, saving power.
- Bit 4 0 = Cntl2 input to the PLD AND array is connected.
1 = Cntl2 input to PLD AND array is disconnected, saving power.
- Bit 5 0 = ALE input to the PLD AND array is connected.
1 = ALE input to PLD AND array is disconnected, saving power.
- Bit 6 0 = DBE input to the PLD AND array is connected.
1 = DBE input to PLD AND array is disconnected, saving power.



The
PSD813F1
Functional
Blocks
(cont.)

Table 32. APD Counter Operation

| APD Enable Bit | ALE PD Polarity | ALE Level | APD Counter |
|----------------|-----------------|-----------|--|
| 0 | X | X | Not Counting |
| 1 | X | Pulsing | Not Counting |
| 1 | 1 | 1 | Counting (Generates PDN after 15 Clocks) |
| 1 | 0 | 0 | Counting (Generates PDN after 15 Clocks) |

9.5.2 Other Power Saving Options

The PSD813F1 offers other reduced power saving options that are independent of the Power Down Mode. Except for the SRAM Standby and CSI input features, they are enabled by setting bits in the PMMR0 and PMMR2 registers.

9.5.2.1 Zero Power PLD

The power and speed of the PLDs are controlled by the Turbo bit (bit 3) in the PMMR0. By setting the bit to “1”, the Turbo mode is disabled and the PLDs consume Zero Power current when the inputs are not switching for an extended time of 70 ns. The propagation delay time will be increased by 10 ns after the Turbo bit is set to “1” (turned off) when the inputs change at a composite frequency of less than 15 MHz. When the Turbo bit is set to a “0” (turned on), the PLDs run at full power and speed. The Turbo bit affects the PLD’s D.C. power, AC power, and propagation delay.

Note: Blocking MCU control signals with PMMR2 bits can further reduce PLD AC power consumption.

9.5.2.2 SRAM Standby Mode (Battery Backup)

The PSD813F1 supports a battery backup operation that retains the contents of the SRAM in the event of a power loss. The SRAM has a Vstby pin (PC2) that can be connected to an external battery. When V_{CC} becomes lower than Vstby then the PSD will automatically connect to Vstby as a power source to the SRAM. The SRAM Standby Current (Istby) is typically 0.5 μ A. The SRAM data retention voltage is 2 V minimum. The battery-on indicator (Vbaton) can be routed to PC4. This signal indicates when the V_{CC} has dropped below the Vstby voltage.

9.5.2.3 The CSI Input

Pin PD2 of Port D can be configured in PSDsoft as the CSI input. When low, the signal selects and enables the internal Flash, EEPROM, SRAM, and I/O for read or write operations involving the PSD813F1. A high on the CSI pin will disable the Flash memory, EEPROM, and SRAM, and reduce the PSD power consumption. However, the PLD and I/O pins remain operational when CSI is high. **Note:** there may be a timing penalty when using the CSI pin depending on the speed grade of the PSD that you are using. See the timing parameter t_{SLQV} in the AC/DC specs.

9.5.2.4 Input Clock

The PSD813F1 provides the option to turn off the CLKIN input to the PLD to save AC power consumption. The CLKIN is an input to the PLD AND array and the Output Micro \leftrightarrow Cells. During Power Down Mode, or, if the CLKIN input is not being used as part of the PLD logic equation, the clock should be disabled to save AC power. The CLKIN will be disconnected from the PLD AND array or the Micro \leftrightarrow Cells by setting bits 4 or 5 to a “1” in PMMR0.

9.5.2.5 Input Control Signals

The PSD813F1 provides the option to turn off the input control signals (CNTL0-2, ALE, and DBE) to the PLD to save AC power consumption. These control signals are inputs to the PLD AND array. During Power Down Mode, or, if any of them are not being used as part of the PLD logic equation, these control signals should be disabled to save AC power. They will be disconnected from the PLD AND array by setting bits 2, 3, 4, 5, and 6 to a “1” in the PMMR2.

The PSD813F1 Functional Blocks (cont.)

9.5.3 Reset and Power On Requirement

Power On Reset

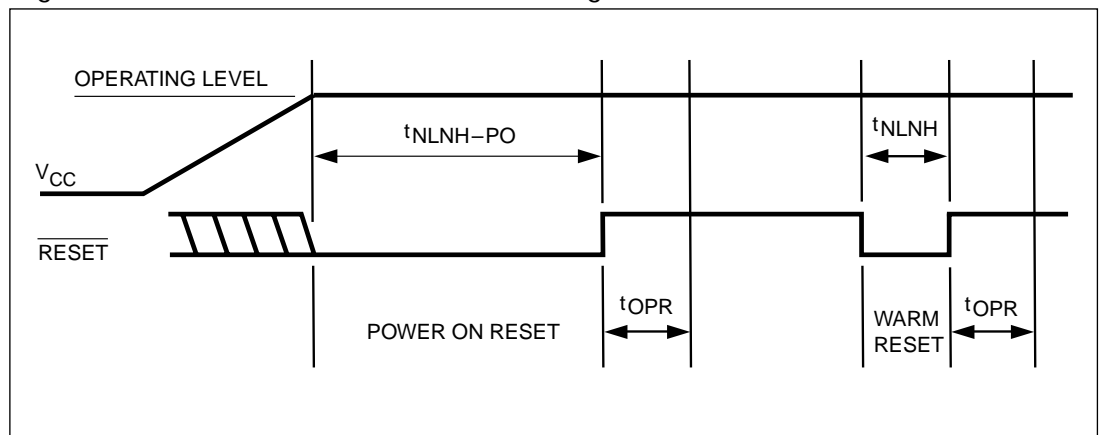
Upon power up the PSD813F1 requires a reset pulse of $t_{NLNH-PO}$ (minimum 1ms) after V_{CC} is steady. During this time period the device loads internal configurations, clears some of the registers and sets the Flash or EEPROM into operating mode. After the rising edge of reset, the PSD813F1 remains in the reset state for an additional t_{OPR} (minimum 120 ns) nanoseconds before the first memory access is allowed.

The PSD813F1 Flash or EEPROM memory is reset to the read array mode upon power up. The FSi and EESi select signals along with the write strobe signal must be in the false state during power-up reset for maximum security of the data contents and to remove the possibility of a byte being written on the first edge of a write strobe signal. The PSD automatically prevents write strobes from reaching the EEPROM memory array for about 5 ms (t_{EEHWL}). Any Flash memory write cycle initiation is prevented automatically when V_{CC} is below VLKO.

Warm Reset

Once the device is up and running, the device can be reset with a much shorter pulse of t_{NLNH} (minimum 150 ns). The same t_{OPR} time is needed before the device is operational after warm reset. Figure 32 shows the timing of the power on and warm reset.

Figure 32. Power On and Warm Reset Timing



I/O Pin, Register and PLD Status at Reset

Table 33 shows the I/O pin, register and PLD status during power on reset, warm reset and power down mode. PLD outputs are always valid during warm reset, and they are valid in power on reset once the internal PSD configuration bits are loaded. This loading of PSD is completed typically long before the V_{CC} ramps up to operating level. Once the PLD is active, the state of the outputs are determined by the PSDlabel equations.

The
PSD813F1
Functional
Blocks
(cont.)

Table 33. Status During Power On Reset, Warm Reset and Power Down Mode

| Port Configuration | Power On Reset | Warm Reset | Power Down Mode |
|--------------------|--|------------|--|
| MCU I/O | Input Mode | Input Mode | Unchanged |
| PLD Output | Valid after internal PSD configuration bits are loaded | Valid | Depend on inputs to PLD (address are blocked in PD mode) |
| Address Out | Tri-stated | Tri-stated | Not defined |
| Data Port | Tri-stated | Tri-stated | Tri-stated |
| Peripheral I/O | Tri-stated | Tri-stated | Tri-stated |

| Register | Power On Reset | Warm Reset | Power Down Mode |
|--|---|--|---------------------------------|
| PMMR0, 2 | Cleared to "0" | Unchanged | Unchanged |
| Micro \leftrightarrow Cells Flip Flop status | Cleared to "0" by internal power on reset | Depend on .re and .pr equations | Depend on .re and .pr equations |
| VM Register* | Initialized based on the selection in PSDsoft Configuration Menu. | Initialized based on the selection in PSDsoft Configuration Menu | Unchanged |
| All other registers | Cleared to "0" | Cleared to "0" | Unchanged |

*SR_cod and Periph Mode bits in the VM Register are always cleared to zero on power on or warm reset.

9.6 Programming In-Circuit using the JTAG Interface

The JTAG interface on the PSD813F1 can be enabled on Port C (see Table 34). All memory (Flash and EEPROM), PLD logic, and PSD configuration bits may be programmed through the JTAG interface. A blank part can be mounted on a printed circuit board and programmed using JTAG.

The standard JTAG signals (IEEE 1149.1) are TMS, TCK, TDI, and TDO. Two additional signals, $\overline{\text{TSTAT}}$ and $\overline{\text{TERR}}$, are optional JTAG extensions used to speed up program and erase operations.

By default, on a blank PSD (as shipped from factory or after erasure), four pins on Port C are enabled for the basic JTAG signals TMS, TCK, TDI, and TDO.

See Application Note 54 for more details on JTAG In-System-Programming.

Table 34. JTAG Port Signals

| Port C Pin | JTAG Signals | Description |
|------------|---------------------------|-----------------|
| PC0 | TMS | Mode Select |
| PC1 | TCK | Clock |
| PC3 | $\overline{\text{TSTAT}}$ | Status |
| PC4 | $\overline{\text{TERR}}$ | Error Flag |
| PC5 | TDI | Serial Data In |
| PC6 | TDO | Serial Data Out |

The
PSD813F1
Functional
Blocks
(cont.)

9.6.1 Standard JTAG Signals

The standard JTAG signals (TMS, TCK, TDI, and TDO) can be enabled by any of three different conditions that are logically ORed. When enabled, TDI, TDO, TCK, and TMS are inputs, waiting for a serial command from an external JTAG controller device (such as FlashLink or Automated Test Equipment). When the enabling command is received from the external JTAG controller, TDO becomes an output and the JTAG channel is fully functional inside the PSD. The same command that enables the JTAG channel may optionally enable the two additional JTAG pins, TSTAT and TERR.

The following symbolic logic equation specifies the conditions enabling the four basic JTAG pins (TMS, TCK, TDI, and TDO) on their respective Port C pins. For purposes of discussion, the logic label JTAG_ON will be used. When JTAG_ON is true, the four pins are enabled for JTAG. When JTAG_ON is false, the four pins can be used for general PSD I/O.

```
JTAG_ON = PSDsoft_enabled +
          /* An NVM configuration bit inside the PSD is set by the designer
           in the PSDsoft Configuration utility. This dedicates the pins for
           JTAG at all times (compliant with IEEE 1149.1) */

          Microcontroller_enabled +
          /* The microcontroller can set a bit at run-time by writing to the
           PSD register, JTAG Enable. This register is located at address
           CSIOP + offset C7h. Setting the JTAG_ENABLE bit in this
           register will enable the pins for JTAG use. This bit is cleared
           by a PSD reset or the microcontroller. See Table 35 for bit
           definition. */

          PSD_product_term_enabled;
          /* A dedicated product term (PT) inside the PSD can be used to
           enable the JTAG pins. This PT has the reserved name
           JTAGSEL. Once defined as a node in PSDabel, the designer
           can write an equation for JTAGSEL. This method is used when
           the Port C JTAG pins are multiplexed with other I/O signals.
           It is recommended to logically tie the node JTAGSEL to the
           JEN\ signal on the Flashlink cable when multiplexing JTAG
           signals. See Application Note 54 for details.
```

Table 35. JTAG Enable Register
JTAG Enable

| Bit 7 | Bit 6 | Bit 5 | Bit 4 | Bit 3 | Bit 2 | Bit 1 | Bit 0 |
|-------|-------|-------|-------|-------|-------|-------|-------------|
| * | * | * | * | * | * | * | JTAG_ENABLE |

*Bits 1-7 are not used and should set to 0.

Bit definitions:

JTAG_ENABLE 1 = JTAG Port is Enabled.
0 = JTAG Port is Disabled.



The
PSD813F1
Functional
Blocks
(cont.)

9.6.1 Standard JTAG Signals (cont.)

The PSD813F1 supports JTAG In-System-Configuration (ISC) commands, but not Boundary Scan. A definition of these JTAG-ISC commands and sequences are defined in a supplemental document available from ST. ST's PSDsoft software tool and FlashLink JTAG programming cable implement these JTAG-ISC commands. This document is needed only as a reference for designers who use a FlashLink to program their PSD813F1.

9.6.2 JTAG Extensions

\overline{TSTAT} and \overline{TERR} are two JTAG extension signals enabled by an "ISC_ENABLE" command received over the four standard JTAG pins (TMS, TCK, TDI, and TDO). They are used to speed programming and erase functions by indicating status on PSD pins instead of having to scan the status out serially using the standard JTAG channel. See Application Note 54.

\overline{TERR} will indicate if an error has occurred when erasing a sector or programming a byte in Flash memory. This signal will go low (active) when an error condition occurs, and stay low until an "ISC_CLEAR" command is executed or a chip reset pulse is received after an "ISC-DISABLE" command. \overline{TERR} does not apply to EEPROM.

\overline{TSTAT} behaves the same as the Rdy/Bsy signal described in section 9.1.1.2. \overline{TSTAT} will be high when the PSD813F1 device is in read array mode (Flash memory and EEPROM contents can be read). \overline{TSTAT} will be low when Flash memory programming or erase cycles are in progress, and also when data is being written to EEPROM.

\overline{TSTAT} and \overline{TERR} can be configured as open-drain type signals during an "ISC_ENABLE" command. This facilitates a wired-OR connection of \overline{TSTAT} signals from several PSD813F1 devices and a wired-OR connection of \overline{TERR} signals from those same devices. This is useful when several PSD813F1 devices are "chained" together in a JTAG environment.

9.6.3 Security and Flash Memories and EEPROM Protection

When the security bit is set, the device cannot be read on a device programmer or through the JTAG Port. When using the JTAG Port, only a full chip erase command is allowed. All other program/erase/verify commands are blocked. Full chip erase returns the part to a non-secured blank state. The Security Bit can be set in PSDsoft Configuration.

All Flash Memory and EEPROM sectors can individually be sector protected against erasures. The sector protect bits can be set in PSDsoft Configuration.

Absolute
Maximum
Ratings

| Symbol | Parameter | Condition | Min | Max | Unit |
|-----------|----------------------------------|---------------------|-------|-------|------|
| T_{STG} | Storage Temperature | PLDCC | - 65 | + 125 | °C |
| | Operating Temperature | Commercial | 0 | + 70 | °C |
| | | Industrial | - 40 | + 85 | °C |
| | Voltage on any Pin | With Respect to GND | - 0.6 | + 7 | V |
| V_{PP} | Device Programmer Supply Voltage | With Respect to GND | - 0.6 | + 14 | V |
| V_{CC} | Supply Voltage | With Respect to GND | - 0.6 | + 7 | V |
| | ESD Protection | | >2000 | | V |

NOTE: Stresses above those listed under Absolute Maximum Ratings may cause permanent damage to the device. This is a stress rating only and functional operation of the device at these or any other conditions above those indicated in the operational sections of this specification is not recommended. Exposure to Absolute Maximum Rating conditions for extended periods of time may affect device reliability.

Operating
Range

| Range | Temperature | V_{CC} Tolerance |
|------------|-----------------|--------------------|
| Commercial | 0° C to +70°C | + 5 V ± 10% |
| Industrial | -40° C to +85°C | + 5 V ± 10% |
| Commercial | 0° C to +70°C | 3 V to 3.6 V |
| Industrial | -40° C to +85°C | 3 V to 3.6 V |

Recommended
Operating
Conditions

| Symbol | Parameter | Condition | Min | Typ | Max | Unit |
|----------|----------------|--------------------------|-----|-----|-----|------|
| V_{CC} | Supply Voltage | All Speeds | 4.5 | 5 | 5.5 | V |
| V_{CC} | Supply Voltage | V-Versions All Speeds | 3.0 | | 3.6 | V |

AC/DC Parameters

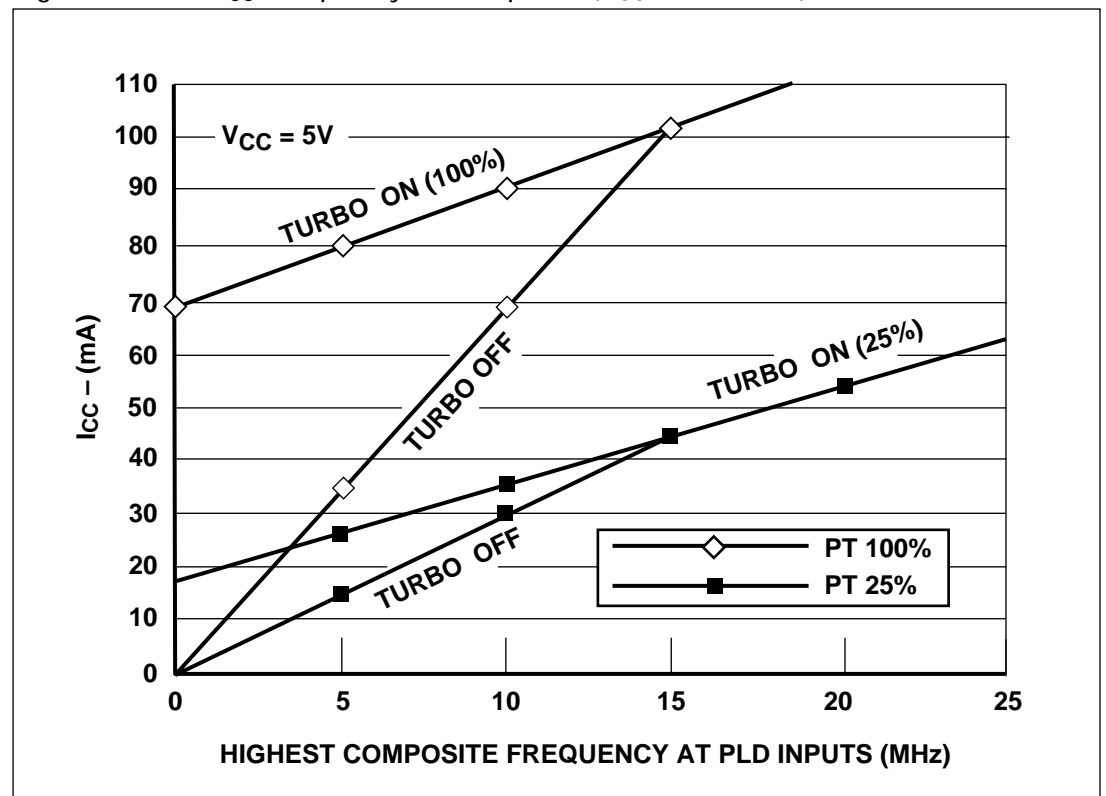
The following tables describe the AD/DC parameters of the PSD813F1 family:

- DC Electrical Specification
- AC Timing Specification
 - PLD Timing
 - Combinatorial Timing
 - Synchronous Clock Mode
 - Asynchronous Clock Mode
 - Input Micro↔Cell Timing
 - Microcontroller Timing
 - Read Timing
 - Write Timing
 - Peripheral Mode Timing
 - Power Down and Reset Timing

Following are issues concerning the parameters presented:

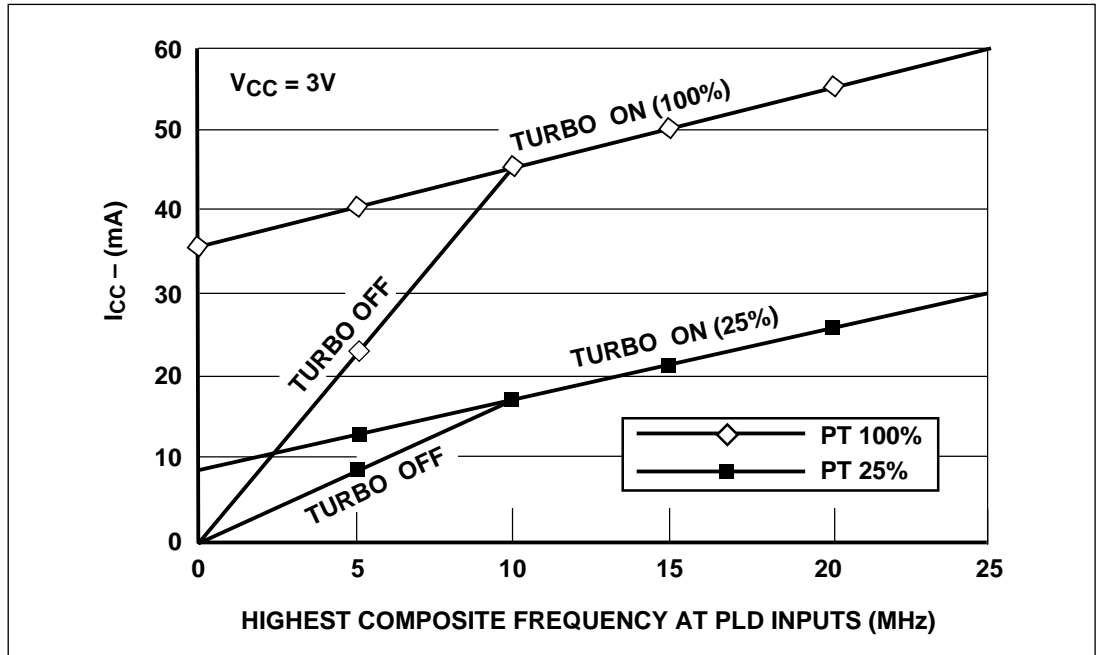
- In the DC specification the supply current is given for different modes of operation. Before calculating the total power consumption, determine the percentage of time that the PSD813F1 is in each mode. Also, the supply power is considerably different if the Turbo bit is "OFF".
- The AC power component gives the PLD, EPROM, and SRAM mA/MHz specification. Figures 33 and 33a show the PLD mA/MHz as a function of the number of Product Terms (PT) used.
- In the PLD timing parameters, add the required delay when Turbo bit is "OFF".

Figure 33. PLD I_{CC} /FrequencyConsumption ($V_{CC} = 5V \pm 10\%$)



AC/DC
Parameters
(cont.)

Figure 33a. PLD I_{CC} /Frequency Consumption (PSD813FV Versions, $V_{CC} = 3\text{ V}$)



Example of PSD813F Typical Power Calculation at $V_{CC} = 5.0\text{ V}$

| Conditions | |
|---|---------------------------------------|
| Highest Composite PLD input frequency (Freq PLD) | = 8 MHz |
| MCU ALE frequency (Freq ALE) | = 4 MHz |
| % Flash Access | = 80% |
| % SRAM access | = 15% |
| % I/O access | = 5% (no additional power above base) |
| Operational Modes | |
| % Normal | = 10% |
| % Power Down Mode | = 90% |
| Number of product terms used (from fitter report) | |
| | = 45 PT |
| % of total product terms | = 45/182 = 24.7% |
| Turbo Mode | = ON |
| Calculation (typical numbers used) | |
| $I_{CC\ total} = I_{pwrdown} \times \%pwrdown + \%normal \times (I_{CC\ (ac)} + I_{CC\ (dc)})$ $= I_{pwrdown} \times \%pwrdown + \%normal \times (\%flash \times 2.5\text{ mA/MHz} \times \text{Freq ALE} + \%SRAM \times 1.5\text{ mA/MHz} \times \text{Freq ALE} + \%PLD \times 2\text{ mA/MHz} \times \text{Freq PLD} + \#PT \times 400\ \mu\text{A/PT})$ $= 50\ \mu\text{A} \times 0.90 + 0.1 \times (0.8 \times 2.5\text{ mA/MHz} \times 4\text{ MHz} + 0.15 \times 1.5\text{ mA/MHz} \times 4\text{ MHz} + 2\text{ mA/MHz} \times 8\text{ MHz} + 45 \times 0.4\text{ mA/PT})$ $= 45\ \mu\text{A} + 0.1 \times (8 + 0.9 + 16 + 18\text{ mA})$ $= 45\ \mu\text{A} + 0.1 \times 42.9$ $= 45\ \mu\text{A} + 4.29\text{ mA}$ $= \mathbf{4.34\text{ mA}}$ | |
| This is the operating power with no EEPROM writes or Flash erases. Calculation is based on $I_{OUT} = 0\text{ mA}$. | |



AC/DC
Parameters
(cont.)

Example of PSD813F1 Typical Power Calculation at $V_{CC} = 5.0\text{ V}$

| Conditions | |
|--|---------------------------------------|
| Highest Composite PLD input frequency (Freq PLD) | = 8 MHz |
| MCU ALE frequency (Freq ALE) | = 4 MHz |
| % Flash Access | = 80% |
| % SRAM access | = 15% |
| % I/O access | = 5% (no additional power above base) |
| Operational Modes | |
| % Normal | = 10% |
| % Power Down Mode | = 90% |
| Number of product terms used (from fitter report) | |
| | = 45 PT |
| % of total product terms | = 45/182 = 24.7% |
| Turbo Mode | = Off |
| Calculation (typical numbers used) | |
| $I_{CC\ total} = I_{pwrdown} \times \%pwrdown + \%normal \times (I_{CC\ (ac)} + I_{CC\ (dc)})$ $= I_{pwrdown} \times \%pwrdown + \%normal \times (\%flash \times 2.5\text{ mA/MHz} \times \text{Freq ALE} + \%SRAM \times 1.5\text{ mA/MHz} \times \text{Freq ALE} + \%PLD \times (\text{from graph using Freq PLD}))$ $= 50\ \mu\text{A} \times 0.90 + 0.1 \times (0.8 \times 2.5\text{ mA/MHz} \times 4\text{ MHz} + 0.15 \times 1.5\text{ mA/MHz} \times 4\text{ MHz} + 24\text{ mA})$ $= 45\ \mu\text{A} + 0.1 \times (8 + 0.9 + 24)$ $= 45\ \mu\text{A} + 0.1 \times 32.9$ $= 45\ \mu\text{A} + 3.29\text{ mA}$ $= \mathbf{3.34\text{ mA}}$ | |
| <p>This is the operating power with no EEPROM writes or Flash erases. Calculation is based on $I_{OUT} = 0\text{ mA}$.</p> | |

PSD813F1 DC Characteristics (5 V \pm 10% Versions)

| Symbol | Parameter | Conditions | Min | Typ | Max | Unit | |
|----------------------------------|---|--|--|----------|------------------------|---------|------------|
| V _{CC} | Supply Voltage | All Speeds | 4.5 | 5 | 5.5 | V | |
| V _{IH} | High Level Input Voltage | 4.5 V < V _{CC} < 5.5 V | 2 | | V _{CC} +.5 | V | |
| V _{IL} | Low Level Input Voltage | 4.5 V < V _{CC} < 5.5 V | -.5 | | 0.8 | V | |
| V _{IH1} | Reset High Level Input Voltage | (Note 1) | .8 V _{CC} | | V _{CC} +.5 | V | |
| V _{IL1} | Reset Low Level Input Voltage | (Note 1) | -.5 | | .2 V _{CC} -.1 | V | |
| V _{HYS} | Reset Pin Hysteresis | | 0.3 | | | V | |
| V _{LKO} | V _{CC} Min for Flash Erase and Program | | 2.5 | | 4.2 | V | |
| V _{OL} | Output Low Voltage | I _{OL} = 20 μ A, V _{CC} = 4.5 V | | 0.01 | 0.1 | V | |
| | | I _{OL} = 8 mA, V _{CC} = 4.5 V | | 0.25 | 0.45 | V | |
| V _{OH} | Output High Voltage Except V _{STBY} On | I _{OH} = -20 μ A, V _{CC} = 4.5 V | 4.4 | 4.49 | | V | |
| | | I _{OH} = -2 mA, V _{CC} = 4.5 V | 2.4 | 3.9 | | V | |
| V _{OH1} | Output High Voltage V _{STBY} On | I _{OH1} = 1 μ A | V _{SBY} - 0.8 | | | V | |
| V _{SBY} | SRAM Standby Voltage | | 2.0 | | V _{CC} | V | |
| I _{SBY} | SRAM Standby Current (V _{STBY} Pin) | V _{CC} = 0 V | | 0.5 | 1 | μ A | |
| I _{IDLE} | Idle Current (V _{STBY} Pin) | V _{CC} > V _{SBY} | -0.1 | | 0.1 | μ A | |
| V _{DF} | SRAM Data Retention Voltage | Only on V _{STBY} | 2 | | | V | |
| I _{SB} | Standby Supply Current for Power Down Mode | CSI > V _{CC} - 0.3 V (Notes 2 and 3) | | 50 | 200 | μ A | |
| I _{LI} | Input Leakage Current | V _{SS} < V _{IN} < V _{CC} | -1 | \pm .1 | 1 | μ A | |
| I _{LO} | Output Leakage Current | 0.45 < V _{IN} < V _{CC} | -10 | \pm 5 | 10 | μ A | |
| I _{CC} (DC) (Note 5) | Operating Supply Current | ZPLD Only | ZPLD_TURBO = OFF, f = 0 MHz (Note 5) | | 0 | | mA |
| | | ZPLD Only | ZPLD_TURBO = ON, f = 0 MHz | | 400 | 700 | μ A/PT |
| | | Flash or EEPROM | During Flash or EEPROM, Write/Erase Only | | 15 | 30 | mA |
| | | | Read Only, f = 0 MHz | | 0 | 0 | mA |
| SRAM | f = 0 MHz | | 0 | 0 | mA | | |
| I _{CC} (AC) (Note 5) | ZPLD AC Adder | | Fig. 33 (Note 4) | | | | |
| | FLASH or EEPROM AC Adder | | | 2.5 | 3.5 | mA/MHz | |
| | SRAM AC Adder | | | 1.5 | 3.0 | mA/MHz | |

- NOTE:**
1. Reset input has hysteresis. V_{IL1} is valid at or below .2V_{CC} -.1. V_{IH1} is valid at or above .8V_{CC}.
 2. CSI deselected or internal Power Down mode is active.
 3. PLD is in non-turbo mode and none of the inputs are switching
 4. Refer to Figure 32 for PLD current calculation.
 5. I_{OUT} = 0 mA

CPLD Combinatorial Timing (5 V ± 10%)

| Symbol | Parameter | Conditions | -90 | | -12 | | -15 | | Fast PT Aloc | TURBO OFF* | Slew (Note 1) | Unit |
|-------------------|---|-------------------|-----|-----|-----|-----|-----|-----|--------------------|---------------|------------------|------|
| | | | Min | Max | Min | Max | Min | Max | | | | |
| t _{PD} | CPLD Input Pin/Feedback to CPLD Combinatorial Output | | | 25 | | 30 | | 32 | Add 2 | Add 10 | Sub 2 | ns |
| t _{EA} | CPLD Input to CPLD Output Enable | | | 26 | | 30 | | 32 | | Add 10 | Sub 2 | ns |
| t _{ER} | CPLD Input to CPLD Output Disable | | | 26 | | 30 | | 32 | | Add 10 | Sub 2 | ns |
| t _{ARP} | CPLD Register Clear or Preset Delay | | | 26 | | 30 | | 33 | | Add 10 | Sub 2 | ns |
| t _{ARPW} | CPLD Register Clear or Preset Pulse Width | | 20 | | 24 | | 29 | | | Add 10 | | ns |
| t _{ARD} | CPLD Array Delay | Any Micro↔Cell | | 16 | | 18 | | 22 | Add 2 | | | ns |

NOTE: 1. Fast Slew Rate output available on PA[3:0], PB[3:0], and PD[2:0].

*ZPSD versions only.

PSD813F1 AC/DC
Parameters –
CPLD Timing
Parameters
(5 V ± 10% Versions)

CPLD Micro↔Cell Synchronous Clock Mode Timing (5 V ± 10% Versions)

| Symbol | Parameter | Conditions | -90 | | -12 | | -15 | | Fast PT Aloc | TURBO OFF* | Slew (Note 1) | Unit |
|------------------|---|---|-----|-------|-----|-------|-----|-------|--------------------|---------------|------------------|------|
| | | | Min | Max | Min | Max | Min | Max | | | | |
| f _{MAX} | Maximum Frequency External Feedback | 1/(t _S +t _{CO}) | | 30.30 | | 26.3 | | 23.8 | | | | MHz |
| | Maximum Frequency Internal Feedback (f _{CNT}) | 1/(t _S +t _{CO} -10) | | 43.48 | | 35.7 | | 31.25 | | | | MHz |
| | Maximum Frequency Pipelined Data | 1/(t _{CH} +t _{CL}) | | 50.00 | | 41.67 | | 33.3 | | | | MHz |
| t _S | Input Setup Time | | 15 | | 18 | | 20 | | Add 2 | Add 10 | | ns |
| t _H | Input Hold Time | | 0 | | 0 | | 0 | | | | | ns |
| t _{CH} | Clock High Time | Clock Input | 10 | | 12 | | 15 | | | | | ns |
| t _{CL} | Clock Low Time | Clock Input | 10 | | 12 | | 15 | | | | | ns |
| t _{CO} | Clock to Output Delay | Clock Input | | 18 | | 20 | | 22 | | | Sub 2 | ns |
| t _{ARD} | CPLD Array Delay | Any Micro↔Cell | | 16 | | 18 | | 22 | Add 2 | | | ns |
| t _{MIN} | Minimum Clock Period | t _{CH} +t _{CL} (Note 2) | 20 | | 24 | | 30 | | | | | ns |

NOTES: 1. Fast Slew Rate output available on PA[3:0], PB[3:0], and PD[2:0].

2. CLKIN t_{CLCL} = t_{CH} + t_{CL}.

*ZPSD versions only.

CPLD Micro↔Cell Asynchronous Clock Mode Timing (5 V ± 10% Versions)

| Symbol | Parameter | Conditions | -90 | | -12 | | -15 | | PT Aloc | TURBO OFF* | Slew Rate | Unit |
|-------------------|--|---|-----|-------|-----|-------|-----|-------|------------|---------------|--------------|------|
| | | | Min | Max | Min | Max | Min | Max | | | | |
| f _{MAXA} | Maximum Frequency External Feedback | 1/(t _{SA} +t _{COA}) | | 26.32 | | 23.25 | | 20.4 | | | | MHz |
| | Maximum Frequency Internal Feedback (f _{CNTA}) | 1/(t _{SA} +t _{COA} -10) | | 35.71 | | 30.30 | | 25.64 | | | | MHz |
| | Maximum Frequency Pipelined Data | 1/(t _{CHA} +t _{CLA}) | | 41.67 | | 35.71 | | 33.3 | | | | MHz |
| t _{SA} | Input Setup Time | | 8 | | 10 | | 12 | | Add 2 | Add 10 | | ns |
| t _{HA} | Input Hold Time | | 12 | | 14 | | 14 | | | | | ns |
| t _{CHA} | Clock Input High Time | | 12 | | 14 | | 15 | | | Add 10 | | ns |
| t _{CLA} | Clock Input Low Time | | 12 | | 14 | | 15 | | | Add 10 | | ns |
| t _{COA} | Clock to Output Delay | | | 30 | | 33 | | 37 | | Add 10 | Sub 2 | ns |
| t _{ARDA} | CPLD Array Delay | Any Micro↔Cell | | 16 | | 18 | | 22 | Add 2 | | | ns |
| t _{MINA} | Minimum Clock Period | 1/f _{CNTA} | 28 | | 33 | | 39 | | | | | ns |

*ZPSD versions only.

PSD813F1 AC/DC
Parameters –
CPLD Timing
Parameters
(5 V ± 10% Versions)

Input Micro↔Cell Timing (5 V ± 10% Versions)

| Symbol | Parameter | Conditions | -90 | | -12 | | 15 | | PT Aloc | TURBO OFF* | Unit |
|------------------|----------------------------------|------------|-----|-----|-----|-----|-----|-----|------------|---------------|------|
| | | | Min | Max | Min | Max | Min | Max | | | |
| t _{IS} | Input Setup Time | (Note 1) | 0 | | 0 | | 0 | | | | ns |
| t _{IH} | Input Hold Time | (Note 1) | 20 | | 22 | | 26 | | | Add 10 | ns |
| t _{INH} | NIB Input High Time | (Note 1) | 12 | | 15 | | 18 | | | | ns |
| t _{INL} | NIB Input Low Time | (Note 1) | 12 | | 15 | | 18 | | | | ns |
| t _{INO} | NIB Input to Combinatorial Delay | (Note 1) | | 46 | | 50 | | 59 | Add 2 | Add 10 | ns |

NOTE: 1. Inputs from Port A, B, and C relative to register/latch clock from the PLD. ALE/AS latch timings refer to t_{AVLX} and t_{LXAX}.

*ZPSD versions only.

Microcontroller
Interface –
AC/DC
Parameters
(5V ± 10% Versions)

AC Symbols for PLD Timing.

Example: t_{AVLX} – Time from Address Valid to ALE Invalid.

Signal Letters

- A** – Address Input
- C** – CEout Output
- D** – Input Data
- E** – E Input
- G** – Internal WDOG_ON signal
- I** – Interrupt Input
- L** – ALE Input
- N** – Reset Input or Output
- P** – Port Signal Output
- Q** – Output Data
- R** – \overline{WR} , \overline{UDS} , \overline{LDS} , \overline{DS} , \overline{IORD} , \overline{PSEN} Inputs
- S** – Chip Select Input
- T** – R/W Input
- W** – Internal PDN Signal
- B** – Vstby Output
- M** – Output Micro \Leftrightarrow Cell

Signal Behavior

- t** – Time
- L** – Logic Level Low or ALE
- H** – Logic Level High
- V** – Valid
- X** – No Longer a Valid Logic Level
- Z** – Float
- PW** – Pulse Width

Microcontroller Interface – PSD813F1 AC/DC Parameters

(5V ± 10% Versions)

Read Timing (5 V ± 10% Versions)

| Symbol | Parameter | Conditions | -90 | | -12 | | -15 | | Turbo Off | Unit |
|-------------------|---|-----------------|-----|-----|-----|-----|-----|-----|-----------|------|
| | | | Min | Max | Min | Max | Min | Max | | |
| t _{LVLX} | ALE or AS Pulse Width | | 20 | | 22 | | 28 | | | ns |
| t _{AVLX} | Address Setup Time | (Note 3) | 6 | | 8 | | 10 | | | ns |
| t _{LXAX} | Address Hold Time | (Note 3) | 8 | | 9 | | 11 | | | ns |
| t _{AVQV} | Address Valid to Data Valid | (Notes 3 and 6) | | 90 | | 120 | | 150 | Add 10 | ns |
| t _{SLQV} | CS Valid to Data Valid | | | 100 | | 135 | | 150 | | ns |
| t _{RLQV} | \overline{RD} to Data Valid 8-Bit Bus | (Note 5) | | 32 | | 35 | | 40 | | ns |
| | \overline{RD} or \overline{PSEN} to Data Valid 8-Bit Bus, 8031, 80251 | (Note 2) | | 38 | | 42 | | 45 | | ns |
| t _{RHQX} | \overline{RD} Data Hold Time | (Note 1) | 0 | | 0 | | 0 | | | ns |
| t _{RLRH} | \overline{RD} Pulse Width | (Note 1) | 32 | | 35 | | 38 | | | ns |
| t _{RHQZ} | \overline{RD} to Data High-Z | (Note 1) | | 25 | | 29 | | 33 | | ns |
| t _{EHEL} | E Pulse Width | | 32 | | 36 | | 38 | | | ns |
| t _{THEH} | R/W Setup Time to Enable | | 10 | | 13 | | 18 | | | ns |
| t _{ELTL} | R/W Hold Time After Enable | | 0 | | 0 | | 0 | | | ns |
| t _{AVPV} | Address Input Valid to Address Output Delay | (Note 4) | | 25 | | 28 | | 32 | | ns |

- NOTES:**
1. \overline{RD} timing has the same timing as \overline{DS} , \overline{LDS} , \overline{UDS} , and \overline{PSEN} signals.
 2. \overline{RD} and \overline{PSEN} have the same timing.
 3. Any input used to select an internal PSD813F function.
 4. In multiplexed mode, latched addresses generated from ADIO delay to address output on any Port.
 5. \overline{RD} timing has the same timing as \overline{DS} , \overline{LDS} , and \overline{UDS} signals.
 6. In Turbo Off mode, add 10ns to t_{AVQV}.

Microcontroller Interface – PSD813F1 AC/DC Parameters

(5V ± 10% Versions)

Write, Erase and Program Timing (5 V ± 10% Versions)

| Symbol | Parameter | Conditions | -90 | | -12 | | -15 | | Unit |
|-------------|--|-----------------|-----|-----|-----|-----|-----|-----|------|
| | | | Min | Max | Min | Max | Min | Max | |
| t_{LVLX} | ALE or AS Pulse Width | | 20 | | 22 | | 28 | | |
| t_{AVLX} | Address Setup Time | (Note 1) | 6 | | 8 | | 10 | | ns |
| t_{LXAX} | Address Hold Time | (Note 1) | 8 | | 9 | | 11 | | ns |
| t_{AVWL} | Address Valid to Leading Edge of \overline{WR} | (Notes 1 and 3) | 15 | | 18 | | 20 | | ns |
| t_{SLWL} | \overline{CS} Valid to Leading Edge of \overline{WR} | (Note 3) | 15 | | 18 | | 20 | | ns |
| t_{DVWH} | \overline{WR} Data Setup Time | (Note 3) | 35 | | 40 | | 45 | | ns |
| t_{WHDX} | \overline{WR} Data Hold Time | (Note 3) | 5 | | 5 | | 5 | | ns |
| t_{WLWH} | \overline{WR} Pulse Width | (Note 3) | 35 | | 40 | | 45 | | ns |
| t_{WHAX1} | Trailing Edge of \overline{WR} to Address Invalid | (Note 3) | 8 | | 9 | | 10 | | ns |
| t_{WHAX2} | Trailing Edge of \overline{WR} to DPLD Address Input Invalid | (Notes 3 and 6) | 0 | | 0 | | 0 | | ns |
| t_{WHPV} | Trailing Edge of \overline{WR} to Port Output Valid Using I/O Port Data Register | (Note 3) | | 30 | | 35 | | 38 | ns |
| t_{WLMV} | \overline{WR} Valid to Port Output Valid Using Micro↔Cell Register Preset/Clear | (Notes 3 and 4) | | 55 | | 60 | | 65 | ns |
| t_{DVMV} | Data Valid to Port Output Valid Using Micro↔Cell Register Preset/Clear | (Notes 3 and 5) | | 55 | | 60 | | 65 | ns |
| t_{AVPV} | Address Input Valid to Address Output Delay | (Note 2) | | 25 | | 28 | | 30 | ns |

- NOTES:**
1. Any input used to select an internal PSD813F function.
 2. In multiplexed mode, latched addresses generated from ADIO delay to address output on any Port.
 3. \overline{WR} timing has the same timing as E, \overline{LDS} , \overline{UDS} , \overline{WRL} , and \overline{WRH} signals.
 4. Assuming data is stable before active write signal.
 5. Assuming write is active before data becomes valid.
 6. Address Hold Time for DPLD inputs that are used to generate chip selects for internal PSD memory.

Microcontroller Interface – PSD813F1 AC/DC Parameters

(5V ± 10% Versions)

Port A Peripheral Data Mode Read Timing (5 V ± 10%)

| Symbol | Parameter | Conditions | -90 | | -12 | | -15 | | Turbo Off | Unit |
|-----------------|---|-----------------|-----|-----|-----|-----|-----|-----|-----------|------|
| | | | Min | Max | Min | Max | Min | Max | | |
| $t_{AVQV (PA)}$ | Address Valid to Data Valid | (Note 3) | | 40 | | 45 | | 45 | Add 10 | ns |
| $t_{SLQV (PA)}$ | \overline{CS} Valid to Data Valid | | | 35 | | 40 | | 45 | Add 10 | ns |
| $t_{RLQV (PA)}$ | \overline{RD} to Data Valid | (Notes 1 and 4) | | 32 | | 35 | | 40 | | ns |
| | \overline{RD} to Data Valid 8031 Mode | | | 38 | | 42 | | 45 | | ns |
| $t_{DVQV (PA)}$ | Data In to Data Out Valid | | | 30 | | 35 | | 38 | | ns |
| $t_{QXRH (PA)}$ | \overline{RD} Data Hold Time | | 0 | | 0 | | 0 | | | ns |
| $t_{RLRH (PA)}$ | \overline{RD} Pulse Width | (Note 1) | 32 | | 35 | | 38 | | | ns |
| $t_{RHQZ (PA)}$ | \overline{RD} to Data High-Z | (Note 1) | | 25 | | 28 | | 30 | | ns |

Port A Peripheral Data Mode Write Timing (5 V ± 10%)

| Symbol | Parameter | Conditions | -90 | | -12 | | -15 | | Unit |
|-----------------|---|------------|-----|-----|-----|-----|-----|-----|------|
| | | | Min | Max | Min | Max | Min | Max | |
| $t_{WLQV (PA)}$ | \overline{WR} to Data Propagation Delay | (Note 2) | | 35 | | 38 | | 40 | ns |
| $t_{DVQV (PA)}$ | Data to Port A Data Propagation Delay | (Note 5) | | 30 | | 35 | | 38 | ns |
| $t_{WHQZ (PA)}$ | \overline{WR} Invalid to Port A Tri-state | (Note 2) | | 25 | | 30 | | 33 | ns |

- NOTES:**
- \overline{RD} timing has the same timing as \overline{DS} , \overline{LDS} , \overline{UDS} , and \overline{PSEN} (in 8031 combined mode) signals.
 - \overline{WR} timing has the same timing as \overline{E} , \overline{LDS} , \overline{UDS} , \overline{WRL} , and \overline{WRH} signals.
 - Any input used to select Port A Data Peripheral Mode.
 - Data is already stable on Port A.
 - Data stable on ADIO pins to data on Port A.

Microcontroller Interface – PSD813F1 AC/DC Parameters

(5V ± 10% Versions)

Power Down Timing (5 V ± 10%)

| Symbol | Parameter | Conditions | -90 | | -12 | | -15 | | Unit |
|------------|--|-------------------|--------------------------|-----|-----|-----|-----|-----|---------|
| | | | Min | Max | Min | Max | Min | Max | |
| t_{LVDV} | ALE Access Time from Power Down | | | 90 | | 120 | | 150 | ns |
| t_{CLWH} | Maximum Delay from APD Enable to Internal PDN Valid Signal | Using CLKIN Input | 15 * t_{CLCL} (Note 1) | | | | | | μ s |

NOTE: 1. t_{CLCL} is the CLKIN clock period.

V_{stbyon} Timing (5 V ± 10%)

| Symbol | Parameter | Conditions | Min | Typ | Max | Unit |
|------------|---|------------|-----|-----|-----|---------|
| t_{BVBH} | V_{stby} Detection to V_{stbyon} Output High | | | 20 | | μ s |
| t_{BXBL} | V_{stby} Off Detection to V_{stbyon} Output Low | | | 20 | | μ s |

Reset Timing (5 V ± 10%)

| Symbol | Parameter | Conditions | Min | Typ | Max | Unit |
|---------------|---|------------|-----|-----|-----|------|
| t_{NLNH} | Warm RESET Active Low Time (Note 1) | | 150 | | | ns |
| t_{OPR} | RESET High to Operational Device | | | | 120 | ns |
| $t_{NLNH-PO}$ | Power On Reset Active Low Time (Note 2) | | 1 | | | ms |

NOTE: 1. RESET will not reset Flash or EEPROM programming/erase cycles.
2. $t_{NLNH-PO}$ is 10 ms for devices manufactured before rev. A.

Microcontroller Interface – PSD813F1 AC/DC Parameters (5V ± 10% Versions)

Flash Program, Write and Erase Times (5 V ± 10%)

| Symbol | Parameter | Min | Typ | Max | Unit |
|--------------------|---|---------|-----|------|--------|
| | Flash Program | | 8.5 | | sec |
| | Flash Bulk Erase (Preprogrammed) (Note 1) | | 3 | 30 | sec |
| | Flash Bulk Erase (Not Preprogrammed) | | 10 | | sec |
| t _{WHQV3} | Sector Erase (Preprogrammed) | | 1 | 30 | sec |
| t _{WHQV2} | Sector Erase (Not Preprogrammed) | | 2.2 | | sec |
| t _{WHQV1} | Byte Program | | 14 | 1200 | µs |
| | Program/Erase Cycles (Per Sector) | 100,000 | | | cycles |
| t _{WHWLO} | Sector Erase Time-Out | | 100 | | µs |
| t _{Q7VQV} | DQ7 Valid to Output (DQ7-0) Valid (Data Polling) (Note 2) | | | 30 | ns |

- NOTES:** 1. Programmed to all zeros before erase.
2. The Polling Status DQ7 is valid t_{Q7VQV} ns, before the data byte DQ0-7 is valid for reading.

EEPROM Write Times (5 V ± 10%)

| Symbol | Parameter | Min | Typ | Max | Unit |
|--------------------|--|--------|-----|-----|--------|
| t _{EEHWL} | Write Protect After Power Up | | 5 | | msec |
| t _{BLC} | EEPROM Byte Load Cycle Timing (Note 1) | 0.2 | | 120 | µsec |
| t _{WCB} | EEPROM Byte Write Cycle Time | | 4 | 10 | msec |
| t _{WCP} | EEPROM Page Write Cycle Time (Note 2) | | 6 | 30 | msec |
| | Program/Erase Cycles (Per Sector) | 10,000 | | | cycles |

- NOTES:** 1. If the maximum time has elapsed between successive writes to an EEPROM page, the transfer of this data to EEPROM cells will begin. Also, bytes cannot be written (loaded) to a page any faster than the indicated minimum type.
2. These specifications are for writing a page to EEPROM cells.

ISC Timing (5 V ± 10%)

| Symbol | Parameter | Conditions | -90 | | -12 | | -15 | | Unit |
|----------------------|---|------------|-----|-----|-----|-----|-----|-----|------|
| | | | Min | Max | Min | Max | Min | Max | |
| t _{ISCCF} | TCK Clock Frequency (except for PLD) | (Note 1) | | 18 | | 16 | | 14 | MHz |
| t _{ISCHH} | TCK Clock High Time | (Note 1) | 26 | | 29 | | 31 | | ns |
| t _{ISCLL} | TCK Clock Low Time | (Note 1) | 26 | | 29 | | 31 | | ns |
| t _{ISCCF-P} | TCK Clock Frequency (for PLD only) | (Note 2) | | 2 | | 2 | | 2 | MHz |
| t _{ISCHH-P} | TCK Clock High Time (for PLD only) | (Note 2) | 240 | | 240 | | 240 | | ns |
| t _{ISCLL-P} | TCK Clock Low Time (for PLD only) | (Note 2) | 240 | | 240 | | 240 | | ns |
| t _{ISCPSTU} | ISC Port Set Up Time | | 8 | | 10 | | 10 | | ns |
| t _{ISCPH} | ISC Port Hold Up Time | | 5 | | 5 | | 5 | | ns |
| t _{ISPCO} | ISC Port Clock to Output | | | 23 | | 24 | | 25 | ns |
| t _{ISCPZV} | ISC Port High-Impedance to Valid Output | | | 23 | | 24 | | 25 | ns |
| t _{ISCPVZ} | ISC Port Valid Output to High-Impedance | | | 23 | | 24 | | 25 | ns |

- NOTES:** 1. For “non-PLD” programming, erase or in ISC by-pass mode.
2. For program or erase PLD only.

PSD813F1V DC Characteristics (3.0 V to 3.6 V Versions)

| Symbol | Parameter | Conditions | Min | Typ | Max | Unit | |
|----------------------------------|---|---|---|------|-------------------------|------------|-------|
| V _{CC} | Supply Voltage | All Speeds | 3.0 | | 3.6 | V | |
| V _{IH} | High Level Input Voltage | 3.0 V < V _{CC} < 3.6 V | .7 V _{CC} | | V _{CC} +.5 | V | |
| V _{IL} | Low Level Input Voltage | 3.0 V < V _{CC} < 3.6 V | -.5 | | 0.8 | V | |
| V _{IH1} | Reset High Level Input Voltage | (Note 1) | .8 V _{CC} | | V _{CC} +.5 | V | |
| V _{IL1} | Reset Low Level Input Voltage | (Note 1) | -.5 | | .2 V _{CC} - .1 | V | |
| V _{HYS} | Reset Pin Hysteresis | | 0.3 | | | V | |
| V _{LKO} | V _{CC} Min for Flash Erase and Program | | 1.5 | | 2.2 | V | |
| V _{OL} | Output Low Voltage | I _{OL} = 20 μA, V _{CC} = 3.0 V | | 0.01 | 0.1 | V | |
| | | I _{OL} = 4 mA, V _{CC} = 3.0 V | | 0.15 | 0.45 | V | |
| V _{OH} | Output High Voltage Except V _{STBY} On | I _{OH} = -20 μA, V _{CC} = 3.0 V | 2.9 | 2.99 | | V | |
| | | I _{OH} = -1 mA, V _{CC} = 3.0 V | 2.7 | 2.8 | | V | |
| V _{OH1} | Output High Voltage V _{STBY} On | I _{OH1} = 1 μA | V _{SBY} - 0.8 | | | V | |
| V _{SBY} | SRAM Standby Voltage | | 2.0 | | V _{CC} | V | |
| I _{SBY} | SRAM Standby Current | V _{CC} = 0 V | | 0.5 | 1 | μA | |
| I _{IDLE} | Idle Current (V _{STBY} Pin) | V _{CC} > V _{SBY} | -0.1 | | 0.1 | μA | |
| V _{DF} | SRAM Data Retention Voltage | Only on V _{STBY} | 2 | | | V | |
| I _{SB} | Standby Supply Current for Power Down Mode | $\overline{\text{CSI}} > V_{CC} - 0.3 \text{ V}$ (Note 2) | | 25 | 100 | μA | |
| I _{LI} | Input Leakage Current | V _{SS} < V _{IN} < V _{CC} | -1 | ±.1 | 1 | μA | |
| I _{LO} | Output Leakage Current | 0.45 < V _{IN} < V _{CC} | -10 | ±5 | 10 | μA | |
| I _{CC} (DC) (Note 3) | Operating Supply Current | ZPLD Only | ZPLD_TURBO = OFF, f = 0 MHz (Note 3) | | 0 | | mA |
| | | | ZPLD_TURBO = ON, f = 0 MHz | | 200 | 400 | μA/PT |
| | | FLASH or EEPROM | During FLASH or EEPROM Write/Erase Only | | 10 | 25 | mA |
| | | | Read Only, f = 0 MHz | | 0 | 0 | mA |
| SRAM | f = 0 MHz | | 0 | 0 | mA | | |
| I _{CC} (AC) (Note 3) | ZPLD AC Adder | | | | | Figure 34a | |
| | FLASH or EEPROM AC Adder | | | 1.5 | 2.0 | mA/MHz | |
| | SRAM AC Adder | | | 0.8 | 1.5 | mA/MHz | |

- NOTES:**
- Reset input has hysteresis. V_{IL1} is valid at or below .2V_{CC} - .1. V_{IH1} is valid at or above .8V_{CC}.
 - $\overline{\text{CSI}}$ deselected or internal PD is active.
 - I_{OUT} = 0 mA

PSD813F1V AC/DC Parameters – CPLD Timing Parameters

(3.0 V to 3.6 V Versions)

CPLD Combinatorial Timing (3.0 V to 3.6 V Versions)

| Symbol | Parameter | Conditions | -15 | | -20 | | PT Aloc | TURBO OFF* | Slew Rate (Note 1) | Unit |
|-------------------|--|----------------|-----|-----|-----|-----|------------|---------------|--------------------------|------|
| | | | Min | Max | Min | Max | | | | |
| t _{PD} | CPLD Input Pin/Feedback to CPLD Combinatorial Output | | | 48 | | 55 | Add 4 | Add 20 | Sub 6 | ns |
| t _{EA} | CPLD Input to CPLD Output Enable | | | 43 | | 50 | | Add 20 | Sub 6 | ns |
| t _{ER} | CPLD Input to CPLD Output Disable | | | 43 | | 50 | | Add 20 | Sub 6 | ns |
| t _{ARP} | CPLD Register Clear or Preset Delay | | | 48 | | 55 | | Add 20 | Sub 6 | ns |
| t _{ARPW} | CPLD Register Clear or Preset Pulse Width | | 30 | | 35 | | | Add 20 | | ns |
| t _{ARD} | CPLD Array Delay | Any Micro↔Cell | | 29 | | 33 | Add 4 | | | ns |

NOTE: 1. Fast Slew Rate output available on PA[3:0], PB[3:0], and PD[2:0].

*ZPSD versions only.

CPLD Micro↔Cell Synchronous Clock Mode Timing (3.0 V to 3.6 V Versions)

| Symbol | Parameter | Conditions | -15 | | -20 | | PT Aloc | TURBO OFF* | Slew Rate (Note 1) | Unit |
|------------------|---|---|-----|------|-----|------|------------|---------------|--------------------------|------|
| | | | Min | Max | Min | Max | | | | |
| f _{MAX} | Maximum Frequency External Feedback | 1/(t _S +t _{CO}) | | 17.8 | | 14.7 | | | | MHz |
| | Maximum Frequency Internal Feedback (f _{CNT}) | 1/(t _S +t _{CO} -10) | | 19.6 | | 17.2 | | | | MHz |
| | Maximum Frequency Pipelined Data | 1/(t _{CH} +t _{CL}) | | 33.3 | | 31.2 | | | | MHz |
| t _S | Input Setup Time | | 27 | | 35 | | Add 4 | Add 20 | | ns |
| t _H | Input Hold Time | | 0 | | 0 | | | | | ns |
| t _{CH} | Clock High Time | Clock Input | 15 | | 16 | | | | | ns |
| t _{CL} | Clock Low Time | Clock Input | 15 | | 16 | | | | | ns |
| t _{CO} | Clock to Output Delay | Clock Input | | 35 | | 39 | | | Sub 6 | ns |
| t _{ARD} | CPLD Array Delay | Any Micro↔Cell | | 29 | | 33 | Add 4 | | | ns |
| t _{MIN} | Minimum Clock Period | t _{CH} +t _{CL} (Note 2) | 29 | | 32 | | | | | ns |

NOTES: 1. Fast Slew Rate output available on PA[3:0], PB[3:0], and PD[2:0].2. CLKIN t_{CLCL} = t_{CH} + t_{CL}.

*ZPSD versions only.

PSD813F1V AC/DC Parameters – CPLD Timing Parameters

(3.0 V to 3.6 V Versions)

CPLD Micro↔Cell Asynchronous Clock Mode Timing (3.0 V to 3.6 V Versions)

| Symbol | Parameter | Conditions | -15 | | -20 | | PT Alloc | TURBO OFF* | Slew Rate | Unit |
|-------------------|--|---|-----|------|-----|------|----------|------------|-----------|------|
| | | | Min | Max | Min | Max | | | | |
| f _{MAXA} | Maximum Frequency External Feedback | 1/(t _{SA} +t _{COA}) | | 19.2 | | 16.9 | | | | MHz |
| | Maximum Frequency Internal Feedback (f _{CNTA}) | 1/(t _{SA} +t _{COA} -10) | | 23.8 | | 20.4 | | | | MHz |
| | Maximum Frequency Pipelined Data | 1/(t _{CHA} +t _{CLA}) | | 27 | | 24.4 | | | | MHz |
| t _{SA} | Input Setup Time | | 12 | | 13 | | Add 4 | Add 20 | | ns |
| t _{HA} | Input Hold Time | | 15 | | 17 | | | | | ns |
| t _{CHA} | Clock High Time | | 22 | | 25 | | | Add 20 | | ns |
| t _{CLA} | Clock Low Time | | 15 | | 16 | | | Add 20 | | ns |
| t _{COA} | Clock to Output Delay | | | 40 | | 46 | | Add 20 | Sub 6 | ns |
| t _{ARD} | CPLD Array Delay | Any Micro↔Cell | | 29 | | 33 | Add 4 | | | ns |
| t _{MINA} | Minimum Clock Period | 1/f _{CNTA} | 42 | | 49 | | | | | ns |

*ZPSD Versions Only.

Input Micro↔Cell Timing (3.0 V to 3.6 V Versions)

| Symbol | Parameter | Conditions | -15 | | -20 | | PT Alloc | TURBO OFF* | Unit |
|------------------|----------------------------------|------------|-----|-----|-----|-----|----------|------------|------|
| | | | Min | Max | Min | Max | | | |
| t _{IS} | Input Setup Time | (Note 1) | 0 | | 0 | | | | ns |
| t _{IH} | Input Hold Time | (Note 1) | 25 | | 30 | | | Add 20 | ns |
| t _{INH} | NIB Input High Time | (Note 1) | 13 | | 15 | | | | ns |
| t _{INL} | NIB Input Low Time | (Note 1) | 13 | | 15 | | | | ns |
| t _{INO} | NIB Input to Combinatorial Delay | (Note 1) | | 62 | | 70 | Add 4 | Add 20 | ns |

NOTE: 1. Inputs from Port A, B, and C relative to register/latch clock from the PLD. ALE latch timings refer to t_{AVLX} and t_{LXAX}.

*ZPSD Versions Only.

Microcontroller
Interface –
PSD813F1V
AC/DC
Parameters
(3.0 V to 3.6 V
Versions)

AC Symbols for PLD Timing.

Example: t_{AVLX} – Time from Address Valid to ALE Invalid.

Signal Letters

- A** – Address Input
- C** – CEout Output
- D** – Input Data
- E** – E Input
- G** – Internal WDOG_ON signal
- I** – Interrupt Input
- L** – ALE Input
- N** – Reset Input or Output
- P** – Port Signal Output
- Q** – Output Data
- R** – \overline{WR} , \overline{UDS} , \overline{LDS} , \overline{DS} , IORD, \overline{PSEN} Inputs
- S** – Chip Select Input
- T** – R/W Input
- W** – Internal PDN Signal
- B** – Vstby Output
- M** – Output Micro \leftrightarrow Cell

Signal Behavior

- t** – Time
- L** – Logic Level Low or ALE
- H** – Logic Level High
- V** – Valid
- X** – No Longer a Valid Logic Level
- Z** – Float
- PW** – Pulse Width

Microcontroller Interface – PSD813F1V AC/DC Parameters

(3.0 V to 3.6 V Versions)

Read Timing (3.0 V to 3.6 V Versions)

| Symbol | Parameter | Conditions | -15 | | -20 | | Turbo Off | Unit |
|------------|---|------------|-----|-----|-----|-----|-----------|------|
| | | | Min | Max | Min | Max | | |
| t_{LVLX} | ALE or AS Pulse Width | | 26 | | 30 | | | ns |
| t_{AVLX} | Address Setup Time | (Note 3) | 10 | | 12 | | | ns |
| t_{LXAX} | Address Hold Time | (Note 3) | 12 | | 14 | | | ns |
| t_{AVQV} | Address Valid to Data Valid (Notes 3 and 6) | | | 150 | | 200 | Add 20 | ns |
| t_{SLQV} | CS Valid to Data Valid | | | 150 | | 200 | | ns |
| t_{RLQV} | \overline{RD} to Data Valid 8-Bit Bus | (Note 5) | | 35 | | 40 | | ns |
| | \overline{RD} or \overline{PSEN} to Data Valid 8-Bit Bus, 8031, 80251 | (Note 2) | | 50 | | 55 | | ns |
| t_{RHQX} | \overline{RD} Data Hold Time | (Note 1) | 0 | | 0 | | | ns |
| t_{RLRH} | \overline{RD} Pulse Width (also \overline{DS} , \overline{LDS} , \overline{UDS}) | | 40 | | 45 | | | ns |
| | \overline{RD} or \overline{PSEN} Pulse Width (8031, 80251) | | 55 | | 60 | | | ns |
| t_{RHQZ} | \overline{RD} to Data High-Z | (Note 1) | | 40 | | 45 | | ns |
| t_{EHEL} | E Pulse Width | | 45 | | 52 | | | ns |
| t_{THEH} | R/W Setup Time to Enable | | 18 | | 20 | | | ns |
| t_{ELTL} | R/W Hold Time After Enable | | 0 | | 0 | | | ns |
| t_{AVPV} | Address Input Valid to Address Output Delay | (Note 4) | | 35 | | 40 | | ns |

- NOTES:**
- \overline{RD} timing has the same timing as \overline{DS} , \overline{LDS} , \overline{UDS} , and \overline{PSEN} signals.
 - \overline{RD} and \overline{PSEN} have the same timing for 8031.
 - Any input used to select an internal PSD813F function.
 - In multiplexed mode latched address generated from ADIO delay to address output on any Port.
 - \overline{RD} timing has the same timing as \overline{DS} , \overline{LDS} , and \overline{UDS} signals.
 - In Turbo Off mode, add 20ns to t_{AVQV} .

Microcontroller Interface – PSD813F1V AC/DC Parameters (3.0 V to 3.6 V Versions)

Write, Erase and Program Timing (3.0 V to 3.6 V Versions)

| Symbol | Parameter | Conditions | -15 | | -20 | | Unit |
|-------------|---|-----------------|-----|-----|-----|-----|------|
| | | | Min | Max | Min | Max | |
| t_{LVLX} | ALE or AS Pulse Width | | 26 | | 30 | | |
| t_{AVLX} | Address Setup Time | (Note 1) | 10 | | 12 | | ns |
| t_{LXAX} | Address Hold Time | (Note 1) | 12 | | 14 | | ns |
| t_{AVWL} | Address Valid to Leading Edge of \overline{WR} | (Notes 1 and 3) | 20 | | 25 | | ns |
| t_{SLWL} | \overline{CS} Valid to Leading Edge of \overline{WR} | (Note 3) | 20 | | 25 | | ns |
| t_{DVWH} | \overline{WR} Data Setup Time | (Note 3) | 45 | | 50 | | ns |
| t_{WHDX} | \overline{WR} Data Hold Time | (Note 3) | 8 | | 10 | | ns |
| t_{WLWH} | \overline{WR} Pulse Width | (Note 3) | 48 | | 53 | | ns |
| t_{WHAX1} | Trailing Edge of \overline{WR} to Address Invalid | (Note 3) | 12 | | 17 | | ns |
| t_{WHAX2} | Trailing Edge of \overline{WR} to DPLD Address Input Invalid | (Notes 3 and 6) | 0 | | 0 | | ns |
| t_{WHPV} | Trailing Edge of \overline{WR} to Port Output Valid Using I/O Port Data Register | (Note 3) | | 45 | | 50 | ns |
| t_{WLMV} | \overline{WR} Valid to Port Output Valid Using Micro \leftrightarrow Cell Register Preset/Clear | (Notes 3 and 4) | | 90 | | 100 | ns |
| t_{DVMV} | Data Valid to Port Output Valid Using Micro \leftrightarrow Cell Register Preset/Clear | (Notes 3 and 5) | | 90 | | 100 | ns |
| t_{AVPV} | Address Input Valid to Address Output Delay | (Note 2) | | 48 | | 55 | ns |

- NOTES:**
- Any input used to select an internal PSD813F function.
 - In multiplexed mode, latched addresses generated from ADIO delay to address output on any Port.
 - \overline{WR} timing has the same timing as E, \overline{LDS} , \overline{UDS} , \overline{WRL} , and \overline{WRH} signals.
 - Assuming data is stable before active write signal.
 - Assuming write is active before data becomes valid.
 - Address Hold Time for DPLD inputs that are used to generate chip selects for internal PSD memory.

Microcontroller Interface – PSD813F1V AC/DC Parameters

(3.0 V to 3.6 V Versions)

Port A Peripheral Data Mode Read Timing (3.0 V to 3.6 V Versions)

| Symbol | Parameter | Conditions | -15 | | -20 | | Turbo Off | Unit |
|-----------------|---|-----------------|-----|-----|-----|-----|-----------|------|
| | | | Min | Max | Min | Max | | |
| $t_{AVQV (PA)}$ | Address Valid to Data Valid | (Note 3) | | 55 | | 60 | Add 20 | ns |
| $t_{SLQV (PA)}$ | \overline{CS} Valid to Data Valid | | | 45 | | 50 | Add 20 | ns |
| $t_{RLQV (PA)}$ | \overline{RD} to Data Valid | (Notes 1 and 4) | | 40 | | 45 | | ns |
| | \overline{RD} to Data Valid 8031 Mode | | | 45 | | 50 | | ns |
| $t_{DVQV (PA)}$ | Data In to Data Out Valid | | | 60 | | 65 | | ns |
| $t_{QXRH (PA)}$ | \overline{RD} Data Hold Time | | 0 | | 0 | | | ns |
| $t_{RLRH (PA)}$ | \overline{RD} Pulse Width | (Note 1) | 36 | | 46 | | | ns |
| $t_{RHQZ (PA)}$ | \overline{RD} to Data High-Z | (Note 1) | | 40 | | 45 | | ns |

Port A Peripheral Data Mode Write Timing (3.0 V to 3.6 V Versions)

| Symbol | Parameter | Conditions | -15 | | -20 | | Unit |
|-----------------|---|------------|-----|-----|-----|-----|------|
| | | | Min | Max | Min | Max | |
| $t_{WLQV (PA)}$ | \overline{WR} to Data Propagation Delay | (Note 2) | | 45 | | 55 | ns |
| $t_{DVQV (PA)}$ | Data to Port A Data Propagation Delay | (Note 5) | | 40 | | 45 | ns |
| $t_{WHQZ (PA)}$ | \overline{WR} Invalid to Port A Tri-state | (Note 2) | | 33 | | 35 | ns |

- NOTES:**
- \overline{RD} timing has the same timing as \overline{DS} , \overline{LDS} , \overline{UDS} , and \overline{PSEN} (in 8031 combined mode) signals.
 - \overline{WR} timing has the same timing as \overline{E} , \overline{LDS} , \overline{UDS} , \overline{WRL} , and \overline{WRH} signals.
 - Any input used to select Port A Data Peripheral Mode.
 - Data is already stable on Port A.
 - Data stable on ADIO pins to data on Port A.

Microcontroller Interface – PSD813F1V AC/DC Parameters (3.0 V to 3.6 V Versions)

Power Down Timing (3.0 V to 3.6 V Versions)

| Symbol | Parameter | Conditions | -15 | | -20 | | Unit |
|------------|--|-------------------|--------------------------|-----|-----|-----|---------|
| | | | Min | Max | Min | Max | |
| t_{LVDV} | ALE Access Time from Power Down | | | 150 | | 200 | ns |
| t_{CLWH} | Maximum Delay from APD Enable to Internal PDN Valid Signal | Using CLKIN Input | 15 * t_{CLCL} (Note 1) | | | | μ s |

NOTE: 1. t_{CLCL} is the CLKIN clock period.

V_{stbyon} Timing (3.0 V to 3.6 V Versions)

| Symbol | Parameter | Conditions | Min | Typ | Max | Unit |
|------------|---|------------|-----|-----|-----|---------|
| t_{BVBH} | V_{stby} Detection to V_{stbyon} Output High | | | 2.0 | | μ s |
| t_{BXBL} | V_{stby} Off Detection to V_{stbyon} Output Low | | | 2.0 | | μ s |

Reset Timing (3.0 V to 3.6 V Versions)

| Symbol | Parameter | Conditions | Min | Typ | Max | Unit |
|---------------|---|------------|-----|-----|-----|------|
| t_{NLNH} | Warm RESET Active Low Time (Note 1) | | 300 | | | ns |
| t_{OPR} | RESET High to Operational Device | | | | 300 | ns |
| $t_{NLNH-PO}$ | Power On Reset Active Low Time (Note 2) | | 1 | | | ms |

NOTE: 1. RESET will not reset Flash or EEPROM programming/erase cycles.
2. $t_{NLNH-PO}$ is 10 ms for devices manufactured before the rev. A.

Microcontroller Interface – PSD813F1V AC/DC Parameters (3.0 V to 3.6 V Versions)

Flash Program, Write and Erase Times (3.0 V to 3.6 V Versions)

| Symbol | Parameter | Min | Typ | Max | Unit |
|-------------|---|---------|-----|------|---------|
| | Flash Program | | 8.5 | | sec |
| | Flash Bulk Erase (Preprogrammed) (Note 1) | | 3 | 30 | sec |
| | Flash Bulk Erase (Not Preprogrammed) | | 10 | | sec |
| t_{WHQV3} | Sector Erase (Preprogrammed) | | 1 | 30 | sec |
| t_{WHQV2} | Sector Erase (Not Preprogrammed) | | 2.2 | | sec |
| t_{WHQV1} | Byte Program | | 14 | 1200 | μ s |
| | Program/Erase Cycles (Per Sector) | 100,000 | | | cycles |
| t_{WHWLO} | Sector Erase Time-Out | | 100 | | μ s |
| t_{Q7VQV} | DQ7 Valid to Output (DQ7-0) Valid (Data Polling) (Note 2) | | | 30 | ns |

NOTES: 1. Programmed to all zeros before erase.

2. The Polling Status DQ7 is valid t_{Q7VQV} ns before the data byte DQ0-7 is valid for reading.

EEPROM Write Times (3.0 V to 3.6 V Versions)

| Symbol | Parameter | Min | Typ | Max | Unit |
|-------------|--|--------|-----|-----|-----------|
| t_{EEHWL} | Write Protect After Power Up | | 5 | | msec |
| t_{BLC} | EEPROM Byte Load Cycle Timing (Note 1) | 0.2 | | 120 | μ sec |
| t_{WCB} | EEPROM Byte Write Cycle Time | | 4 | 10 | msec |
| t_{WCP} | EEPROM Page Write Cycle Time (Note 2) | | 6 | 30 | msec |
| | Program/Erase Cycles (Per Sector) | 10,000 | | | cycles |

NOTES: 1. If the maximum time has elapsed between successive writes to an EEPROM page, the transfer of this data to EEPROM cells will begin. Also, bytes cannot be written (loaded) to a page any faster than the indicated minimum type.

2. These specifications are for writing a page to EEPROM cells.

ISC Timing (3.0 V to 3.6 V Versions)

| Symbol | Parameter | Conditions | -15 | | -20 | | Unit |
|---------------|---|------------|-----|-----|-----|-----|------|
| | | | Min | Max | Min | Max | |
| t_{ISCCF} | TCK Clock Frequency (except for PLD) | (Note 1) | | 10 | | 9 | MHz |
| t_{ISCH} | TCK Clock High Time | (Note 1) | 45 | | 51 | | ns |
| t_{ISCL} | TCK Clock Low Time | (Note 1) | 45 | | 51 | | ns |
| $t_{ISCCF-P}$ | TCK Clock Frequency (for PLD only) | (Note 2) | | 2 | | 2 | MHz |
| t_{ISCH-P} | TCK Clock High Time (for PLD only) | (Note 2) | 240 | | 240 | | ns |
| t_{ISCL-P} | TCK Clock Low Time (for PLD only) | (Note 2) | 240 | | 240 | | ns |
| t_{ISCPUS} | ISC Port Set Up Time | | 13 | | 15 | | ns |
| t_{ISCPH} | ISC Port Hold Up Time | | 10 | | 10 | | ns |
| t_{ISPCO} | ISC Port Clock to Output | | | 36 | | 40 | ns |
| t_{ISCPZV} | ISC Port High-Impedance to Valid Output | | | 36 | | 40 | ns |
| t_{ISCPVZ} | ISC Port Valid Output to High-Impedance | | | 36 | | 40 | ns |

NOTES: 1. For “non-PLD” programming, erase or in ISC by-pass mode.

2. For program or erase PLD only.

Figure 34. Read Timing

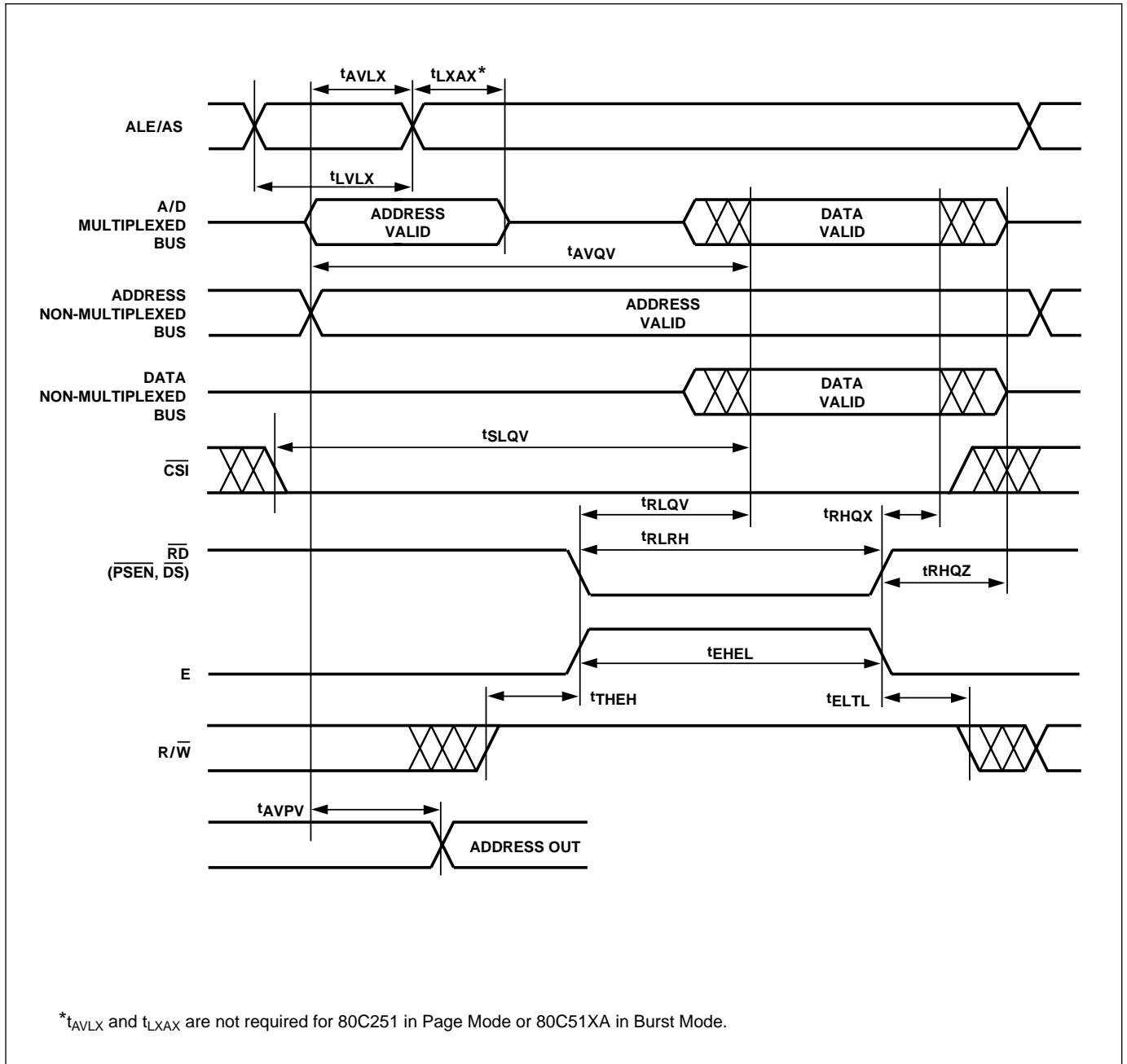


Figure 35. Write Timing

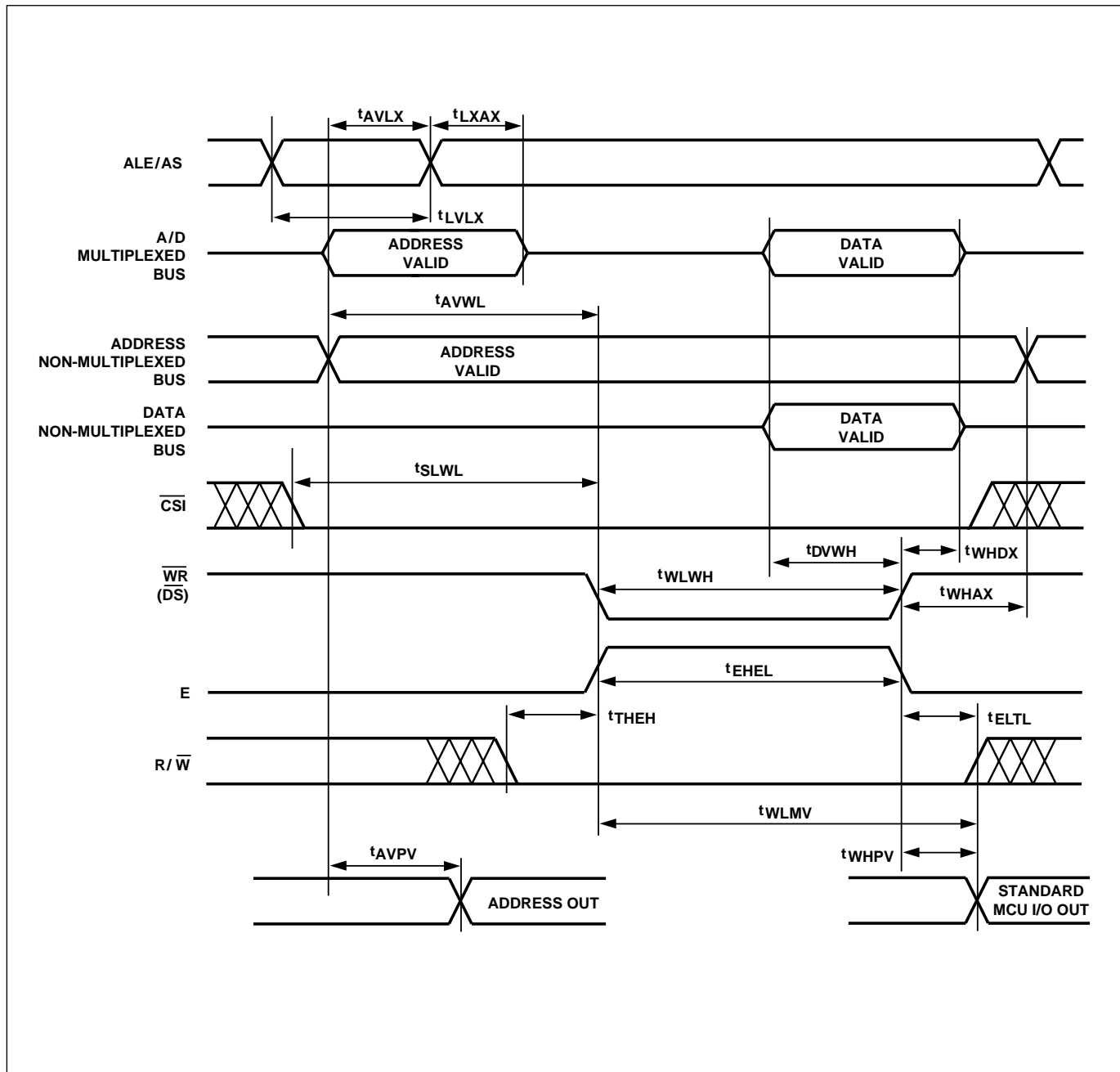


Figure 36. Peripheral I/O Read Timing

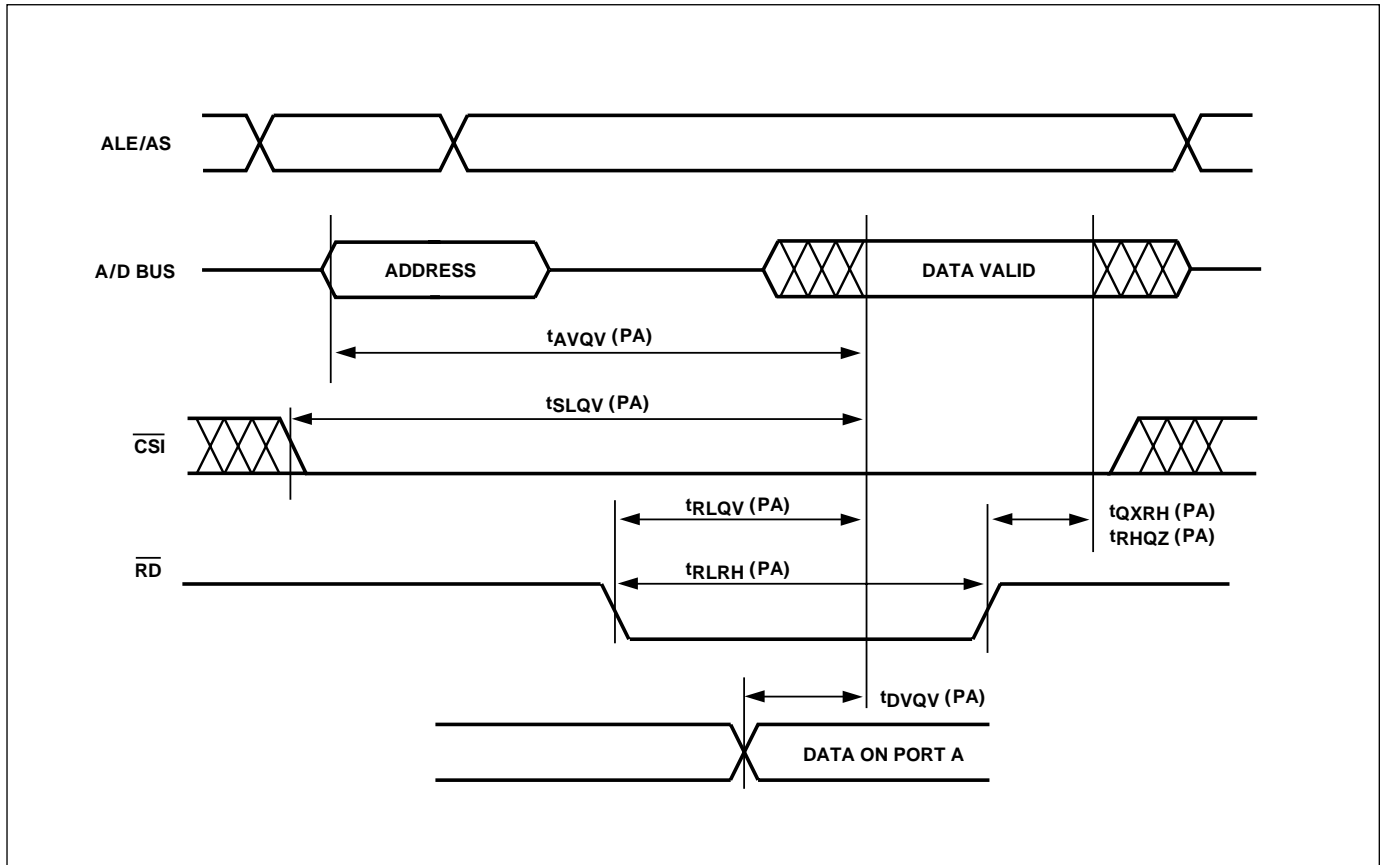


Figure 37. Peripheral I/O Write Timing

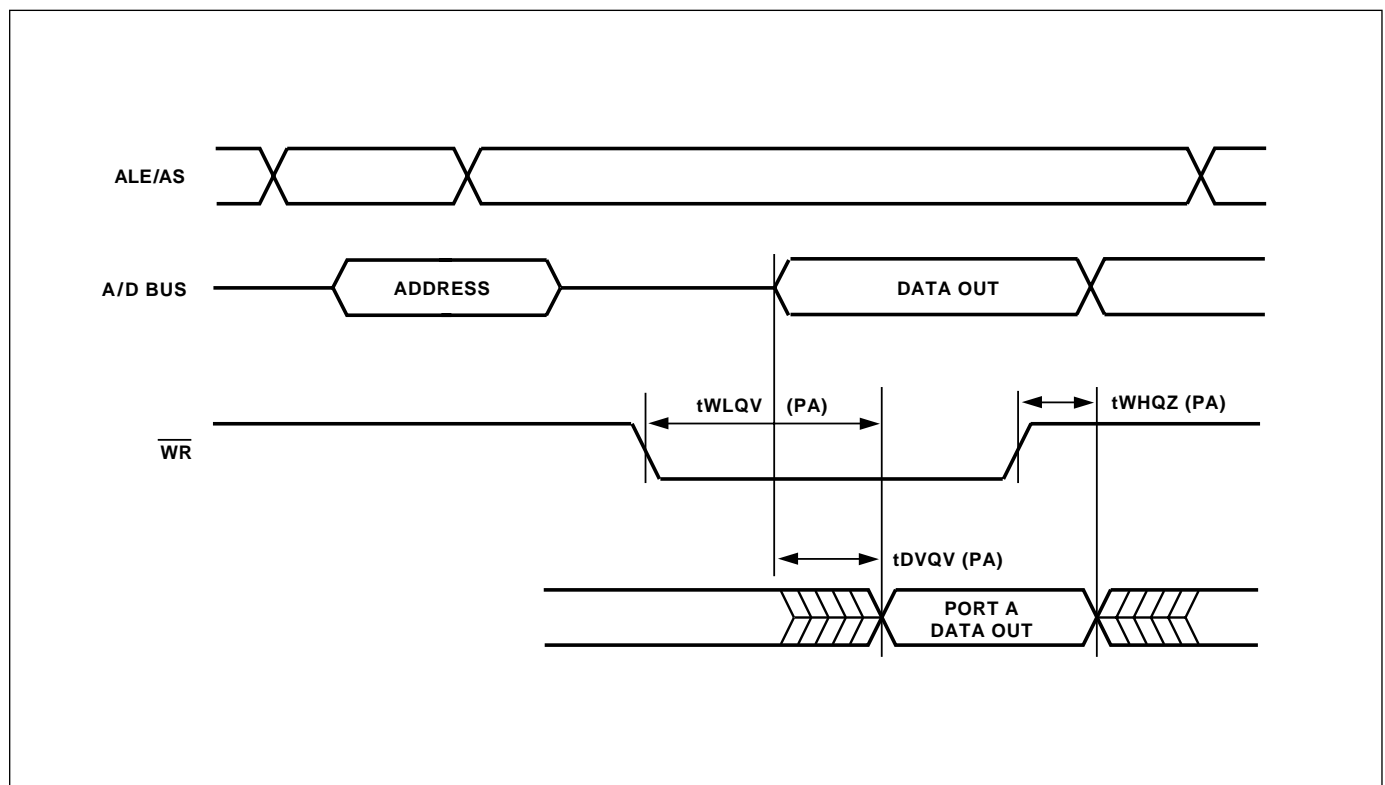


Figure 38. Combinatorial Timing – PLD

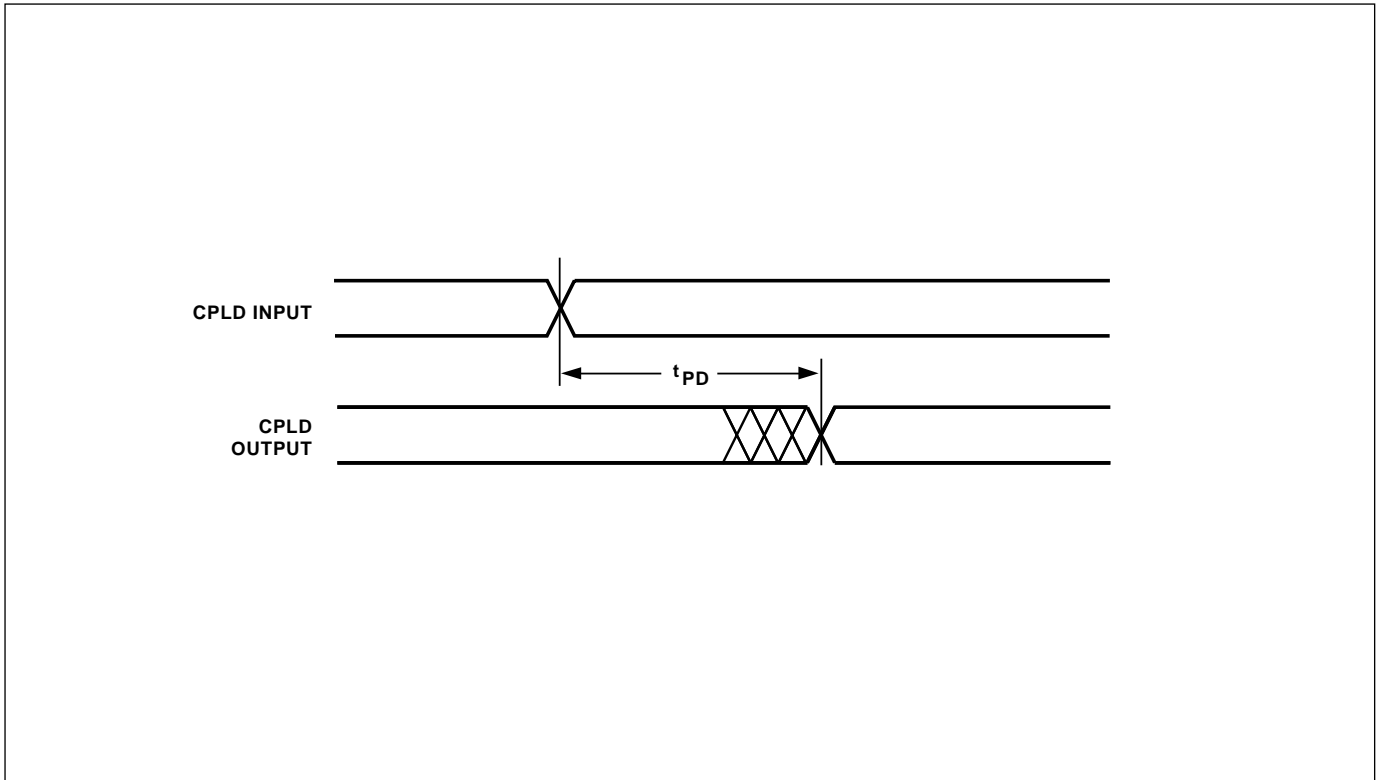


Figure 39. Synchronous Clock Mode Timing – PLD

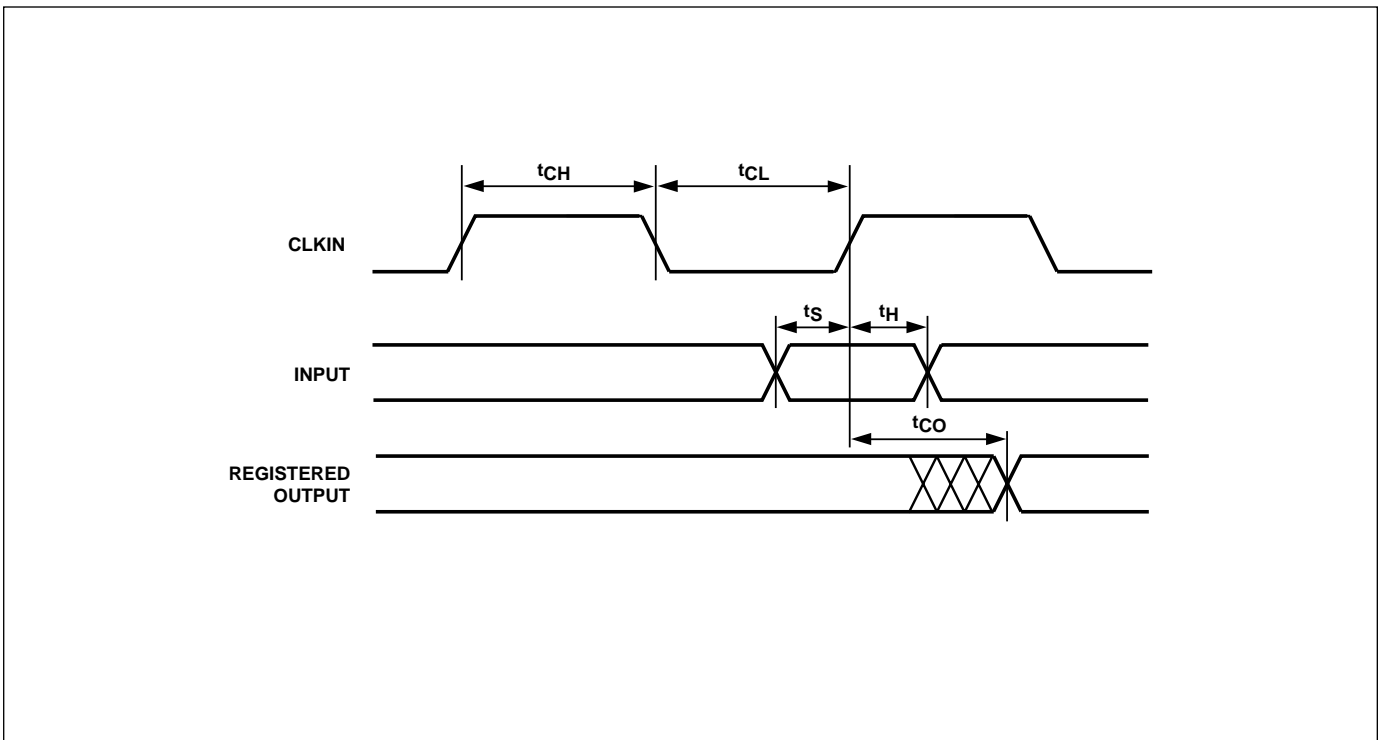


Figure 40. Asynchronous Clock Mode Timing (Product-Term Clock)

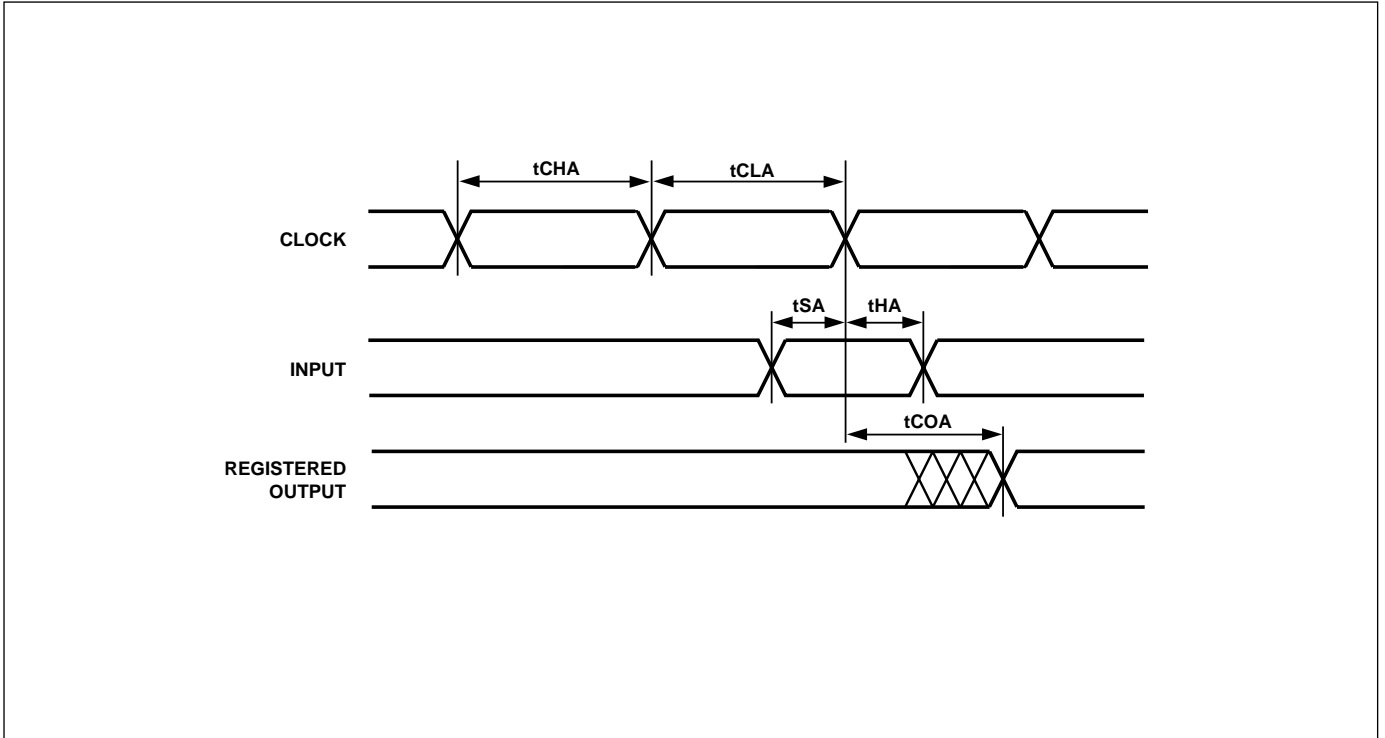


Figure 41. Input Micro↔Cell Timing (Product-Term Clock)

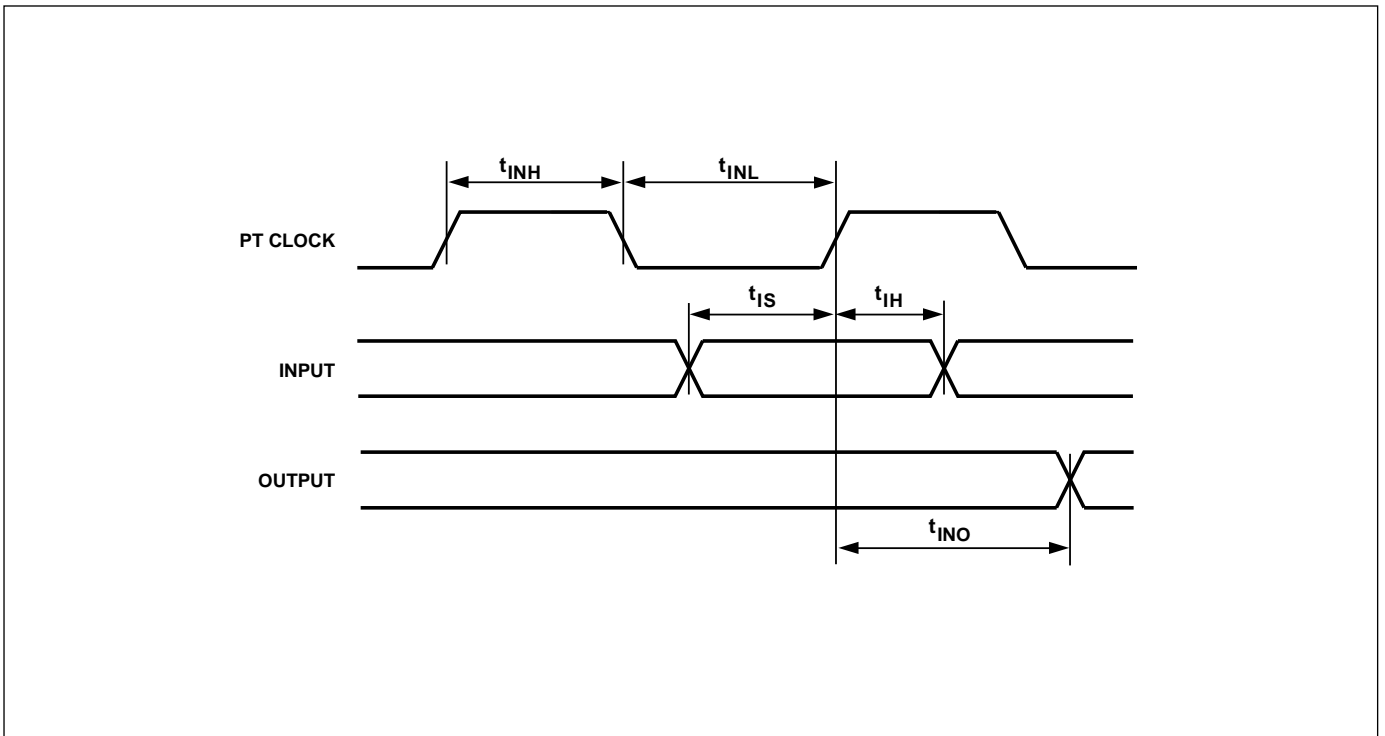


Figure 42. Input to Output Disable/Enable

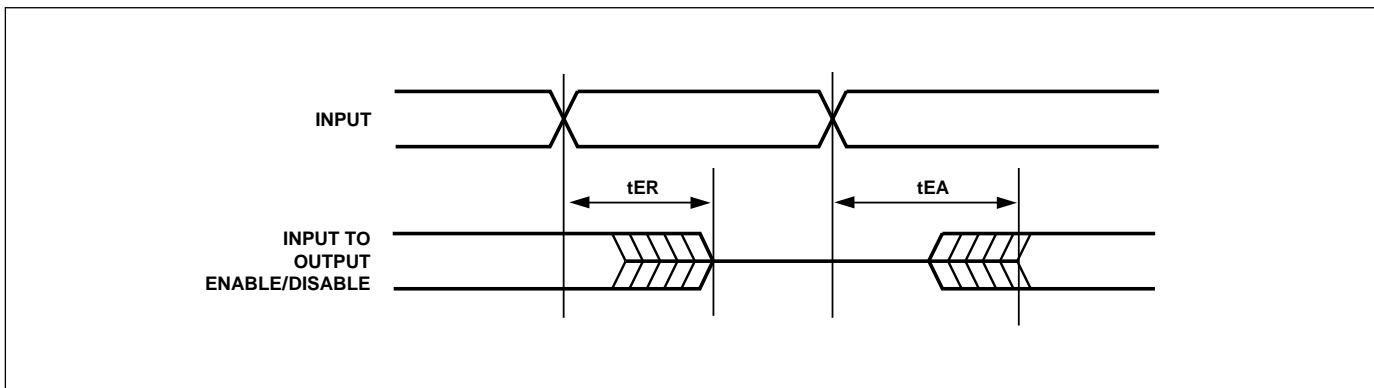


Figure 43. Asynchronous Reset/Preset

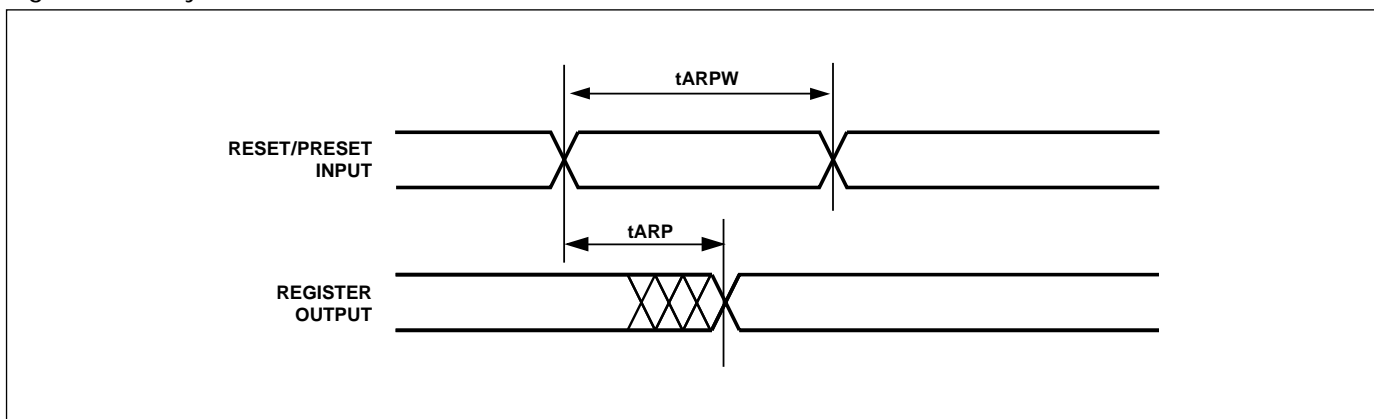


Figure 44. ISC Timing

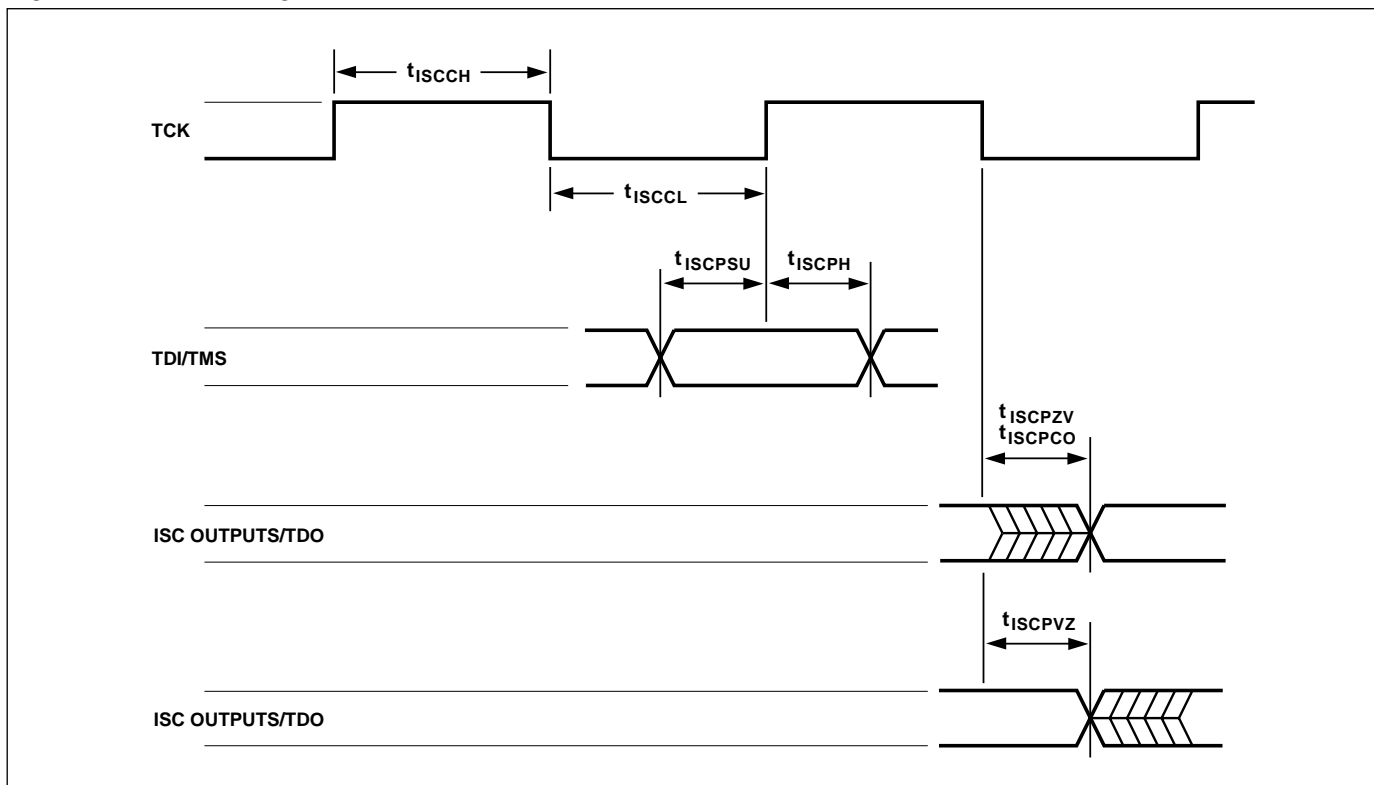


Figure 45. Reset Timing

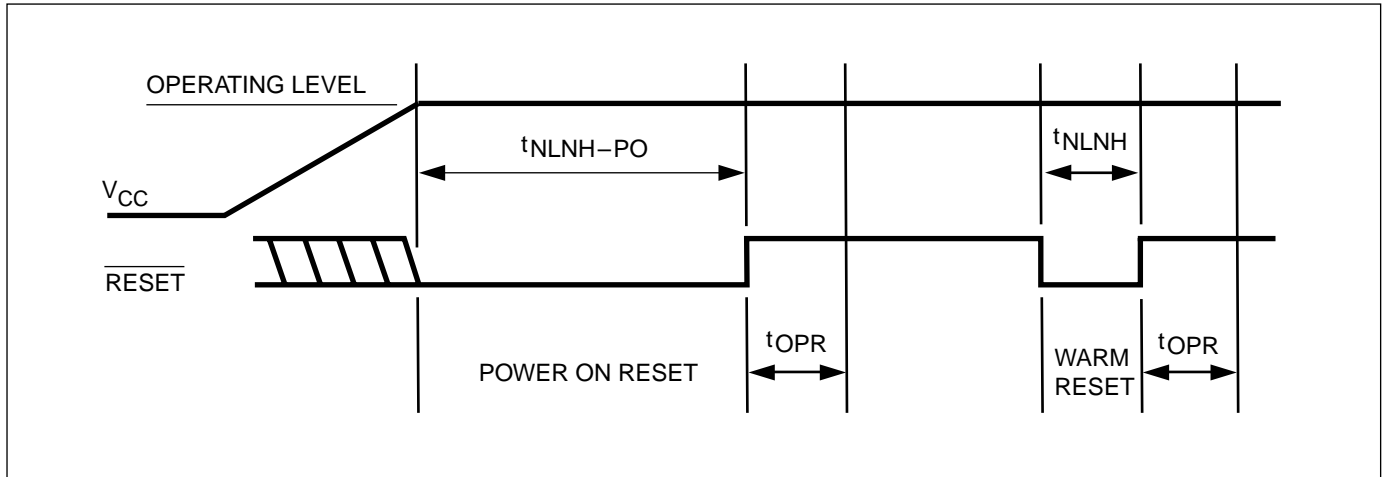


Figure 46. Key to Switching Waveforms

| WAVEFORMS | INPUTS | OUTPUTS |
|-----------|--------------------------|--------------------------------|
| | STEADY INPUT | STEADY OUTPUT |
| | MAY CHANGE FROM HI TO LO | WILL BE CHANGING FROM HI TO LO |
| | MAY CHANGE FROM LO TO HI | WILL BE CHANGING LO TO HI |
| | DON'T CARE | CHANGING, STATE UNKNOWN |
| | OUTPUTS ONLY | CENTER LINE IS TRI-STATE |

Pin Capacitance

$T_A = 25\text{ }^\circ\text{C}$, $f = 1\text{ MHz}$

| Symbol | Parameter ¹ | Conditions | Typical ² | Max | Unit |
|------------------|--|------------------------|----------------------|-----|------|
| C _{IN} | Capacitance (for input pins only) | V _{IN} = 0 V | 4 | 6 | pF |
| C _{OUT} | Capacitance (for input/output pins) | V _{OUT} = 0 V | 8 | 12 | pF |
| C _{VPP} | Capacitance (for CNTL2/V _{PP}) | V _{PP} = 0 V | 18 | 25 | pF |

NOTES: 1. These parameters are only sampled and are not 100% tested.
 2. Typical values are for T_A = 25°C and nominal supply voltages.

Figure 47.
AC Testing
Input/Output
Waveform

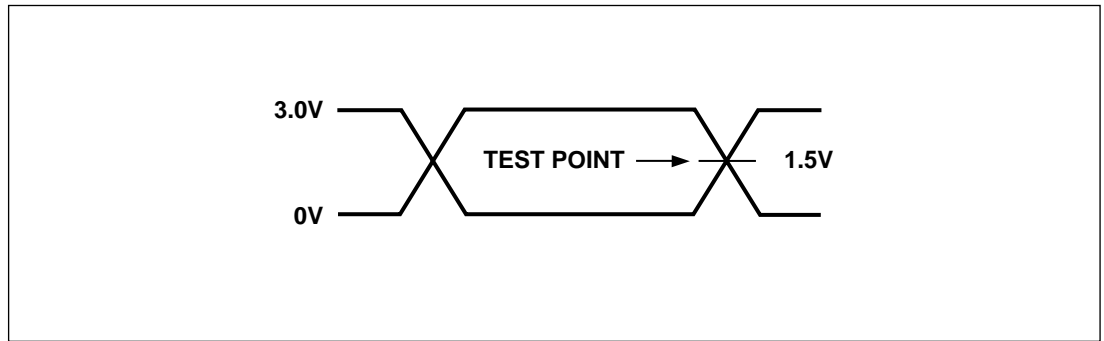
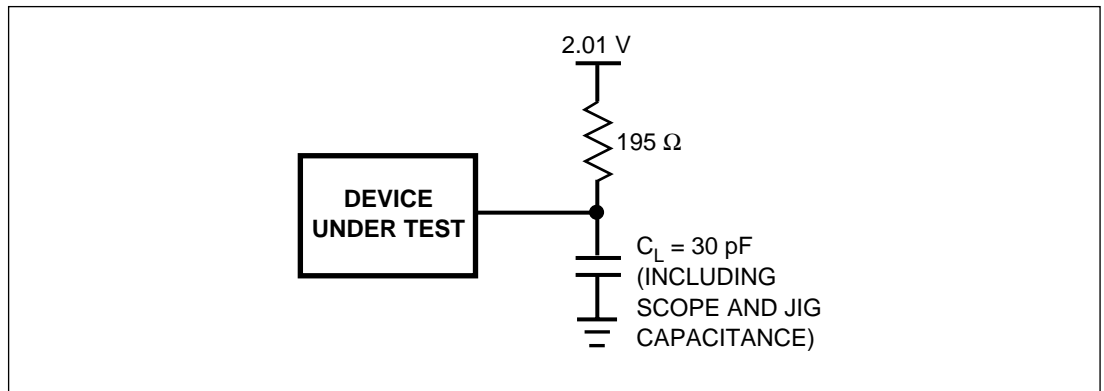


Figure 48.
AC Testing
Load Circuit



Programming

Upon delivery from ST, the PSD813F device has all bits in the PLDs and memories in the “1” or high state. The configuration bits are in the “0” or low state. The code, configuration, and PLDs logic are loaded through the procedure of programming.

Information for programming the device is available directly from ST. Please contact your local sales representative. (See the last page.)

PSD813F1-A
Pin
Assignments

52-Pin Plastic Leaded Chip Carrier (PLDCC) (Package Type J)

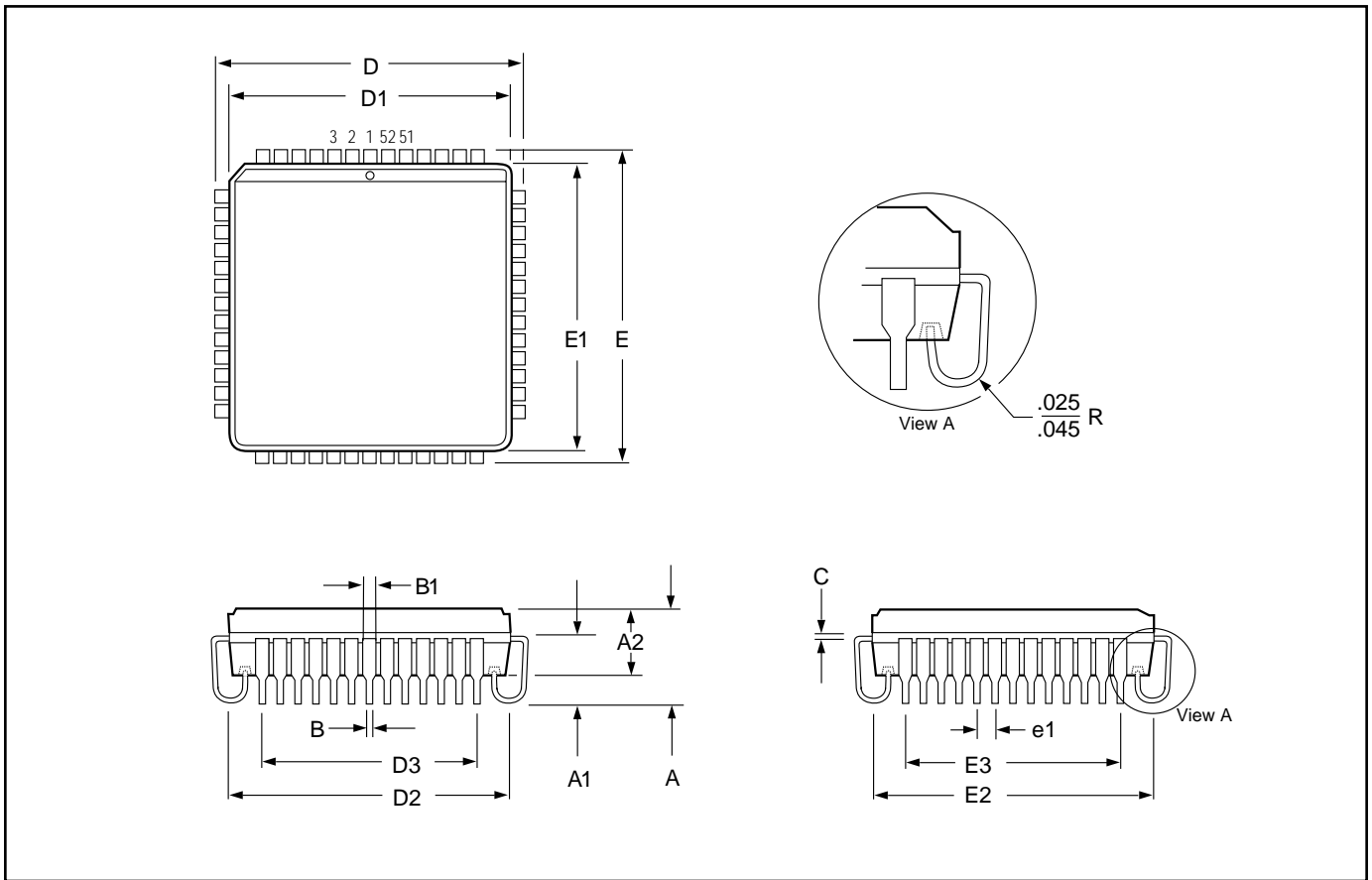
| Pin No. | Pin Assignments | Pin No. | Pin Assignments |
|---------|-----------------|---------|-----------------|
| 1 | GND | 27 | PA2 |
| 2 | PB5 | 28 | PA1 |
| 3 | PB4 | 29 | PA0 |
| 4 | PB3 | 30 | AD0 |
| 5 | PB2 | 31 | AD1 |
| 6 | PB1 | 32 | AD2 |
| 7 | PB0 | 33 | AD3 |
| 8 | PD2 | 34 | AD4 |
| 9 | PD1 | 35 | AD5 |
| 10 | PD0 | 36 | AD6 |
| 11 | PC7 | 37 | AD7 |
| 12 | PC6 | 38 | V _{CC} |
| 13 | PC5 | 39 | AD8 |
| 14 | PC4 | 40 | AD9 |
| 15 | V _{CC} | 41 | AD10 |
| 16 | GND | 42 | AD11 |
| 17 | PC3 | 43 | AD12 |
| 18 | PC2 (VSTBY) | 44 | AD13 |
| 19 | PC1 | 45 | AD14 |
| 20 | PC0 | 46 | AD15 |
| 21 | PA7 | 47 | CNTL0 |
| 22 | PA6 | 48 | RESET |
| 23 | PA5 | 49 | CNTL2 |
| 24 | PA4 | 50 | CNTL1 |
| 25 | PA3 | 51 | PB7 |
| 26 | GND | 52 | PB6 |

PSD813F1-A
Pin
Assignments
(cont.)

52-Pin Plastic Quad Flatpack (PQFP) (Package Type M)

| Pin No. | Pin Assignments | Pin No. | Pin Assignments |
|---------|-----------------|---------|-----------------|
| 1 | PD2 | 27 | AD4 |
| 2 | PD1 | 28 | AD5 |
| 3 | PD0 | 29 | AD6 |
| 4 | PC7 | 30 | AD7 |
| 5 | PC6 | 31 | VCC |
| 6 | PC5 | 32 | AD8 |
| 7 | PC4 | 33 | AD9 |
| 8 | VCC | 34 | AD10 |
| 9 | GND | 35 | AD11 |
| 10 | PC3 | 36 | AD12 |
| 11 | PC2 | 37 | AD13 |
| 12 | PC1 | 38 | AD14 |
| 13 | PC0 | 39 | AD15 |
| 14 | PA7 | 40 | CNTL0 |
| 15 | PA6 | 41 | <u>RESET</u> |
| 16 | PA5 | 42 | CNTL2 |
| 17 | PA4 | 43 | CNTL1 |
| 18 | PA3 | 44 | PB7 |
| 19 | GND | 45 | PB6 |
| 20 | PA2 | 46 | GND |
| 21 | PA1 | 47 | PB5 |
| 22 | PA0 | 48 | PB4 |
| 23 | AD0 | 49 | PB3 |
| 24 | AD1 | 50 | PB2 |
| 25 | AD2 | 51 | PB1 |
| 26 | AD3 | 52 | PB0 |

Figure 49A.
Drawing J7 – 52-Pin Plastic Leaded Chip Carrier (PLDCC) (Package Type J)



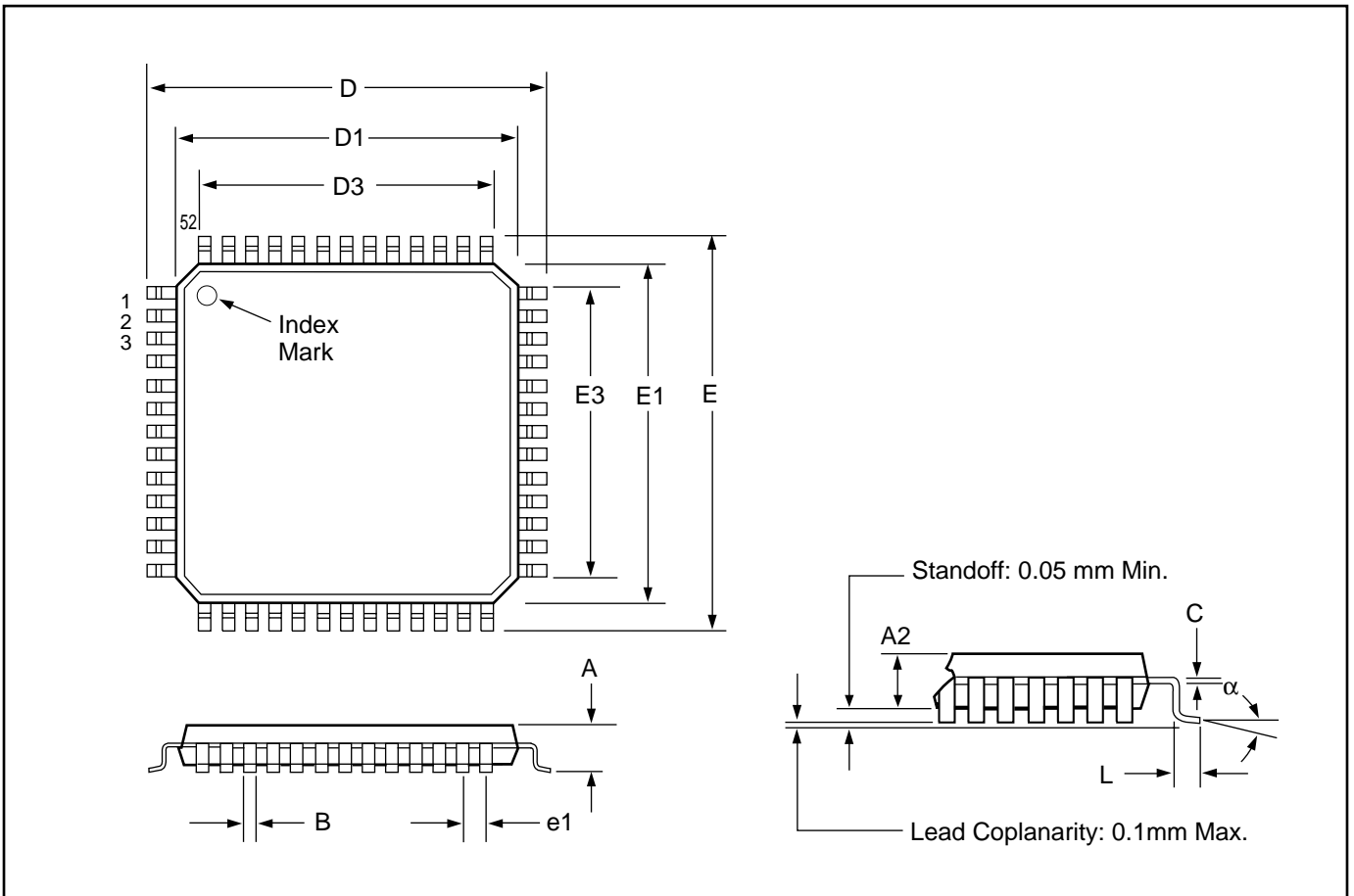
Family: Plastic Leaded Chip Carrier

| Symbol | Millimeters | | | Inches | | |
|--------|-------------|-------|-----------|--------|--------|-----------|
| | Min | Max | Notes | Min | Max | Notes |
| A | 4.19 | 4.57 | | 0.165 | 0.180 | |
| A1 | 2.54 | 2.79 | | 0.100 | 0.110 | |
| A2 | 3.66 | 3.86 | | 0.144 | 0.152 | |
| B | 0.33 | 0.53 | | 0.013 | 0.021 | |
| B1 | 0.66 | 0.81 | | 0.026 | 0.032 | |
| C | 0.246 | 0.261 | | 0.0097 | 0.0103 | |
| D | 19.94 | 20.19 | | 0.785 | 0.795 | |
| D1 | 19.05 | 19.15 | | 0.750 | 0.754 | |
| D2 | 17.53 | 18.54 | | 0.690 | 0.730 | |
| D3 | 15.24 | | Reference | 0.600 | | Reference |
| E | 19.94 | 20.19 | | 0.785 | 0.795 | |
| E1 | 19.05 | 19.15 | | 0.750 | 0.754 | |
| E2 | 17.53 | 18.54 | | 0.690 | 0.730 | |
| E3 | 15.24 | | Reference | 0.600 | | Reference |
| e1 | 1.27 | | Reference | 0.050 | | Reference |
| N | 52 | | | 52 | | |

020197R1



Figure 50A.
Drawing M3 – 52-Pin Plastic Quad Flatpack (PQFP) (Package Type M)



Family: Plastic Quad Flatpack (PQFP)

| Symbol | Millimeters | | | Inches | | |
|--------|-------------|-------|-----------|--------|-------|-----------|
| | Min | Max | Notes | Min | Max | Notes |
| α | 0° | 7° | | 0° | 7° | |
| A | – | 2.35 | | – | 0.093 | |
| A2 | 1.95 | 2.10 | | 0.077 | 0.083 | |
| B | 0.22 | 0.38 | Reference | 0.009 | 0.015 | |
| C | | 0.23 | | | 0.009 | |
| D | 12.95 | 13.45 | | 0.510 | 0.530 | |
| D1 | 9.90 | 10.10 | | 0.390 | 0.398 | |
| D3 | 7.80 | | Reference | 0.307 | | Reference |
| E | 12.95 | 13.45 | | 0.510 | 0.530 | |
| E1 | 9.90 | 10.10 | | 0.390 | 0.398 | |
| E3 | 7.80 | | Reference | 0.307 | | Reference |
| e1 | 0.65 | | Reference | 0.026 | | Reference |
| L | 0.73 | 1.03 | | 0.029 | 0.041 | |
| N | 52 | | | 52 | | |

060198R0

Selector Guide – PSD813F1-A

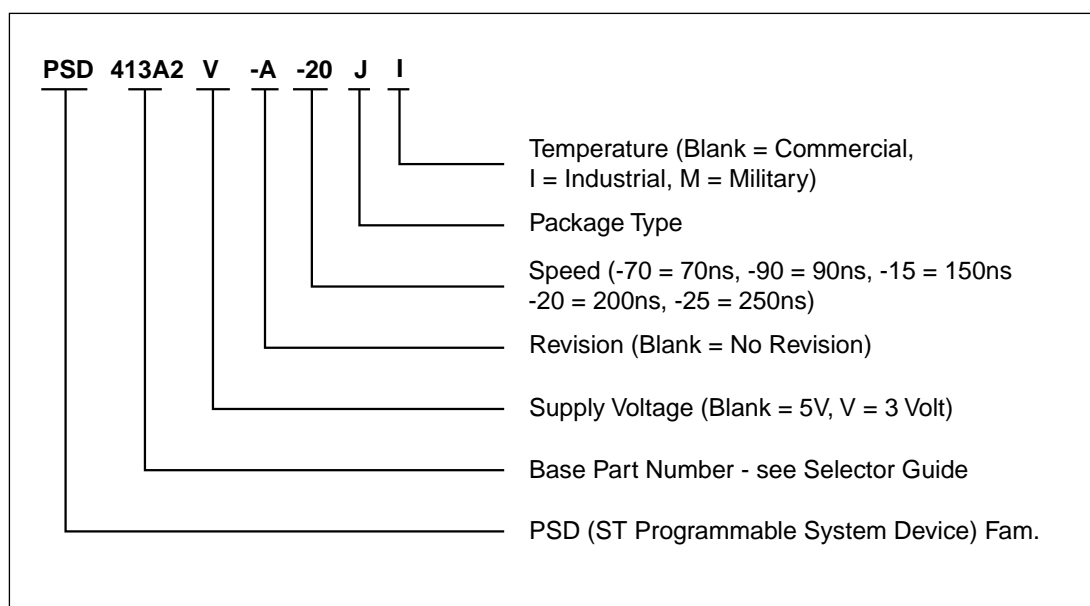
| Part # | | MCU | | PLDs/Decoders | | | | I/O | Memory | | | | Other | | | | | | | | | | | | |
|-----------------|-----------------|-----------|--------------------|---------------|----|----------|----|-------|---------------------|--------|--------------|-------|---|---|---|---|---|---|---|---|---|---|---|---|---|
| PSD @ 5 V | PSD @ 3 V | Data Path | | PLD Inputs | | | | Ports | Flash Program Store | | | | JTAG | | | | | | | | | | | | |
| | | Interface | Input Micro↔Cells | | | | 27 | | OTP EPROM Boot | | Parallel ISP | | X | | | | | | | | | | | | |
| | | | Output Micro↔Cells | | | | | | EEPROM/EEPROM Boot | | ISP Flash | | | | | | | | | | | | | | |
| | | | PLD Outputs | | | | | | 2nd Flash Boot | | ISP CPLD | | | | | | | | | | | | | | |
| | | | Page Reg. | | | | | | SRAM (w/BB) | | Periph. Mode | | | | | | | | | | | | | | |
| | | | | | | Security | | | | | | | | | | | | | | | | | | | |
| | | | | | | PMU | | | | | | | | | | | | | | | | | | | |
| | | | | | | APD | | | | | | | | | | | | | | | | | | | |
| PSD813F1 | PSD813F1V | 8 | PLUS1 | 73 | 24 | 16 | 19 | 8-Bit | 27 | 1024Kb | | 256Kb | 16Kb | X | X | X | X | X | X | X | X | X | X | X | X |
| PSD813F2 | PSD813F2V | 8 | PLUS1 | 73 | 24 | 16 | 19 | 8-Bit | 27 | 1024Kb | | 256Kb | 16Kb | X | X | X | X | X | X | X | X | X | X | X | X |
| PSD813F3 | PSD813F3V | 8 | PLUS1 | 73 | 24 | 16 | 19 | 8-Bit | 27 | 1024Kb | | | 16Kb | X | X | X | X | X | X | X | X | X | X | X | X |
| PSD813F4 | PSD813F4V | 8 | PLUS1 | 73 | 24 | 16 | 19 | 8-Bit | 27 | 1024Kb | | 256Kb | | X | X | X | X | X | X | X | X | X | X | X | X |
| PSD813F5 | PSD813F5V | 8 | PLUS1 | 73 | 24 | 16 | 19 | 8-Bit | 27 | 1024Kb | | | | X | X | X | X | X | X | X | X | X | X | X | X |

Legend:

- ZPSD = Zero Power version available at 4.5 V to 5.5 V V_{CC} (Example: ZPSD311-15J).
- ZPSDV = Zero Power version available at 2.7 V to 5.5 V V_{CC} (Example: ZPSD311V-25J). 2.7 V to 3.6 V V_{CC} on PSD8XXF family.
- STD = Standard MCU interfaces supported (Multiplexed and Non-Multiplexed).
- STD-M = Standard MCU interfaces supported (Multiplexed only).
- PLUS = New Intel 80C251 and Philips 80C51XA supported plus all standard MCUs.
- w/BB = Battery backed-up SRAM.
- APD = Automatic Power Down.



Part Number Construction



Ordering Information

| Part Number | Speed (ns) | Package Type | Operating Temperature Range |
|-------------------|------------|--------------|-----------------------------|
| PSD813F1-A-90J | 90 | 52 Pin PLDCC | Comm'l |
| PSD813F1-A-90JI | 90 | 52 Pin PLDCC | Industrial |
| PSD813F1-A-90M | 90 | 52 Pin PQFP | Comm'l |
| PSD813F1-A-90MI | 90 | 52 Pin PQFP | Industrial |
| PSD813F1-A-12JI | 120 | 52 Pin PLDCC | Industrial |
| PSD813F1-A-12MI | 120 | 52 Pin PQFP | Industrial |
| PSD813F1-A-V-15J | 150 | 52 Pin PLDCC | Comm'l |
| PSD813F1-A-V-15M | 150 | 52 Pin PQFP | Comm'l |
| PSD813F1-A-V-20JI | 200 | 52 Pin PLDCC | Industrial |
| PSD813F1-A-V-20MI | 200 | 52 Pin PQFP | Industrial |

REVISION HISTORY

Table 1. Document Revision History

| Date | Rev. | Description of Revision |
|-------------|-------------|--|
| Aug-2000 | 1.0 | Document written in the WSI format |
| 04-Jan-2002 | 1.1 | Front page, and back two pages, in ST format, added to the PDF file References to Waferscale, WSI, EasyFLASH and PSDsoft 2000 updated to ST, ST, Flash+PSD and PSDsoft Express |

Information furnished is believed to be accurate and reliable. However, STMicroelectronics assumes no responsibility for the consequences of use of such information nor for any infringement of patents or other rights of third parties which may result from its use. No license is granted by implication or otherwise under any patent or patent rights of STMicroelectronics. Specifications mentioned in this publication are subject to change without notice. This publication supersedes and replaces all information previously supplied. STMicroelectronics products are not authorized for use as critical components in life support devices or systems without express written approval of STMicroelectronics.

The ST logo is registered trademark of STMicroelectronics
All other names are the property of their respective owners

© 2002 STMicroelectronics - All Rights Reserved

STMicroelectronics group of companies Australia - Brazil - Canada - China - Finland - France - Germany - Hong Kong -
India - Israel - Italy - Japan - Malaysia - Malta - Morocco - Singapore - Spain - Sweden - Switzerland - United Kingdom - United States.

www.st.com