

PROTECTION PRODUCTS

PRELIMINARY

Description

The battery tracking TransClamp series of transient voltage suppressors (TVS) are designed to protect subscriber line interface circuits (SLIC) from transient voltages resulting from lightning strikes and AC power line disturbances. The TC03A-200 integrates all the components necessary to protect SLIC ICs from line to ground for positive and negative transients.

For negative transient events, the TVS thyristor will crowbar or "fire" when the line voltage exceeds the gate reference voltage. The gate voltage is referenced to the battery voltage ($-V_{BAT}$) plus the V_F of the series rectifier. The device firing voltage range is -5V to -100V. External diodes are used to shunt positive transients to ground.

These devices are designed to meet industry standard transient immunity requirements such as Bellcore TR-NWT-001089, FCC Part 68, ITU K17-K20, and IEC 61000-4-5. The high surge capability is advantageous in harsh environments, and offers better reliability than "low surge" rated devices. The integrated design saves board space and increases equipment reliability by replacing multiple discrete components. The device may be used to protect any SLIC and is particularly suited for those with integrated ring generators.

Features

- ◆ Transient protection for telecommunications lines to Bellcore 1089 (long haul), VDE 0433, ITU K20 IEC 61000-4-5 (Lightning), and FCC Part 68
- ◆ High surge current rating (100A, $t_p = 10/1000\mu s$)
- ◆ Protects up to two Tip & Ring line pairs
- ◆ Gate firing voltage is referenced to the system battery voltage
- ◆ Wide firing voltage range: -5V to -100V
- ◆ High holding current: 200mA
- ◆ Replaces discrete components
- ◆ Solid-state TVS process technology

Mechanical Characteristics

- ◆ JEDEC SOT-89 package
- ◆ Molding compound flammability rating: UL 94V-0
- ◆ Marking : Part number, date code, logo
- ◆ Packaging : Tape and Reel per EIA 481

Applications

- ◆ Subscriber Line Interface Circuit (SLIC) Protection
- ◆ Central Office Equipment
- ◆ ISDN Terminal Adaptors
- ◆ Cable Telephony
- ◆ Small Office Home Office (SOHO) Applications
- ◆ Wireless Local Loop (WLL)

Circuit Diagram

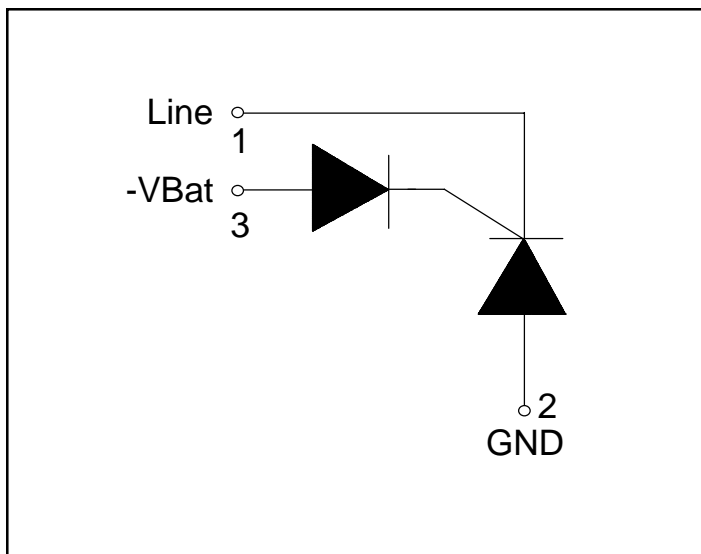

Schematic & PIN Configuration

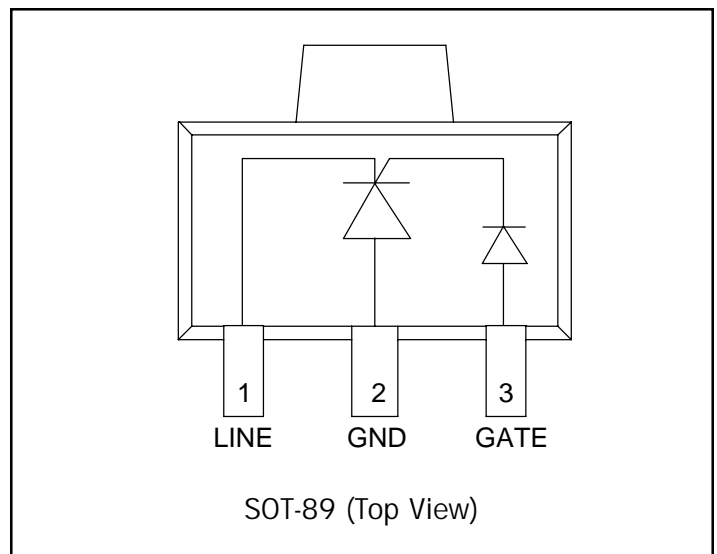

Absolute Maximum Rating

Rating	Symbol	Value	Units
Peak Pulse Current (tp = 10/1000μs)	I_{PP}	100	A
Peak Pulse Current (tp = 2/10μs)	I_{PP}	500	A
Continuous 60Hz Sinewave	I_{TSM}	60	A
Lead Soldering Temperature	T_L	260 (10 seconds)	°C
Operating Temperature	T_J	-55 to +125	°C
Storage Temperature	T_{STG}	-55 to +150	°C

Electrical Characteristics

TC03A-200						
Parameter	Symbol	Conditions	Minimum	Typical	Maximum	Units
Reverse Stand-Off Voltage	V_{DRM}	$T=25^{\circ}C$			-100	V
Switching Voltage	V_S	$I = I_S$		$-V_{BATT} - 5V$		V
Reverse Clamping Voltage	V_C	$I_{PP} = 1A, tp = 10/1000\mu s$			2	V
		$I_{PP} = 30A, tp = 10/1000\mu s$			3	V
		$I_{PP} = 100A, tp = 10/1000\mu s$			12	V
On-State Voltage	V_T	$I_T = 1A$			3	V
Reverse Leakage Current	I_{DRM}	$V_{DRM} = -100V, T=25^{\circ}C$			5	μA
Switching Current (Gate Triggering Current)	I_S	$T=25^{\circ}C$		60		mA
Holding Current	I_H	$T=25^{\circ}C$	-200	-220		mA
Continuous On-State Current	I_T	$T=25^{\circ}C$			1	A
Off-State Capacitance	C_{OFF}	Between I/O pins & Gnd $V_R = 0V, f = 1MHz$		100		pF
		Between I/O pins & Gnd $V_R = -50V, f = 1MHz$		50		pF

Typical Characteristics

Impulse Derating Curve

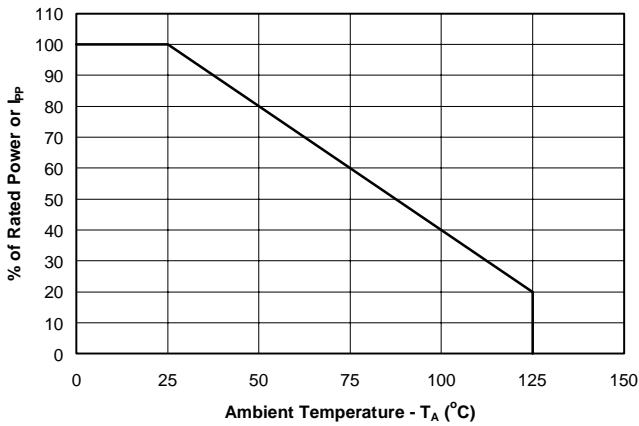

Normalized Holding Current vs. Temperature

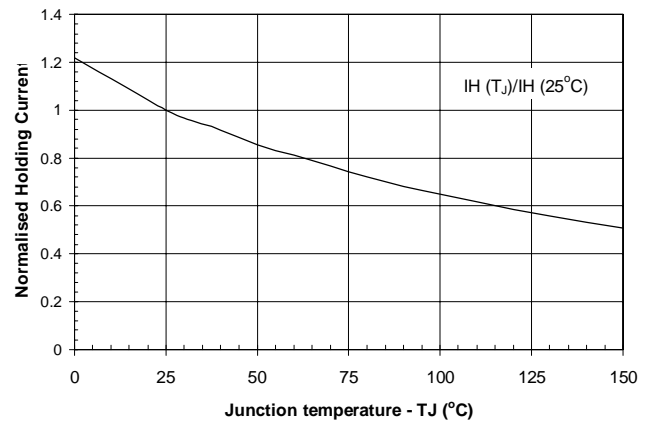

Reverse Leakage Current vs. temperature

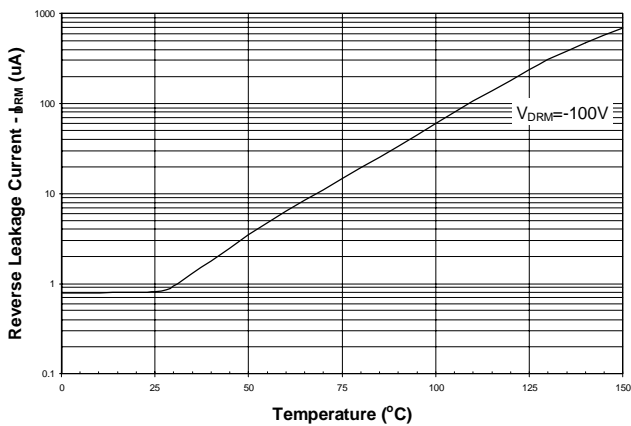

Normalized Gate Trigger Current vs. temperature

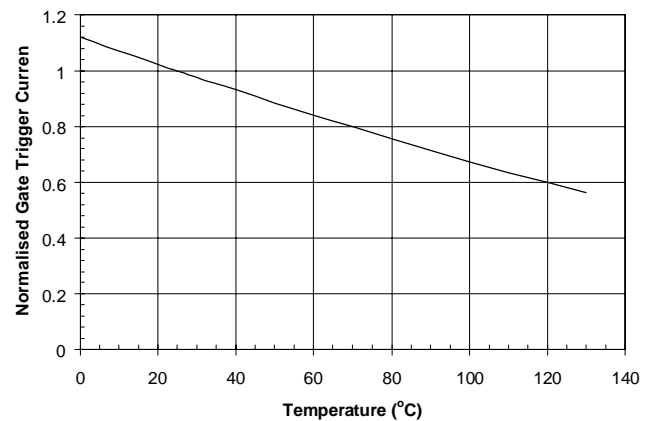

Diode Forward Voltage vs. Forward Current

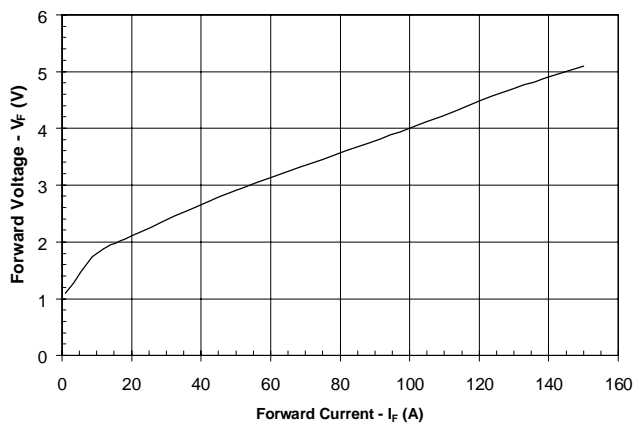

Impulse Response Characteristic

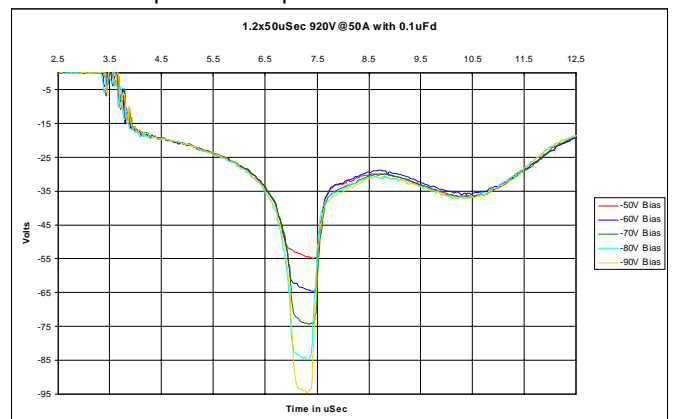

Applications Information

SLIC protection Concepts

Transient immunity standards require telecommunications equipment be surged in all of its operating states. This refers to the "on-hook" state (ring generator or ring detection monitoring) and the "off-hook" state (operational state). The On-Hook state must allow for operation of the normal battery voltage and ring voltage without interference. The Off-Hook state only allows for operation of the battery voltage plus operation signals.

Several SLIC types exist. The first type of SLIC requires an external ring relay to disconnect the SLIC and connect the ringing and trip bias power supply generating the ringing signal. Protection must be provided for the subsystem which includes the ringing relay and ringing source. This type of ringing is sometimes called unbalanced ringing. The ringing voltage is typically inserted on the Ring (B-lead), while the Tip (A-lead) is grounded. The SLIC may or may not be protected by the ringing subsystem protection. Separate subsystem protection may be needed and must have a minimum operating voltage that exceeds the battery voltage and the ring signal voltage. The SLIC IC is disconnected from the line and the ring generator and does not see the ringing voltages. Therefore, the protection element for the SLIC must only have a minimum operating voltage greater than the battery supply voltage. This device must suppress all transients above ground and below the battery voltage.

The second SLIC type has an integrated ring generation capability. The protection device described in this application information is particularly suited for use with this SLIC type. Unlike the unbalanced system described above, these SLIC devices generate a balanced ring signal between Tip & Ring. The voltage on either line falls between the battery voltage and ground. Therefore, the SLIC protection device can have an operating voltage that is very close to the battery voltage. Since battery voltages may vary between talk and ringing states, it is desirable to utilize a programmable protection device so that the voltage across the SLIC does not exceed the process limits and the stress on the device is minimized.

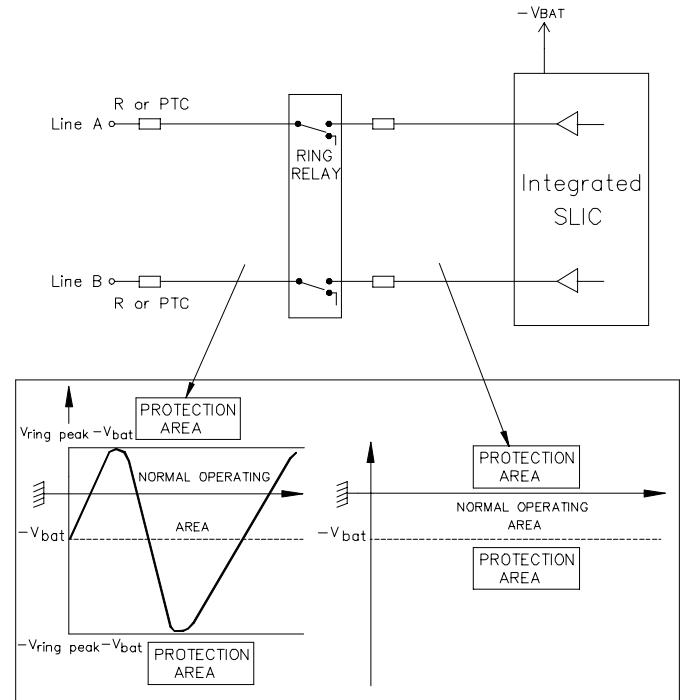
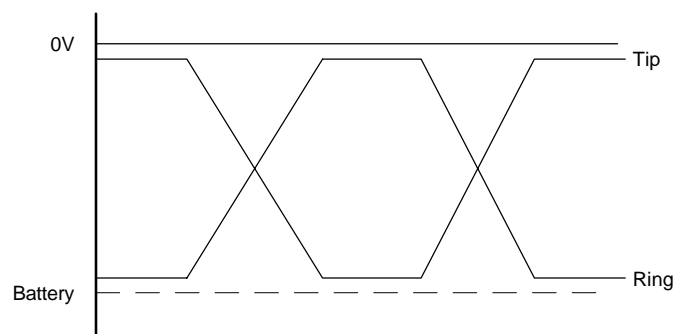
SLIC Operating Voltages (Unbalanced Ringing)

Balanced Ringing

Applications Information *(continued)*

Protecting One SLIC Line Pair

The TC03A-200 battery tracking TransClamp is specifically designed to protect subscriber line interface circuits (SLICs). The protection voltage of the device is referenced to the system's DC battery voltage. Therefore, the protection voltage will be essentially the same as the SLIC supply voltage, minimizing the stress on the protected device. The TC03A-200 may be referenced to battery voltages ranging from -5V to -100V. Pin 1 is connected to the line (A-lead or B-lead). The battery feed voltage source is connected to the gate of the internal SCR at pin 3. Pin 2 is connected to ground. A 0.1 μ F capacitor is recommended between the gate & ground to speed up the triggering of the device.

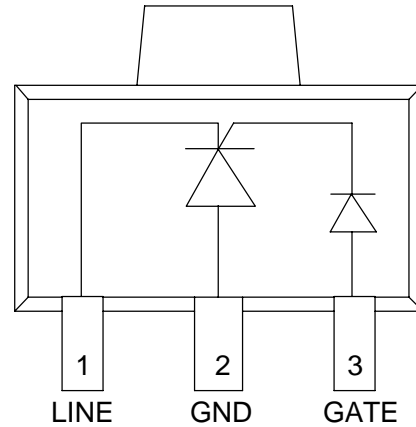
TC03 Connection Diagram



Protecting Multiple SLIC Lines

The TC03A-200 may be used in conjunction with steering diodes to protect up to two SLIC Tip & Ring line pairs. The steering diodes shunt positive surges to ground. In this configuration, each line pair may be surged to 100A (tp=10/100 μ s) independently, or all four pairs may be surged simultaneously up to 50A (tp=10/100 μ s). This provides the designer with a flexible, cost effective solution and increased reliability over low current protection schemes.

Typical Applications

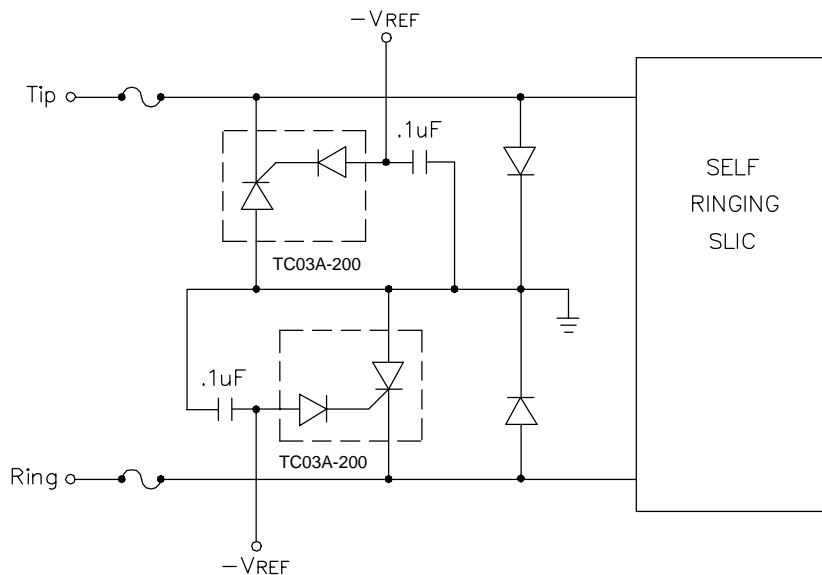

Protecting SLIC with Integrated Ring Generator

Typical Applications (continued)

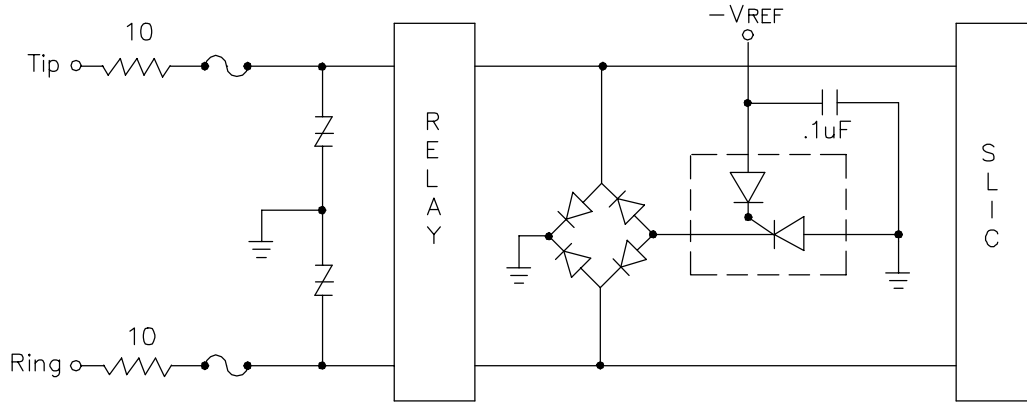

Protecting SLIC with External Ring Generator

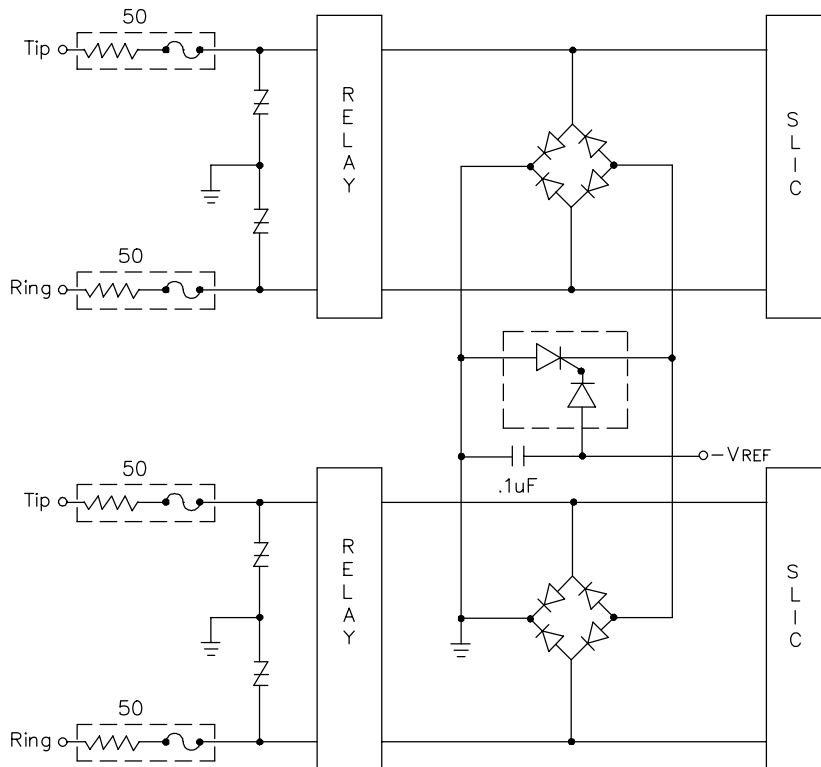

Protecting Multiple SLIC's with External Ring Generators

Outline Drawing - SOT-89

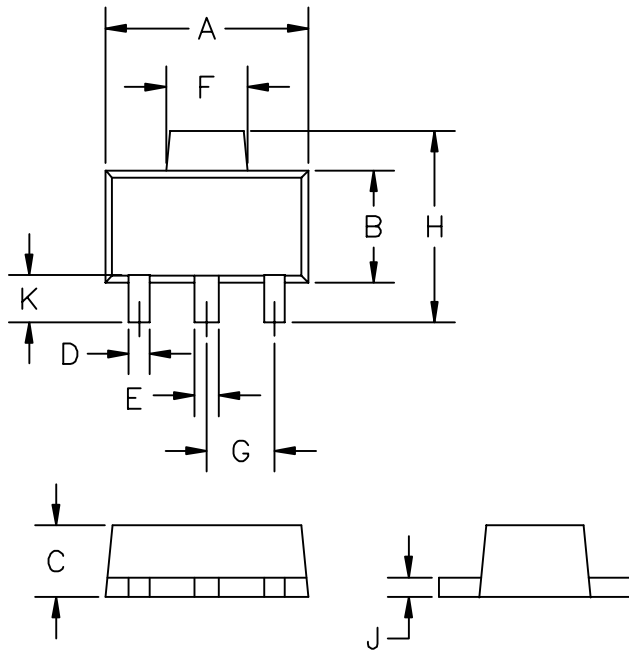

DIM ^N	INCHES		MM		NOTE
	MIN	MAX	MIN	MAX	
A	.173	.181	4.40	4.60	—
B	.090	.102	2.29	2.60	—
C	—	.063	—	1.60	—
D	.014	.019	.36	.48	—
E	.017	.022	.44	.56	—
F	.065	.070	1.65	1.78	—
G	.059	BSC	1.50	BSC	—
H	.155	.167	3.94	4.25	—
J	—	.017	—	.44	—
K	.035	.047	.89	1.20	—

Land Pattern - SOT-89

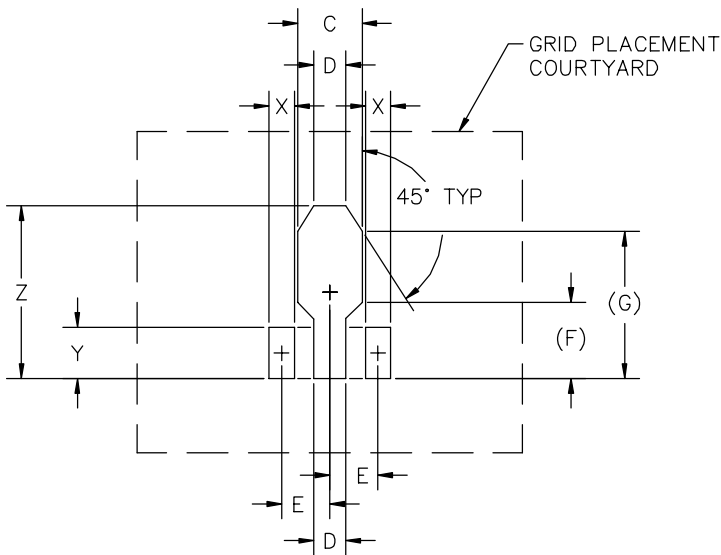

DIM ^N	INCHES		MM		NOTE
	MIN	MAX	MIN	MAX	
C	.071	.079	1.80	2.00	—
D	.031	.039	.80	1.00	—
E	.059	BSC	1.50	BSC	—
F	—	.094	—	2.40	REF
G	—	.181	—	4.60	REF
X	.024	.031	.60	.80	—
Y	.055	.063	1.40	1.60	—
Z	.205	.212	5.20	5.40	—

② GRID PLACEMENT COURTYARD IS 12 X 10 ELEMENTS (12mm X 10mm) IN ACCORDANCE WITH THE INTERNATIONAL GRID DETAILED IN IEC PUBLICATION 97.

① CONTROLLING DIMENSIONS: MILLIMETERS.

Ordering Information

Part Number	Holding Current	Qty per Reel	Reel Size
TC03A-200.TC	200mA	3000	7 Inch

Contact Information

Semtech Corporation
Protection Products Division
652 Mitchell Rd., Newbury Park, CA 91320
Phone: (805)498-2111 FAX (805)498-3804