

**Description**

- Extremely low collector-to-emitter saturation voltage  
(  $V_{CE(SAT)}=0.2V$  Typ. @  $I_C/I_B=3A/150mA$  )
- Suitable for low voltage large current drivers
- Switching Application

**Ordering Information**

Type NO.	Marking	Package Code
STD129	STD129	TO-92

**Outline Dimensions**

**unit : mm**

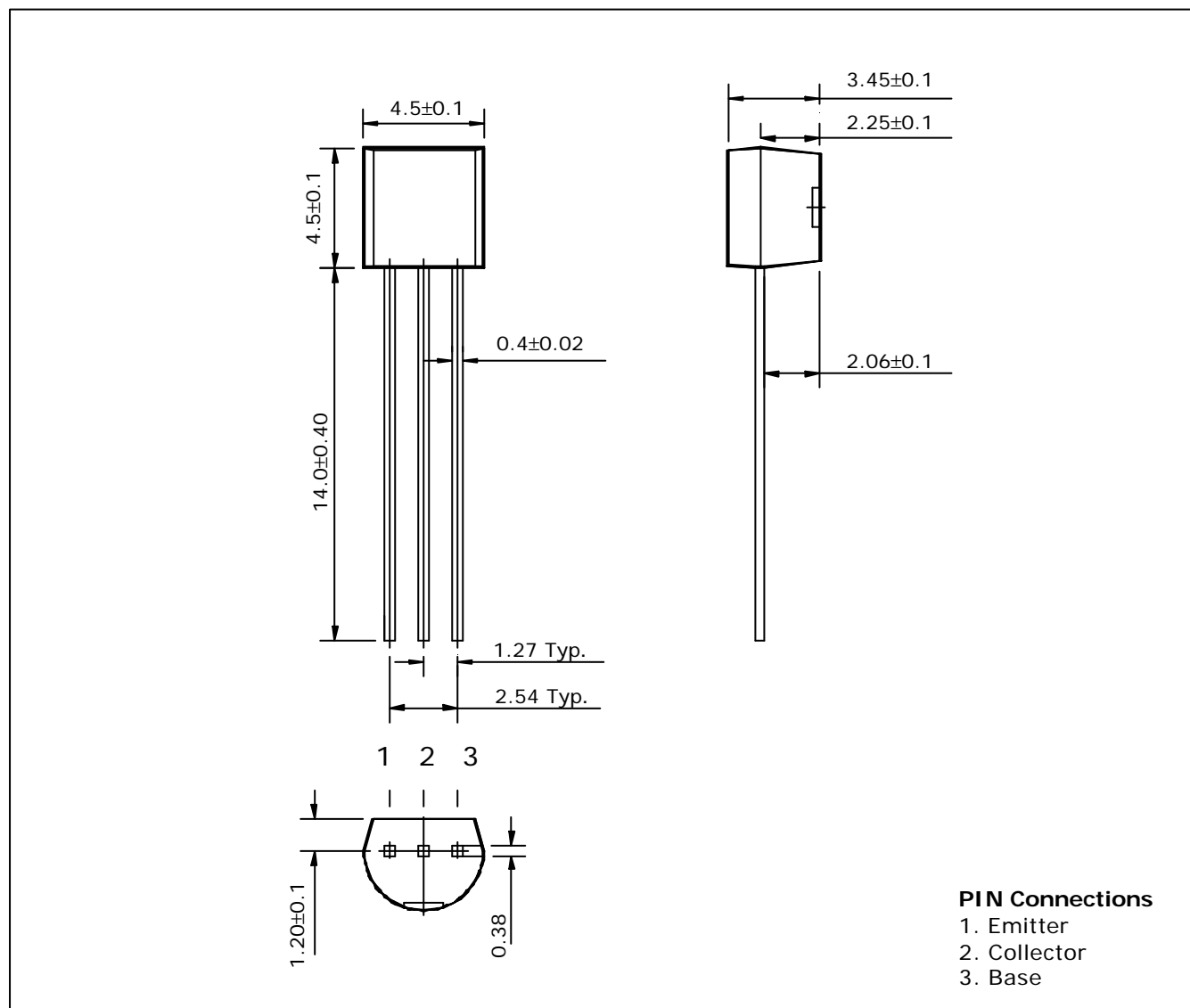

## Absolute maximum ratings

(Ta=25° C)

Characteristic	Symbol	Ratings	Unit
Collector-Base voltage	$V_{CBO}$	40	V
Collector-Emitter voltage	$V_{CEO}$	15	V
Emitter-Base voltage	$V_{EBO}$	7	V
Collector current	$I_C$	5	A
Collector dissipation	$P_C$	625	mW
Junction temperature	$T_j$	150	°C
Storage temperature	$T_{stg}$	-55 ~ 150	°C

## Electrical Characteristics

(Ta=25° C)

Characteristic	Symbol	Test Condition	Min.	Typ.	Max.	Unit
Collector-Base breakdown voltage	$BV_{CBO}$	$I_C=50\mu A, I_E=0$	40	-	-	V
Collector-Emitter breakdown voltage	$BV_{CEO}$	$I_C=1mA, I_B=0$	15	-	-	V
Emitter-Base breakdown voltage	$BV_{EBO}$	$I_E=50\mu A, I_C=0$	7	-	-	V
Collector cut-off current	$I_{CBO}$	$V_{CB}=30V, I_E=0$	-	-	0.1	$\mu A$
Emitter cut-off current	$I_{EBO}$	$V_{EB}=5V, I_C=0$	-	-	0.1	$\mu A$
DC current gain	$h_{FE1}$	$V_{CE}=2V, I_C=0.5A$	160	-	320	-
	$h_{FE2}$	$V_{CE}=2V, I_C=3A$	40	-	-	-
Collector-Emitter saturation voltage	$V_{CE(sat)}$	$I_C=3A, I_B=150mA$	-	-	0.3	V
Transition frequency	$f_T$	$V_{CE}=6V, I_E=-50mA$	-	150	-	MHz
Collector output capacitance	$C_{ob}$	$V_{CB}=20V, I_E=0, f=1MHz$	-	-	50	pF

Electrical Characteristic Curves

Fig. 1  $P_c - T_a$

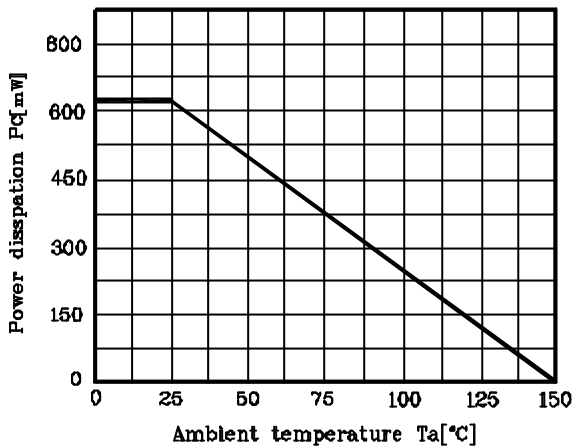

Fig. 2  $h_{FE} - I_c$

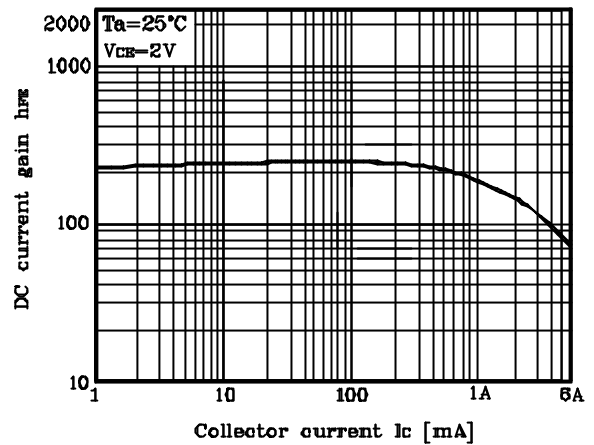

Fig. 3  $V_{CE(sat)} - I_c$

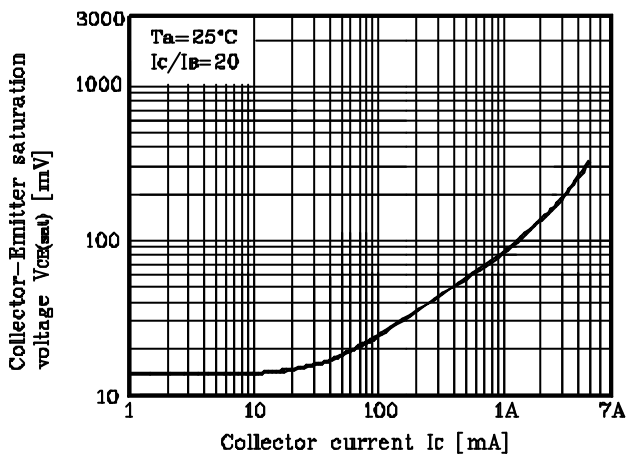

Fig. 4  $f_T - I_c$

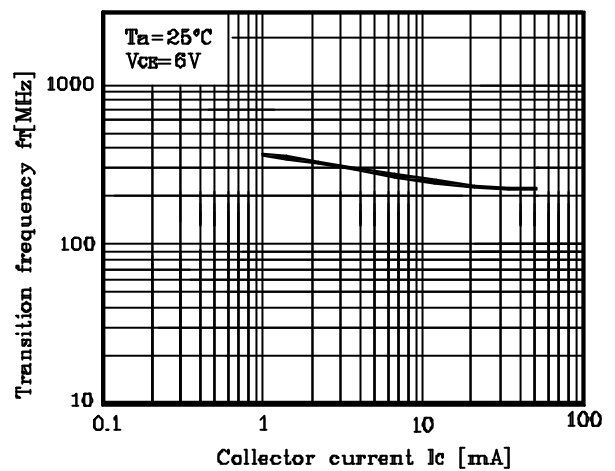

Fig. 5  $C_{ob} - V_{CB}$

