

CT1815

10MHz Low Level Serial Interface for MIL-STD-1397 Type D

Features

- Internally set threshold
- Matched to 50 ohm system impedance power on and off
- Operates with ± 5 volt supplies
- Power management
- Accepts synchronous input data
- Unique Manchester decoder requires no clock
- Generates one clock per received bit
- May be used for serial decoding of indefinite word lengths
- Other Wire and Fiber Optic types available



General Description

The CT1815 is a single hybrid micro-circuit which incorporates a serial encoder, transceiver, and Manchester decoder in one package. The encoder accepts serial NRZ data in conjunction with two synchronous clocks. This data stream is then Manchester encoded and maybe transformer coupled thru an external transformer to a 75 ohm tri-axial cable for transmission through up to 1000 feet of cable. The CT1815 receiver section accepts bipolar Manchester encoded signals and passes level detected signals to the serial decoder. The serial decoder reconstructs an NRZ data stream with derived clock. This allows the data to be processed by our CT2500 monolithic protocol chip for MIL-STD-1397 serial interfaces. All the input and output signals of the CT1815 are completely compatible with the CT2500. The CT1815 has a power management function. A transmitter standby mode is available to reduce the overall power consumption of the CT1815. Aeroflex Circuit Technology is an 80,000ft² MIL-PRF-38534 certified facility in Plainview, N.Y.

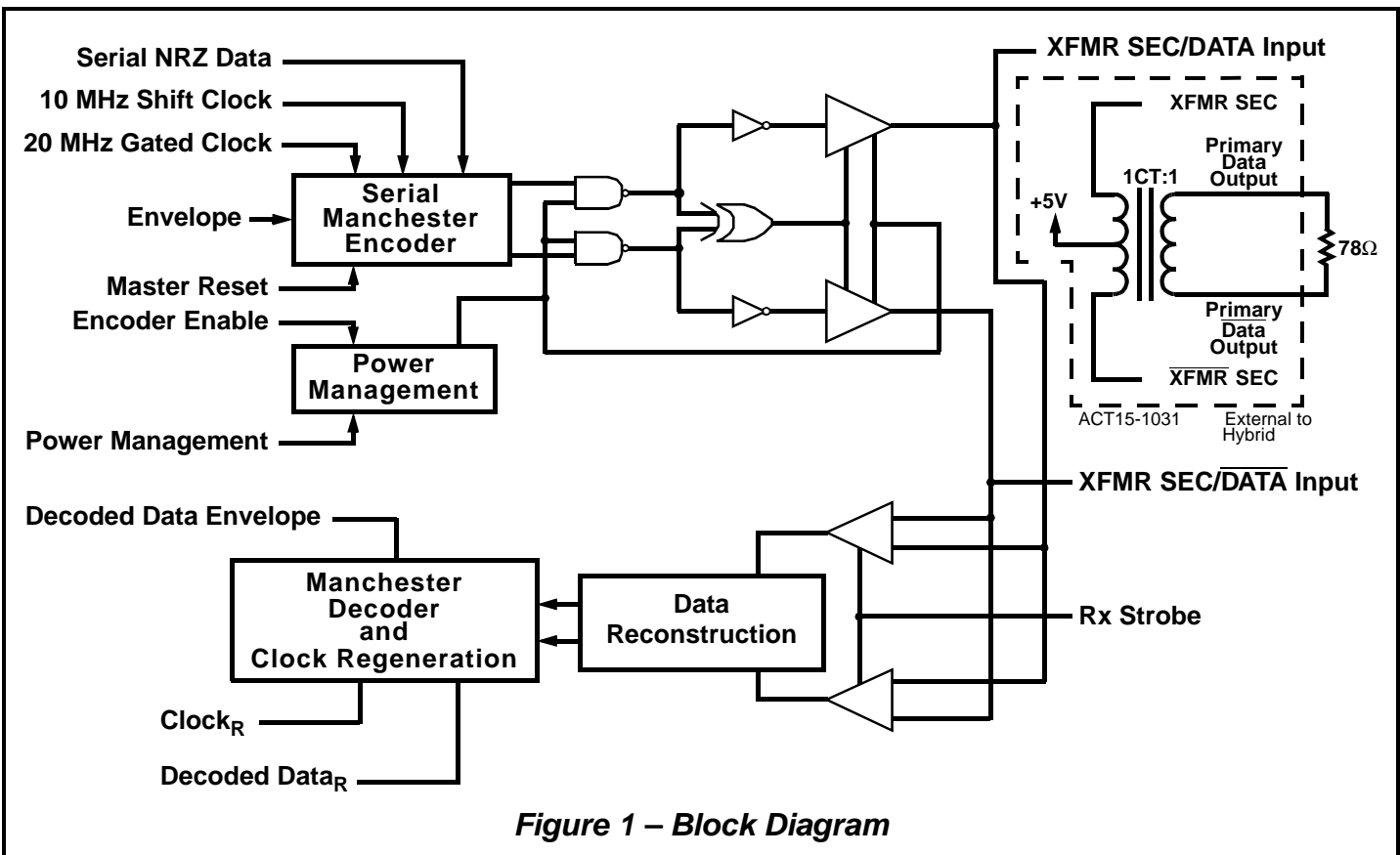

Figure 1 – Block Diagram

Transmission

The CT1815 accepts synchronous NRZ Data in conjunction with two clocks signals. The NRZ data stream is then converted to Manchester code which is transformer coupled to a 75 ohm Tri-axial cable for transmission up to 1000 ft.

The transmitter may be placed into standby condition. This reduces power consumption by approximately 600mW. Power management is made available via two standard TTL input pins. The Receiver is always active and is not affected by the power management circuitry.

The transceiver is matched for 75 ohm operation over a wide band of frequencies. This condition is maintained with power on and off.

Reception

The CT1815 receiver section accepts a bipolar signal which is level detected and passed to the serial decoder. The decoder section reconstructs the data and strips the clock from the serial stream. An NRZ decoded data stream is then produced

synchronously with a recovered clock. The receiver is designed to meet the MIL-STD-1397 Type D requirements.

Electrical Requirements

The specification detailed herein encompasses a hybrid Transceiver/Encoder-Decoder designed to meet the requirements of the MIL-STD-1397 Type D.

The transceiver is transformer coupled to the specified triaxial cable and is screened to the individual test methods of MIL-STD-883

See Figure 1 for Block Diagram. Inputs and Outputs are all Synchronous NRZ DATA STREAMS

Transformer Isolation

The CT1815 is connected with pin 3 and pin 32 to the ACT15-1031 transformer secondary winding. The center tap of the secondary winding is connected to +5 volts. For matching 75Ω load operation, a 78Ω resistor must be placed across the primary winding of the transformer.

Encoder Timing / Transmitter Specification

Symbol	Parameter / Condition	Min	Typ	Max	Unit
Encode Timing					
t1	Input data set-up time	10		40	ns
t2	Encode clock set-up time	10		40	ns
t3	Encode envelope set-up time	10		40	ns
t4	Encode envelope turn-off time	10		35	ns
t5	Transmitter activation set-up time	150			ns
t6	Transmitter deactivation hold-time	50			ns
tw1	20 MHz gated CK pulse width high	20		30	ns
tw2	Encoder shift CK pulse width high	45		55	ns
Output Signals					
Va	Output amplitude (see Figure 2)	2.75	3.25	3.75	V
T	Pulse period	97	100	103	ns
Ts	Width of 1st positive half bit	45		65	ns
Te	Width of last half bit	47		65	ns
T/2	Half pulse period	47	50	53	ns
Tr	Pulse rise time			2.0	V/ns
Tf	Pulse fall time			2.0	V/ns
Vs	Voltage overshoot			350	mV
Tos	Offset Voltage 2T after last zero crossing			150	mV
Tdtx	Delay from 20 MHz clock input to data output on transformer secondary		20	55	ns
Zo	Output Impedance	70	75	80	Ω

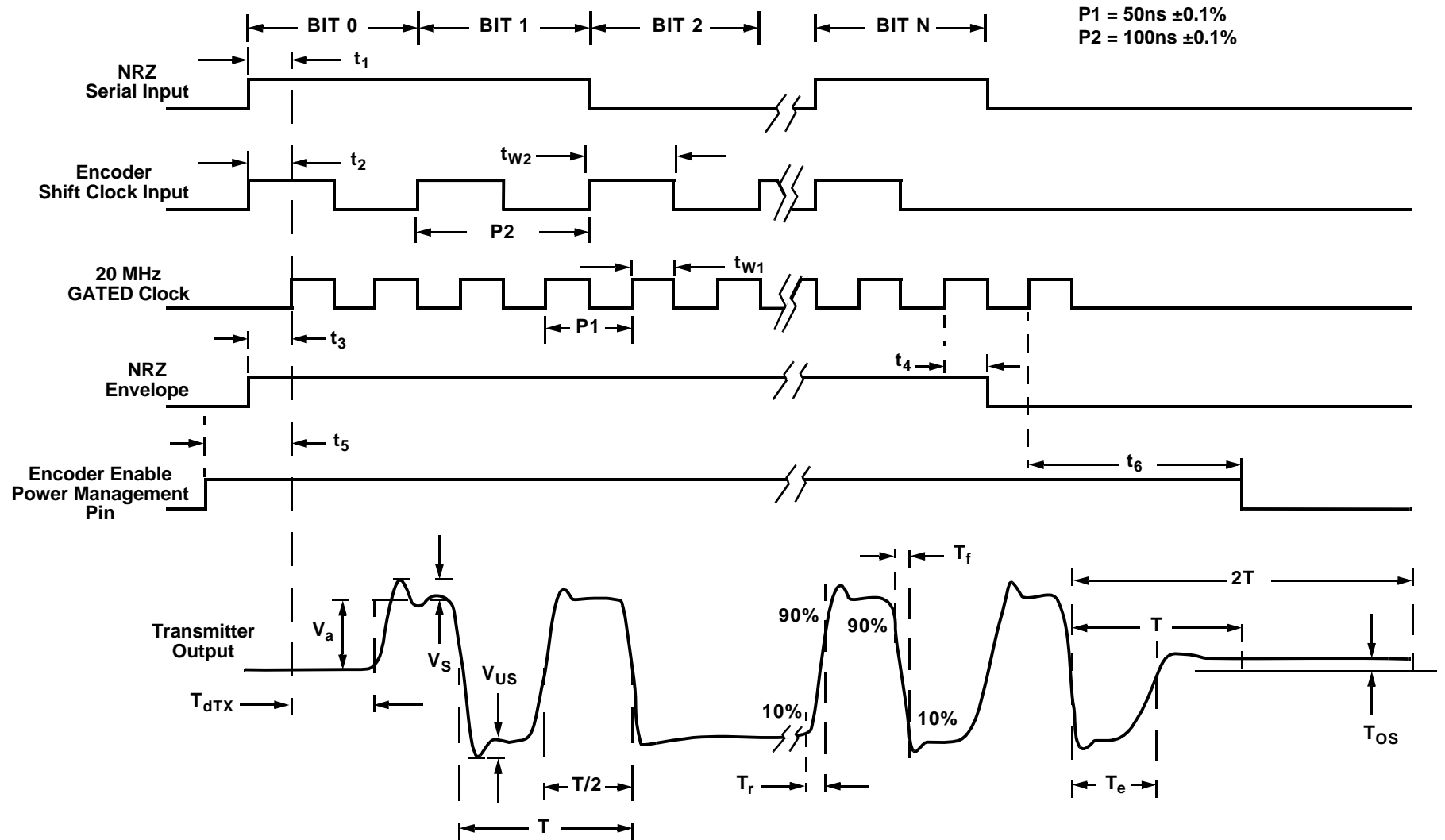

Figure 2 Encoder – Transmitter Timing

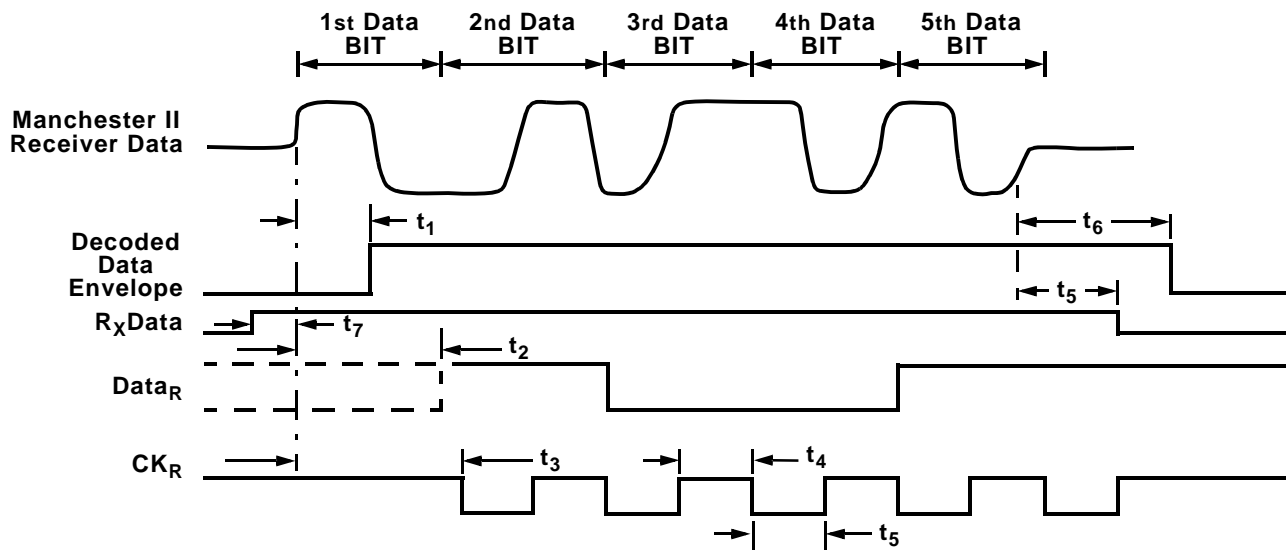

Figure 3 Receiver / Decode Timing

Symbol	Parameter / Condition	Min	Nom	Max	Units
t1	Envelope delay time	-	45	100	nsec
t2	Data decode delay	-	115	125	nsec
t3	Clock low transition delay	-	130	-	nsec
t4	Clock _R high time	35	50	65	nsec
t5	Clock _R low time	35	50	65	nsec
t6	Envelope off delay	120	-	270	nsec
t7	Receiver strobe enable to input data set-up time	5	-	-	nsec
t8	Receiver strobe disable to input data hold-time	20	-	-	?

Power Management Functional Table

Encoder Enable (Pin 10)	Power Management Input (Pin 9)	Receiver Status	Transmitter Status
0	0	Active	Standby
X	1	Active	Active
1	X	Active	Active

Power management timing see Figure 2.

Functional Description and Pinout

Pin #	Pin Name	Function	Load or Drive
1	No connection		
2	No connection		
3	XFMR secondary/ RX data input	Transmitter-receiver I/O pin	
4	Test Point	No connection permitted	
5	Test Point	No connection permitted	
6	Test Point	No connection permitted	
7	-5 Volts		
8	R _X strobe	Low level disables receiver	3 S loads
9	Power management input	Controls transmitter power consumption in conjunction with pin 10	1 S load
10	Encoder enable	Controls transmitter power consumption in conjunction with pin 9	1 S load
11	Case/signal GND		
12	Case/signal GND		
13	Decoded data envelope	High after reception of first half bit; goes low after reception of last half bit (normally low in inactive state)	4 S drive
14	TP3 test point	Alignment point: no electrical connection permitted	
15	TP1 test point	Alignment point: no electrical connection permitted	
16	TP2 test point	Alignment point: no electrical connection permitted	
17	-5 Volts		
18	TP4 test point	Alignment point: no electrical connection permitted	
19	Clock _R	Reconstructed clock; one clock pulse per input bit received	3 S drive
20	No connection		
21	Decoded Data _R	NRZ reconstructed data. Sampled on clock _R rising edge	3 S drive
22	No connection		
23	+5 volts		
24	+5 volts		
25	10 MHz encoder shift clock	One cycle required per data bit. Must be high in first half of bit cell	1 S load
26	NRZ serial input data	Serial input to be Manchester encoded with the 20 MHz gated CK	1 S load
27	Encode envelope	Must be high to enable transmission; must go low before reception of last 20 MHz positive edge to complete transmission	1 S load
28	20 MHz gated clock (encoder)	Each bit to be encoded requires two positive edges of the 20 MHz CK. These edges must occur at 25ns and 75ns into the bit cell. The end of transmission requires an additional edge in conjunction with a logic low on the encode envelope. t _R , t _F ≤ 5nsec.	1 S load
29	Master reset reset pulse ≤15 nsec	Logic low resets encoder	2 S load
30	No connection		
31	No connection		
32	XFMR secondary/ RX DATA input	Transmitter-Receiver I/O pin	
33	XFMR secondary	Secondary isolated winding, same phase as outer conductor	
34	XFMR primary/ TX DATA output	Transformer lead for connection to outer conductor of tri-axial	

Load and Drive Definitions

1 S load: requires
 $I_{IL} = -2\text{mA max.}, V_{IL} = 0.8\text{V max}$
 $I_{IH} = 50\mu\text{A max.}, V_{IH} = 2.5\text{V min } C_{IN} < 15 \text{ pf}$

1 S drive:
 $I_{OH} = 50\mu\text{A min.}, V_{OH} = 2.5\text{V min}$
 $I_{OL} = -2 \text{ mA min.}, V_{OL} = 0.5\text{V max}$

Power Consumption

	Current (mA)	
	Typ	Max
I_{CC} Standby mode	235	305
I_{EE} Standby mode	75	100
I_{CC} 100% Transmission	447	585
I_{EE} 100% Transmission	242	315

Absolute Maximum Ratings

V_{CC} (Pins 23, 24) +7 Volts Max
 V_{EE} (Pins 7, 17) -7 Volts Max
Logic Input Voltage Applied:
Logic Low -1.2V @ 10mA Max
Logic High +5.5 Volts

Damage will not result from cable open circuits or short circuits (on the transformer primary) of the following types:

- Line-to-line
- Line-to-ground
- 120V AC 60Hz common mode signal

Environmental Parameters

Operating Temperature -55°C to +100°C Case
Storage Temperature -55°C to +150°C
Screened per individual test methods of MIL-STD-883.

Ordering Information

Model Number	Package
CT1815	Plug-in Package
CT1815FP	Flat Package

Plug-In Package Outline

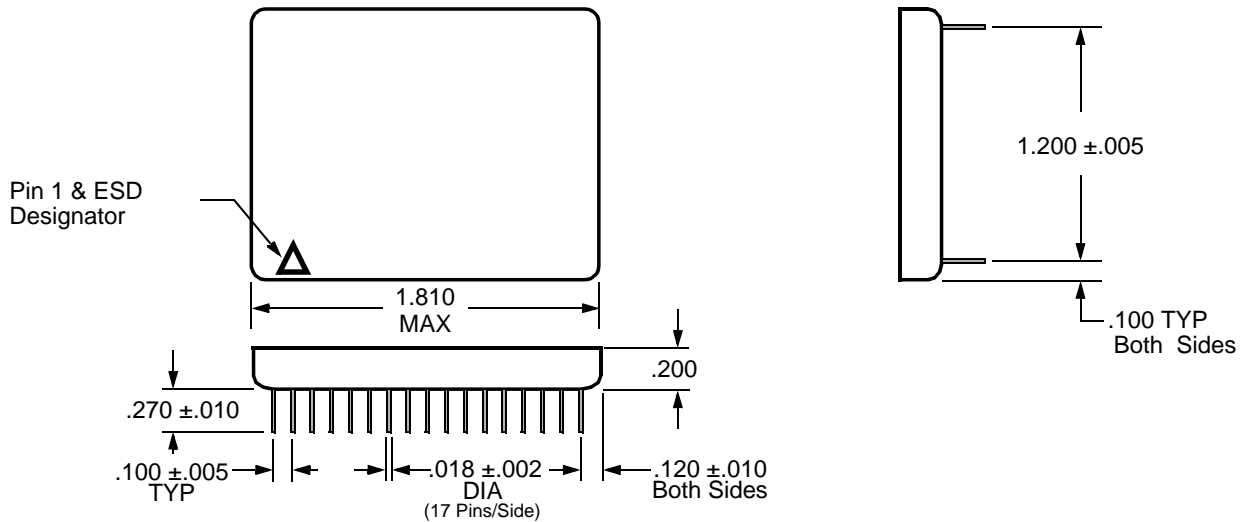

Flat Package Outline

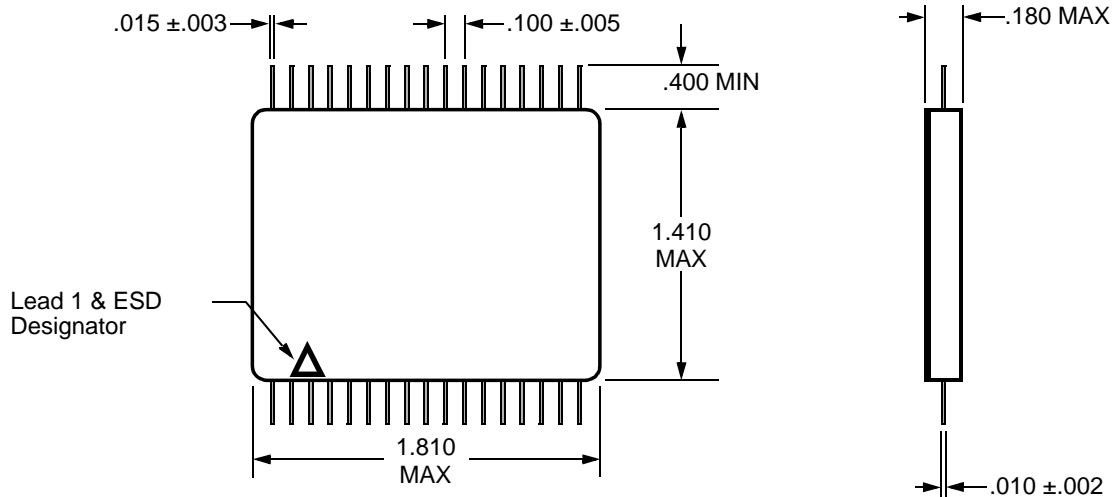

Aeroflex Circuit Technology
35 South Service Road
Plainview New York 11830

Telephone: (516) 694-6700
FAX: (516) 694-6715
Toll Free Inquiries: 1-(800)THE-1553