

**Features**

- Gen. 4 Ultrafast Speed IGBT Technology
- HEXFRED™ Diode with UltraSoft Reverse Recovery
- Very Low Conduction and Switching Losses
- Optional SMT Thermistor (NTC)
- Aluminum Nitride DBC
- Very Low Stray Inductance Design for High Speed Operation
- UL approved ( file E78996 )

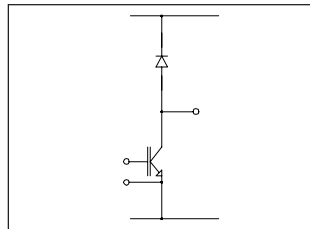

$V_{CES} = 600V$   
 $I_C = 100A,$   
 $T_C = 25^{\circ}C$

**Benefits**

- Optimized for Welding, UPS and SMPS Applications
- Operating Frequencies > 20 kHz Hard Switching, >200 kHz Resonant Mode
- Low EMI, requires Less Snubbing
- Direct Mounting to Heatsink
- PCB Solderable Terminals
- Very Low Junction-to-Case Thermal Resistance

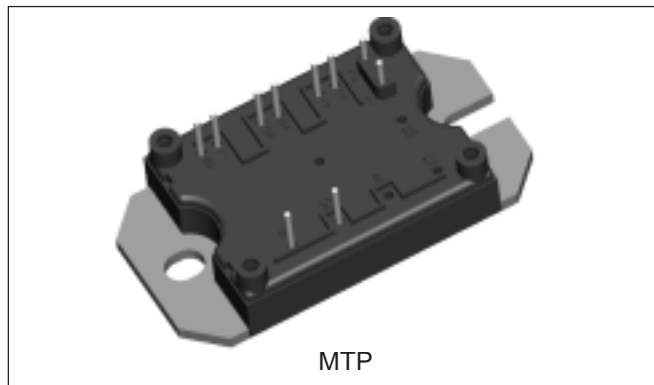

**Absolute Maximum Ratings**

Parameters		Max	Units
$V_{CES}$	Collector-to-Emitter Voltage	600	V
$I_C$	Continuous Collector Current	@ $T_C = 25^{\circ}C$	100
		@ $T_C = 122^{\circ}C$	50
$I_{CM}$	Pulsed Collector Current	200	
$I_{LM}$	Peak Switching Current	200	
$I_F$	Diode Continuous Forward Current	@ $T_C = 100^{\circ}C$	48
$I_{FM}$	Peak Diode Forward Current	200	
$V_{GE}$	Gate-to-Emitter Voltage	$\pm 20$	V
$V_{ISOL}$	RMS Isolation Voltage, Any Terminal to Case, $t = 1$ min	2500	
$P_D$	Maximum Power	IGBT @ $T_C = 25^{\circ}C$	445
		@ $T_C = 100^{\circ}C$	175
	Dissipation	Diode @ $T_C = 25^{\circ}C$	205
		@ $T_C = 100^{\circ}C$	83

**Electrical Characteristics @ T<sub>J</sub> = 25°C (unless otherwise specified)**

Parameters		Min	Typ	Max	Units	Test Conditions
V <sub>(BR)CES</sub>	Collector-to-Emitter Breakdown Voltage	600			V	V <sub>GE</sub> = 0V, I <sub>C</sub> = 250μA
V <sub>CE(on)</sub>	Collector-to-Emitter Voltage		1.69	2.31		V <sub>GE</sub> = 15V, I <sub>C</sub> = 50A
			1.96	2.55		V <sub>GE</sub> = 15V, I <sub>C</sub> = 100A
			1.88	2.24		V <sub>GE</sub> = 15V, I <sub>C</sub> = 100A, T <sub>J</sub> = 150°C
V <sub>GE(th)</sub>	Gate Threshold Voltage	3		6		I <sub>C</sub> = 0.5mA
B <sub>VR</sub>	Diode Reverse Breakdown Voltage	600				I <sub>R</sub> = 200μA
ΔV <sub>GE(th)</sub> /ΔT <sub>J</sub>	Temperature Coeff. of Threshold Voltage		- 13		mV/°C	V <sub>CE</sub> = V <sub>GE</sub> , I <sub>C</sub> = 500μA
g <sub>fe</sub>	Forward Transconductance	22	29		S	V <sub>CE</sub> = 50V, I <sub>C</sub> = 100A
I <sub>CES</sub>	Collector-to-Emitter Leaking Current			0.25	mA	V <sub>GE</sub> = 0V, V <sub>CE</sub> = 600V
				6		V <sub>GE</sub> = 0V, V <sub>CE</sub> = 600V, T <sub>J</sub> = 150°C
V <sub>FM</sub>	Diode Forward Voltage Drop		1.64	1.82	V	I <sub>F</sub> = 100A, V <sub>GE</sub> = 0V
			1.56	1.74		I <sub>F</sub> = 100A, V <sub>GE</sub> = 0V, T <sub>J</sub> = 150°C
I <sub>GES</sub>	Gate-to-Emitter Leakage Current			± 250	nA	V <sub>GE</sub> = ± 20V

**Switching Characteristics @ T<sub>J</sub> = 25°C (unless otherwise specified)**

Parameters		Min	Typ	Max	Units	Test Conditions
Q <sub>g</sub>	Total Gate Charge (turn-on)		370	555	nC	I <sub>C</sub> = 100A V <sub>CC</sub> = 480V V <sub>GE</sub> = 15V
Q <sub>ge</sub>	Gate-Emitter Charge (turn-on)		64	96		
Q <sub>gc</sub>	Gate-Collector Charge (turn-on)		163	245		
E <sub>on</sub>	Turn-On Switching Loss		0.7	1.2	mJ	I <sub>C</sub> = 50A, V <sub>CC</sub> = 480V, V <sub>GE</sub> = 15V, R <sub>g</sub> = 5Ω
E <sub>off</sub>	Turn-Off Switching Loss		1.7	2.6		
E <sub>ts</sub>	Total Switching Loss		2.4	3.8		
E <sub>on</sub>	Turn-On Switching Loss		1.1	1.7	mJ	I <sub>C</sub> = 50A, V <sub>CC</sub> = 480V, V <sub>GE</sub> = 15V R <sub>g</sub> = 5Ω, T <sub>J</sub> = 125°C
E <sub>off</sub>	Turn-Off Switching Loss		2.5	3.8		
E <sub>ts</sub>	Total Switching Loss		3.6	5.5		
C <sub>ies</sub>	Input Capacitance		9800	14700	pF	V <sub>GE</sub> = 0V V <sub>CC</sub> = 30V f = 1.0 MHz
C <sub>oes</sub>	Output Capacitance		602	903		
C <sub>res</sub>	Reverse Transfer Capacitance		121	182		
C <sub>t</sub>	Diode Junction Capacitance		118	177		
t <sub>rr</sub>	Diode Reverse Recovery Time		99	150	ns	V <sub>CC</sub> = 480V, I <sub>C</sub> = 50A
I <sub>rr</sub>	Diode Peak Reverse Current		6.5	9.8	A	di/dt = 200A/μs
Q <sub>rr</sub>	Diode Recovery Charge		320	735	nC	R <sub>g</sub> = 5Ω
di <sub>(rec)</sub> /dt	Diode Peak Rate of Fall of Recovery During t <sub>b</sub>		236		A/μs	

### Thermistor Specifications (50MT060ULST only)

Parameters	Min	Typ	Max	Units	Test Conditions
R <sub>0</sub> <sup>(1)</sup> Resistance		30		kΩ	T <sub>0</sub> = 25°C
β <sup>(1)(2)</sup> Sensitivity index of the thermistor material		4000		K	T <sub>0</sub> = 25°C T <sub>1</sub> = 85°C

(1) T<sub>0</sub>, T<sub>1</sub> are thermistor's temperatures

$$(2) \frac{R_0}{R_1} = \exp \left[ \beta \left( \frac{1}{T_0} - \frac{1}{T_1} \right) \right], \text{ Temperatures in kelvin}$$

### Thermal- Mechanical Specifications

Parameters	Min	Typ	Max	Units
T <sub>J</sub> Operating Junction Temperature Range	- 40		150	°C
T <sub>STG</sub> Storage Temperature Range	- 40		125	
R <sub>thJC</sub> Junction-to-Case	IGBT	0.18	0.28	°C/ W
	Diode	0.4	0.6	
R <sub>thCS</sub> Case-to-Sink (Heatsink Compound Thermal Conductivity = 1 W/mK)	Module	0.06		
T Mounting torque to heatsink (3)		3 ± 10%		Nm
Wt Weight		66		g

(3) A mounting compound is recommended and the torque should be checked after 3 hours to allow for the spread of the compound. Lubricated threads

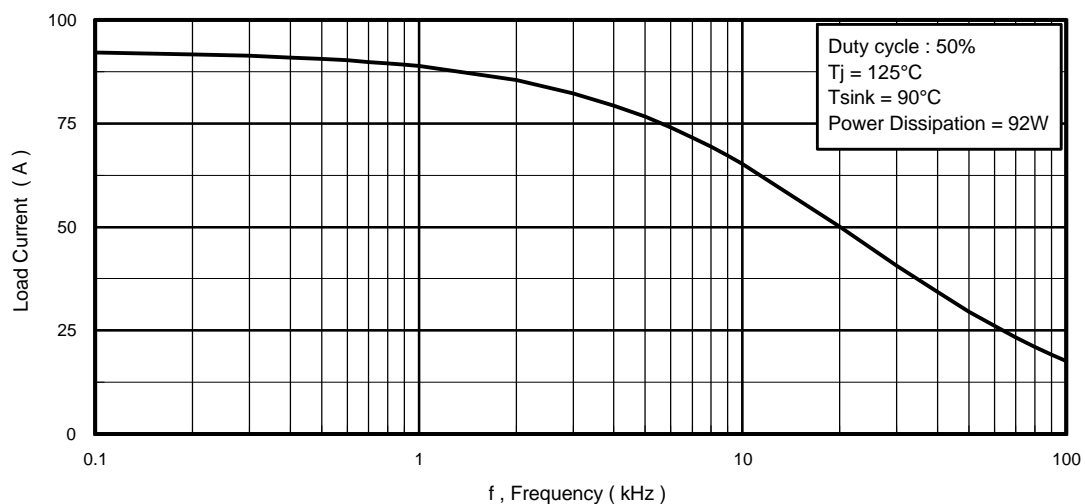
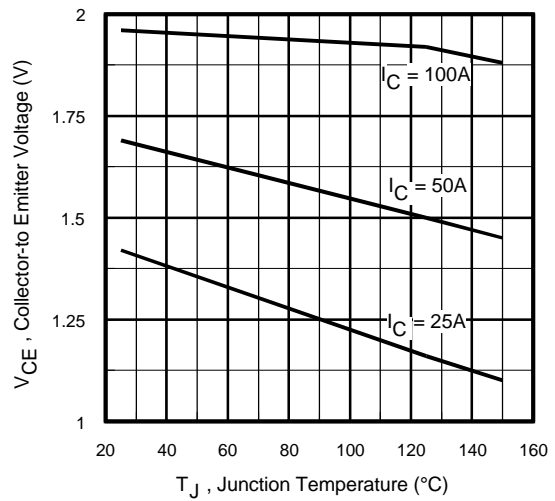
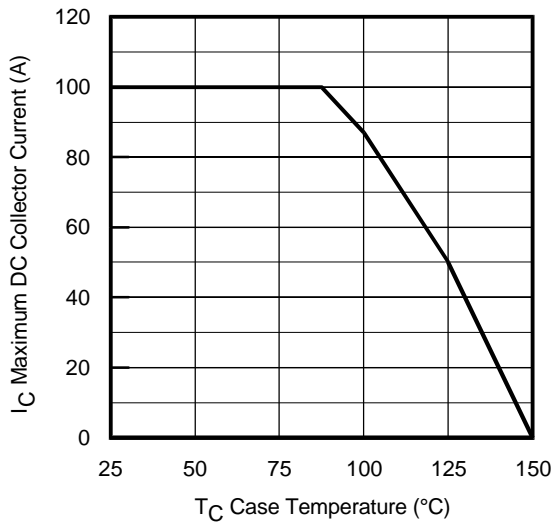
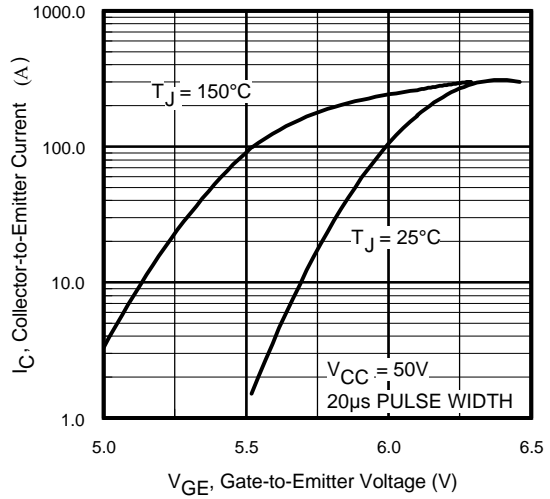
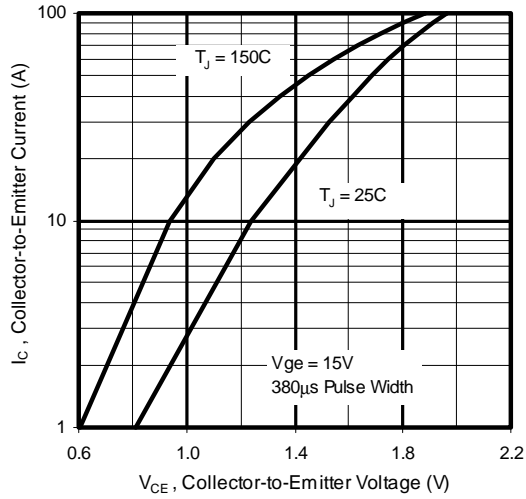

Fig. 1 - Typical Load Current vs. Frequency  
(Load Current = I<sub>RMS</sub> of fundamental)



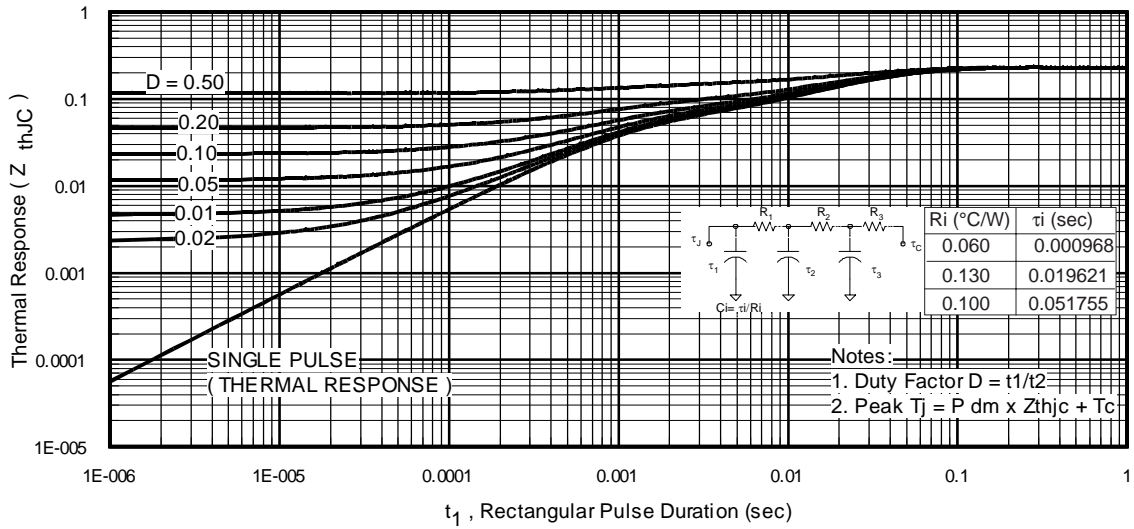

Fig. 6a Maximum Transient Thermal Impedance, Junction-to-Case (IGBT)

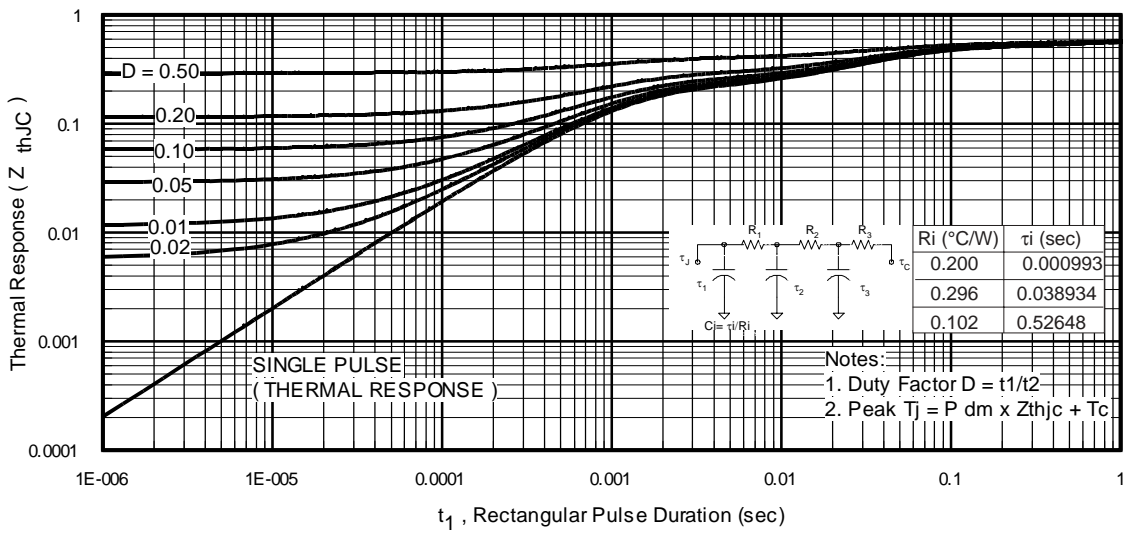

Fig. 6b Maximum Transient Thermal Impedance, Junction-to-Case (DIODE)

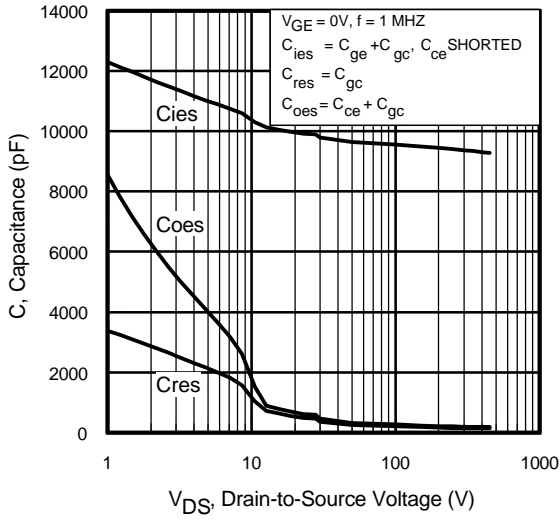

Fig. 7 - Typical Capacitance vs. Collector-to-Emitter Voltage

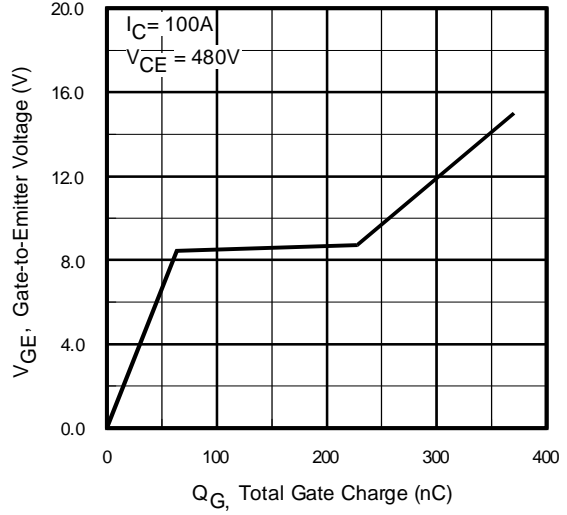

Fig. 8 - Typical Gate Charge vs. Gate-to-Emitter Voltage

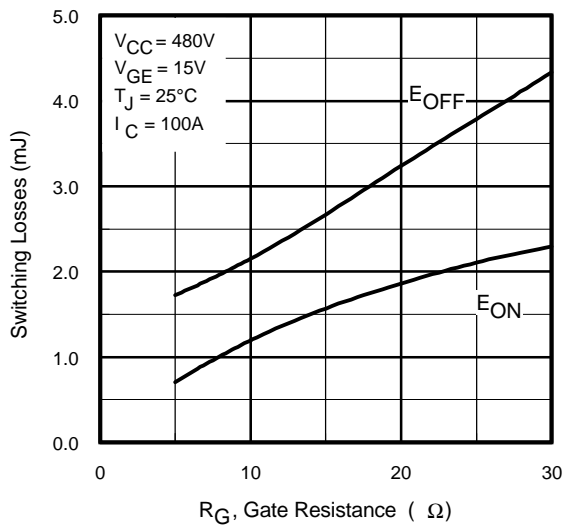

Fig. 9 - Typical Switching Losses vs. Gate Resistance

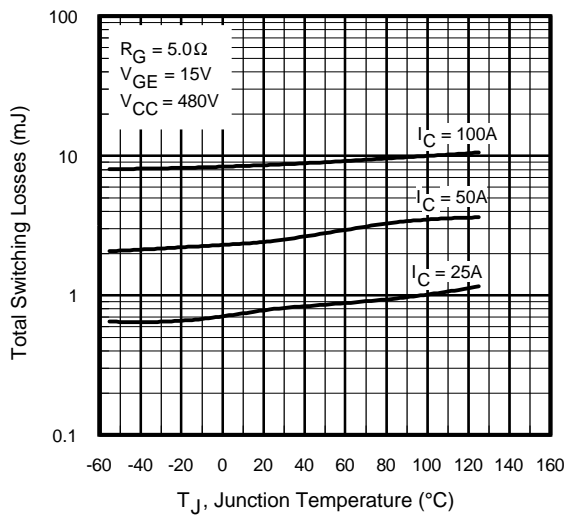
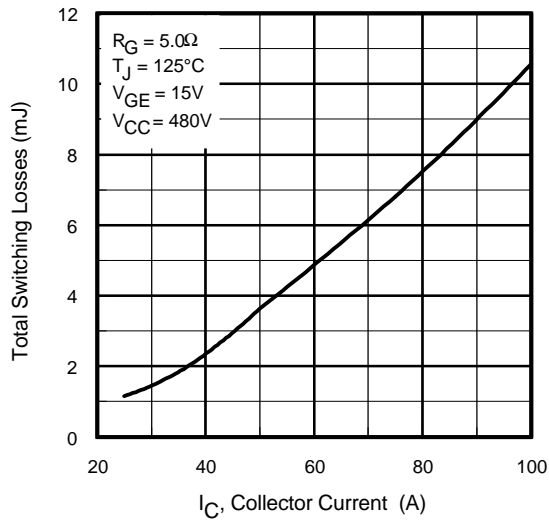
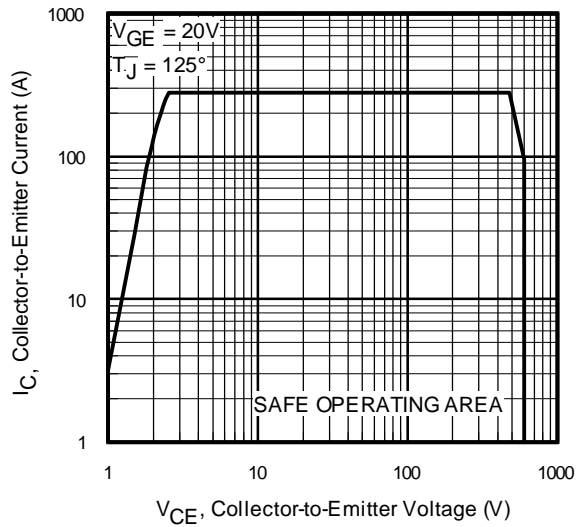

Fig. 10 - Typical Switching Losses vs. Junction Temperature



**Fig. 11** - Typical Switching Losses vs. Collector-to-Emitter Current



**Fig. 12** - Turn-Off SOA

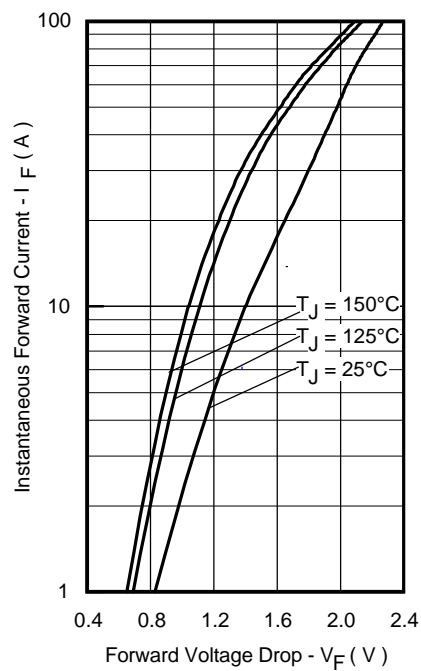

**Fig. 13** - Maximum Forward Voltage Drop vs. Instantaneous Forward Current

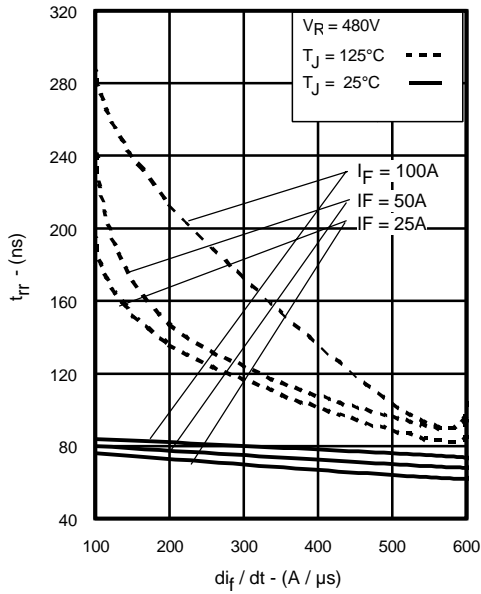

Fig. 14 - Typical Reverse Recovery vs.  $di_f/dt$

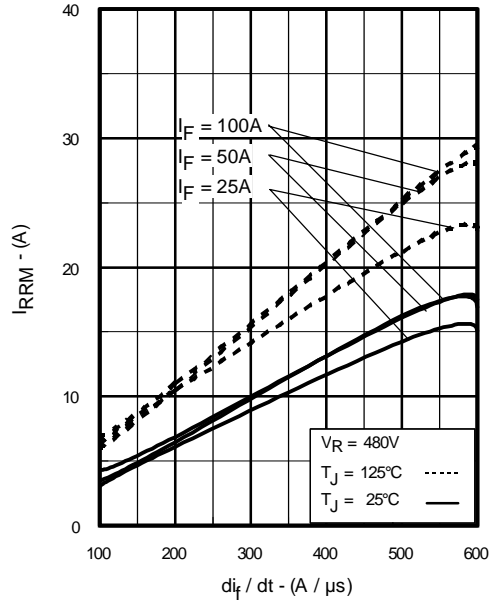

Fig. 15 - Typical Recovery Current vs.  $di_f/dt$

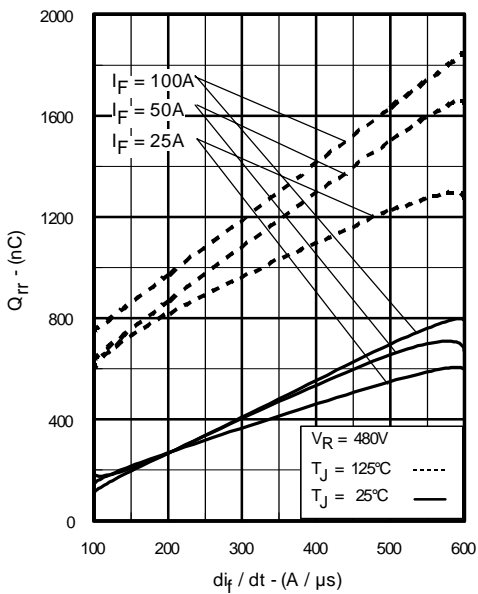

Fig. 16 - Typical Stored Charge vs.  $di_f/dt$

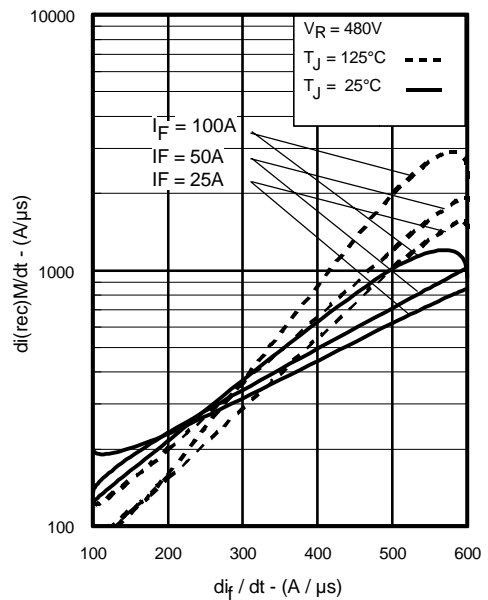
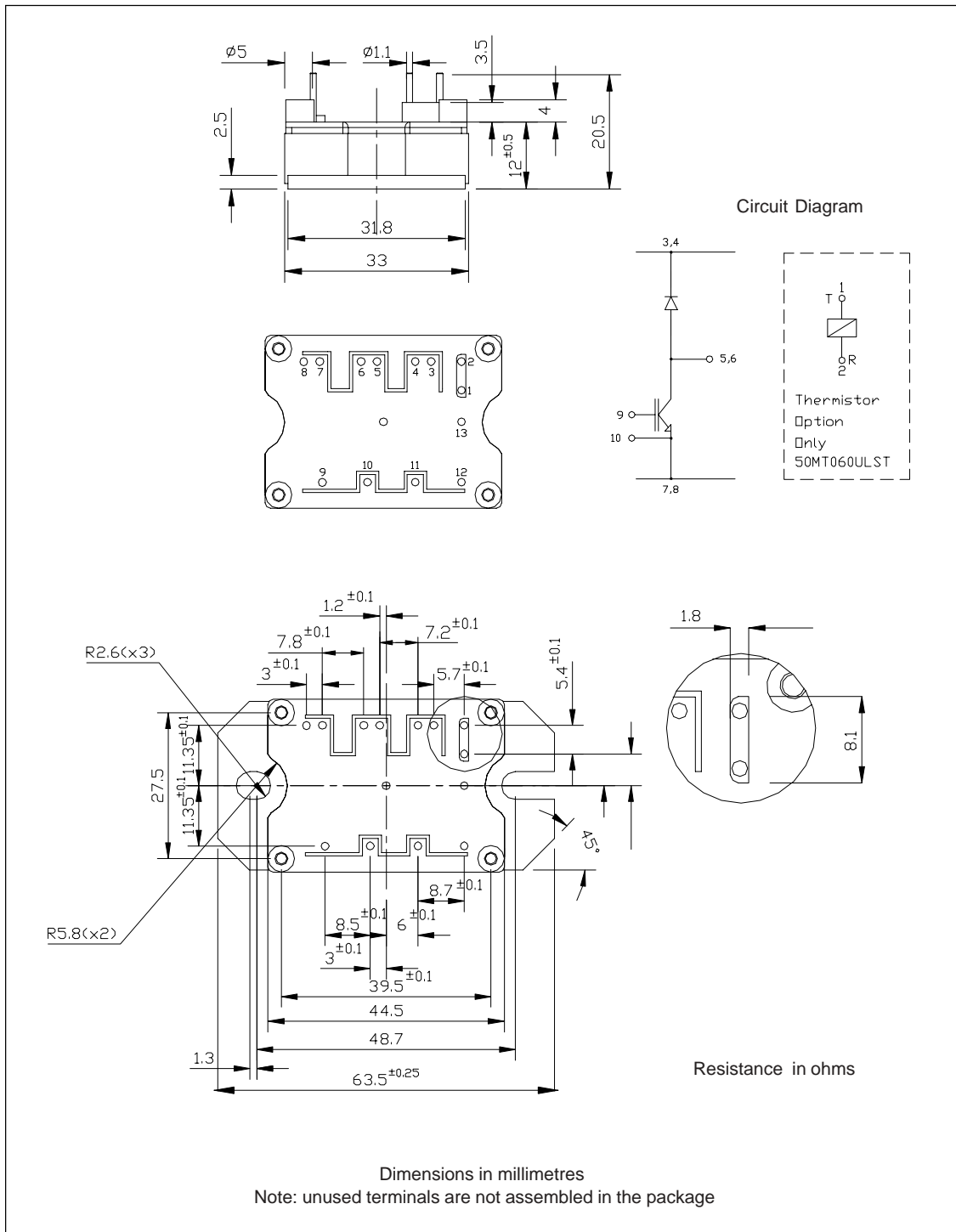

Fig. 17 - Typical  $di_{(rec)M}/dt$  vs.  $di_f/dt$



**Outline Table**



### Ordering Information Table

Device Code

50	MT	060	U	LS	-
①	②	③	④	⑤	⑥

- 1** - Current rating (50 = 50A)
- 2** - Essential Part Number
- 3** - Voltage code (060 = 600V)
- 4** - Speed/ Type (U = Ultra Fast IGBT)
- 5** - Circuit Configuration (LS = Low Side Chopper)
- 6** - Special Option
  - Empty = no special option
  - T = Thermistor

Data and specifications subject to change without notice.  
This product has been designed and qualified for Industrial Level.  
Qualification Standards can be found on IR's Web site.