

# TPD2004F

## 2-ch SQUIB DRIVER FOR AIR BAGS

Manufactured by the Bi-CMOS-DMOS process, this 2-channel squib drive IPD is designed for use in SRS electronic system air bags.

### FEATURES

- Using independent four-channel inputs, this IC controls two high-side and two low-side switches, making it possible to drive two squibs directly.
- Incorporates various diagnostic functions (analog multiplexer outputs) :
  - Squib short-to-battery diagnosis
  - Squib short-to-ground diagnosis
  - Squib open-circuit diagnosis
  - Safing sensor-ON unusual diagnosis
  - High-redundancy, upstream arrangement for safing sensor
  - Squib short diagnosis
  - Squib drive MOSFET diagnosis
- Chip select function allows for multi-channel structure to be materialized using minimum control lines.
- Comes in a 24-pin SSOP surface mount package.
- Supports emboss taping.

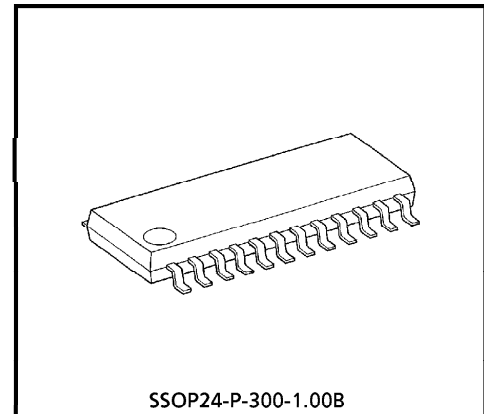

Weight : 0.29g (Typ.)

980508EBA1

- TOSHIBA is continually working to improve the quality and the reliability of its products. Nevertheless, semiconductor devices in general can malfunction or fail due to their inherent electrical sensitivity and vulnerability to physical stress. It is the responsibility of the buyer, when utilizing TOSHIBA products, to observe standards of safety, and to avoid situations in which a malfunction or failure of a TOSHIBA product could cause loss of human life, bodily injury or damage to property. In developing your designs, please ensure that TOSHIBA products are used within specified operating ranges as set forth in the most recent products specifications. Also, please keep in mind the precautions and conditions set forth in the TOSHIBA Semiconductor Reliability Handbook.
- The products described in this document are subject to foreign exchange and foreign trade laws.
- The information contained herein is presented only as a guide for the applications of our products. No responsibility is assumed by TOSHIBA CORPORATION for any infringements of intellectual property or other rights of the third parties which may result from its use. No license is granted by implication or otherwise under any intellectual property or other rights of TOSHIBA CORPORATION or others.
- The information contained herein is subject to change without notice.

PIN ASSIGNMENT

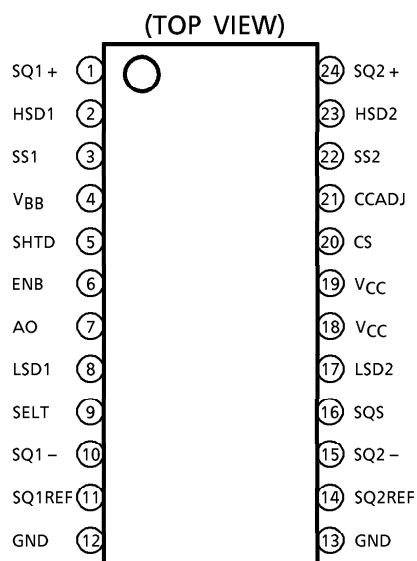

(Note) That because of its MOS structure, this product is sensitive to static electricity.



## PIN DESCRIPTION

PIN No.	SYMBOL	PIN DESCRIPTION
1	SQ1 +	Squib positive (+) side output pin for channel 1
2	HSD1	High-side driver control input pin for Channel 1 (Pull-down)
3	SS1	Safing sensor connect pin for channel 1
4	V <sub>BB</sub>	Backup block power supply input pin
5	SHTD	Control input pin for short diagnosis (Pull-down)
6	ENB	INHIBIT input pin to inhibit ignition when this input is pulled low. (Pull-down)
7	AO	Analog multiplexer output pin
8	LSD1	Low-side driver control input pin for Channel 1 (Pull-up)
9	SELT	Control input pin for switching between diagnosis line and analog multiplexer (Pull-down)
10	SQ1 -	Squid negative (-) side output pin for channel 1 (Shared with reference resistor pin for short diagnosis)
11	SQ1REF	Shorting diagnosis reference resistor pin for channel 1
12, 13	GND	Ground pin (Two pins)
14	SQ2REF	Shorting diagnosis reference resistor pin for Channel 2
15	SQ2 -	Squib negative (-) side output pin for channel 2 (Shared with reference resistor pin shorting diagnosis)
16	SQS	Squib switchover control input pin during each squib diagnosis. (Pull-down)
17	LSD2	Low-side driver control input pin for Channel 2 (Pull-up)
18, 19	V <sub>CC</sub>	5V block power supply input pin (Two pins)
20	CS	Chip select control input pin (Pull-up)
21	CCADJ	Current setup resistor connect pin for short diagnosis constant-current source. (Reference resistor connect pin)
22	SS2	Safing sensor connect pin for Channel 2
23	HSD2	High-side driver control input pin for Channel 2 (Pull-down)
24	SQ2 +	squib positive (+) side output pin for Channel 2

**TRUTH TABLE**

MODE	SQUIB	HSD1	HSD2	LSD1	LSD2	SELT	SHTD	SQS	ENB	CS	MULTIPL EXER ch	DIVIDING VOLTAGE SW
Ignition	SQ1	H	*	L	*	*	*	*	H	*	—	—
	SQ2	*	H	*	L	*	*	*	H	*	—	—
Short Diagnosis	SQ1	L	L	H	H	L	H	L	H	L	1	—
	SQ1	L	L	H	H	H	H	L	H	L	2	—
	SQ2	L	L	H	H	L	H	H	H	L	3	—
	SQ2	L	L	H	H	H	H	H	H	L	4	—
SS1 Potential Diagnosis (Not Divided)	SQ1	L	L	H	H	H	L	L	L	L	5	—
SS2 Potential Diagnosis (Not Divided)	SQ2	L	L	H	H	H	L	H	L	L	7	—
SS1 Potential Diagnosis (Divided)	SQ1	L	L	H	H	H	L	L	H	L	5	SW1
SS2 Potential Diagnosis (Divided)	SQ2	L	L	H	H	H	L	H	H	L	7	SW3
SQ-1 Potential Diagnosis (Not Divided)	SQ1	L	L	H	H	L	L	L	H	L	6	—
SQ-2 Potential Diagnosis (Not Divided)	SQ2	L	L	H	H	L	L	H	H	L	8	—
SQ-1 Potential Diagnosis (Divided)	SQ1	L	L	H	H	L	L	L	L	L	6	SW2
SQ-2 Potential Diagnosis (Divided)	SQ2	L	L	H	H	L	L	H	L	L	8	SW4
High-side Driver Diagnosis	SQ1	H	L	H	H	L	L	L	H	L	6	SW2
	SQ2	L	H	H	H	L	L	H	H	L	8	SW4
Low-side Driver Diagnosis	SQ1	L	L	L	H	L	L	L	H	L	6	—
	SQ2	L	L	H	L	L	L	H	H	L	8	—

\* : Don't Care

(Note) When ENB input is pulled low, ignition is inhibited.

(Note) When CS is high, the diagnostic inputs SELT, SHTD, and SQS are ignored (in logic) and the AO pin is placed in the high-impedance state.

(Note) If ignited under shorted condition, the device may break down.

**FUNCTIONAL DESCRIPTION****(1) 2-ch squib drive function**

Using independent four-channel inputs, this IC controls two high-side and two low-side switches, making it possible to drive two squibs directly.

**(2) Squib line short-to-battery, short-to-ground and open-circuit diagnostic function (diagnostic voltage output)**

When the squib is in normal state, by an external diagnostic resistor, the device outputs a voltage derived from  $V_{CC}$  by dividing it according to the resistance ratio. Because this voltage is output via the analog multiplexer, it is possible to diagnose short-to-battery, short-to-ground and open-circuit in the squib line by a microcomputer. Also, the device contains a shunt circuit to prevent the analog multiplexer from breaking down when squib is short-to-battery.

**(3) Squib short diagnostic function (diagnostic voltage output)**

A diagnostic current is flowed from the internal constant-current source to the squib and reference resistor, and a voltage drop in each is amplified by an internal amp whose gain is the same for both. These voltages are output via the analog multiplexer, so that the squib resistance value can be diagnosed by a microcomputer. Also, the relative accuracy of the output voltages is guaranteed to be within  $\pm 10\%$ .

**(4) Squib driver MOSFET diagnostic function (diagnostic voltage output)**

When the squib driver is turned on while the safing sensor is in normal state, the MOSFET's drain voltage is output via the analog multiplexer, making it possible to diagnose the MOSFET by a microcomputer.

**(5) Diagnostic chip select function**

Since the device has a chip select function, the diagnostic control bits can be minimized when the application circuit is configured with multiple chips. Furthermore, since when a chip is not selected, diagnostic output pin AO is placed in the high-impedance state, it is possible to diagnose multiple chips using a 1-ch CPU A/D port. (Ignition operates irrespective of CS.)

**(6) Input INHIBIT function**

This function is provided to prevent erroneous ignition due to a fault in microcomputer or system power supply. It allows for ignition to be inhibited by pulling the ENB pin low.

## ABSOLUTE MAXIMUM RATING (Ta = -40~85°C)

CHARACTERISTIC	SYMBOL	RATING	UNIT
Power Supply Voltage	V <sub>BB</sub>	30	V
	V <sub>CC</sub>	10	
Input Voltage	SS	30	V
	V <sub>IN</sub>	-0.5~7	
Backup Capacitor Capacitance	CM	1500 (1ch)	μF
Backup Capacitor Charging Voltage	CV	25	V
Squib ON-Time	t <sub>ON</sub>	15	ms
Squib Driver Current (channel)	I <sub>SQ</sub>	10	A
Power Dissipation	P <sub>D</sub>	0.8	W
Operating Temperature	T <sub>ope</sub>	-40~85	°C
Junction Temperature	T <sub>j</sub>	150	°C
Storage Temperature	T <sub>stg</sub>	-55~150	°C

(Note) The squib driver uses a 60V tolerant output device. However, this does not guarantee that the squib tolerates 60V because this varies with the withstand voltages of peripheral circuits.

## ELECTRICAL CHARACTERISTICS (Ta = -40~85°C)

CHARACTERISTIC	SYMBOL	TEST CONDITION	MIN	TYP.	MAX	UNIT	
Operating Supply Voltage	V <sub>BB</sub>	—	4	—	25	V	
	V <sub>CC</sub>	—	4.75	—	5.25		
Current Consumption	I <sub>BB</sub>	V <sub>BB</sub> = 24V, when diagnosed, CCRef = 20kΩ	—	35	100	mA	
		V <sub>BB</sub> = 24V, when not diagnosed	—	0.1	1		
	I <sub>CC</sub>	V <sub>CC</sub> = 5.25V, when diagnosed	—	5	10		
		V <sub>CC</sub> = 5.25V, when not diagnosed	—	3	6		
Input Voltage	V <sub>IL</sub>	INPUT "L"	—	—	V <sub>CC</sub> × 0.3	V	
	V <sub>IH</sub>	INPUT "H"	V <sub>CC</sub> × 0.7	—	—		
Input Current	I <sub>IL</sub>	V <sub>IN</sub> = 0V (Pull-down)	—	—	± 10	μA	
		V <sub>IN</sub> = 0V (Pull-up)	—	- 50	- 200		
	I <sub>IH</sub>	V <sub>IN</sub> = V <sub>CC</sub> (Pull-down)	—	50	200		
		V <sub>IN</sub> = V <sub>CC</sub> (Pull-up)	—	—	± 10		
Squib Driver ON-Resistance	R <sub>DS (ON) SQ</sub>	V <sub>BB</sub> = 9V, V <sub>CC</sub> = 4.75V, I <sub>D</sub> = 1A	—	0.6	1	Ω	
		V <sub>BB</sub> = 9V, V <sub>CC</sub> = 4.75V, I <sub>D</sub> = 3A	—	0.7	1.2		
Squib Driver Output Leakage Current	High Side	I <sub>OLSQ (H)</sub>	V <sub>OUT</sub> = 25V	—	—	0.1	mA
	Low Side	I <sub>OLSQ (L)</sub>	V <sub>OUT</sub> = V <sub>CC</sub>	—	—	0.1	
			V <sub>OUT</sub> = 25V	—	—	1	
Diagnostic Amp Amplification Factor	AMPGAIN	V <sub>CC</sub> = 4.75V, AMPVCOMM = 3V, 25°C	18	20	22		
Diagnostic Amp Offset Voltage	AMPOFFSET	V <sub>CC</sub> = 4.75V, AMPVCOMM = 3V, 25°C	—	—	± 10	mV	
Diagnostic Amp Differential Input Voltage Range	AMPVDEF	V <sub>CC</sub> = 4.75V, I <sub>SH</sub> = 100mA, AMPVCOMM = 3V, 25°C	200	—	—	mV	
Diagnostic Amp In-phase Input Voltage Range	AMPVCOMM		3.0	—	—	V	
Diagnostic Amp Output Saturation Voltage	VAMPSAT		V <sub>CC</sub> -1	—	—	V	
Diagnostic Constant-current Source	ISHDIAGCC	CCRef = 20kΩ	28	35	45	mA	
Diagnostic Output Voltage	VDIAGSQ	RSQ = 2Ω, I <sub>SH</sub> = 35mA, IAO = 5μA	900	1400	1900	mV	
	VDIAGREF	RREF = 2Ω, I <sub>SH</sub> = 35mA, IAO = 5μA	900	1400	1900		
Diagnostic Output Relative Accuracy	VDIAGDEV	RSQ = RREF = 2Ω, I <sub>SH</sub> = 35mA, IAO = 5μA	- 10	0	10	%	



CHARACTERISTIC		SYMBOL	TEST CONDITION	MIN	TYP.	MAX	UNIT
Diagnostic Resistance Value		R1		40	80	280	kΩ
		R2		10	20	70	
Diagnostic Voltage Dividing Ratio		VDIV		0.17	0.2	0.23	—
Diagnostic Resistance Relative Accuracy		RDEV	(Measured between SS1, SQ1 -, SS2, SQ2 -)	- 5	0	5	%
Switching Time (High-side SW)		TPLH	V <sub>BB</sub> = 25V, R load, I <sub>D</sub> = 3A	—	100	200	μs
		TPHL		—	10	50	
Switching Time (Low-side SW)		TPLH		—	10	50	
		TPHL		—	10	50	
Diagnosis Switchover Time	High-side Driver Diagnosis	TDLH	V <sub>BB</sub> = 25V, R load, R = 2Ω	—	120	250	μs
		TDHL		—	50	100	
	Low-side Driver Diagnosis	TDLH		—	20	80	
		TDHL		—	40	80	
	Other Diagnosis	TDLH		—	30	60	
		TDHL		—	50	100	

(Note) The short diagnosis monitor current in cases when the CCADJ pin is shorted to GND is 100mA (Max) (at all temperatures).

(Note) Short diagnosis must be completed within 15ms.

**OUTLINE DRAWING**  
SSOP24-P-300-1.00B

Unit : mm

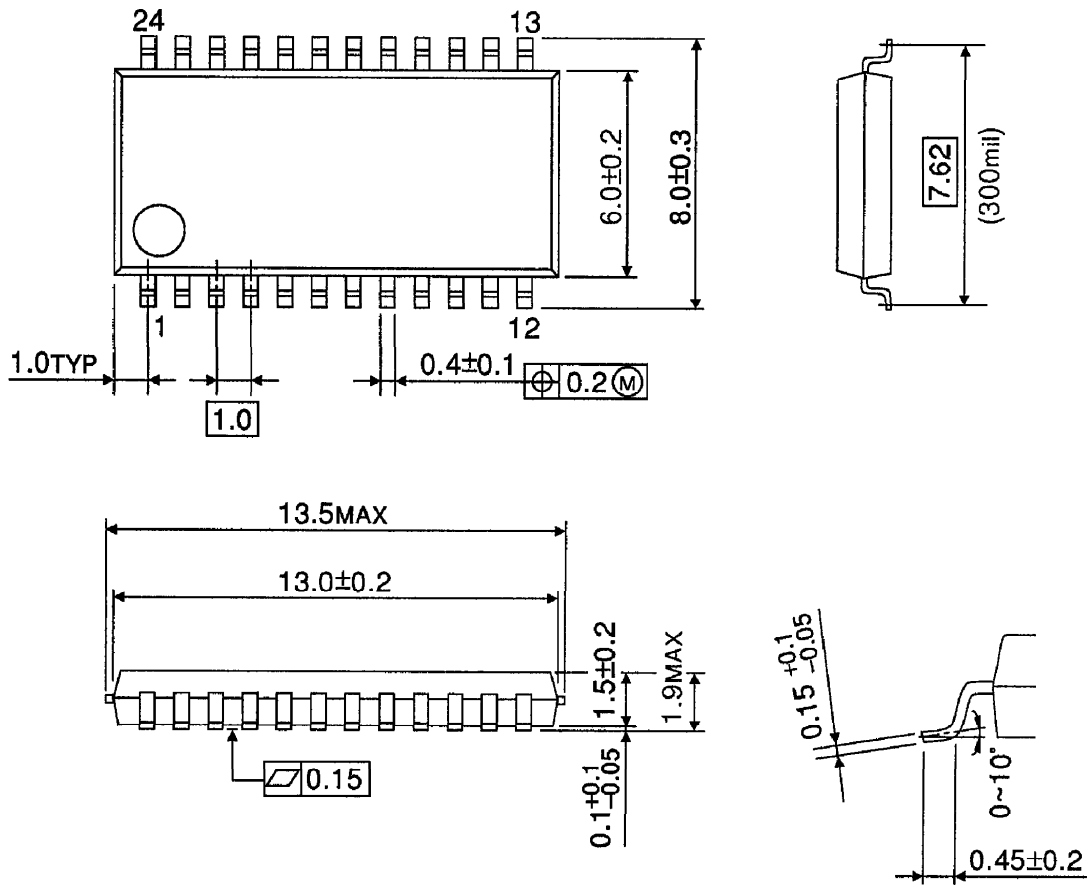

Weight : 0.29g (Typ.)