

# DATA SHEET

## **PDIUSB11**

USB device with serial interface

Product specification  
Supersedes data of 1999 Nov 19

1999 Jul 22



# USB device with serial interface

# PDIUSB11

## FEATURES

- Complies with the Universal Serial Bus specification Rev. 1.1
- Complies with the ACPI, OnNOW, and USB power management requirements
- Compliant with USB Human Interface Devices and Monitor Control Class
- Compliant with System Management Bus Specification Rev. 1.0
- Integrated SIE (Serial Interface Engine), FIFO memory and transceivers
- Automatic USB protocol handling
- High speed I<sup>2</sup>C Interface (up to 1 Mbit/s)
- Compatible with the PDIUSBH11 software
- Software controllable connection to USB bus (SoftConnect™)
- Low frequency 12 MHz crystal oscillator eases EMI design issues
- Programmable output clock frequency
- Bus powered capability with very low suspend current
- Controllable LazyClock output during suspend
- Single 3.3 V supply with 5 V tolerant I/O
- Available in 16-pin DIP and SO packages
- Full-scan design with high fault coverage (>99%) insures high quality
- Higher than 8 kV in-circuit ESD protection lowers cost of extra components

## DESCRIPTION

The Universal Serial Bus hub PDIUSB11 is a cost and feature-optimized USB interface device. It is used in microcontroller-based systems and communicates with the system microcontroller over the high speed I<sup>2</sup>C serial bus. This modular approach to implementing USB functions allows the designer to choose the optimum system microcontroller from the available wide variety. This flexibility cuts down the development time, risks, and costs by allowing the use of the existing architecture and the firmware investments. This results in the fastest way to develop the most cost-effective USB peripheral solutions. The PDIUSB11 is ideally suited for computer monitors, docking stations, keyboards, and many other applications that use the I<sup>2</sup>C or the SMBus-based architecture.

The PDIUSB11 conforms to the USB specification Rev. 1.1, I<sup>2</sup>C serial interface and the SMBus specifications. It is fully compliant with the Human Interface Device Class and Monitor Control Class specifications. Its low suspend power consumption along with the programmable LazyClock output allows for easy implementation of equipment that is compliant to the ACPI, OnNOW, and USB power management requirements. The low operating power allows the implementation of bus-powered function.

The PDIUSB11 is fully backward compatible to the PDIUSBH11/PDIUSBH11A software. In addition, it also incorporates the feature enhancements like SoftConnect™, LazyClock, programmable clock output, lower frequency crystal oscillator, multiple function endpoints and integration of termination resistors. All of these feature enhancements contribute to significant cost savings in the system implementation and at the same time ease the implementation of advanced USB functionality into the peripherals.

## ORDERING INFORMATION

PACKAGES	TEMPERATURE RANGE	OUTSIDE NORTH AMERICA	NORTH AMERICA	PKG. DWG. #
16-pin plastic SO	-40°C to +85°C	PDIUSB11 D	PDIUSB11 D	SOT162-1
16-pin plastic DIP	-40°C to +85°C	PDIUSB11 N	PDIUSB11 N	SOT38-4

## BLOCK DIAGRAM

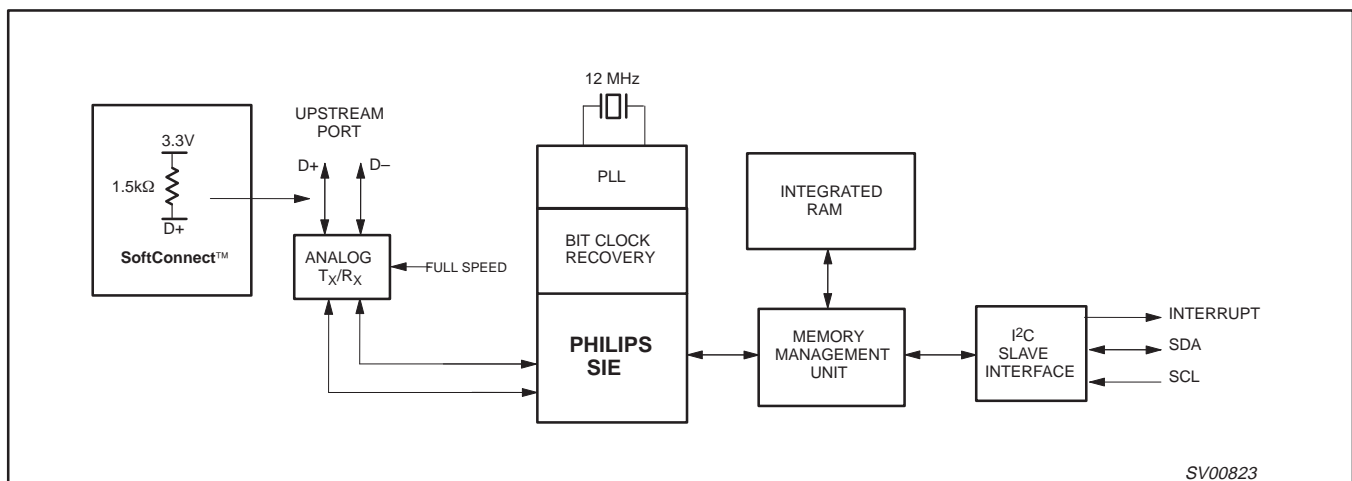

### NOTE:

1. This is a conceptual block diagram and does not include each individual signal.

# USB device with serial interface

# PDIUSB11

## Analog Transceiver

The transceiver interfaces directly to the USB cables through some termination resistors. They are capable of transmitting and receiving serial data at "full speed" (12 Mbit/s) only.

## PLL

A 12 MHz to 48 MHz clock multiplier PLL (Phase-Locked Loop) is integrated on-chip. This allows for the use of low-cost 12 MHz crystal. EMI is also minimized due to lower frequency crystal. No external components are needed for the operation of the PLL.

## Bit Clock Recovery

The bit clock recovery circuit recovers the clock from the incoming USB data stream using 4X over-sampling principle. It is able to track jitter and frequency drift specified by the USB specification.

## Philips Serial Interface Engine (PSIE)

The Philips SIE implements the full USB protocol layer. It is completely hardwired for speed and needs no firmware intervention. The functions of this block include: synchronization pattern recognition, parallel/serial conversion, bit stuffing/de-stuffing, CRC checking/generation, PID verification/generation, address recognition, handshake evaluation/generation.

## Memory Management Unit (MMU) and Integrated RAM

The MMU and the integrated RAM is used to handle the large difference in data rate between USB, running in bursts of 12 Mbit/s and the I<sup>2</sup>C interface to the microcontroller, running at up to 1 Mbit/s. This allows the microcontroller to read and write USB packets at its own speed through I<sup>2</sup>C.

## I<sup>2</sup>C Slave Interface

This block implements the necessary I<sup>2</sup>C interface protocol. A slave I<sup>2</sup>C allows for simple micro-coding. An interrupt is used to alert the microcontroller whenever the PDIUSB11 needs attention. As a slave I<sup>2</sup>C device, the PDIUSB11 I<sup>2</sup>C clock: SCL is an input and is controlled by the microcontroller. The I<sup>2</sup>C interface can run up to 1 Mbit/s.

## SoftConnect™

The connection to the USB is accomplished by bringing D+ (for high-speed USB device) high through a 1.5 kΩ pull-up resistor. In the PDIUSB11, the 1.5 kΩ pull-up resistor is integrated on-chip and is not connected to V<sub>CC</sub> by default. The connection of the internal resistor to V<sub>CC</sub> is established through a command sent by the external/system microcontroller. This allows the system microcontroller to complete its initialization sequence before deciding to establish connection to the USB. Re-initialization of the USB bus connection can also be affected without requiring the pull out of the cable.

The PDIUSB11 will check for USB VBUS availability before the connection can be established. VBUS sensing is provided through VBUS pin.

It should be noted that the tolerance of the internal resistors is higher (30%) than that specified by the USB specification (5%). However, the overall V<sub>SE</sub> voltage specification for the connection can still be met with good margin. The decision to make sure of this feature lies with the users.

SoftConnect™ is a patent pending technology from Philips Semiconductors.

## ENDPOINT DESCRIPTIONS

ENDPOINT#	ENDPOINT INDEX	TRANSFER TYPE	DIRECTION	MAX PACKET SIZE (BYTES)
0	2	Control	OUT	8
	3		IN	8
1	5	Generic	OUT	8
	4		IN	8
2	6	Generic	OUT	8
	7		IN	8
3	8	Generic	OUT	8
	9		IN	8

### NOTE:

- Generic endpoint can be used for Interrupt or Bulk endpoint.

# USB device with serial interface

# PDIUSB11

## PIN DESCRIPTION

PIN NO	PIN SYMBOL	TYPE	DRIVE	DESCRIPTION
1	TEST	Input		Connect to GND for normal operation
2	RESET_N	Input	ST	Power-on reset
3	XTAL1	Input		Crystal connection 1 (12MHz)
4	XTAL2	Output		Crystal connection 2 (12MHz)
5	CLKOUT	Output	3 mA	Programmable output clock for external devices
6	V <sub>CC</sub>	Power		Voltage supply 3.3V±0.3V
7	SUSPEND	Output	OD6	Device is in suspended state
8	INT_N	Output	OD6	Connect to microcontroller interrupt
9	SDA	I/O	OD6	I <sup>2</sup> C bi-directional data
10	SCL	I/O	OD6	I <sup>2</sup> C bit-clock
11	GND	Power		Ground reference
12	DP	AI/O		USB D+ connection
13	DM	AI/O		USB D- connection
14	AGND	Power		Analog ground reference
15	AV <sub>CC</sub>	Power		Analog voltage supply 3.3V±0.3V
16	VBUS	Input		USB VBUS sensing pin

### NOTES:

- Signals ending in \_N indicate active LOW signals.  
 ST: Schmitt Trigger  
 OD6: Open Drain with 6 mA drive  
 AI/O: Analog I/O

## APPLICATION DIAGRAM

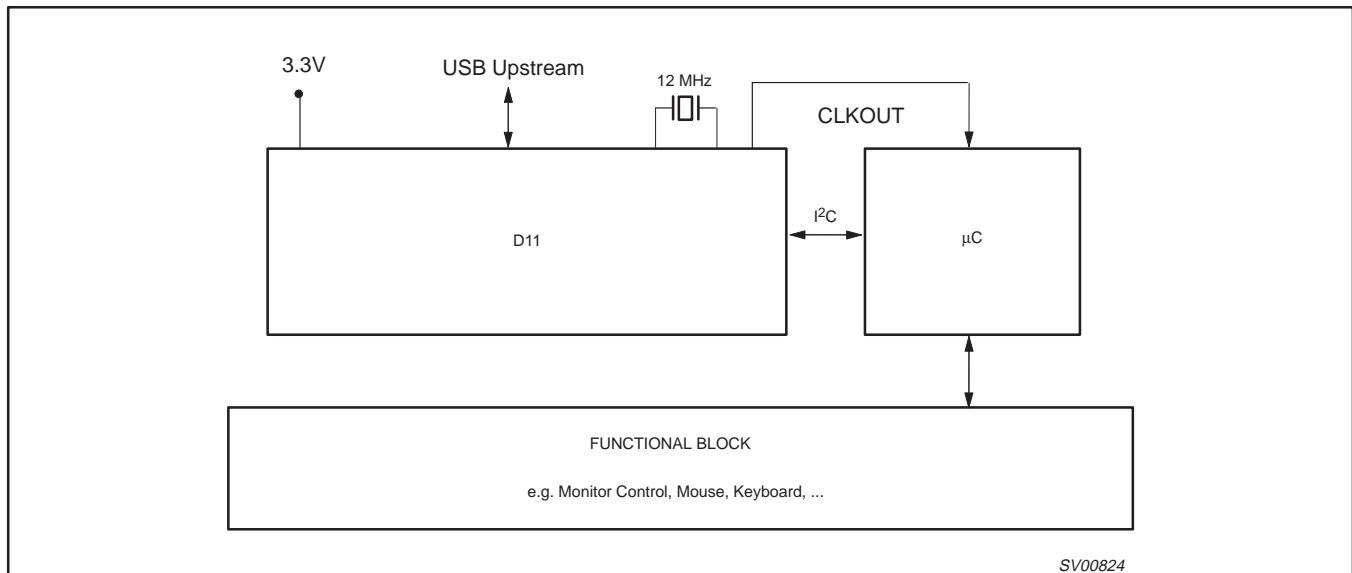

# USB device with serial interface

# PDIUSB11

## I<sup>2</sup>C Interface

The I<sup>2</sup>C bus is used to interface to an external microcontroller needed to control the operation of the USB device. For cost consideration, the target system microcontroller can be shared and utilized for both the functional part as well as the USB protocol interfacing. The PDIUSB11 implements a slave I<sup>2</sup>C interface. When the PDIUSB11 needs to communicate with the microcontroller it asserts an interrupt signal. The microcontroller services this interrupt by reading the appropriate status register on the PDIUSB11 through the I<sup>2</sup>C bus. (For more information about the I<sup>2</sup>C serial bus, refer to the *I<sup>2</sup>C Handbook*, Philips order number 9397 750 00013).

The I<sup>2</sup>C interface on the PDIUSB11 defines two types of transactions:

- **command transaction** – A command transaction is used to define which data (e.g., status byte, buffer data, ...) will be read from/written to the USB interface in the next data transaction. A data transaction usually follows a command transaction.
- **data transaction** – A data transaction reads data from/writes data to the USB interface. The meaning of the data is dependent on the command transaction which was sent before the data transaction.

Two addresses are used to differentiate between command and data transactions. Writing to the command address is interpreted as a command, while reading from/writing to the data address is used to transfer data between the PDIUSB11A and the controller.

## ADDRESS TABLE

Type of Address	Physical Address MSB to LSB (Binary)
Command	0011 011
Data	0011 010

## Protocol

An I<sup>2</sup>C transaction starts with a Start Condition, followed by an address. When the address matches either the command or data address the transaction starts and runs until a Stop Condition or another Start Condition (repeated start) occurs.

The command address is write-only and is unable to do a read. The next bytes in the message are interpreted as commands. Several command bytes can be sent after one command address. Each of the command bytes is acknowledged and passed on to the Memory Management Unit inside the PDIUSB11.

When the Start Condition address matches the data address, the next bytes are interpreted as data. When the RW bit in the address indicates a *master writes data to slave* (=‘0’) the bytes are received, acknowledged and passed on to the Memory Management Unit. If the RW bit in the address indicates a *master reads data from slave* (=‘1’) the PDIUSB11 will send data to the master. The I<sup>2</sup>C-master must acknowledge all data bytes except the last one. In this way the I<sup>2</sup>C interface knows when the last byte has been transmitted and it then releases the SDA line so that the master controller can generate the Stop Condition.

Repeated start support allows another packet to be sent without generating a Stop Condition.

## Timing

The I<sup>2</sup>C interface in the PDIUSB11 can support clock speeds up to 1 MHz.

## USB device with serial interface

## PDIUSB11

**COMMAND SUMMARY**

Some commands have the same command code (e.g., Read Buffer and Write Buffer). In these cases, the direction of the Data Phase (read or write) indicates which command is executed.

COMMAND NAME	RECIPIENT	CODING	DATA PHASE
<b>Initialization Commands</b>			
Set Address/Enable	Function	D1h	Write 1 byte
Set Endpoint Enable	Function	D8h	Write 1 byte
Set Mode	Function	F3h	Write 2 byte
<b>Data Flow Commands</b>			
Read Interrupt Register		F4h	Read 2 bytes
Select Endpoint	Control OUT Endpoint	00h	Read 1 byte (optional)
	Control IN Endpoint	01h	Read 1 byte (optional)
	Other Endpoints	00h+Endpoint Index	Read 1 byte (optional)
Read Last Transaction Status	Control OUT Endpoint	40h	Read 1 byte
	Control IN Endpoint	41h	Read 1 byte
	Other Endpoints	40h+Endpoint Index	Read 1 byte
Read Endpoint Status	Control OUT Endpoint	80h	Read 1 byte
	Control IN Endpoint	81h	Read 1 byte
	Other Endpoints	80h+Endpoint Index	Read 1 byte
Read Buffer	Selected Endpoint	F0h	Read n bytes
Write Buffer	Selected Endpoint	F0h	Write n bytes
Set Endpoint Status	Control OUT Endpoint	40h	Write 1 byte
Set Endpoint Status	Control IN Endpoint	41h	Write 1 byte
	Other Endpoints	40h+Endpoint Index	Write 1 byte
Acknowledge Setup	Selected Endpoint	F1h	None
Clear Buffer	Selected Endpoint	F2h	None
Validate Buffer	Selected Endpoint	FAh	None
<b>General Commands</b>			
Send Resume		F6h	None
Read Current Frame Number		F5h	Read 1 or 2 bytes

# USB device with serial interface

# PDIUSB11

## COMMAND DESCRIPTIONS

### Command Procedure

There are three basic types of commands: Initialization, Data Flow, and General commands. Respectively, these are used to initialize the function; for data flow between the function and the host; and some general commands.

### Initialization Commands

Initialization commands are used during the enumeration process of the USB network. These commands are used to enable the function endpoints. They are also used to set the USB assigned address.

#### Set Address / Enable

**Command** : D1h, (Function)  
**Data** : Write 1 byte

This command is used to set the USB assigned address and enable the function.

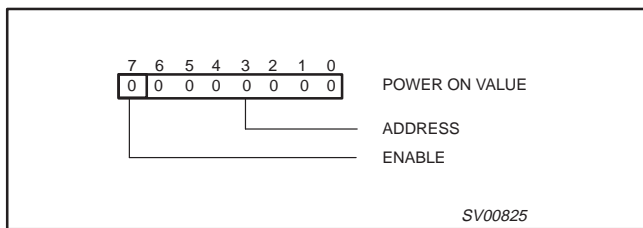

**Address** The value written becomes the address.  
**Enable** A '1' enables this function.

#### Set Endpoint Enable

**Command** : D8h  
**Data** : Write 1 byte

The generic endpoints can only be enabled when the function is enabled via the Set Address/Enable command.

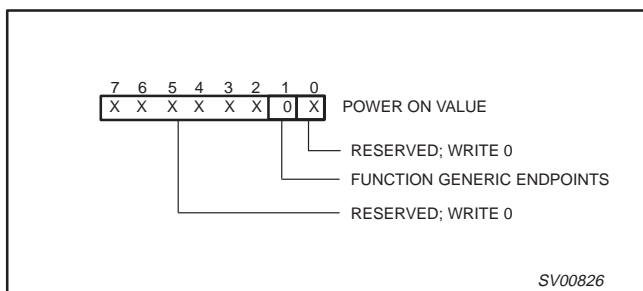

**Function Generic Endpoint** A value of '1' indicates the function generic endpoints are enabled.

#### Set Mode

**Command** : F3h  
**Data** : Write 2 bytes

The Set Mode command is followed by two data writes. The first byte contains the configuration byte values. The second byte is the clock division factor byte.

#### Configuration Byte

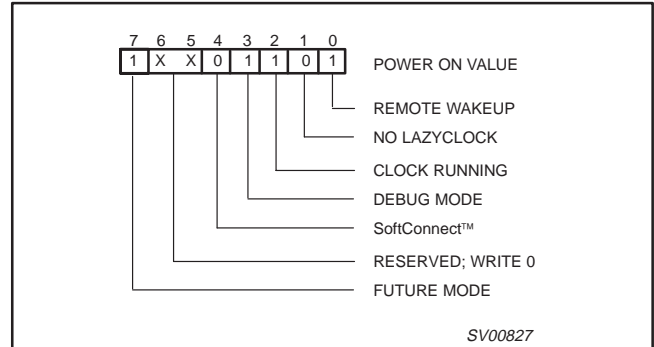

- Remote Wakeup** A '1' indicates that a remote wakeup feature is ON. Bus reset will set this bit to '1'.
- No LazyClock** A '1' indicates that CLKOUT will not switch to LazyClock. A '0' indicates that the CLKOUT switches to LazyClock 1ms after the Suspend pin goes high. LazyClock frequency is 30KHz ±40%. The programmed value will not be changed by a bus reset.
- Clock Running** A '1' indicates that the internal clocks and PLL are always running even during Suspend state. A '0' indicates that the internal clock, crystal oscillator and PLL are stopped whenever not needed. To meet the strict Suspend current requirement, this bit needs to be set to '0'. The programmed value will not be changed by a bus reset.
- Debug Mode** A '1' indicates that all errors and "NAKING" are reported and a '0' indicates that only OK and babbling are reported. The programmed value will not be changed by a bus reset.
- SoftConnect™** A '1' indicates that the upstream pull-up resistor will be connected if VBUS is available. A '0' means that the upstream resistor will not be connected. The programmed value will not be changed by a bus reset.
- FutureMode** Write a '1'.

# USB device with serial interface

# PDIUSB11

### Clock Division Factor Byte

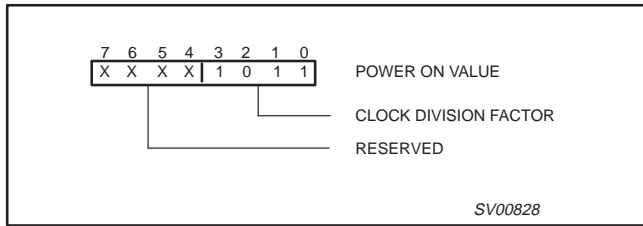

**Clock Division Factor** The value indicates clock division factor for CLKOUT. The output frequency is  $48 \text{ MHz}/(N+1)$  where N is the Clock Division Factor. The reset value is 11. This will produce the output frequency of 4 MHz which can then be programmed up (or down) by the user. The minimum value is one giving the range of frequency from 4 to 24 MHz. The PDIUSB11 design ensures no glitching during frequency change. The programmed value will not be changed by a bus reset.

### Data Flow Commands

Data flow commands are used to manage the data transmission between the USB endpoints and the monitor. Much of the data flow is initiated via an interrupt to the microcontroller. The microcontroller utilizes these commands to access and determine whether the endpoint FIFOs have valid data.

### Read Interrupt Register

**Command** : F4h  
**Data** : Read 2 bytes

### Interrupt Register Byte 1

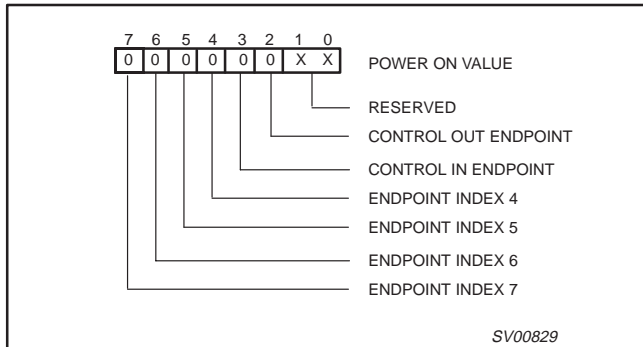

This command indicates the origin of an interrupt. A '1' indicates an interrupt occurred at this endpoint. The bits are cleared by reading the endpoint status register through the Read Endpoint Status command.

After a bus reset, an interrupt will be generated and bit 6 of the Interrupt Register Byte 2 will be '1'. The interrupt is internally cleared by reading the interrupt register. A bus reset is completely identical to the hardware reset through the RESET\_N pin with the sole difference of interrupt notification.

### Interrupt Register Byte 2

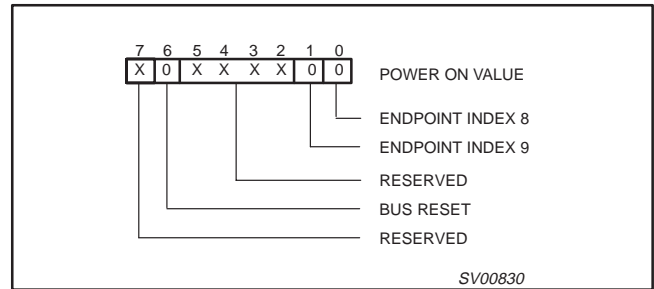

### Select Endpoint

**Command** : 00-0Dh  
**Data** : Optional Read 1 byte

The Select Endpoint command initializes an internal pointer to the start of the Selected buffer. Optionally, this command can be followed by a data read, which returns '0' if the buffer is empty and '1' if the buffer is full.

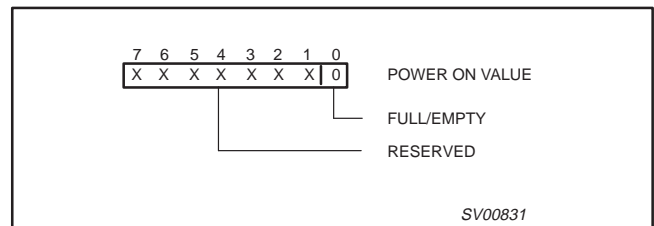

**Full/Empty** A '1' indicates the buffer is full, '0' indicates an empty buffer.



# USB device with serial interface

# PDIUSB11

## Read Last Transaction Status

**Command** : 40-4Dh  
**Data** : Read 1 byte

The Read Last Transaction Status command is followed by one data read that returns the status of the last transaction of the endpoint. This command also resets the corresponding interrupt flag in the interrupt register, and clears the status, indicating that it was read.

This command is useful for debugging purposes. Since it keeps track of every transaction, the status information is overwritten for each new transaction.

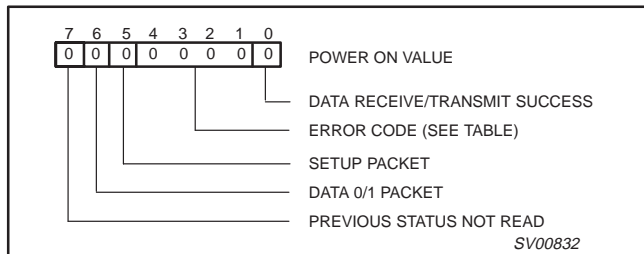

- Data Receive/Transmit Success** A '1' indicates data has been received or transmitted successfully.
- Error Code** See Table 1, Error Codes.
- Setup Packet** A '1' indicates the last successful received packet had a SETUP token (this will always read '0' for IN buffers).
- Data 0/1 Packet** A '1' indicates the last successful received or sent packet had a DATA1 PID.
- Previous Status not Read** A '1' indicates a second event occurred before the previous status was read.

**Table 1. ERROR CODES**

ERROR CODE	RESULT
0000	No Error
0001	PID encoding Error; bits 7-4 are not the inversion of bits 3-0
0010	PID unknown; encoding is valid, but PID does not exist
0011	Unexpected packet; packet is not of the type expected (= token, data or acknowledge), or SETUP token to a non-control endpoint
0100	Token CRC Error
0101	Data CRC Error
0110	Time Out Error
0111	Babble Error
1000	Unexpected End-of-packet
1001	Sent or received NAK
1010	Sent Stall, a token was received, but the endpoint was stalled
1011	Overflow Error, the received packet was longer than the available buffer space
1101	Bitstuff Error
1111	Wrong DATA PID; the received DATA PID was not the expected one

## Read Endpoint Status

**Command** : 80-8Dh  
**Data** : Read 1 byte

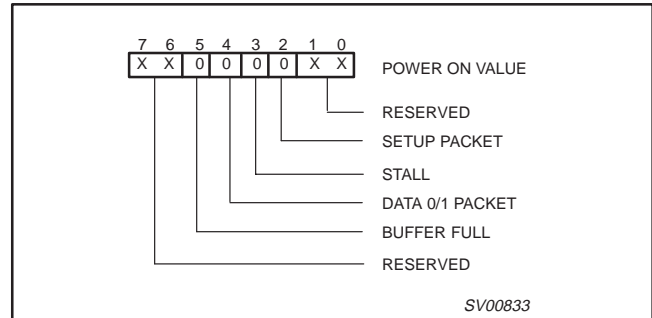

- Setup Packet** A '1' indicates the last received packet had a SETUP token.
- STALL** A '1' indicates the endpoint is stalled.
- Data 0/1 Packet** A '1' indicates if the last received or sent packet had a DATA1 PID.
- Buffer Full** A '1' indicates that the buffer is full.

## Read Buffer

**Command** : F0h  
**Data** : Read multiple bytes (max 10)

The Read Buffer command is followed by a number of data reads, which return the contents of the selected endpoint data buffer. After each read, the internal buffer pointer is incremented by 1.

The buffer pointer is not reset to the buffer start by the Read Buffer command. This means that reading or writing a buffer can be interrupted by any other command (except for Select Endpoint), or can be done by more than one I<sup>2</sup>C transaction (read the first 2 bytes to get the number of data bytes, then read the rest in other transactions).

The data in the buffer are organized as follows:

- byte 0: Reserved: can have any value
- byte 1: Number/length of data bytes
- byte 2: Data byte 1
- byte 3: Data byte 2
- .....

## Write Buffer

**Command** : F0h  
**Data** : Write multiple bytes (max 10)

The Write Buffer command is followed by a number of data writes, which load the endpoints buffer. The data must be organized in the same way as described in the Read Buffer command. The first byte (reserved) should always be '0'. As in the Read Buffer command, the data can be split up into different I<sup>2</sup>C data transactions.

### WARNING:

There is no protection against writing or reading over a buffer's boundary or against writing into an OUT buffer or reading from an IN buffer. Any of these actions could cause an incorrect operation. Data in an OUT buffer are only meaningful after a successful transaction.

# USB device with serial interface

# PDIUSB11

## Clear Buffer

**Command** : F2h  
**Data** : None

When a packet is received completely, an internal endpoint buffer full flag is set. All subsequent packets will be refused by returning a NAK. When the microcontroller has read the data, it should free the buffer by the Clear Buffer command. When the buffer is cleared, new packets will be accepted.

## Validate Buffer

**Command** : FAh  
**Data** : None

When the microprocessor has written data into an IN buffer, it should set the buffer full flag by the Validate Buffer command. This indicates that the data in the buffer are valid and can be sent to the host when the next IN token is received.

## Set Endpoint Status

**Command** : 40-4Dh  
**Data** : Write 1 byte

A stalled control endpoint is automatically unstalled when it receives a SETUP token, regardless of the content of the packet. If the endpoint should stay in its stalled state, the microcontroller can re-stall it.

When a stalled endpoint is unstalled (either by the Set Endpoint Status command or by receiving a SETUP token), it is also re-initialized. This flushes the buffer and if it is an OUT buffer it waits for a DATA 0 PID, if it is an IN buffer it writes a DATA 0 PID.

Even when unstalled, writing Set Endpoint Status to '0' initializes the endpoint.

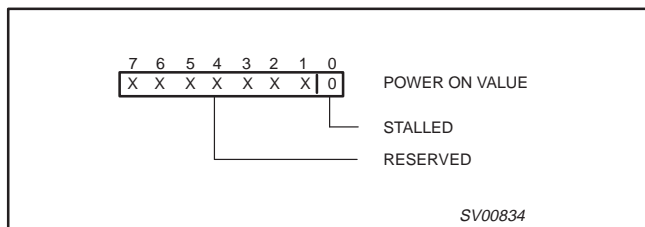

Stalled A '1' indicates the endpoint is stalled.

## Acknowledge Setup

**Command** : F1h  
**Data** : None

The arrival of a SETUP packet flushes the IN buffer and disables the Validate Buffer and Clear Buffer commands for both IN and OUT endpoints.

The microcontroller needs to re-enable these commands by the Acknowledge Setup command. This ensures that the last SETUP packet stays in the buffer and no packet can be sent back to the host until the microcontroller has acknowledged explicitly that it has seen the SETUP packet.

The microcontroller must send the Acknowledge Setup command to both the IN and OUT endpoints.

## GENERAL COMMANDS

### Send Resume

**Command** : F6h  
**Data** : None

Sends an upstream resume signal for 10 ms. This command is normally issued when the device is in suspend. The RESUME command is not followed by a data read or write.

### Read Current Frame Number

**Command** : F5h  
**Data** : Read One or Two Bytes

This command is followed by one or two data reads and returns the frame number of the last successfully received SOF. The frame number is returned Least Significant Byte first.

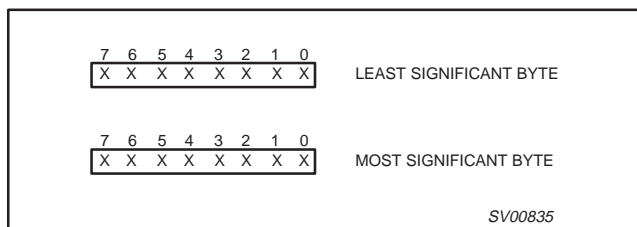

## USB device with serial interface

## PDIUSB11

## RECOMMENDED OPERATING CONDITIONS

SYMBOL	PARAMETER	TEST CONDITIONS	MIN	MAX	UNIT
$V_{CC}$	DC supply voltage		3.0	3.6	V
$V_I$	DC input voltage range		0	5.5	V
$V_{I/O}$	DC input voltage range for I/O		0	5.5	V
$V_{AI/O}$	DC input voltage range for analog I/O		0	$V_{CC}$	V
$V_O$	DC output voltage range		0	$V_{CC}$	V
$T_{amb}$	Operating ambient temperature range in free air	See DC and AC characteristics per device	-40	85	°C

ABSOLUTE MAXIMUM RATINGS<sup>1</sup>

SYMBOL	PARAMETER	TEST CONDITIONS	MIN	MAX	UNIT
$V_{CC}$	DC supply voltage		-0.5	+4.6	V
$I_{IK}$	DC input diode current	$V_I < 0$		-50	mA
$V_I$	DC input voltage	Note 2	-0.5	+5.5	V
$V_{I/O}$	DC input voltage range for I/O		-0.5	$V_{CC} + 0.5$	V
$I_{OK}$	DC output diode current	$V_O > V_{CC}$ or $V_O < 0$		±50	mA
$V_O$	DC output voltage	Note 2	-0.5	$V_{CC} + 0.5$	V
$I_O$	DC output sink or source current for other pins	$V_O = 0$ to $V_{CC}$		±15	mA
$I_O$	DC output sink or source current for D+/D- pins	$V_O = 0$ to $V_{CC}$		±50	mA
$I_{GND}, I_{CC}$	DC $V_{CC}$ or GND current			±100	mA
$T_{STG}$	Storage temperature range		-60	+150	°C
$P_{TOT}$	Power dissipation per package				

## NOTES:

- Stresses beyond those listed may cause damage to the device. These are stress ratings only and functional operation of the device at these or any other conditions beyond those listed in the RECOMMENDED OPERATING CONDITIONS table is not implied. Exposure to absolute maximum rated conditions for extended periods may affect device reliability.
- The input and output voltage ratings may be exceeded if the input and output current ratings are observed.

## DC CHARACTERISTICS (Digital pins)

SYMBOL	PARAMETER	TEST CONDITIONS	MIN	TYP	MAX	UNIT
<b>Input Levels</b>						
$V_{IL}$	LOW level input voltage				0.6	V
$V_{IH}$	HIGH level input voltage		2.7			V
$V_{TLH}$	LOW to HIGH threshold voltage	ST (Schmitt Trigger) pins	1.4		1.9	V
$V_{THL}$	HIGH to LOW threshold voltage	ST pins	0.9		1.5	V
$V_{HYS}$	Hysteresis voltage	ST pins	0.4		0.7	V
<b>Output Levels</b>						
$V_{OL}$	LOW level output voltage	$I_{OL} = \text{rated drive}$			0.4	V
		$I_{OL} = 20 \mu\text{A}$			0.1	V
$V_{OH}$	HIGH level output voltage	$I_{OH} = \text{rated drive}$	2.4			V
		$I_{OH} = 20 \mu\text{A}$	$V_{CC} - 0.1$			V
<b>Leakage Current</b>						
$I_{OZ}$	OFF state current	OD (Open Drain) pins			±5	μA
$I_L$	Input leakage current				±5	μA
$I_S$	Suspend current	Oscillator stopped & inputs to GND/ $V_{CC}$			15	μA
$I_O$	Operating current	I <sup>2</sup> C operating		10		mA

# USB device with serial interface

# PDIUSB11

## DC CHARACTERISTICS (A/I/O pins)

SYMBOL	PARAMETER	TEST CONDITIONS	MIN	MAX	UNIT
<b>Leakage Current</b>					
$I_{LO}$	Hi-Z state data line leakage	$0V < V_{IN} < 3.3V$		$\pm 10$	$\mu A$
<b>Input Levels</b>					
$V_{DI}$	Differential input sensitivity	$ (D+) - (D-) ^1$	0.2		V
$V_{CM}$	Differential common mode range	Includes $V_{DI}$ range	0.8	2.5	V
$V_{SE}$	Single-ended receiver threshold		0.8	2.0	V
<b>Output Levels</b>					
$V_{OL}$	Static output LOW	$R_L$ of 1.5k $\Omega$ to 3.6V		0.3	V
$V_{OH}$	Static output HIGH	$R_L$ of 15k $\Omega$ to GND	2.8	3.6	V
<b>Capacitance</b>					
$C_{IN}$	Transceiver capacitance	Pin to GND		20	pF
<b>Output Resistance</b>					
$Z_{DRV}^2$	Driver output resistance	Steady state drive	29	44	$\Omega$
<b>Integrated Resistance</b>					
$Z_{PU}$	Pull-up resistance	SoftConnect™ = ON	1.1	1.9	k $\Omega$
$Z_{PD}$	Pull-down resistance	Pull-down = ON	11	19	k $\Omega$

**NOTES:**

- D+ is the symbol for the USB positive data pin; DP.  
D- is the symbol for the USB negative data pin; DM.
- Includes external resistors of 22  $\Omega \pm 1\%$  each on D+ and D-.

## LOAD FOR D+/D-

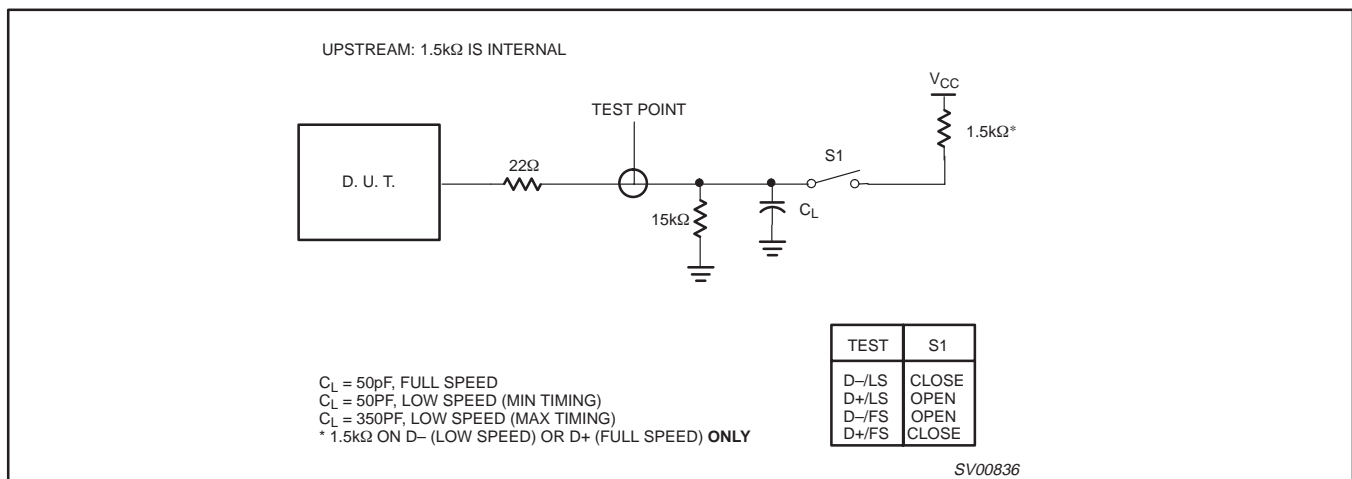

USB device with serial interface

PDIUSB11

AC CHARACTERISTICS (A/I/O pins, FULL speed)

SYMBOL	PARAMETER	TEST CONDITIONS	MIN	MAX	UNIT
<b>Driver characteristics</b>		$C_L = 50 \text{ pF};$ $R_{pu} = 1.5 \text{ k}\Omega$ on D+ to $V_{CC}$			
$t_r$	Transition Time: Rise time	Between 10% and 90%	4	20	ns
$t_f$	Fall time		4	20	ns
$t_{RFM}$	Rise/fall time matching	$(t_r/t_f)$	90	110	%
$V_{CRS}$	Output signal crossover voltage		1.3	2.0	V
<b>Driver Timings</b>					
$t_{EOPT}$	Source EOP width	Figure 1	160	175	ns
$t_{DEOP}$	Differential data to EOP transition skew	Figure 1	-2	5	ns
<b>Receiver Timings</b>					
$t_{JR1}$	Receiver Data Jitter Tolerance To next transition	Characterized and not tested. Guaranteed by design.	-18.5	18.5	ns
$t_{JR2}$	For paired transitions		-9	9	ns
$t_{EOPR1}$	EOP Width at Receiver Must reject as EOP	Figure 1	40		ns
$t_{EOPR2}$	Must accept		82		ns

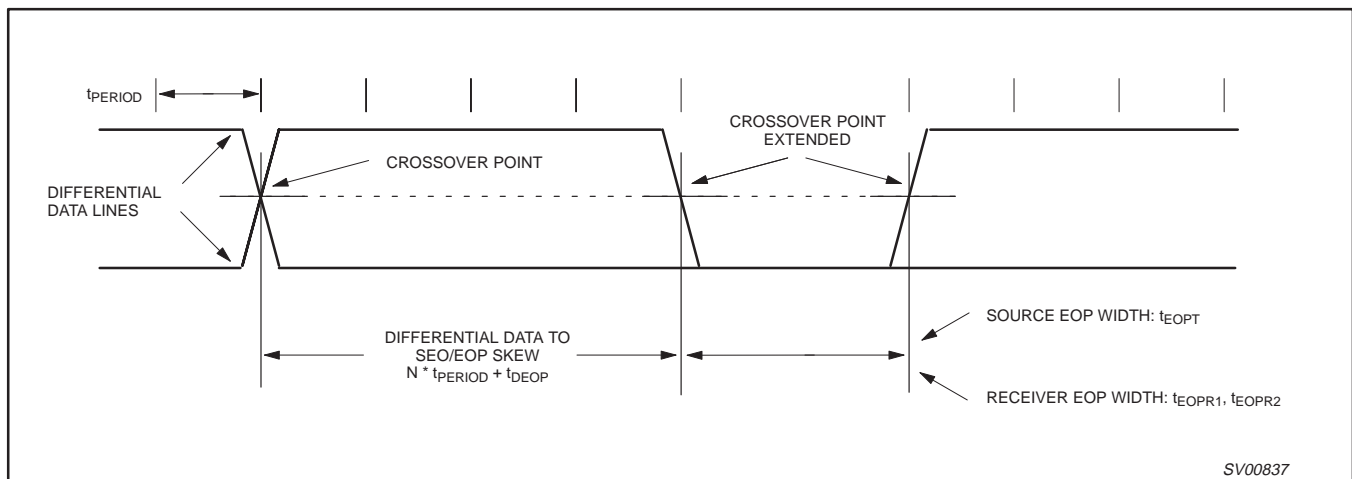

Figure 1. Differential data to EOP transition skew and EOP width

# USB device with serial interface

# PDIUSB11

## AC CHARACTERISTICS (I<sup>2</sup>C pins)

All timing values are valid within the operating supply voltage and ambient temperature range and reference to  $V_{IL}$  and  $V_{IH}$  with an input voltage swing of  $V_{SS}$  and  $V_{DD}$ .

SYMBOL	PARAMETER	TEST CONDITIONS	MIN	MAX	UNIT
$F_{SCL}$	SCL clock frequency			1000	kHz
$t_{BUF}$	Bus free time		0.5		$\mu$ s
$t_{SU;STA}$	Start condition set-up time		0.25		$\mu$ s
$t_{HD;STA}$	Start condition hold time		0.25		$\mu$ s
$t_{LOW}$	SCL LOW time		0.45		$\mu$ s
$t_{HIGH}$	SCL HIGH time		0.45		$\mu$ s
$t_r$	SCL and S <sub>DA</sub> rise time			0.3	$\mu$ s
$t_f$	SCL and S <sub>DA</sub> fall time			0.1	$\mu$ s
$t_{SU;DAT}$	Data set-up time		100		ns
$t_{HD;DAT}$	Data hold time		0		ns
$t_{VD;DAT}$	SCL LOW to data out valid			0.4	$\mu$ s
$t_{SU;STO}$	Stop condition set-up time		0.25		$\mu$ s

A detailed description of the I<sup>2</sup>C-bus specification, with applications, is given in the brochure "The I<sup>2</sup>C-bus and how to use it". This brochure may be ordered using the Philips order number 9398 393 40011.

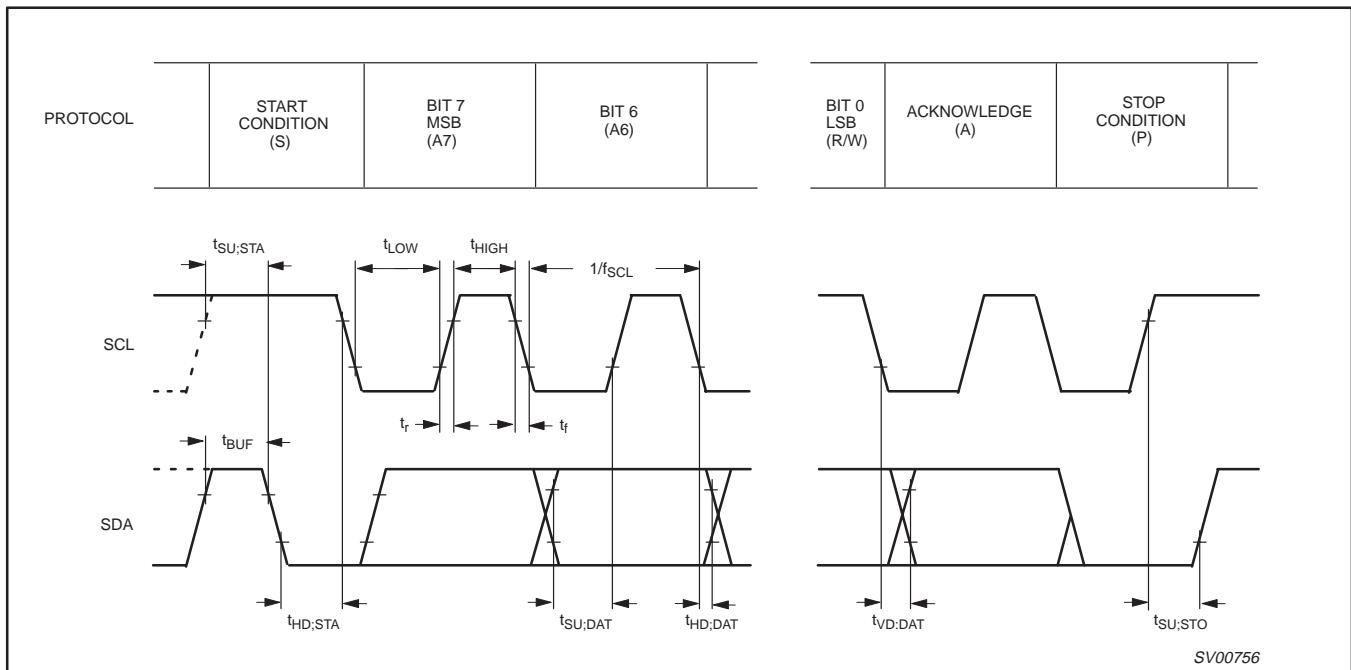

Figure 2. I<sup>2</sup>C-bus timing diagram

USB device with serial interface

PDIUSB11

SO16: plastic small outline package; 16 leads; body width 7.5 mm

SOT162-1

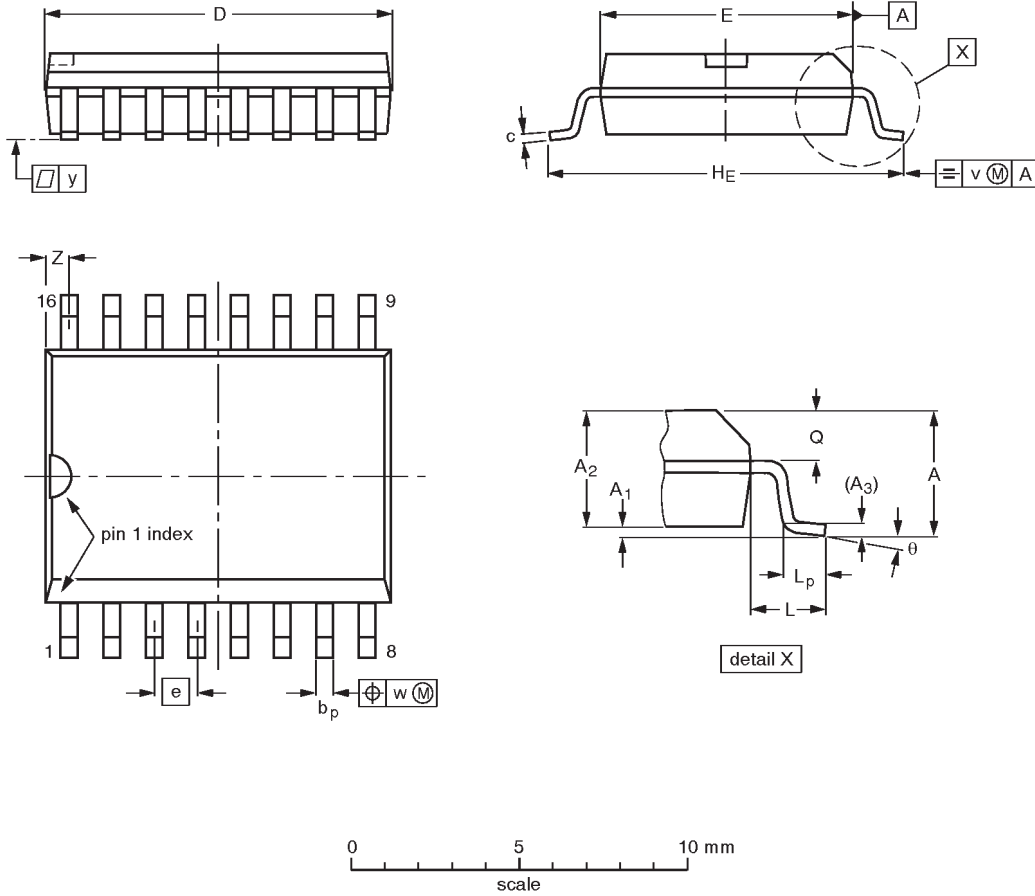

DIMENSIONS (inch dimensions are derived from the original mm dimensions)

UNIT	A max.	A <sub>1</sub>	A <sub>2</sub>	A <sub>3</sub>	b <sub>p</sub>	c	D <sup>(1)</sup>	E <sup>(1)</sup>	e	H <sub>E</sub>	L	L <sub>p</sub>	Q	v	w	y	Z <sup>(1)</sup>	θ
mm	2.65	0.30 0.10	2.45 2.25	0.25	0.49 0.36	0.32 0.23	10.5 10.1	7.6 7.4	1.27	10.65 10.00	1.4	1.1 0.4	1.1 1.0	0.25	0.25	0.1	0.9 0.4	8° 0°
inches	0.10	0.012 0.004	0.096 0.089	0.01	0.019 0.014	0.013 0.009	0.41 0.40	0.30 0.29	0.050	0.42 0.39	0.055	0.043 0.016	0.043 0.039	0.01	0.01	0.004	0.035 0.016	

Note

1. Plastic or metal protrusions of 0.15 mm maximum per side are not included.

OUTLINE VERSION	REFERENCES				EUROPEAN PROJECTION	ISSUE DATE
	IEC	JEDEC	EIAJ			
SOT162-1	075E03	MS-013AA				-92-11-17 95-01-24

USB device with serial interface

PDIUSB11

DIP16: plastic dual in-line package; 16 leads (300 mil)

SOT38-4



DIMENSIONS (inch dimensions are derived from the original mm dimensions)

UNIT	A max.	A <sub>1</sub> min.	A <sub>2</sub> max.	b	b <sub>1</sub>	b <sub>2</sub>	c	D <sup>(1)</sup>	E <sup>(1)</sup>	e	e <sub>1</sub>	L	M <sub>E</sub>	M <sub>H</sub>	w	Z <sup>(1)</sup> max.
mm	4.2	0.51	3.2	1.73 1.30	0.53 0.38	1.25 0.85	0.36 0.23	19.50 18.55	6.48 6.20	2.54	7.62	3.60 3.05	8.25 7.80	10.0 8.3	0.254	0.76
inches	0.17	0.020	0.13	0.068 0.051	0.021 0.015	0.049 0.033	0.014 0.009	0.77 0.73	0.26 0.24	0.10	0.30	0.14 0.12	0.32 0.31	0.39 0.33	0.01	0.030

Note

1. Plastic or metal protrusions of 0.25 mm maximum per side are not included.

OUTLINE VERSION	REFERENCES				EUROPEAN PROJECTION	ISSUE DATE
	IEC	JEDEC	EIAJ			
SOT38-4						92-11-17 95-01-14



# USB device with serial interface

# PDIUSB11

## SOLDERING

### Introduction

This text gives a very brief insight to a complex technology. A more in-depth account of soldering ICs can be found in our *"Data Handbook IC26; Integrated Circuit Packages"* (document order number 9398 652 90011).

There is no soldering method that is ideal for all IC packages. Wave soldering is often preferred when through-hole and surface mount components are mixed on one printed circuit board. However, wave soldering is not always suitable for surface mount ICs, or for printed-circuit boards with high population densities. In these situations, reflow soldering is often used.

### Through-hole mount packages

#### SOLDERING BY DIPPING OR BY SOLDER WAVE

The maximum permissible temperature of the solder is 260°C; solder at this temperature must not be in contact with the joints for more than 5 seconds. The total contact time of successive solder waves must not exceed 5 seconds.

The device may be mounted up to the seating plane, but the temperature of the plastic body must not exceed the specified maximum storage temperature ( $T_{stg(max)}$ ). If the printed-circuit board has been pre-heated, forced cooling may be necessary immediately after soldering to keep the temperature within the permissible limit.

#### MANUAL SOLDERING

Apply the soldering iron (24 V or less) to the lead(s) of the package, either below the seating plane or not more than 2 mm above it. If the temperature of the soldering iron bit is less than 300°C, it may remain in contact for up to 10 seconds. If the bit temperature is between 300 and 400°C, contact may be made for up to 5 seconds.

### Surface mount packages

#### REFLOW SOLDERING

Reflow soldering requires solder paste (a suspension of fine solder particles, flux and binding agent) to be applied to the printed-circuit board by screen printing, stencilling or pressure-syringe dispensing before package placement.

Several methods exist for reflowing; for example, infrared/convection heating in a conveyor-type oven. Throughput times (preheating, soldering and cooling) vary between 100 and 200 seconds, depending on heating method.

Typical reflow peak temperatures range from 215 to 250°C. The top-surface temperature of the packages should preferably be kept below 230°C.

#### WAVE SOLDERING

Conventional single-wave soldering is not recommended for surface mount devices (SMDs) or printed-circuit boards with a high component density, as solder bridging and non-wetting can present major problems.

To overcome these problems, the double-wave soldering method was specifically developed.

If wave soldering is used, the following conditions must be observed for optimal results:

- Use a double-wave soldering method comprising a turbulent wave with high upward pressure followed by a smooth laminar wave.
- For packages with leads on two sides and a pitch (e):
  - larger than or equal to 1.27 mm, the footprint longitudinal axis is **preferred** to be parallel to the transport direction of the printed-circuit board;
  - smaller than 1.27 mm, the footprint longitudinal axis **must** be parallel to the transport direction of the printed-circuit board.

The footprint must incorporate solder thieves at the downstream end.

- For packages with leads on four sides, the footprint must be placed at a 45° angle to the transport direction of the printed-circuit board. The footprint must incorporate solder thieves downstream and at the side corners.

During placement, and before soldering, the package must be fixed with a droplet of adhesive. The adhesive can be applied by screen printing, pin transfer or syringe dispensing. The package can be soldered after the adhesive has cured.

Typical dwell time is 4 seconds at 250°C. A mildly-activated flux will eliminate the need for removal of corrosive residues in most applications.

#### MANUAL SOLDERING

Fix the component by first soldering two diagonally-opposite end leads. Use a low-voltage (24 V or less) soldering iron applied to the flat part of the lead. Contact time must be limited to 10 seconds at up to 300°C.

When using a dedicated tool, all other leads can be soldered in one operation within 2 to 5 seconds between 270 and 320°C.

## USB device with serial interface

## PDIUSB11

**SUITABILITY OF IC PACKAGES FOR WAVE, REFLOW AND DIPPING SOLDERING METHODS**

Mounting	Package	Soldering Method		
		Wave	Reflow <sup>1</sup>	Dipping
Through-hole mount	DBS, DIP, HDIP, SDIP, SIL	suitable <sup>2</sup>	–	suitable
Surface mount	BGA, SQFP,	not suitable	suitable	–
	HLQFP, HSQFP, HSOP, SMS	not suitable <sup>3</sup>	suitable	–
	PLCC, SO, SOJ	suitable	suitable	–
	LQFP, QFP, TQFP	not recommended <sup>4, 5</sup>	suitable	–
	SSOP, TSSOP, VSO	not recommended <sup>6</sup>	suitable	–

**NOTES:**

1. All surface mount (SMD) packages are moisture sensitive. Depending upon the moisture content, the maximum temperature (with respect to time) and body size of the package, there is a risk that internal or external package cracks may occur due to vaporization of the moisture in them (the so-called "popcorn" effect). For details, refer to the Drypack information in the *"Data Handbook IC26; Integrated Circuit Packages; Section: Packing Methods"*.
2. For SDIP packages, the longitudinal axis must be parallel to the transport direction of the printed-circuit board.
3. These packages are not suitable for wave soldering as a solder joint between the printed-circuit board and heatsink (at bottom version) cannot be achieved, and as solder may stick to the heatsink (on top version).
4. If wave soldering is considered, then the package must be placed at a 45° angle to the solder wave direction. The package footprint must incorporate solder thieves downstream and at the side corners.
5. Wave soldering is only suitable for LQFP, QFP, and TQFP packages with a pitch (e) equal to or larger than 0.8 mm; it is definitely not suitable for packages with a pitch (e) equal to or smaller than 0.65 mm.
6. Wave soldering is only suitable for SSOP and TSSOP packages with a pitch (e) equal to or larger than 0.65 mm; it is definitely not suitable for packages with a pitch (e) equal to or smaller than 0.5 mm.

---

USB device with serial interface

PDIUSBD11

---

**NOTES**

## USB device with serial interface

## PDIUSB11

## Data sheet status

Data sheet status	Product status	Definition [1]
Objective specification	Development	This data sheet contains the design target or goal specifications for product development. Specification may change in any manner without notice.
Preliminary specification	Qualification	This data sheet contains preliminary data, and supplementary data will be published at a later date. Philips Semiconductors reserves the right to make changes at any time without notice in order to improve design and supply the best possible product.
Product specification	Production	This data sheet contains final specifications. Philips Semiconductors reserves the right to make changes at any time without notice in order to improve design and supply the best possible product.

[1] Please consult the most recently issued datasheet before initiating or completing a design.

## Definitions

**Short-form specification** — The data in a short-form specification is extracted from a full data sheet with the same type number and title. For detailed information see the relevant data sheet or data handbook.

**Limiting values definition** — Limiting values given are in accordance with the Absolute Maximum Rating System (IEC 134). Stress above one or more of the limiting values may cause permanent damage to the device. These are stress ratings only and operation of the device at these or at any other conditions above those given in the Characteristics sections of the specification is not implied. Exposure to limiting values for extended periods may affect device reliability.

**Application information** — Applications that are described herein for any of these products are for illustrative purposes only. Philips Semiconductors make no representation or warranty that such applications will be suitable for the specified use without further testing or modification.

## Disclaimers

**Life support** — These products are not designed for use in life support appliances, devices or systems where malfunction of these products can reasonably be expected to result in personal injury. Philips Semiconductors customers using or selling these products for use in such applications do so at their own risk and agree to fully indemnify Philips Semiconductors for any damages resulting from such application.

**Right to make changes** — Philips Semiconductors reserves the right to make changes, without notice, in the products, including circuits, standard cells, and/or software, described or contained herein in order to improve design and/or performance. Philips Semiconductors assumes no responsibility or liability for the use of any of these products, conveys no license or title under any patent, copyright, or mask work right to these products, and makes no representations or warranties that these products are free from patent, copyright, or mask work right infringement, unless otherwise specified.

Philips Semiconductors  
811 East Arques Avenue  
P.O. Box 3409  
Sunnyvale, California 94088-3409  
Telephone 800-234-7381

© Copyright Philips Electronics North America Corporation 1998  
All rights reserved. Printed in U.S.A.

Date of release: 07-99

Document order number:

9397-750-06219

*Let's make things better.*