

## FEATURES

### ■ Ultra low power

- Designed for applications that require long battery life while using standard AA/AAA batteries
- Average 20 mA in normal operation (everything on)
- Average 5 mA in idle mode (clock to the CPU stopped, everything else running)
- Average 3  $\mu$ A in standby mode (realtime clock on and everything else stopped)

### ■ Performance matching 33-MHz Intel® '486-based PC

- 15 Vax™-MIPS (Dhrystone®) at 18 MHz

### ■ ARM710A microprocessor

- ARM7 CPU
- 8 Kbytes of four-way set-associative cache
- MMU with 64-entry TLB (transition look-aside buffer)
- Little endian

### ■ DRAM controller

- Connects up to four banks of DRAM, with each bank being 32 bits wide and up to 256 Mbytes in size

(cont.)

## Low-Power System-on-a-Chip

## OVERVIEW

The CL-PS7110 is designed for ultra-low-power applications such as organizers/PDAs, two-way pagers, smart phones, and hand-held internet browsers. The device's core-logic functionality is built around an ARM710A microprocessor with 8 Kbytes of four-way set-associative unified cache.

At 18.432 MHz (for 3-V operation), the CL-PS7110 delivers nearly 15 Vax-MIPS of performance (based on Dhrystone® benchmark) — roughly the same

(cont.)

## Functional Block Diagram

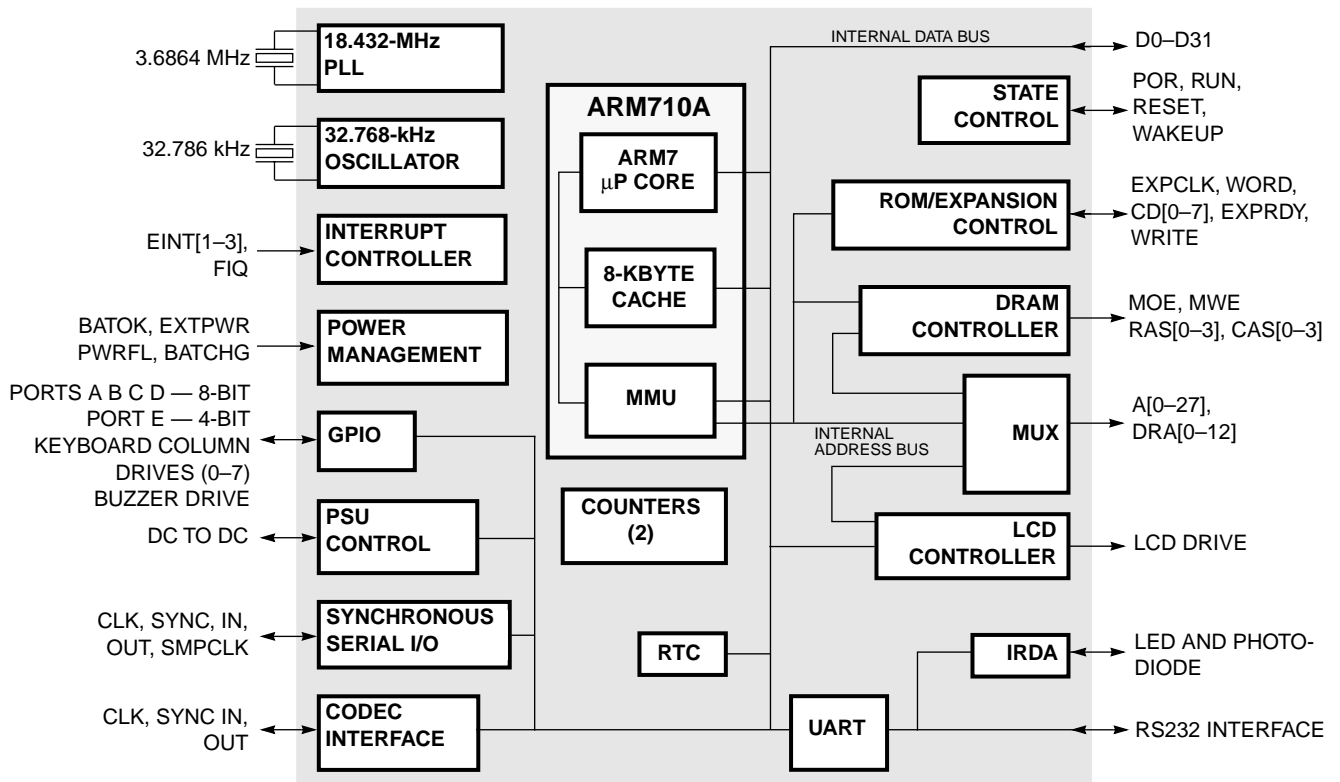

## FEATURES (cont.)

### ■ ROM/SRAM/flash memory control

- Decodes eight separate memory segments of 256 Mbytes
- Each segment can be configured as 8, 16, or 32 bits wide and support page-mode access
- Programmable access time for conventional SRAM/ROM/flash memory
- Expansion device can also be a PC Card (PCMCIA) controller

### ■ Codec interface

- Provides all necessary clocks and timing pulses and performs serialization of the data stream (or vice versa) to or from standard telephony codecs
- Data transfer at 64 kbps

### ■ Synchronous serial interface

- Supports SPI<sup>®1</sup> or Microwire<sup>®2</sup>-compatible interface

### ■ 36-bit general-purpose I/O

- Four 8-bit and one 4-bit GPIO port
- Supports scanning keyboard matrix

### ■ 16C550-style UART

- Supports bit rates up to 115.2 kbps
- Contains two 16-byte FIFOs for Tx and Rx
- Supports modem control signals

### ■ SIR (slow (9600–115.2 kbps) infrared) encoder

- IrDA (Infrared Data Association) SIR protocol encoder can be optionally switched into Tx and Rx signals of the UART up to 115 kbps

### ■ DC-to-DC converter interface

- Provides two 96-kHz clock outputs, whose duty ratio are programmable (from 1-in-16 to 15-in-16)

### ■ LCD controller

- Interfaces directly to a single-scan panel monochrome LCD
- Panel size is programmable and is any width (line length) from 16 to 1024 pixels in 16-pixel increments
- Video frame size programmable up to 128 Kbytes
- Bits per pixel programmable from 1, 2, or 4
- Two 32-bit palette registers to support 4-, 2-, or 1-bit pixel values for mapping to any of the 16 grayscale values

### ■ Two timer counters

### ■ Realtime clock (32-bit)

<sup>1</sup> SPI is a registered trademark of Motorola<sup>®</sup>.

<sup>2</sup> Microwire is a registered trademark of National Semiconductor<sup>®</sup>.

## OVERVIEW (cont.)

level of performance offered by a 33-MHz Intel<sup>®</sup> '486-based PC.

As shown in the system block diagram, simply adding desired memory and peripherals to the highly integrated CL-PS7110 completes a hand-held organizer/PDA system board. All the interface logic is integrated on-chip.

The CL-PS7110 is packaged in a 208-pin VQFP package, with a body size of 28-mm square, lead pitch of 0.5 mm, and thickness of 1.4 mm.

### Memory Interface

There are two main external memory interfaces and a DMA controller that fetches video display data for the LCD controller from main DRAM memory.

The SRAM/ROM-style interface has programmable wait state timings and includes burst-mode capability, with eight chip selects decoding eight 256-Mbyte sections of addressable space. For maximum flexibility, each bank can be specified to be 8, 16 or 32 bits wide to enable the use of low-cost memory in a 32-bit

system. The system can have an 8-bit-wide boot option to optimize memory size.

The DRAM interface allows direct connection of up to 4 banks of DRAM, each bank containing up to 256 Mbytes. To assure the lowest possible power consumption, the CL-PS7110 supports self-refresh DRAMs, which are placed a low-power state by the device when it enters its low-power standby mode.

### Serial Interface

For RS232 serial communications, the CL-PS7110 includes a UART with two 16-byte FIFOs for receive and transmit data. The UART supports bit rates of up to 115.2 kbps. An IrDA SIR protocol encoder/decoder can be optionally switched into the Rx/Tx signals to/from the UART to enable these signals to drive an infrared communication interface directly.

A full-duplex codec interface allows direct connection of a standard codec chip to the CL-PS7110, allowing storage and playback of sound.

## A CL-PS7110-Based System

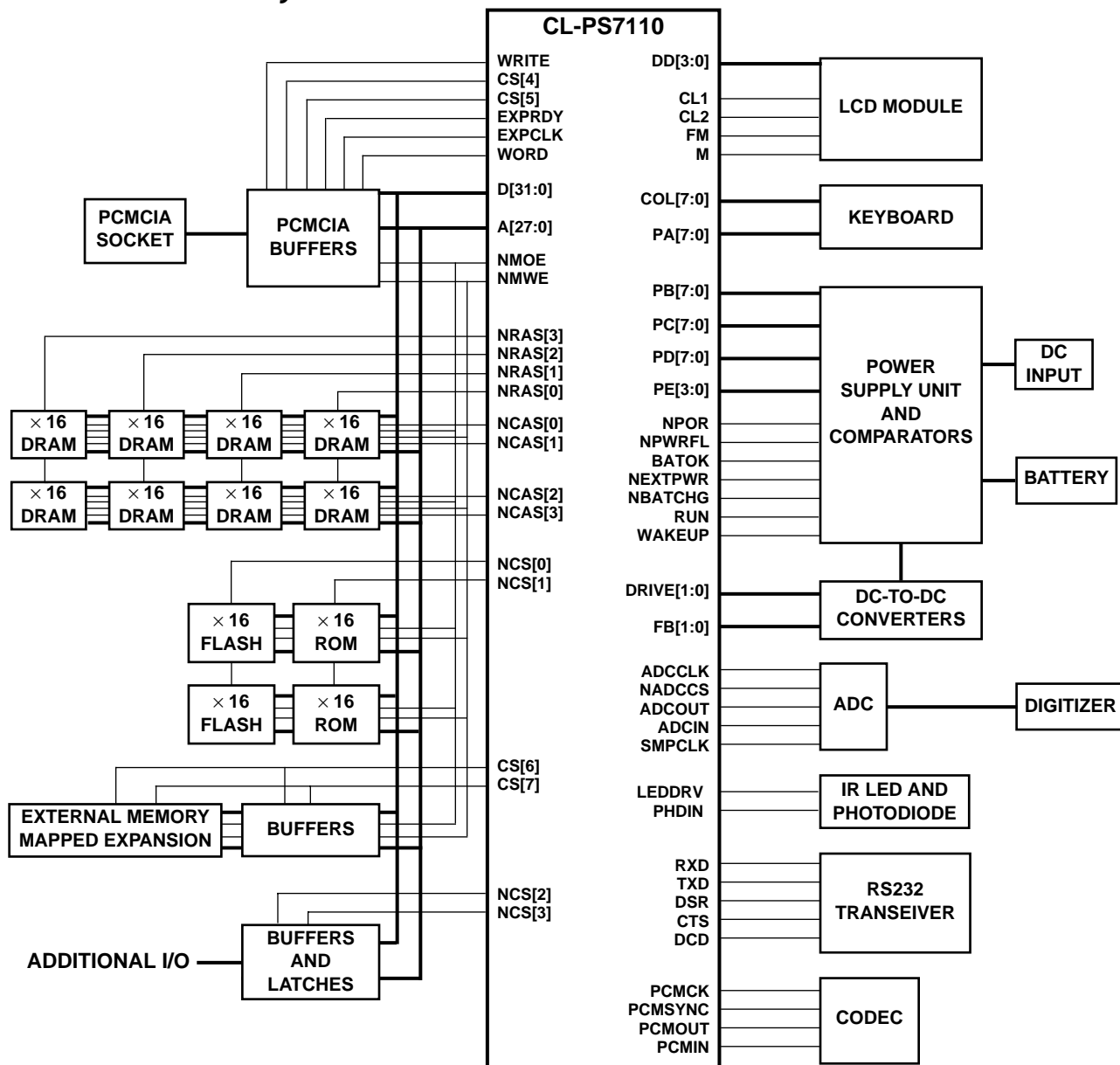

A separate synchronous serial interface supports two industry-standard protocols (SPI<sup>®</sup> and Microwire<sup>®</sup>) for interfacing to standard devices such as an ADC, allowing for peripheral expansion such as the use of a digitizer pen.

### Power Management

The CL-PS7110 is designed for low-power operation. There are three basic power states:

- **Standby** — This state is equivalent to the computer being switched off (no display), and the main oscillator is shut down. Only the realtime clock is running.
- **Idle** — In this state, the device is functioning and all oscillators are running, but the processor clock is halted while waiting for an event such as a key press.
- **Operating** — This state is the same as the idle state, except that the processor clock is running.

## TABLE OF CONTENTS

<b>LIST OF TABLES .....</b>	<b>7</b>
<b>LIST OF FIGURES.....</b>	<b>8</b>
<b>CONVENTIONS .....</b>	<b>9</b>
<b>1. FUNCTIONAL DESCRIPTION .....</b>	<b>11</b>
1.1 Overview .....	11
1.2 General .....	12
1.2.1 Clocking .....	13
1.2.2 CPU Core .....	13
1.2.3 Interrupt Controller.....	13
1.2.4 Memory Interface and DMA.....	14
1.2.5 Expansion and Memory Controller for SRAM/ROM/Flash Interface.....	17
1.2.6 DRAM Controller .....	19
1.2.7 PCMCIA Support.....	19
1.2.8 Codec Interface .....	21
1.2.9 Synchronous Serial Interface .....	21
1.2.10 LCD Controller.....	21
1.2.11 Internal UART and SIR Encoder.....	22
1.2.12 Timer Counters.....	23
1.2.13 Realtime Clock .....	23
1.2.14 DC-to-DC Converter .....	23
1.2.15 Keyboard Control.....	26
1.2.16 GPIO.....	26
1.2.17 Buzzer Control.....	26
1.2.18 Battery Management .....	27
1.2.19 State Control.....	27
1.2.20 Power Management.....	28
1.2.21 Software Model for Power Management.....	29
1.2.22 Resets .....	29
<b>2. PIN INFORMATION .....</b>	<b>31</b>
2.1 Pin Diagram .....	31
2.2 Pin Description Conventions.....	32
2.3 Pin Descriptions.....	32
2.4 Pin Descriptions.....	35
<b>3. PROGRAMMING INTERFACE.....</b>	<b>39</b>
3.1 Memory Map.....	39
3.2 Internal Registers.....	40
3.2.1 PADR — Port A Data Register .....	41
3.2.2 PBDR — Port B Data Register .....	41
3.2.3 PCDR — Port C Data Register.....	42
3.2.4 PDDR — Port D Data Register.....	42
3.2.5 PADDR — Port A Data Direction Register.....	42
3.2.6 PBDDR — Port B Data Direction Register .....	42
3.2.7 PCDDR — Port C Data Direction Register.....	42
3.2.8 PDDDR — Port D Data Direction Register.....	42

3.2.9	PEDR — Port E Data Register .....	42
3.2.10	PEDDR — Port E Data Direction Register .....	42
3.2.11	SYSCON — System Control Register .....	43
3.2.12	SYSFLG — System Status Flags Register .....	45
3.2.13	MEMCFG1 — Memory Configuration Register 1 .....	47
3.2.14	MEMCFG2 — Memory Configuration Register 2 .....	47
3.2.15	DRFPR — DRAM Refresh Period Register .....	49
3.2.16	INTSR — Interrupt Status Register .....	50
3.2.17	INTMR — Interrupt Mask Register .....	52
3.2.18	LCDCON — LCD Control Register .....	52
3.2.19	TC1D — Timer Counter 1 Data Register .....	53
3.2.20	TC2D — Timer Counter 2 Data Register .....	53
3.2.21	RTCDR — Realtime Clock Data Register .....	53
3.2.22	RTCMR — Realtime Clock Match Register .....	53
3.2.23	PMPCON — Pump Control Register .....	54
3.2.24	CODR — Codec Interface Data Register .....	54
3.2.25	UARTDR — UART Data Register .....	55
3.2.26	UBRLCR — UART Bit Rate and Line Control Register .....	55
3.2.27	PALLSW Least-Significant Word-LCD Palette Register .....	56
3.2.28	PALMSW Most-Significant Word-LCD Palette Register .....	57
3.2.29	SYNCIO Synchronous Serial Interface Data Register .....	58
3.2.30	STFCLR — Clear All Start Up Reason Flags Location .....	58
3.2.31	BLEOI — Battery Low End of Interrupt .....	58
3.2.32	MCEOI — Media Changed End of Interrupt .....	59
3.2.33	TEOI — Tick End of Interrupt Location .....	59
3.2.34	TC1EOI TC1 — End of Interrupt Location .....	59
3.2.35	TC2EOI TC2 — End Of Interrupt Location .....	59
3.2.36	RTCEOI — RTC Match End Of Interrupt .....	59
3.2.37	UMSEOI — UART Modem Status Changed End of Interrupt .....	59
3.2.38	COEOI — Codec End of Interrupt Location .....	59
3.2.39	HALT — Enter Idle State Location .....	59
3.2.40	STDBY — Enter Standby State Location .....	59
<b>4.</b>	<b>ELECTRICAL SPECIFICATIONS .....</b>	<b>60</b>
4.1	Absolute Maximum Ratings .....	60
4.2	Recommended Operating Conditions .....	60
4.3	DC Characteristics .....	61
4.4	AC Characteristics .....	62
4.5	I/O Buffer Characteristics .....	70
4.6	Test Modes .....	70
4.6.1	Oscillator and PLL Bypass Mode .....	71
4.6.2	Functional (EPB) Test Mode .....	71
4.6.3	Oscillator and PLL Test Mode .....	71
4.6.4	Pin Test Mode .....	72
4.6.5	High-Z (System) Test Mode .....	73
4.6.6	Test ROM Mode .....	73
4.6.7	Software-Selectable Test Functionality .....	74
<b>5.</b>	<b>PACKAGE SPECIFICATIONS .....</b>	<b>75</b>
5.1	208-Pin VQFP Package Outline Drawing .....	75

6.	ORDERING INFORMATION .....	76
	BIT INDEX.....	77
	INDEX.....	79

## LIST OF TABLES

Table 1-1.	Interrupt Allocation .....	14
Table 1-2.	Physical-to-DRAM Address Mapping .....	19
Table 1-3.	DRAM Address Mapping .....	20
Table 2-1.	External Signal Functions .....	32
Table 2-2.	Numeric Pin Listing .....	35
Table 3-1.	Memory Map .....	39
Table 3-2.	Internal I/O Memory Locations .....	40
Table 3-3.	Bits in SYSCON .....	43
Table 3-4.	Keyboard Scan Field .....	43
Table 3-5.	ADCCLK Frequencies .....	45
Table 3-6.	Bits in the System Status Flags Register .....	45
Table 3-7.	Values of the Bus Width Field .....	48
Table 3-8.	PCMCIA Mode Bus Width .....	48
Table 3-9.	Values of the Random Access Wait State Field .....	49
Table 3-10.	Values of the Sequential Access Wait State Field .....	49
Table 3-11.	Sense of DC-to-DC Converter Control Lines .....	54
Table 3-12.	Internal UART Bit Rates .....	56
Table 3-13.	UART Word Length .....	56
Table 3-14.	Least-Significant Word Palette Assignments .....	57
Table 3-15.	Most-Significant Word Palette Assignments .....	57
Table 3-16.	Grayscale Value to Color Mapping .....	57
Table 3-17.	Bits in SYNCIO Write Register .....	58
Table 4-1.	DC Characteristics .....	61
Table 4-2.	AC Characteristics .....	62
Table 4-3.	I/O Buffer Output Characteristics .....	70
Table 4-4.	CL-PS7110 Hardware Test Modes .....	70
Table 4-5.	EPB Test Mode Signal Assignment .....	71
Table 4-6.	Oscillator and PLL Test Mode Signals .....	72
Table 4-7.	Chip Select Address Ranges During Test ROM Mode .....	73
Table 4-8.	Expansion and ROM Interface Bus Width During Test ROM Mode .....	73

## LIST OF FIGURES

Figure 1-1.	Functional Block Diagram .....	11
Figure 1-2.	Word Write to 16-bit SRAM.....	16
Figure 1-3.	Word Write to 8-bit SRAM.....	17
Figure 1-4.	Memory Segment Usage .....	18
Figure 1-5.	Video Buffer Mapping .....	22
Figure 1-6.	Sample Schematic for Positive $V_{EE}$ Control Circuitry .....	25
Figure 1-7.	Sample Schematic for Negative $V_{EE}$ Control Circuitry.....	26
Figure 1-8.	State Diagram .....	28
Figure 4-1.	Expansion and ROM Read Timing.....	63
Figure 4-2.	Expansion and ROM Write Timing.....	64
Figure 4-3.	DRAM Read Cycles.....	65
Figure 4-4.	DRAM Write Cycles .....	66
Figure 4-5.	Video Quad Word Read .....	67
Figure 4-6.	DRAM CAS-Before-RAS Refresh Cycle .....	68
Figure 4-7.	LCD Controller Timing .....	69



## CONVENTIONS

This following section presents conventions used in this data book.

### **Abbreviations and Acronyms**

The following table lists abbreviations and acronyms used in this data book.

<b>Acronym or Abbreviation</b>	<b>Definition</b>
AC	alternating current
ADC	analog-to-digital
codec	coder/decoder
CMOS	complementary metal-oxide semiconductor
CPU	central processing unit
DC	direct current
DMA	direct-memory access
DRAM	dynamic random-access memory
EPB	embedded peripheral bus
FCS	frame check sequence
FIFO	first in/first out
GPIO	general-purpose I/O
ICT	in circuit test
IrDA SIR	infrared data association, slow (9600–115.2 kbps) infrared
LCD	liquid-crystal display
LSB	least-significant bit
MIPS	millions of instructions per second
MMU	memory management unit
PCB	printed circuit board
PDA	personal digital assistant
PIA	peripheral interface adapter
PLL	phase locked loop
PSU	power supply unit
RAM	random-access memory
RISC	reduced-instruction-set computer
ROM	read-only memory
RTC	realtime clock
SRAM	static random-access memory
TLB	translation look-aside buffer

Acronym or Abbreviation	Definition (cont.)
UART	universal asynchronous receiver transmitter
VQFP	very-tight-pitch quad flat pack

### Measurement Abbreviations

Symbol	Units of measure
°C	degree Celsius
Hz	hertz (cycle per second)
Kbyte	kilobyte (1,024 bytes)
kHz	kilohertz
kΩ	kilohm
Mbps	megabits (1,048,576 bits) per second
Mbyte	megabyte (1,048,576 bytes)
MHz	megahertz (1,000 kilohertz)
μF	microfarad
μA	microampere
μs	microsecond (1,000 nanoseconds)
mA	milliampere
ms	millisecond (1,000 microseconds)
ns	nanosecond
V	volt
W	watt

### OTHER CONVENTIONS

Hexadecimal numbers are presented with all letters in uppercase and a lowercase *h* appended. For example, *14h* and *03CAh* are hexadecimal numbers.

Binary numbers are enclosed in single quotation marks when in text. For example, '11' is a binary number.

Numbers not indicated by an *h* or single quotation marks are decimal.

The use of 'tbd' indicates values that are 'to be determined', 'n/a' designates 'not available', and 'n/c' indicates a pin that is a 'no connect'.

# 1. FUNCTIONAL DESCRIPTION

## 1.1 Overview

The CL-PS7110 is a single-device embedded controller designed to be used in ultra-low-cost applications such as a hand-held personal organizers and hand-held internet browsers. There are other devices offered by Cirrus Logic (<http://www.cirrus.com>) such as fax/modem chipsets, IR chipsets, codecs, etc., that can be used around the CL-PS7110 to build a complete hand-held organizer. The CL-PS7110 operates at both 3 V and 5 V. However, the AC timings shown in this data book (v1.5) reflect 3-V operation.

Figure 1-1 shows a simplified functional block diagram of the CL-PS7110. All external memory and peripheral devices are connected to the 32-bit data bus, using the external 28-bit address bus and control signals. Bus transfer times can be extended using the EXPRDY signal to lengthen bus cycles. The maximum burst transfer rate of the external bus is approximately 70 Mbytes/sec.

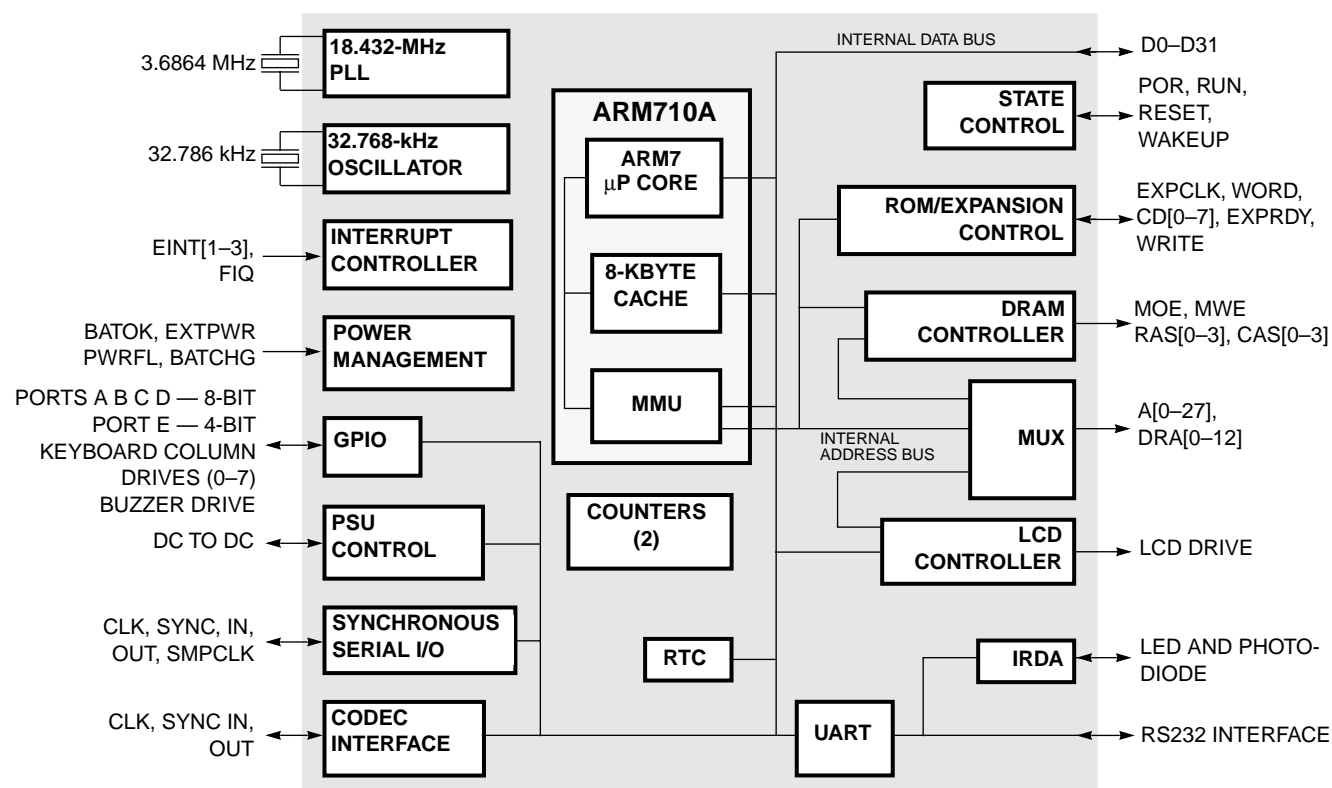

Figure 1-1. Functional Block Diagram

The core-logic functionality is built around an ARM710A microprocessor and 8 Kbytes of cache. At 18.432 MHz (for 3-V operation) and with an on-chip 8-Kbyte cache (four-way set-associative), the CL-PS7110 delivers approximately 15 MIPS of sustained performance (18.4 MIPS peak). This is approximately the same as a 33-MHz, '486-based PC.

The CL-PS7110 design is optimized for low power dissipation at 3-V operation. At 18.432-MHz clock speed, the device dissipates 66 mW during the 'operating state' (all oscillators and processor clock running), 15 mW in the 'idle state' (all oscillators running, but processor clock is halted), and 10- $\mu$ W in the 'standby state' (no display and the main oscillator is shut down). For a definition of the three states, refer to the [Section 1.2.19 on page 27](#).

The CL-PS7110 can interface to up to four banks of DRAM; each bank can be up to 256 Mbytes in size. There is also an interface for two ROMs, each up to 256 Mbytes, and six expansion devices also up to 256 Mbytes. These expansion devices could be additional ROM or a PC Card controller. The CL-PS7110 has a built-in, high-speed (115 kbps) UART with Rx and Tx FIFOs, and also supports the IrDA SIR protocol.

The CL-PS7110 is fabricated with a 0.6- $\mu$ m CMOS process and is fully static. The CL-PS7110 is a 208-pin VQFP with a body size of 28-mm square, a lead pitch of 0.5 mm, and a maximum thickness of 1.5 mm.

## 1.2 General

The CL-PS7110 is built around the ARM710A processor core. For a more detailed description of the ARM710A, refer to the *ARM710A Data Sheet* (<http://www.arm.com/>). The principle functional blocks in CL-PS7110 are:

- ARM710A CPU core
- Memory management unit from the ARM700 and ARM710 processors
- 8 Kbytes of unified instruction and data cache, plus a four-way set-associative cache controller
- Interrupt and fast interrupt controller
- Expansion and ROM interface giving 8  $\times$  256-Mbyte expansion segments with independent wait state control
- DRAM controller supporting Fast Page mode and self-refresh in Standby mode
- 36 bits of general-purpose peripheral I/O
- Telephony codec interface and 16-byte FIFO
- Programmable, 4-bits-per-pixel LCD controller, mapping the video buffer into the main DRAM
- Full-duplex UART and two 16-byte FIFOs, plus logic to implement the IrDA SIR protocol, capable of speeds up to 115 kbps
- Two 16-bit general-purpose counter timers
- A 32-bit realtime clock and comparator
- DC-to-DC converter interface
- System state control and power management
- Synchronous serial interface for Microwire<sup>®</sup> or SPI<sup>®</sup> peripherals (such as ADCs)
- Pin test and device-isolation logic
- External tracing support for debug
- Main oscillator and PLL (phase locked loop) to generate the system clock of 18.432 MHz from a 3.6864-MHz crystal
- A low-power 32.768-kHz oscillator

### **1.2.1 Clocking**

The main bus clock runs at 18.432 MHz and is derived from the output of the 3.6864-MHz oscillator, using an on-chip PLL to multiply by 10 and then divide by 2 to ensure a proper 50–50 mark space ratio is achieved. The main bus clock is routed only to the ARM710A, the LCD controller, the memory controller peripherals, and the baud-rate generator. Clocks required for the other peripherals are lower frequency, and are generally not required to be synchronous to the main bus clock. These clocks are centrally generated using ripple count stages where possible to minimize power consumption, and distributed to the appropriate peripherals.

### **1.2.2 CPU Core**

The ARM710A microprocessor is a 32-bit RISC processor directly connected to the 8-Kbyte unified cache. This cache has 512 lines of four words arranged as a four-way set-associative cache. The cache is directly connected to the ARM710A microprocessor and caches the *virtual address* from the processor. The MMU translates the virtual address into a physical address, it contains a 64-entry TLB (translation look aside buffer) and is *post cache*, that is, it only translates external memory references (cache misses) to save power.

Refer to descriptions of the Interrupt Status register (INTSR) and Internal Mask register (INTMR) in the *ARM710A Data Sheet*.

### **1.2.3 Interrupt Controller**

The ARM710A has two interrupt types: IRQ (interrupt request) and FIQ (fast interrupt request). The interrupt controller in the CL-PS7110 controls interrupts from 16 different sources. Twelve interrupt sources are mapped to the IRQ input and four sources are mapped to the FIQ input. FIQs have a higher priority than IRQs; if two interrupts within the same group (IRQ or FIQ) are active, software must resolve the order in which they are serviced.

All interrupts are *level-sensitive*, that is, they must conform to the following sequence.

- 1) The device asserts the appropriate interrupt request line.
- 2) If the appropriate bit is set in the Interrupt Mask register, either FIQ or IRQ is asserted by the interrupt controller.
- 3) If interrupts are enabled, the processor jumps to the appropriate vector.
- 4) Interrupt dispatch software reads the Interrupt Status register to establish the source(s) of the interrupt, then calls the appropriate interrupt service routine(s).
- 5) Software in the interrupt service routine clears the interrupt source by some action specific to the device requesting the interrupt (for example, reading the UART Rx register).
- 6) The interrupt service routine can then re-enable interrupts, any other pending interrupts are serviced in a similar way or returned to the interrupt dispatch code, which checks for any more pending interrupts and dispatches them accordingly.

**Table 1-1. Interrupt Allocation**

Interrupt	Bit in Mask and ISR	Name	Comment
FIQ	0	EXTFIQ	External fast interrupt input (NEXTFIQ pin).
FIQ	1	BLINT	Battery low interrupt.
FIQ	2	WEINT	Watch dog expired interrupt.
FIQ	3	MCINT	Media changed interrupt.
IRQ	4	CSINT	Codec sound interrupt.
IRQ	5	EINT1	External interrupt input 1 (NEINT1 pin).
IRQ	6	EINT2	External interrupt input 2 (NEINT2 pin).
IRQ	7	EINT3	External interrupt input 3 (EINT3 pin).
IRQ	8	TC1OI	TC1 under flow interrupt.
IRQ	9	TC2OI	TC2 under flow interrupt.
IRQ	10	RTCMI	RTC compare match interrupt.
IRQ	11	TINT	64-Hz tick interrupt.
IRQ	12	UTXINT	Internal UART transmit FIFO empty interrupt.
IRQ	13	URXINT	Internal UART receive FIFO full interrupt.
IRQ	14	UMSINT	Internal UART modem status changed interrupt.
IRQ	15	SSEOTI	Synchronous serial interface end of transfer interrupt.

### 1.2.4 Memory Interface and DMA

The CL-PS7110 memory controller is designed for maximum flexibility. Requests for external memory accesses from the ARM710A are decoded and the appropriate external memory access or internal bus cycle is initiated accordingly.

There are two main external memory interfaces:

- DRAM controller
- Expansion memory controller for SRAM/FLASH/ROM

The CL-PS7110 provides a DMA controller (see [Section 1.2.5](#)) that allows video display data for the LCD controller to be fetched directly from main DRAM memory, independent of internal CL-PS7110 activity.

Bus cycles generated by the CL-PS7110 depend on the requester and the target. The possible requesters are the ARM710A core, the DMA controller and the DRAM refresh controller. The two types of targets are DRAM banks and ROM/expansion banks. A data transfer may take multiple bus cycles. The arbitration for the bus is at the beginning of a transfer. The priority is fixed with DMA highest, then refresh, followed by the ARM710A. Once granted the bus, the maximum burst to a ROM/expansion bank is four bus cycles, regardless of the transfer width. The ARM710A core can produce byte, word, multi-word accesses. Multi-

word accesses are produced by cache line fetches and block data transfer instructions. They can be considered a burst of word reads.

### **Reads**

For byte reads, the CL-PS7110 will rotate the data if needed so that, regardless of the width of the memory bank, the addressed byte is in the correct position. The remaining bytes will be filled with zeros. Normally, word accesses to non-word aligned addresses cause an alignment fault. However, if the alignment fault check in the MMU is not enabled, a word read from an address offset from a word boundary will cause the data to be rotated into the register as if it were a byte read. Half-word aligned reads will place the data in correct bytes of the register. Two shift operations are then required to zero-fill or sign extend the data.

### **Writes**

During byte writes, the data is replicated on each of the four bytes of the data bus. For DRAM writes, there is CAS line per byte and only the CAS for the correct byte is enabled. For writes to byte-wide ROM/expansion banks, the nMWE signal is directly used as the write enable. For writable 16-bit ROM/expansion banks, two write enables must be decoded from the WORD, nMWE and address line A0 (refer to [Figure 1-2](#)). For writable 32-bit ROM/expansion banks, four write enables must be decoded from the same signals plus the A1 address line. A byte write always causes a single bus cycle. Word writes to word-aligned addresses are handled by the CL-PS7110, regardless of the width of the ROM/expansion bank. Accesses to 8- or 16-bit-wide banks will cause multiple bus cycles (refer to [Figure 1-3](#)). Word writes to non-word-aligned addresses normally cause an alignment fault. If the alignment fault check in the MMU is not enabled, non-aligned word writes act as if both low address bits were zero.

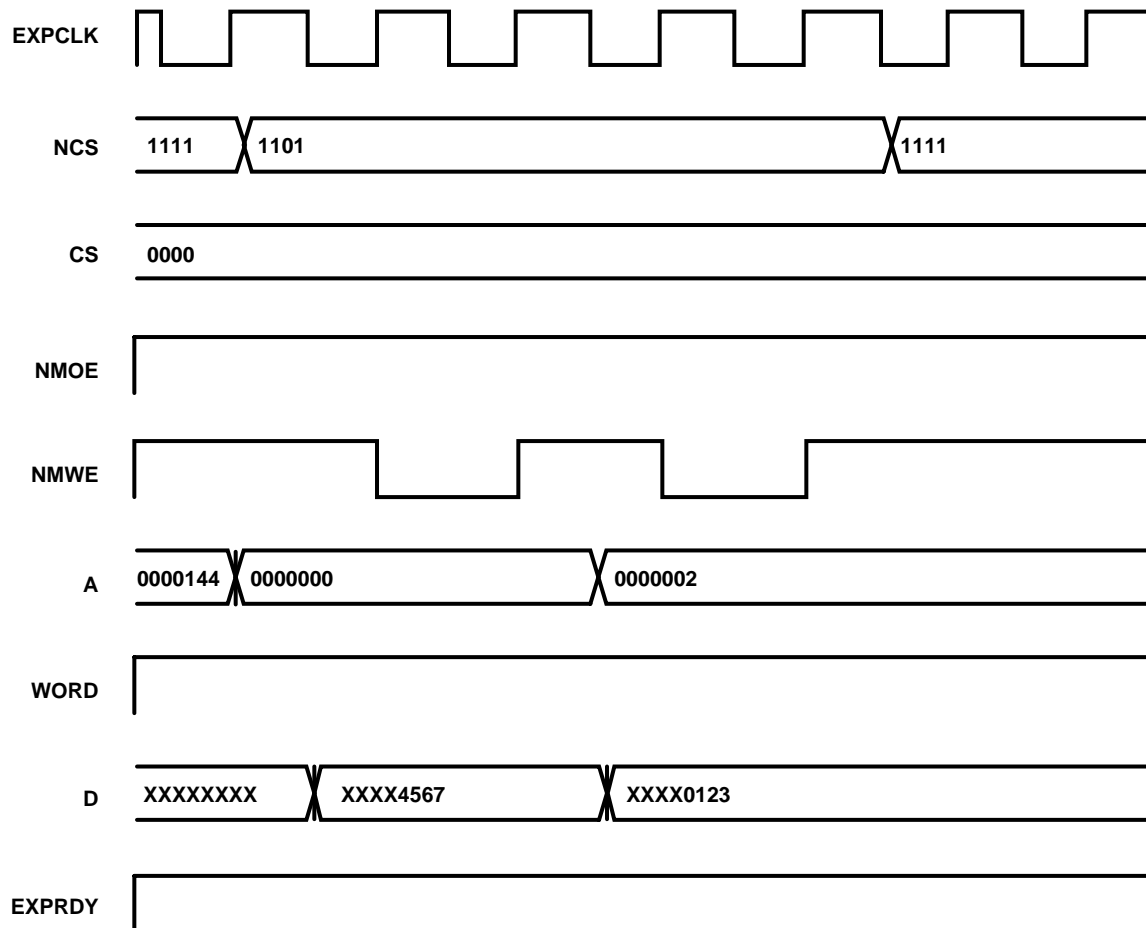

**NOTE:** A store of 0X01234567 is split into two 16-bit stores by CL-PS7110 hardware.

**Figure 1-2. Word Write to 16-bit SRAM**



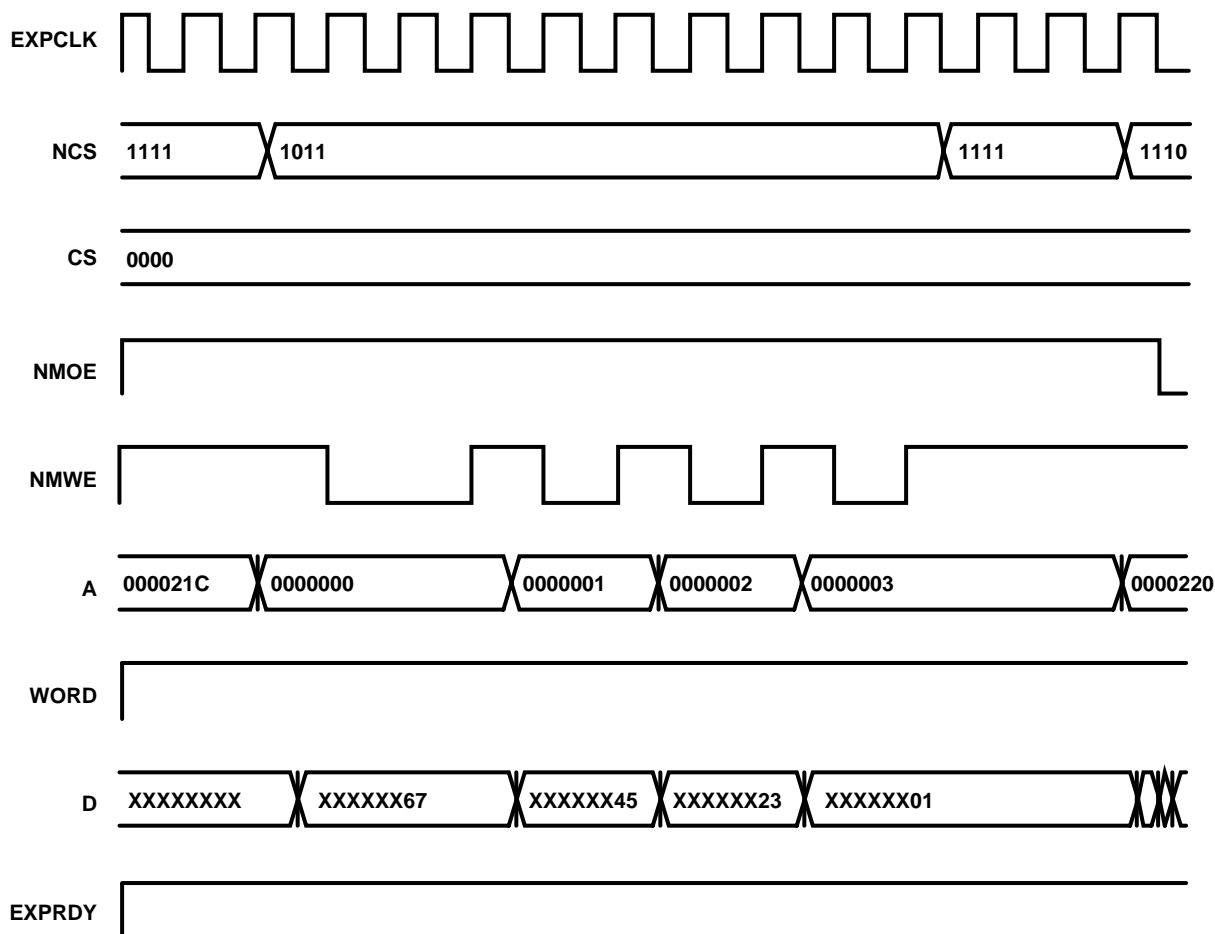

**NOTE:** A store of 0X0123456 is split into four 8-bit stores by CL-PS7110 hardware.

**Figure 1-3. Word Write to 8-bit SRAM**

### 1.2.5 Expansion and Memory Controller for SRAM/ROM/Flash Interface

Eight separate linear memory or expansion segments are decoded by the CL-PS7110. Each segment is 256 Mbytes in size and can be interfaced by using a conventional SRAM-like interface. Each segment can be individually programmed to be 8, 16, or 32 bits wide, support Page mode access, and execute from 0–4 wait states. In addition, bus cycles can be extended using the EXPRDY input signal. Two segments are allocated to ROM program segments and six to memory-mapped expansion. However, this is arbitrary and can be redefined. Page mode access is accomplished by running up to four accesses together, this can significantly improve bus bandwidth to devices, such as ROMs. Sequential Burst mode access is always faulted (the bus returned to idle) after four accesses, regardless of bus width to allow DMA and refresh cycles.

Each memory area has a single byte control register field, allowing the bus width and access timing to be programmed. Refer to the description of MEMCFG1 and MEMCFG2 registers on [page 47](#).

Figure 1-4 shows the usage of such memory segments.

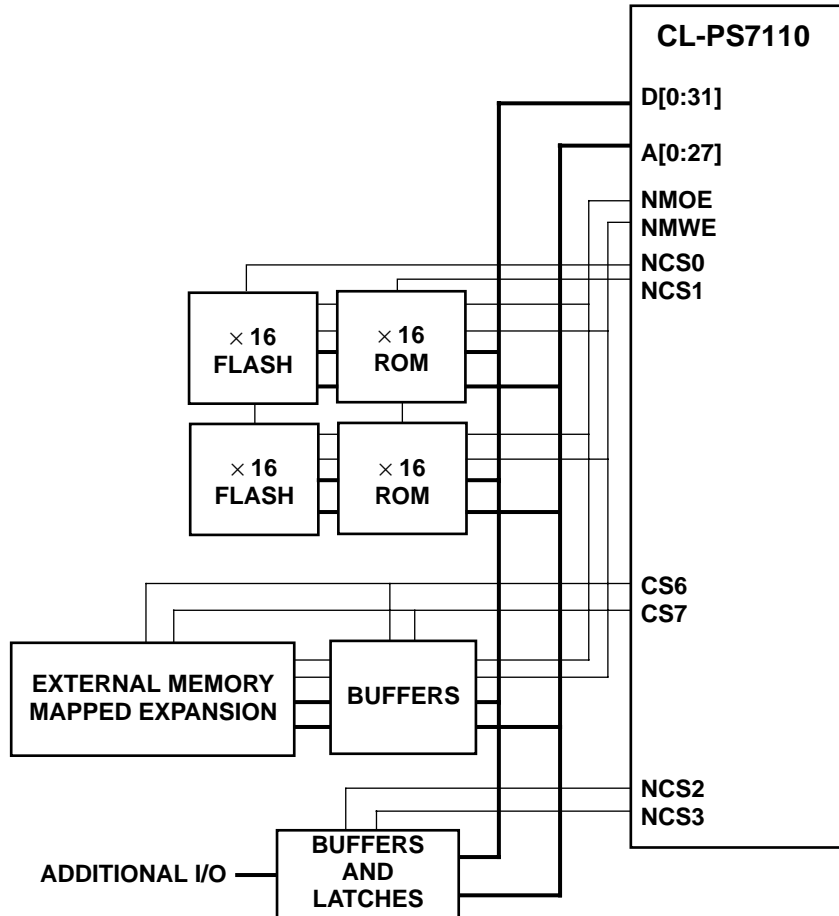

**Figure 1-4. Memory Segment Usage**

The width of each the ROM/expansion bank is set in its Memory Configuration Register 1 (see [Section 3.2.13](#)). This register is cleared to zero by a power-on reset. The CL-PS7110 boots from ROM/expansion bank 0. To allow for booting from 8- or 32-bit memory devices, the state of port E bit 0 is sampled during power-on reset and stored into the BOOT8BIT Mode register. If this bit is low, all zeros in the width field of a memory configuration register indicates a 32-bit-wide bank and all ones a 8-bit device. If this bit is high, the decoding of the bus width field is inverted, so all zeros indicates a 8-bit device. This way, a pull-up or pull-down on port E bit 0 indicates the size of the boot device. For consistency, the BOOT8BIT Mode has the same effect on all ROM/expansion banks.

The PCMCIA mode is a special case. If the width field of the Memory Configuration Register 1 is set to PCMCIA mode, the upper address bits are decoded to determine the bus width and type of access. The PCMCIA address bits A0 to A25 are driven by CL-PS7110 address bits A0 to A25. CL-PS7110 address bits A26 and A27 are decoded to specify the type and width of the access. If both are zeros, it is an access to the 8-bit-wide attribute memory. If only A26 is a one, it is an access to the 16-bit-wide common memory. If only A27 is a one, it is an access to a 8-bit-wide I/O register. If both are ones, it is an access to a 16-bit-wide I/O register.

The ARM710A core only supports byte or word accesses. Normally, word accesses are converted to multiple bus cycles that match the width of the ROM/expansion bank. Word accesses to PCMCIA 16-bit-wide

I/O registers are the exception. Reading or writing an I/O register may have side effects, so a single 16-bit access is needed. A byte access may trigger a side effect before the other byte is transferred, and a word access could affect neighboring I/O registers. To provide 16-bit-wide accesses, no bus width conversion is done for word accesses. Instead, there is a single bus cycle with only data bits D0 to D15 valid.

If alignment fault checking is enabled in the ARM710A core, all word accesses require a word-aligned address, that is both A0 and A1 must be zero. To access the 16-bit I/O registers that are not at word-aligned addresses (that is, A1 is one), the CL-PS7110 makes special use of address bit 25. For a PCMCIA bank, if address bits A25 to A27 are all ones, the A25 output pin is driven low and the A1 output pin is driven high. This restricts 16-bit accesses to the low 32 Mbytes of the PCMCIA I/O space, but allows access to all registers in this range.

### 1.2.6 DRAM Controller

The DRAM controller in the CL-PS7110 provides all connections to directly interface up to four banks of DRAM. Each bank is 32-bits wide and up to 256 Mbytes in size. Four RAS lines are provided, one per bank and four CAS lines are provided, one per byte line. As the DRAM device size is not programmable, if devices are used that are smaller than the largest size supported (1 Gbit) this leads to a segmented memory map, each bank being separated by 256 Mbytes. Segments that are smaller than the bank size repeat within the bank. [Table 1-2](#) shows the mapping of physical address to DRAM row and column address. This mapping has been organized to support any DRAM device size from 4 Mbit to 1 Gbit with a 'square' row and column configuration, that is, the number of column addresses is equal to the number of row addresses. If a non-square DRAM is used, further fragmentation of the memory map can occur; however, the smallest contiguous segment is always 1 Mbyte.

In addition to supporting standard refresh cycles, self-refresh DRAM is supported such that system DRAM can be put into a low-power state by the ARM710A before entering its low-power Standby mode.

DMA takes priority over other external memory or I/O accesses under the control of the internal bus arbiter. Requests for more data are received from the FIFO buffer at the front end of the datapath through the LCD controller. The DMA request is serviced by providing a quad word of data from the frame buffer that starts at location zero in main DRAM memory. Meanwhile the CPU continues execution, including accesses to the other peripherals. Refer to [Section 1.2.10 on page 21](#) for the description of the LCD controller.

### 1.2.7 PCMCIA Support

As mentioned in [Section 1.2.5](#) (expansion memory controller), there are eight separate linear memory segments supported and one can use one of the segments to interface with a PCMCIA card.

To design a PCMCIA-card interface to support 3/5-V cards and hot insertion, isolation buffers for address and data will be required. A sample design is provided in CL-PS7110 Evaluation kit. A PAL (22LV10) is used to decode PCMCIA card signals out of the CL-PS7110 address and control bus. The PAL equations are available in the *Evaluation Kit User's Manual*.

**Table 1-2. Physical-to-DRAM Address Mapping**

Memory Address	DRAM Column	DRAM Row	Pin Name
0	A2	A10	A27/DRA0
1	A3	A11	A26/DRA1

**Table 1-2. Physical-to-DRAM Address Mapping (cont.)**

2	A4	A12	A25/DRA2
3	A5	A13	A24/DRA3
4	A6	A14	A23/DRA4
5	A7	A15	A22/DRA5
6	A8	A16	A21/DRA6
7	A9	A17	A20/DRA7
8	A19	A18	A19/DRA8
9	A21	A20	A18/DRA9
10	A23	A22	A17/DRA10
11	A25	A24	A16/DRA11
12	A27	A26	A15/DRA12

Table 1-3 shows the address mapping for various DRAMs with square and non-square row and address inputs assuming **two**  $\times 16$  devices are connected to each RAS line. This mapping is then repeated every 256 Mbytes for each DRAM bank. *n* is given by **n = 0xC + bank number** (for example, 0xC for bank 0; 0xF for bank 3, etc.).

**Table 1-3. DRAM Address Mapping**

Device Size	Address Configuration	Total Size of Bank	Address Range of Segment(s)	Size of Segment(s)
4 Mbits	9 Row $\times$ 9 Column	1 Mbyte	n000.0000–n00F.FFFF	1 Mbyte
16 Mbits	10 Row $\times$ 10 Column	4 Mbytes	n000.0000–n03F.FFFF	4 Mbytes
16 Mbits	12 Row $\times$ 8 Column	4 Mbytes	n000.0000– n007.FFFF n010.0000–n017.FFFF n040.0000–n047.FFFF n050.0000–n057.FFFF n100.0000–n107.FFFF n110.0000–n117.FFFF n140.0000–n147.FFFF n150.0000–n157.FFFF	512 Kbytes
64 Mbits	11 Row $\times$ 11 Column	16 Mbytes	n000.0000–n0FF.FFFF	16 Mbytes
64 Mbits	13 Row $\times$ 9 Column	16 Mbytes	n000.0000–n01F.FFFF n040.0000–n05F.FFFF n100.0000–n11F.FFFF n140.0000–n15F.FFFF n400.0000–n41F.FFFF n440.0000–n45F.FFFF n500.0000–n51F.FFFF n540.0000–n55F.FFFF	2 Mbytes
256 Mbits	12 Row $\times$ 12 Column	64 Mbytes	n000.0000–n3FF.FFFF	64 Mbytes
1 Gbit	13 Row $\times$ 13 Column	256 Mbytes	n000.0000–nFFF.FFFF	256 Mbytes

The DRAM controller contains a programmable refresh counter. The refresh rate is controlled using the DRAM Refresh Period register (DRFPR).

### **1.2.8 Codec Interface**

The codec interface allows a direct connection of a telephony-type codec to the CL-PS7110. It provides all the necessary clocks and timing pulses and performs serialization of the data stream (or vice versa) to or from the codec. The interface is full-duplex and contains two separate data FIFOs.

Data is transferred to or from the codec at 64 kbps, either written to or read from the appropriate 16-byte FIFO. The sound interrupt is generated every 8 bytes transferred (FIFO half full/empty), which means the interrupt rate is reduced from 8 to 1 kHz with a latency of 1 ms.

### **1.2.9 Synchronous Serial Interface**

The synchronous serial interface allows peripheral devices, such as ADCs, that have a SPI- or Microwire-compatible interface to be directly connected to the CL-PS7110. The clock output frequency (ADCCLK) is programmable and only active during data transmissions to save power (refer to the Example 1 table on [page 24](#)). The output channel is fed by an 8-bit shift register, and the input channel is captured by a 16-bit shift register. The clock and synchronization pulses are activated by a write to the Output Shift register. During transfers the SSIBUSY (Synchronous Serial Interface Busy) bit in the System Status Flags register is set. When the transfer is complete and valid data is in the 16-bit read shift register the SSEOTI interrupt is asserted and the SSIBUSY bit is cleared. An additional sample clock (SMPCLK) can be enabled independently and is set at twice the transfer clock frequency.

### **1.2.10 LCD Controller**

The LCD controller provides all necessary control signals to directly interface to a single-scan panel multiplexed LCD. The panel size is programmable and can be any width (line length) from 16 to 1024 pixels in 16-pixel increments. The total video frame size is programmable up to 128 Kbytes. This equates to a theoretical maximum panel size of 1024 × 256 pixels in 4-bits-per-pixel mode. The LCD controller uses a 9-stage FIFO to buffer the incoming display data, which is replenished by hardware DMA under the control of the CL-PS7110 DMA controller.

The video RAM is mapped into the base of the main DRAM memory area, which is fixed at physical address 0xC000.0000. The number of bits per pixel is programmable from 1, 2, or 4.

The screen is mapped to the video buffer as one contiguous block where each horizontal line of pixels is mapped to a set of consecutive bytes or words in the video RAM. The video buffer can be accessed word-wide as pixel 0 is mapped to the LSB in the buffer, that is, the pixels are arranged in a little-endian manner.

The pixel bit rate and the LCD refresh rate can be programmed from 18.432 MHz to 576 kHz. The LCD controller is programmed by writing to the LCD Control register (LCDCON).

The LCD controller also contains two 32-bit palette registers, these allow any 4-, 2-, or 1-bit pixel value to be mapped to any of the 15 grayscale values available. Any 4-bit logical grayscale value can be mapped to any of the 16 physical grayscales. The palettes are written to directly as two 32-bit memory-mapped registers.

[Figure 1-5 on page 22](#) shows the organization of the video map for all combinations of bits per pixel.

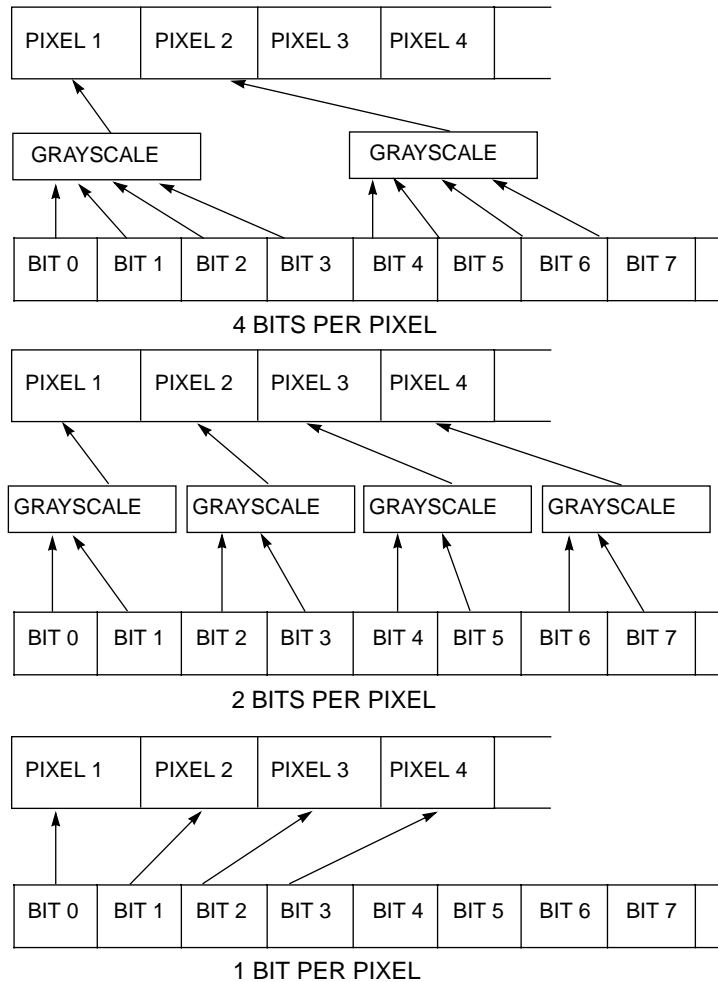

**Figure 1-5. Video Buffer Mapping**

The refresh rate is not affected by the number of bits per pixel. However, the LCD controller fetches twice the data per refresh for 4-bits-per-pixel compared to 2-bits-per-pixel. The main reason for reducing the number of bits per pixel is to reduce the power consumption of the DRAMs in bank 0 where the video buffer is mapped.

### 1.2.11 Internal UART and SIR Encoder

The CL-PS7110 contains a built-in UART, which offers similar functionality to the National Semiconductor® 16C550 device. It can support bit rates of up to 115.2 kbps and contains two 16-byte FIFOs for receive and transmit.

Only three modem-control input signals are supported: CTS, DSR, and DCD. The additional RI input modem control line is not supported. Output modem control lines (such as, RTS and DTR) are not explicitly supported, but can be implemented using bits from the general-purpose PIA ports in the CL-PS7110.

UART operation and line speed are controlled by the UART Bit Rate and Line Control (UBRLCR) register. Three interrupts can be generated by the UART: Rx, Tx, and Modem Status Changed. The Rx interrupt is asserted when the FIFO becomes half full or if the FIFO is non-empty for longer than three character length times with no more characters being received. The Tx interrupt is asserted if the FIFO buffer reaches half empty. The Modem Status Changed interrupt is generated if either of the modem status bits change state.

Framing and parity errors are detected as each byte is received and pushed onto the Rx FIFO. An overrun error generates an Rx interrupt immediately. All error bits can be read from the 11-bit-wide data register. The FIFO can also be programmed to only be 1 byte deep (such as, a conventional UART with double buffering).

The CL-PS7110 also contains an IrDA SIR protocol encoder. This encoder can be optionally switched into the Tx and Rx signals, so that these can be used to directly drive an infrared interface. If the SIR protocol encoder is enabled, the UART Tx line is held in the passive state and transitions of the Modem Status Changed or Rx lines have no effect.

### **1.2.12 Timer Counters**

The CL-PS7110 has two integrated identical timer counters, referred to as TC1 and TC2. Each timer counter has an associated 16-bit read/write data register and some control bits in the System Control register. Each counter is immediately loaded with the value written to the data register. This value is then *decremented* on the second active clock edge to arrive after the write (that is, after the first complete period of the clock). When the timer counter under-flows (reaches 0) the appropriate interrupt is asserted. The timer counters can be read at any time. The clock source and mode are selectable by writing to various bits in the System Control register (clock sources are 512 and 2 kHz).

The timer counters can operate in two modes: Free-running or Prescale.

#### **1.2.12.1 Free-Running Mode**

In Free-running mode, the counter wraps around to 0xFFFF when it under-flows and continues counting down. Any value written to TC1 or TC2 is decremented on the second edge of the selected clock.

#### **1.2.12.2 Prescale Mode**

In Prescale mode, the value written to TC1 or TC2 is automatically reloaded when the counter under-flows. Any value written to TC1 or TC2 is decremented on the second edge of the selected clock. This mode can produce a programmable frequency to drive the buzzer or generate a periodic interrupt.

### **1.2.13 Realtime Clock**

The CL-PS7110 contains a 32-bit RTC (realtime clock). The RTC can be written to and read from in the same manner as the timer counters, but is 32 bits wide. The RTC is always clocked at 1 Hz and also contains a 32-bit output-match register, which can be programmed to generate an interrupt when the time in the RTC matches a specific time written to this register.

### **1.2.14 DC-to-DC Converter**

Two programmable duty ratio 96-kHz clock outputs are provided by the CL-PS7110. These drives are to be used as DC-to-DC converters in the PSU (power-supply unit) subsystem. These clocks are enabled by external input pins that are normally connected to the output from comparators monitoring the DC-to-DC converter output. The duty ratio (and hence the converter on-time) can be programmed from 1-in-16

to 15-in-16. The sense of the DC-to-DC converter drive signal (active-high or -low) is determined by latching the state of this drive signal during power-on reset (that is, a pull-up resistor on the drive signal results in an active-low drive output and vice versa). This allows either positive or negative voltages to be generated by the DC-to-DC converter.

An example of how to use the DC-to-DC converter is shown below. The objective of Example 1 is to have constant  $V_{EE}$  for the bias generator of an LCD panel to control the contrast. Four of the GPIO pins (shown as PD4, PD5, PD6 and PD7 in [Figure 1-2](#) and [Figure 1-3](#)) are used to choose various resistor values. The Drive 1 pin is connected to the base of the biasing transistor. The  $V_{EE}$  is the maximum voltage that is required. The feedback mechanism via the FB1 pin ensures that whenever software changes the pulse width using the Pump Control register (PMPCON), the voltage level is kept at the desired level for  $V_{EE}$ .

The same technique could be used for keeping  $V_{PP}$  for flash at a constant level as shown in Example 2.

### **Example 1**

Following is a sample schematic for a positive and negative  $V_{EE}$  control circuitry. The same circuitry may be applied for the 12-V  $V_{PP}$  generator. Assume that the nominal  $V_{EE}$  voltage for a given LCD is 28 V, and the range covered is from 27 to 29 V (to assure a sufficient contrast control range).

<b>Resistor</b>	<b>Notes</b>
R75	Pull down for positive $V_{EE}$ .
R53	Pull up for LM339 open-drain output.
R54	Choose to select a voltage at the + terminal of the comparator at what point the feedback output will switch off (high), thus turning off the Drive output.
R55	To select voltage level on the + input of the comparator to application $V_{REF}$ (1.5V).
R62–65	This resistor network allows $V_{EE}$ to be programmed under program control. If all outputs are low, $V_{EE}$ is at the maximum. Turning on the outputs increases the voltage at the comparator, and therefore decreases $V_{EE}$ .

1. **Connect a load resistor over C2 to force approximately 2 mA of current (or whatever your panel's typical value is).**
2. **Program the Pump Control register to 5, set PD7..4 to high.**
3. **Set R55 such that  $V_{EE}$  is at the minimum 27 V.**
4. **Set PC7..4 to '1111';  $V_{EE}$  should exceed 29 V.**



Now the panel can be connected and the contrast fine-tuned by changing the Pump Control register value for the appropriate drive output.

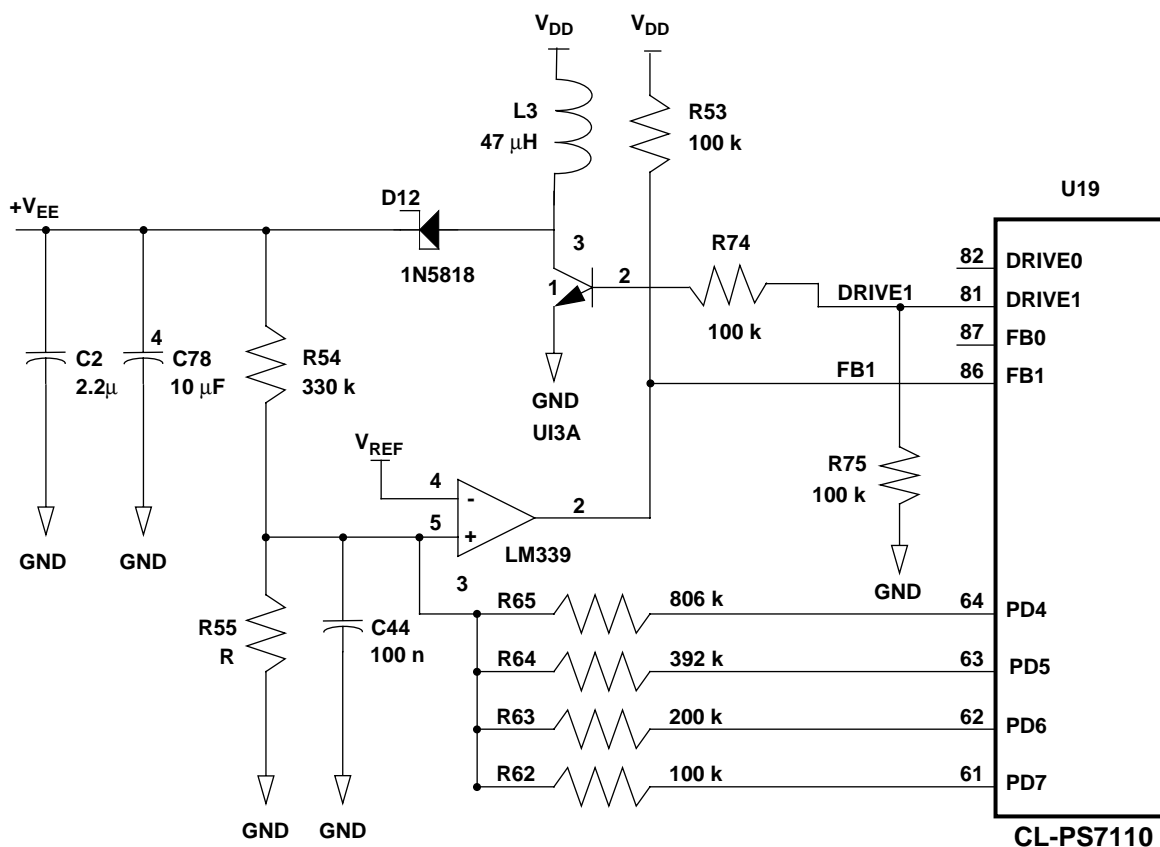
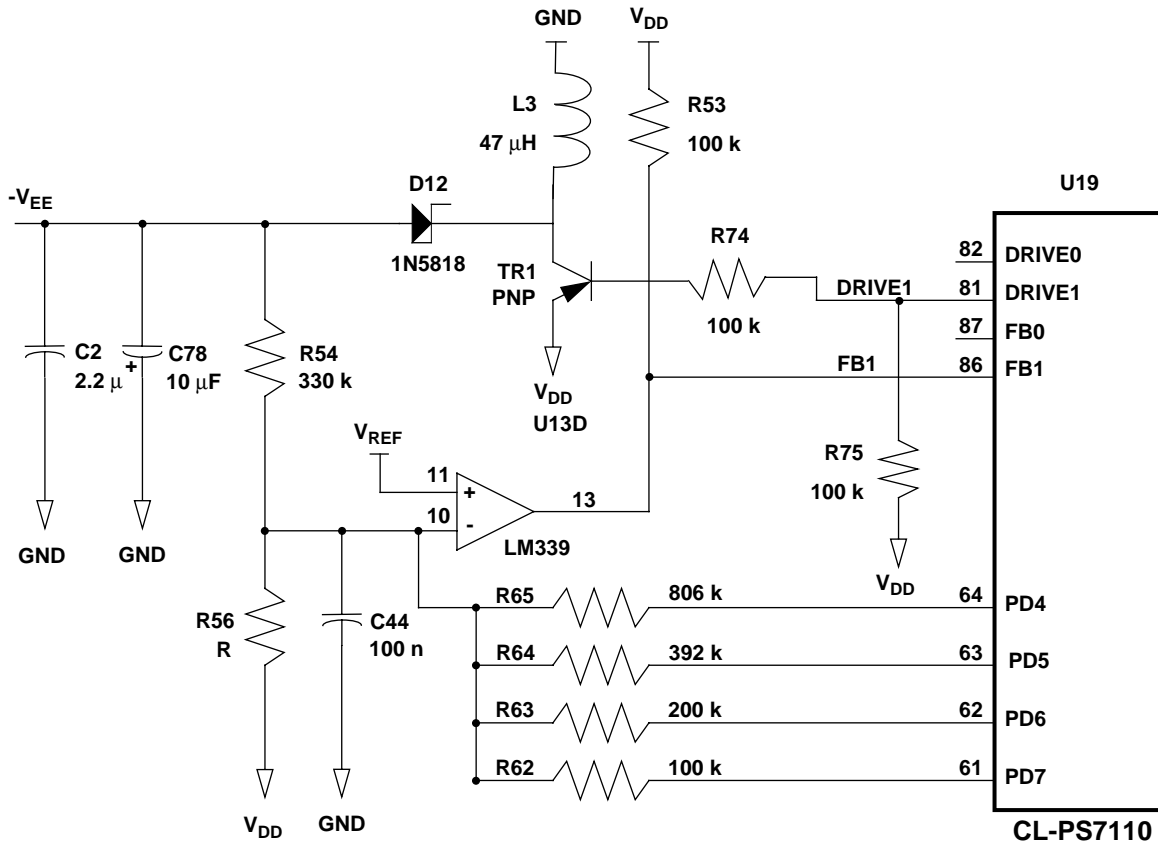

Figure 1-6. Sample Schematic for Positive  $V_{EE}$  Control Circuitry

**Example 2**

Resistor	Notes
R73	Pull down for positive $V_{EE}$ .
R53	Pull up for LM339 open-drain output.
R54	Selects a voltage at the terminal of the comparator, at which point the feedback output switches off (high), thus turning off the Drive output.
R56	Selects voltage level on input of comparator to application $V_{REF}$ (1.5 V).
R62–65	This resistor network allows $V_{EE}$ to be programmed under program control. If all outputs are low, $V_{EE}$ is at the maximum. Turning on the outputs increases the voltage at the comparator, and therefore decreases $V_{EE}$ .



**Figure 1-7. Sample Schematic for Negative  $V_{EE}$  Control Circuitry**

### 1.2.15 Keyboard Control

A keyboard can be connected using any of the serial channels. The CL-PS7110 provides a seamless interface for connecting a scanning keyboard. There are column (COL[0-7]) pins for connecting to the 8 columns of the scanning keyboard. The GPIO pins can be used for row addressing; the GPIO pins 0-8 can be configured as a single 8-bit port (PA[0-7]).

### 1.2.16 GPIO

There are 36 general-purpose pins on CL-PS7110. These pins are user-configurable as input or output. The 36 pins can be arranged as 4-byte-wide registers (which can also be read back as a single 32-bit word), and one nibble-wide port (described as Port A, Port B, Port C, Port D and Port E in the device pin diagram). Four of the I/O pins have extra-high drive output buffers to allow direct drive of an LED, for example.

### 1.2.17 Buzzer Control

There a single pin for buzzer control. When the BZMOD bit of the SYSCON register (described in [Section 3.2.11](#)) is reset, the bit BZTOG can be used to drive the buzzer directly. Otherwise, Timer 1 can be programmed to activate the buzzer based on a pre-programmed value.

### **1.2.18 Battery Management**

There are four pins for battery management:

#### **BATOK**

This signal is derived from a comparator that is set to switch when the main battery reaches its end-of-life point. A transition to low will generate an FIQ interrupt. The operating system has to ensure the system is powered down to Standby mode to not drain the battery. Hardware inside the CL-PS7110 prevents the system from starting up unless a power-fail condition (NPWRFL deactive) is removed.

#### **NEXTPWR**

This input should be driven when an external power supply other than the main battery is powering the system. Only when this input is high with (NPWRFL deactive) the system may exit the standby state. This prevents the system from attempting to wake up.

#### **BATCHG**

When asserted this input will not generate an interrupt. It simply signals that there is no battery present. It may be generated by an external comparator that senses the battery voltage.

#### **NPWRFL**

This input will immediately put the system in standby state. The system is, however, assured that the DRAM access is completed and put into Self-refresh mode.

### **1.2.19 State Control**

The CL-PS7110 supports three basic power states: standby, idle, and operating. The standby state is the equivalent of the computer being switched 'off', that is, no display and the main oscillator shut down. The idle state is when the device is functioning, all oscillators are running, but the processor clock is halted while it waits for an event such as a key press. The operating state is the same as the idle state, except that the processor clock is running.

In the standby state, all system memory and states are maintained, and the system time is kept up to date. The main oscillator is disabled and the system is static, except for the low-power (32-kHz) watch crystal oscillator and divider chain to the realtime clock. The 'run' signal is driven low when in the standby state.

When first powered up or reset by the NPOR (Not Power On Reset) signal, the state is forced into the standby state. This is known as a 'cold' reset and is the only completely asynchronous reset to the CL-PS7110. The transition to the operating state is caused by a rising edge on the wake-up input signal (the user presses any wake-up keys), or by asserting a selected interrupt. Once self-refresh is enabled for the DRAMs, any transition to the standby state forces the DRAMs to the self-refresh state before stopping the oscillator.

Once in the operating state, the idle state is entered by writing to a special internal register location in the CL-PS7110. If an interrupt becomes active in the idle state, execution of the next instruction continues.

The system can also be forced into the standby state by hardware if the NPWRFL or NURESET inputs are forced low. In this case, the transition is synchronized with DRAM cycles to avoid any glitches or short cycles.

A write to another internal register location causes the transition from the operating state to the standby state.

The system-only transitions to the operating state from the standby state if either the NEXTPWR or BATOK, and the NPWRFL inputs are high. This prevents the system from attempting to start when the power supply is inadequate (for example, when the main batteries are dead).

Figure 1-8 shows a state diagram for the CL-PS7110.

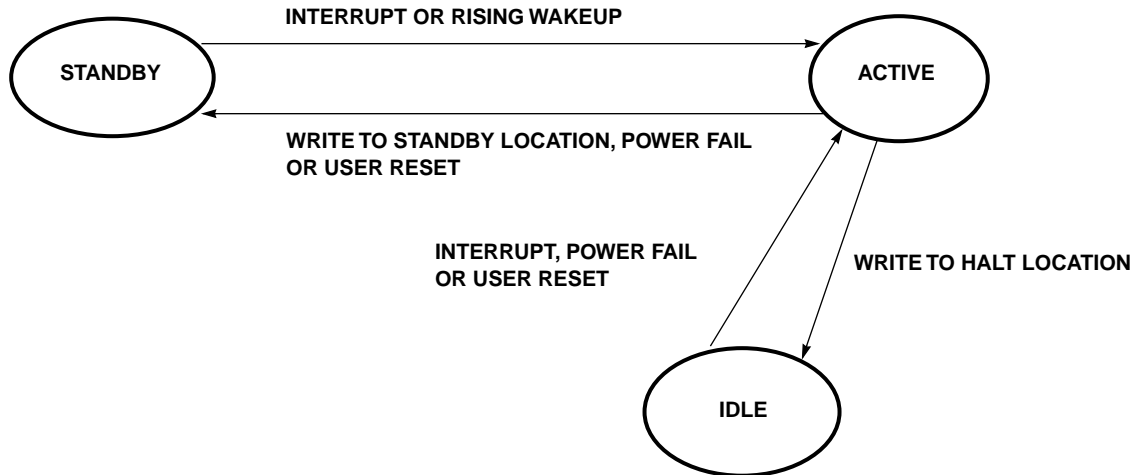

**Figure 1-8. State Diagram**

### 1.2.20 Power Management

The CL-PS7110 is designed for battery-based hand-held organizers/PDAs and wireless communicators. Minimizing power dissipation was a key design parameter. This required a holistic design approach in which many power-saving features provide significant power reduction.

Low power consumption was also a key goal in the development and VLSI implementation of the ARM710A core, cache and MMU.

Throughout the CL-PS7110, transition-avoidance techniques are used to minimize the power consumption of CMOS switching currents. For example, clocks to unused peripherals are 'gated-out' at source (where possible) rather than simply asserting the reset signal to the blocks. The main clock divider uses ripple count stages where possible to generate clocks that are not required to be synchronous with the main bus clock.

There are five FIFOs in the design. To save power and die area, a custom asynchronous ripple-through design is employed. Parameterized gates are used in the ripple-through data-latching stages of the FIFO (and in many places in the ARM710A) to optimize loading/drive ratios.

The on-chip oscillators and PLL save significant system power, removing the need for high-frequency clocks on the main PCB. For memory and I/O devices that require clocking, CL-PS7110 can provide the 18.432-MHz master clock externally, but this is only enabled for the duration of the I/O cycle. The use of a separate 32.768-kHz oscillator allows the Standby mode power consumption to be much lower than if the 1-Hz clock has been divided-down from the main oscillator.

In normal operation, the display of video data on the LCD requires a significant proportion of system power. To help minimize this, the DRAM row/column address lines are multiplexed-out in reverse order on the high-order bits of the main address bus. This means that the most frequently changing address bits

are driven onto the least heavily loaded address lines in a typical system, thus reducing overall system power.

CL-PS7110 uses a system of logic interlocks and timeouts to ensure that the device both enters Standby mode safely and restarts properly as the main oscillator starts. If external signals indicate that the main battery power level is low, the system will not attempt to wake up, thus avoiding a possible loss of volatile memory contents due to the failure of both main and backup batteries.

While the CPU is processing instructions, CL-PS7110 is in its normal operating state. By writing to a register location, the idle state can be entered, with both oscillators still running. In this state, DMA for video can continue but the processor clock is stopped pending an interrupt.

### **1.2.21 Software Model for Power Management**

The following section shows how to enter various modes:

#### ***Idle mode***

```
setup timer1
enable timer1 interrupt
halt the CPU (write to HWHalt register at 0x8000 0800)
```

On an interrupt (interrupts must be enabled), the system automatically wakes up and returns to operating mode.

#### ***Standby mode***

```
setup RTC Match value
enable RTC match interrupt
Write to STDBY register at 0x8000 0840
```

On an interrupt (interrupts must be enabled), the system automatically returns to normal operating mode.

### **1.2.22 Resets**

There are three asynchronous resets to the CL-PS7110: NPOR, NPWRFL, and NURESET. If any of these are active, a system reset is generated internally. This clears all internal registers in the CL-PS7110 to '0', except the DRAM Refresh Period register (DRFPR) and the Realtime Clock Data register (RTCDR), which are only cleared by an active NPOR signal. This also resets the ARM710A and causes it to start execution at the reset vector when the CL-PS7110 returns to its normal operating mode.

Internal to the CL-PS7110, three different signals are used to reset storage elements: NPOR, NSYSRES, and RUN. NPOR and RUN are also external signals.

#### ***NPOR (Not Power On Reset)***

This is the highest-priority reset signal. When active-low, it resets all storage elements in the CL-PS7110. NPOR active forces NSYSRES active and run low. NPOR is usually only active after the CL-PS7110 is first powered up. NPOR active clears all flags in the status register, apart from the Cold Flag (CLDFLG) bit, which is set.

**NSYSRES (Not System Reset)**

NSYSRES is generated internally to the CL-PS7110 if NPOR, NPWRFL, or NURESET are active. NSYSRES is the second-highest-priority reset signal, used to asynchronously reset most internal registers in the CL-PS7110. NSYSRES active forces RUN low. NSYSRES resets the CL-PS7110 and forces it into the standby state with no cooperation from software; the ARM710A is also reset. The memory controller places all DRAMs in Self-Refresh mode, preserving the contents through a system reset. This is why the DRAM Refresh Period register is not cleared by a system reset.

**RUN**

The RUN signal is high when the CL-PS7110 is in the operating or idle states, and low when in the standby state. The main system clock (MMCLK) is valid when RUN is high. RUN disables any peripheral block that is clocked from the main oscillator.

In general, a system reset clears all registers and RUN disables all peripherals that require a main clock. The following peripherals are disabled by a low level on RUN: UART (internal UART and IrDA SIR encoder), LCD (LCD controller), DCPMP (DC-to-DC converter drive), codec (codec interface) and SSI (synchronous serial interface).

## 2. PIN INFORMATION

### 2.1 Pin Diagram

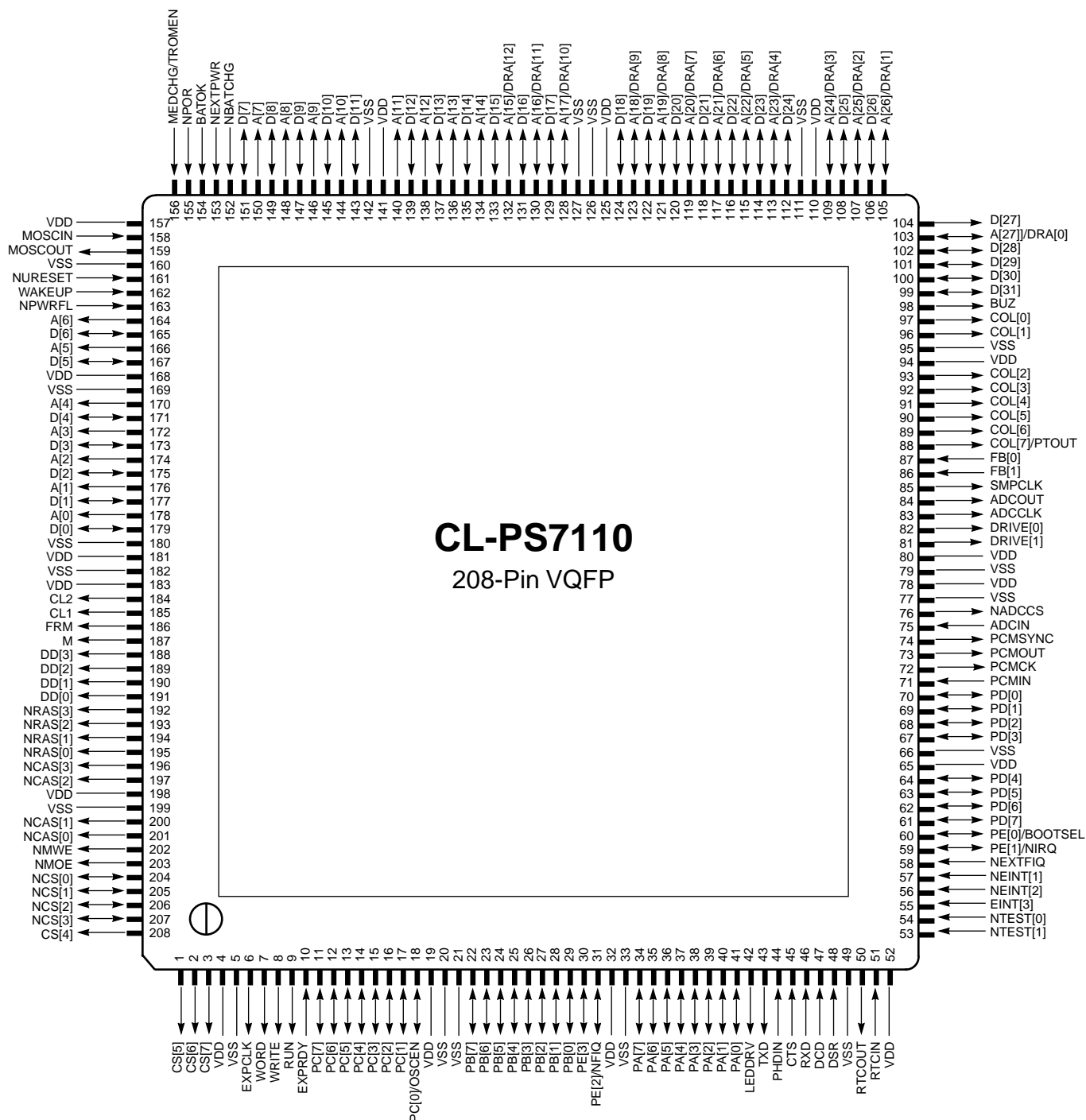

## 2.2 Pin Description Conventions

Abbreviations used for signal directions in this section are listed below:

Abbreviations	Description
I	A pin that functions as an input only.
O	A pin that functions as an output only.
I/O	A pin that operates as an input or an output.

## 2.3 Pin Descriptions

**Table 2-1. External Signal Functions**

Function	Signal Name	Signal	Description
Address and Data Bus	D[0–31]	I/O	32-bit system data bus for DRAM, ROM, and memory-mapped expansion.
	A[0–14]	O	Least-significant 15 bits of system <b>byte</b> address during ROM and expansion cycles.
	A[15]/ DRA[12]– A[27]/DRA[0]	O	13-bit multiplexed DRAM <b>word</b> address during DRAM cycles or address bits 16 to 27 of system <b>byte</b> address during ROM and expansion cycles.
Memory and Expansion Interface	NRAS[0–3]	O	DRAM RAS outputs to DRAM banks 0–3.
	NCAS[0–3]	O	DRAM CAS outputs for bytes 0 to 3 within 32-bit word.
	NMOE	O	DRAM, ROM, and expansion output enable.
	NMWE	O	DRAM, ROM, and expansion write enable.
	NCS[0–3]	O	Expansion channel I/O strobes. Active-low SRAM-like chip selects for expansion.
	CS[4–7]	O	Expansion channel I/O strobes. Active-high SRAM-like chip selects for expansion.
	EXPRDY	I	Expansion channel ready. External expansion drives this low to extend bus cycle.
	WRITE	O	Transfer direction: low during reads; high during writes from the CL-PS7110.
	WORD	O	Word access enable. Driven high during word-wide cycles; low during byte-wide cycles.
	EXPCLK	O	Expansion clock output. Clock output at the same phase and speed as the CPU clock. Free-running or active only during expansion I/O cycles.
Interrupts	MEDCHG	I	Media changed input. Active-high door or expansion-change de-glitched input.
	NEXTFIQ	I	External active-low fast interrupt request input.
	EINT[3]	I	External active-high interrupt request input.
	NEINT[1–2]	I	Two general-purpose, active-low interrupt inputs.



**Table 2-1. External Signal Functions** (cont.)

Function	Signal Name	Signal	Description
Power Management	NPWRFL	I	Power fail input. Active-low de-glitched input to force system into the standby state.
	BATOK	I	Main battery OK input. Falling edge generates a FIQ, a low level in standby inhibits system start up; de-glitched input.
	NEXTPWR	I	External power sense. Must be driven low if the system is powered by external source.
	NBATCHG	I	New battery sense; driven low if battery voltage falls below the 'no-battery' threshold.
State Control	NPOR	I	Power on reset input. Active-low input completely resets the system.
	RUN	O	System active output; high when system is active or idle; low while in the standby state.
	WAKEUP	I	Wake up input signal. Rising edge forces system into operating state; active after a power on reset.
	NURESET	I	User reset input. Active-low input from user reset button.
Codec Interface	PCMCK	O	Codec clock output.
	PCMSYNC	O	Codec synchronization, pulse output.
	PCMOUT	O	Codec serial data output.
	PCMIN	I	Codec serial data input.
Synchronous Serial Interface	ADCCLK	O	Serial ADC clock output.
	SMPLCK	O	Serial ADC sample clock, can be disabled.
	NADCCS	O	Serial ADC active-low chip select and synchronization output.
	ADCOUT	O	Serial ADC serial data output.
	ADCIN	I	Serial ADC serial data input.
IrDA and RS232 Interface	LEDDRV	O	Infrared LED drive output.
	PHDIN	I	Photo diode input.
	TxD	O	RS232 Tx output.
	RxD	I	RS232 Rx input.
	DSR	I	RS232 DSR input.
	DCD	I	RS232 DCD input.
	CTS	I	RS232 CTS input.

**Table 2-1. External Signal Functions** *(cont.)*

Function	Signal Name	Signal	Description
LCD	DD[0–3]	O	LCD serial display data.
	CL[1]	O	LCD line clock.
	CL[2]	O	LCD pixel clock.
	FRM	O	LCD frame synchronization pulse output.
	M	O	LCD AC bias drive.
Keyboard	COL[0–7]	O	Keyboard column drives.
Buzzer Drive	BUZ	O	Buzzer drive output.
General-Purpose I/O	PA[0–7]	I/O	Port A I/O.
	PB[0–7]	I/O	Port B I/O.
	PC[0–7]	I/O	Port C I/O.
	PD[0–7]	I/O	Port D I/O.
	PE[0–3]	I/O	Port E I/O.
DC-to-DC Drives	DRIVE[0–1]	O	DC-to-DC drive outputs.
	FB[0–1]	I	DC-to-DC feedback inputs.
Test	NTEST[0–1]	I	Test mode select inputs.
Oscillators	MOSCIN/ MOSOUT	I O	Main 3.6864-MHz oscillator for 18.432-MHz PLL.
	RTCIN/ RTCOUT	I O	Realtime clock 32.768-kHz oscillator.

## 2.4 Pin Descriptions

Table 2-2. Numeric Pin Listing<sup>a</sup>

Pin No.	Signal	Buffer <sup>b</sup>	Reset and Pin Test Rest State
1	CS[5]	I/O - strength 1	Low
2	CS[6]	I/O - strength 1	Low
3	CS[7]	I/O - strength 1	Low
4	VDD	Pad power	–
5	VSS	Pad power	–
6	EXPCLK	I/O - strength 1	Low
7	WORD	I/O - strength 1	Low
8	WRITE	I/O - strength 1	Low
9	RUN	I/O - strength 1	Low
10	EXPRDY	I/O - strength 1	Input
11	PC[7]	I/O - strength 1	Low
12	PC[6]	I/O - strength 1	Low
13	PC[5]	I/O - strength 1	Low
14	PC[4]	I/O - strength 1	Low
15	PC[3]	I/O - strength 1	Low
16	PC[2]	I/O - strength 1	Low
17	PC[1]	I/O - strength 1	Low
18	PC[0]/OSCEN	I/O - strength 1	Low
19	VDD	Pad power	–
20	VSS	Pad power	–
21	VSS	Core power	–
22	PB[7]	I/O - strength 1	Input
23	PB[6]	I/O - strength 1	Input
24	PB[5]	I/O - strength 1	Input
25	PB[4]	I/O - strength 1	Input
26	PB[3]	I/O - strength 1	Input
27	PB[2]	I/O - strength 1	Input

Table 2-2. Numeric Pin Listing<sup>a</sup> (cont.)

Pin No.	Signal	Buffer <sup>b</sup>	Reset and Pin Test Rest State
28	PB[1]	I/O - strength 1	Input
29	PB[0]	I/O - strength 1	Input
30	PE[3]	I/O - strength 1	Input
31	PE[2]/NFIQ	I/O - strength 1	Input
32	VDD	Pad power	–
33	VSS	Pad power	–
34	PA[7]	I/O - strength 1	Input
35	PA[6]	I/O - strength 1	Input
36	PA[5]	I/O - strength 1	Input
37	PA[4]	I/O - strength 1	Input
38	PA[3]	I/O - strength 1	Input
39	PA[2]	I/O - strength 1	Input
40	PA[1]	I/O - strength 1	Input
41	PA[0]	I/O - strength 1	Input
42	LEDDR	I/O - strength 1	Low
43	TXD	I/O - strength 1	High
44	PHDIN	I/O - strength 1	Input
45	CTS	I/O - strength 1	Input
46	RXD	I/O - strength 1	Input
47	DCD	I/O - strength 1	Input
48	DSR	I/O - strength 1	Input
49	VSS	32K Oscillator power	–
50	RTCOUT	32K Oscillator	X
51	RTCIN	32K Oscillator	X
52	VDD	32K Oscillator power	–
53	NTEST[1]	–	Input
54	NTEST[0]	–	Input

**Table 2-2. Numeric Pin Listing<sup>a</sup> (cont.)**

Pin No.	Signal	Buffer <sup>b</sup>	Reset and Pin Test Rest State
55	EINT[3]	–	Input
56	NEINT[2]	–	Low
57	NEINT[1]	–	Low
58	NEXTFIQ	–	Low
59	PE[1]/NIRQ	I/O - strength 1	I/O
60	PE[1]/BOOTSEL	I/O - strength 1	I/O
61	PD[7]	I/O - strength 3	Low
62	PD[6]	I/O - strength 3	Low
63	PD[5]	I/O - strength 3	Low
64	PD[4]	I/O - strength 3	Low
65	VDD	Pad power	–
66	VSS	Pad power	–
67	PD[3]	I/O - strength 1	Low
68	PD[2]	I/O - strength 1	Low
69	PD[1]	I/O - strength 1	Low
70	PD[0]	I/O - strength 1	Low
71	PCMIN	I/O - strength 1	Input
72	PCMCK	I/O - strength 1	Low
73	PCMOUT	I/O - strength 1	Low
74	PCMSYNC	I/O - strength 1	Low
75	ADCIN	I/O - strength 1	Input
76	NADCCS	I/O - strength 1	High
77	VSS	Core power	–
78	VDD	Core power	–
79	VSS	Pad power	–
80	VDD	Pad power	–
81	DRIVE[1]	I/O - strength 4	High/Low

**Table 2-2. Numeric Pin Listing<sup>a</sup> (cont.)**

Pin No.	Signal	Buffer <sup>b</sup>	Reset and Pin Test Rest State
82	DRIVE[0]	I/O - strength 4	High/Low
83	ADCCLK	I/O - strength 1	Low
84	ADCOUT	I/O - strength 1	Low
85	SMPLCK	I/O - strength 1	Low
86	FB1	I/O - strength 1	Input
87	FB0	I/O - strength 1	Input
88	COL[7]/PTOUT	I/O - strength 1	High
89	COL[6]	I/O - strength 1	High
90	COL[5]	I/O - strength 1	High
91	COL[4]	I/O - strength 1	High
92	COL[3]	I/O - strength 1	High
93	COL[2]	I/O - strength 1	High
94	VDD	Pad power	–
95	VSS	Pad power	–
96	COL[1]	I/O - strength 1	High
97	COL[0]	I/O - strength 1	High
98	BUZ	I/O - strength 1	Low
99	D[31]	I/O - strength 1	Low
100	D[30]	I/O - strength 1	Low
101	D[29]	I/O - strength 1	Low
102	D[28]	I/O - strength 1	Low
103	A[27]	I/O - strength 1	Low
104	A[27]/DRA[0]	I/O - strength 2	Low
105	A[26]/DRA[1]	I/O - strength 2	Low
106	D[26]	I/O - strength 1	Low
107	A[25]/DRA[2]	I/O - strength 1	Low
108	D[25]	I/O - strength 1	Low

Table 2-2. Numeric Pin Listing<sup>a</sup> (cont.)

Pin No.	Signal	Buffer <sup>b</sup>	Reset and Pin Test Rest State
109	A[24]/DRA[3]	I/O - strength 1	Low
110	VDD	Pad power	–
111	VSS	Pad power	–
112	D[24]	I/O - strength 1	Low
113	A[23]/DRA[4]	I/O - strength 1	Low
114	D[23]	I/O - strength 1	Low
115	A[22]/DRA[5]	I/O - strength 1	Low
116	D[22]	I/O - strength 1	Low
117	A[21]/DRA[6]	I/O - strength 1	Low
118	D[21]	I/O - strength 1	Low
119	A[20]/DRA[7]	I/O - strength 1	Low
120	D[20]	I/O - strength 1	Low
121	A[19]/DRA[8]	I/O - strength 1	Low
122	D[19]	I/O - strength 1	Low
123	A[18]/DRA[9]	I/O - strength 1	Low
124	D[18]	Pad power	–
125	VDD	Pad power	–
126	VSS	Core power	–
127	VSS	Core power	–
128	A[17]/DRA[10]	I/O - strength 1	Low
129	D[17]	I/O - strength 1	Low
130	A[16]/DRA[11]	I/O - strength 1	Low
131	D[16]	I/O - strength 1	Low
132	A[15]/DRA[12]	I/O - strength 1	Low
133	D[15]	I/O - strength 1	Low
134	A[14]	I/O - strength 1	Low
135	D[14]	I/O - strength 1	Low
136	A[13]	I/O - strength 1	Low

Table 2-2. Numeric Pin Listing<sup>a</sup> (cont.)

Pin No.	Signal	Buffer <sup>b</sup>	Reset and Pin Test Rest State
137	D[13]	I/O - strength 1	Low
138	A[12]	I/O - strength 1	Low
139	D[12]	I/O - strength 1	Low
140	A[11]	I/O - strength 1	Low
141	VDD	Pad power	–
142	VSS	Core power	–
143	D[11]	I/O - strength 1	Low
144	A[10]	I/O - strength 1	Low
145	D[10]	I/O - strength 1	Low
146	A[9]	I/O - strength 1	Low
147	D[9]	I/O - strength 1	Low
148	A[8]	I/O - strength 1	Low
149	D[8]	I/O - strength 1	Low
150	A[7]	I/O - strength 1	Low
151	D[7]	I/O - strength 1	Low
152	NBATCHG	I/O - strength 1	Low
153	NEXTPWR	I/O - strength 1	Low
154	BATOK	I/O - strength 1	Low
155	NPOR	I/O - strength 1	Low
156	MEDCHG/ TROMEN	I/O - strength 1	Low
157	VDD	Pad power	–
158	MOSCIN	3M6864 Osc	X
159	MOSCOU	3M6864 Osc	X
160	VSS	Osc power	–
161	NURESET	Schmitt I/O	Input
162	WAKEUP	Schmitt I/O	Input
163	NPWRFL	I/O - strength 1	Input

**Table 2-2. Numeric Pin Listing<sup>a</sup> (cont.)**

Pin No.	Signal	Buffer <sup>b</sup>	Reset and Pin Test Rest State
164	A[6]	I/O - strength 1	Low
165	D[6]	I/O - strength 1	Low
166	A[5]	I/O - strength 1	Low
167	D[5]	I/O - strength 1	Low
168	VDD	I/O - strength 1	Low
169	VSS	Pad power	–
170	A[4]	I/O - strength 1	Low
171	D[4]	I/O - strength 1	Low
172	A[3]	I/O - strength 1	Low
173	D[3]	I/O - strength 1	Low
174	A[2]	I/O - strength 1	Low
175	D[2]	I/O - strength 1	Low
176	A[1]	I/O - strength 1	Low
177	D[1]	I/O - strength 1	Low
178	A[0]	I/O - strength 1	Low
179	D[0]	I/O - strength 1	Low
180	VSS	Core power	–
181	VDD	Core power	–
182	VSS	Pad power	–
183	VDD	Pad power	–
184	CL2	I/O - strength 1	Low
185	CL1	I/O - strength 1	Low
186	FRM	I/O - strength 1	Low
187	M	I/O - strength 1	Low
188	DD[3] <sup>a</sup>	I/O - strength 1	Low
189	DD[2] <sup>a</sup>	I/O - strength 1	Low
190	DD[1] <sup>a</sup>	I/O - strength 1	Low
191	DD[0] <sup>a</sup>	I/O - strength 1	Low

**Table 2-2. Numeric Pin Listing<sup>a</sup> (cont.)**

Pin No.	Signal	Buffer <sup>b</sup>	Reset and Pin Test Rest State
192	NRAS[3]	I/O - strength 1	High
193	NRAS[2]	I/O - strength 1	High
194	NRAS[1]	I/O - strength 1	High
195	NRAS[0]	I/O - strength 1	High
196	NCAS[3]	I/O - strength 1	High
197	NCAS[2]	I/O - strength 1	High
198	VDD	Pad power	–
199	VSS	Pad power	–
200	NCAS[1]	I/O - strength 1	High
201	NCAS[0]	I/O - strength 1	High
202	NMWE	I/O - strength 1	High
203	NMOE	I/O - strength 1	High
204	NCS[0]	I/O - strength 1	High
205	NCS[1]	I/O - strength 1	High
206	NCS[2]	I/O - strength 1	High
207	NCS[3]	I/O - strength 1	High
208	CS[4]	I/O - strength 1	Low

<sup>a</sup> DD0–DD3 must be pulled-up or -down using a 100-kΩ resistor.

<sup>b</sup> See [Table 4-3 on page 70](#).

### 3. PROGRAMMING INTERFACE

#### 3.1 Memory Map

The lower 2 Gbytes of the address space is allocated to ROM and expansion space; the upper Gbyte of address space is allocated to DRAM. The remaining Gbyte, less 4K for internal registers, is not accessible in the CL-PS7110. Program the MMU in the CL-PS7110 to generate an abort exception for access to this area.

Internal peripherals are addressed through a set of internal memory locations, from hexadecimal address 8000.000–8000.0FFF, are known as the internal registers in the CL-PS7110.

Table 3-1 shows the mapping of the 4-Gbyte address range of the ARM710A microprocessor in the CL-PS7110.

**Table 3-1. Memory Map**

F000.0000	DRAM BANK 3	256 MBYTES
E000.0000	DRAM BANK 2	256 MBYTES
D000.0000	DRAM BANK 1	256 MBYTES
C000.0000	DRAM BANK 0	256 MBYTES
8000.1000	NOT USED	~1 GBYTE
8000.0000	INTERNAL REGISTERS	4 KBYTES
7000.0000	EXPANSION (CS7)	256 MBYTES
6000.0000	EXPANSION (CS6)	256 MBYTES
5000.0000	EXPANSION (CS5)	256 MBYTES
4000.0000	EXPANSION (CS4)	256 MBYTES
3000.0000	EXPANSION (CS3)	256 MBYTES
2000.0000	EXPANSION (CS2)	256 MBYTES
1000.0000	ROM BANK 1 (CS1)	256 MBYTES
0000.0000	ROM BANK 0 (CS0)	256 MBYTES

### 3.2 Internal Registers

Table 3-2 shows all internal registers in the CL-PS7110. A 4-Kbyte segment of memory, in the range 8000.0000–8000.0FFF, is reserved for CL-PS7110 internal use. Accesses in this range do not cause any external bus activity unless Debug mode is enabled. Writes to bits that are not explicitly defined in the internal area are illegal, and have no effect. Reads from bits not explicitly defined in the internal area are legal, but read undefined values. All the internal addresses can only be accessed as 32-bit words, and are always on a word boundary (except for the PIA Port registers, which can be accessed as bytes). Address bits in the range A0–A5 are not decoded. This means each internal register is valid for 64 bytes (that is, the SYSFLG register appears at locations 8000.0140–8000.017C). The PIA Port registers are byte-wide, but can be accessed as a word. These registers additionally decode A0 and A1. All addresses are hexadecimal.

**Table 3-2. Internal I/O Memory Locations**

Address	Name	R/W	Size	Comments
8000.0000	PADR	RW	8	Port A Data register
8000.0001	PBDR	RW	8	Port B Data register
8000.0002	PCDR	RW	8	Port C Data register
8000.0003	PDDR	RW	8	Port D Data register
8000.0040	PADDR	RW	8	Port A Data Direction register
8000.0041	PBDDR	RW	8	Port B Data Direction register
8000.0042	PCDDR	RW	8	Port C Data Direction register
8000.0043	PDDDR	RW	8	Port D Data Direction register
8000.0080	PEDR	RW	4	Port E Data register
8000.00C0	PEDDR	RW	4	Port E Data Direction register
8000.0100	SYSCON	RW	32	System Control register
8000.0140	SYSFLG	RD	32	System Status Flags register
8000.0180	MEMCFG1	RW	32	Expansion and ROM Memory Configuration Register 1
8000.01C0	MEMCFG2	RW	32	Expansion and ROM Memory Configuration Register 2
8000.0200	DRFPR	RW	8	DRAM Refresh Period register
8000.0240	INTSR	RD	16	Interrupt Status register
8000.0280	INTMR	RW	16	Interrupt Mask register
8000.02C0	LCDCON	RW	32	LCD Control register
8000.0300	TC1D	RW	16	Read/write data to TC1
8000.0340	TC2D	RW	16	Read/write data to TC2
8000.0380	RTCDR	RW	32	Realtime Clock Data register
8000.03C0	RTCMR	RW	32	Realtime Clock Match register



**Table 3-2. Internal I/O Memory Locations** (cont.)

Address	Name	R/W	Size	Comments
8000.0400	PMPCON	RW	12	DC-to-DC Pump Control register
8000.0440	CODR	RW	8	Codec Data I/O register
8000.0480	UARTDR	RW	8	UART FIFO Data register
8000.04C0	UBLCR	RW	32	UART Bit Rate and Line Control register
8000.0500	SYNCIO	RW	16	Synchronous Serial I/O Data register
8000.0540	PALLSW	RW	32	Least-significant 32-bit word of LCD Palette register
8000.0580	PALMSW	RW	32	Most-significant 32-bit word of LCD Palette register
8000.05C0	STFCLR	WR	–	Write to clear all start up reason flags
8000.0600	BLEOI	WR	–	Write to clear Battery Low interrupt
8000.0640	MCEOI	WR	–	Write to clear Media Changed interrupt
8000.0680	TEOI	WR	–	Write to clear Tick and Watchdog interrupt
8000.06C0	TC1EOI	WR	–	Write to clear TC1 interrupt
8000.0700	TC2EOI	WR	–	Write to clear TC2 interrupt
8000.0740	RTCEOI	WR	–	Write to clear RTC Match interrupt
8000.0780	UMSEOI	WR	–	Write to clear UART Modem Status Changed interrupt
8000.07C0	COEOI	WR	–	Write to clear Codec Sound interrupt
8000.0800	HALT	WR	–	Write to enter idle state
8000.0840	STDBY	WR	–	Write to enter standby state
8000.0880–BFFF.FFFF	Reserved	–	–	Write has no effect; read is undefined

All internal registers in the CL-PS7110 are reset (cleared to '0') by a system reset (NPOR, NRESET, or NPWRFL become active), except for the DRAM Refresh Period register (DRFPR), which is only reset when NPOR becomes active. In addition, the Realtime Clock Data register (RTCDR) and Realtime Clock Match register (RTCMR) are never reset. This ensures that the DRAM contents and system time are preserved through a user reset or power-fail condition.

### 3.2.1 PADR — Port A Data Register

Values written to this 8-bit read/write register are output on the Port A pins if the corresponding data direction bits are set **high** (port output). Values read from this register reflect the external state of Port A, not necessarily the value written to it. All bits are cleared by a system reset.

### 3.2.2 PBDR — Port B Data Register

Values written to this 8-bit read/write register are output on the Port B pins if the corresponding data direction bits are set **high** (port output). Values read from this register reflect the external state of Port B, not necessarily the value written to it. All bits are cleared by a system reset.

### 3.2.3 PCDR — Port C Data Register

Values written to this 8-bit read/write register are output on the Port C pins if the corresponding data direction bits are set **low** (port output). Values read from this register reflect the external state of Port C, not necessarily the value written to it. All bits are cleared by a system reset.

### 3.2.4 PDDR — Port D Data Register

Values written to this 8-bit read/write register are output on the Port D pins if the corresponding data direction bits are set **low** (port output). Values read from this register reflect the external state of Port C, not necessarily the value written to it. All bits are cleared by a system reset.

### 3.2.5 PADDR — Port A Data Direction Register

Bits set in this 8-bit read/write register select the corresponding pin in Port A to become an output; clearing a bit sets the pin to input. All bits are cleared by a system reset so that Port A is **input by default**.

### 3.2.6 PBDDR — Port B Data Direction Register

Bits set in this 8-bit read/write register select the corresponding pin in Port B to become an output; clearing a bit sets the pin to input. All bits are cleared by a system reset so that Port A is **input by default**.

### 3.2.7 PCDDR — Port C Data Direction Register

Bits cleared in this 8-bit read/write register select the corresponding pin in Port C to become an output; setting a bit sets the pin to input. All bits are cleared by a system reset so that Port C is **output by default**.

### 3.2.8 PDDDR — Port D Data Direction Register

Bits cleared in this 8-bit read/write register select the corresponding pin in Port D to become an output; setting a bit sets the pin to input. All bits are cleared by a system reset so that Port D is **output by default**.

### 3.2.9 PEDR — Port E Data Register

Values written to this 4-bit read/write register are output on Port E pins if the corresponding data direction bits are set high (port output). Values read from this register reflect the external state of Port E, not necessarily the value written to it. All bits are cleared by a system reset.

### 3.2.10 PEDDR — Port E Data Direction Register

Bits set in this 4-bit read/write register select the corresponding pin in Port E to become an output; clearing a bit sets the pin to input. All bits are cleared by a system reset so that Port E is **input by default**.

### 3.2.11 SYSCON — System Control Register

The System Control register is a 24-bit read/write register that controls all the general configuration of the CL-PS7110 as well as modes for peripheral devices. All bits in this register are cleared by a *system reset*. The bits in SYSCON are defined in [Table 3-3](#).

**Table 3-3. Bits in SYSCON**

7	6	5	4	3				0
TC2S	TC2M	TC1S	TC1M	Keyboard scan				
15	14	13	12	11	10	9	8	
SIREN	CDENRX	CDENTX	LCDEN	DBGEN	BZMOD	BZTOG	UARTEN	
23	22	21	20	19	18	17	16	
Reserved			IRTXM	WAKEDIS	EXCKEN	ADCKSEL		

Keyboard Scan is a 4-bit field that defines the state of the keyboard column drives, as shown in [Table 3-4](#).

**Table 3-4. Keyboard Scan Field**

Keyboard Scan	Column
0 <sup>a</sup>	All driven high
1 <sup>a</sup>	All driven low
2–7 <sup>a</sup>	All high impedance (tristate)
8	Column 0 only driven high all others high impedance
9	Column 1 only driven high all others high impedance
10	Column 2 only driven high all others high impedance
11	Column 3 only driven high all others high impedance
12	Column 4 only driven high all others high impedance
13	Column 5 only driven high all others high impedance
14	Column 6 only driven high all others high impedance
15	Column 7 only driven high all others high impedance

<sup>a</sup> Used for test purposes only.

<b>TC1M</b>	Timer Counter 1 (TC1) mode. Setting this bit sets TC1 to Prescale mode, clearing it sets Free-running mode.
<b>TC1S</b>	Timer Counter 1 clock source. Setting this bit sets the TC1 clock source to 512 kHz, clearing it sets the clock source to 2 kHz.
<b>TC2M</b>	Timer Counter 2 (TC2) mode. Setting this bit sets TC2 to Prescale mode, clearing it sets Free-running mode.
<b>TC2S</b>	Timer Counter 2 clock source. Setting this bit sets the TC2 clock source to 512 kHz, clearing it sets the clock source to 2 kHz.
<b>UARTEN</b>	Internal UART enable bit. Setting this bit enables the internal UART.
<b>BZTOG</b>	Bit to drive buzzer directly.
<b>BZMOD</b>	This bit sets the Buzzer Drive mode. 0 = the buzzer drive is connected directly to the BZTOG bit. 1 = the buzzer drive is connected to the TC1 under-flow bit.
<b>DBGEN</b>	Setting this bit enables Debug mode. In this mode all internal accesses are output as if they were reads or writes to expansion memory addressed by CS6. CS6 remains active in its standard address range. In addition, the internal interrupt request and fast interrupt request signals to the ARM710A microprocessor are output on port E bits 1 and 2 in Debug mode: CS6 = CS6/internal I/O strobe PE1 = NIRQ PE2 = NFIQ
<b>LCDEN</b>	LCD enable bit. Setting this bit enables the LCD controller.
<b>CDENTX</b>	Codec interface enable Tx bit. Setting this bit enables the codec interface for data transmission to an external codec device.
<b>CDENRX</b>	Codec interface enable Rx bit. Setting this bit enables the codec interface for data reception from an external codec device.
<b>SIREN</b>	HP SIR protocol encoding enable bit. This bit has no effect if the UART is not enabled.
<b>EXCKEN</b>	External expansion clock enable. If this bit is set, the EXPCLK is enabled continuously; it is the same speed and phase as the CPU clock, and free-run all the time the main oscillator is running. This bit should not be left set for power consumption reasons. If the system enters the <i>standby</i> state, the EXPCLK is undefined. If this bit is clear, EXPCLK is active during memory cycles to the expansion slots that have external wait-state generation enabled.

**ADCKSEL** Microwire®/SPI® peripheral clock speed select. This 2-bit field selects the frequency of the ADC sample clock, which is twice the frequency of the synchronous serial ADC interface clock. [Table 3-5](#) shows the available frequencies.

**Table 3-5. ADCCLK Frequencies**

ADCKSEL	ADC Sample frequency (kHz) — SMPCLK	ADC interface frequency (kHz) — ADCCLK
00	8	4
01	32	16
10	128	64
11	256	128

**WAKEDIS** If this bit is set, switch-on (through the wake-up input) is disabled.

**IRTXM** IrDA Tx mode bit. This bit controls the IrDA encoding strategy. Clearing this bit means each '0' bit transmitted is represented as a pulse of width 3/16th of the bit rate period. Setting this bit means each '0' bit is represented as a pulse of width 3/16th of the period of 115,000 bit rate clock, that is, 1.6  $\mu$ s, regardless of the selected bit rate. Setting this bit reduces power consumption, but probably reduces transmission distances.

**Bits 21–23** Reserved. Write has no effect, always reads '0'.

### 3.2.12 SYSFLG — System Status Flags Register

The System Status Flags register is a 32-bit read-only register that indicates various system information. The bits in this register are defined in [Table 3-6](#).

**Table 3-6. Bits in the System Status Flags Register**

7		4		3		2		1		0	
DID				WUON		WUDR		DCDET		MCDR	
15		14		13		12		11		10	
CLDFLG		PFFLG		RSTFLG		NBFLG		UBUSY		DCD	
23		22		21				16			
UTXFF		URXFE		RTCDIV							
31		30		29		28		27		26	
VERID		Reserved		Reserved		BOOT8BIT		SSIBUSY		CTXFF	
								25		24	
										CRXFE	

<b>MCDR</b>	Media changed direct read. This bit reflects the non-latched status of the media changed input.
<b>DCDET</b>	This bit is set if the main adapter is powering the system (the inverted state of the NDCDET input pin).
<b>WUDR</b>	Wake-up direct read. This bit reflects the non-latched state of the wake-up signal.
<b>WUON</b>	This bit is set if the system is brought out of standby by a rising edge on the wake-up signal. It is cleared by a system reset or by writing to the HALT or STDBY locations.
<b>DID</b>	Display ID nibble. This 4-bit nibble reflects the latched state of the four LCD data lines. The state of the four LCD data lines is latched by the LCDEN bit and will always reflect the last state of these lines before the LCD controller was enabled. These bits identify the LCD display panel.
<b>CTS</b>	This bit reflects the current status of the clear to send (CTS) modem-control input to the built-in UART.
<b>DSR</b>	This bit reflects the current status of the data set ready (DSR) modem control input to the built-in UART.
<b>DCD</b>	This bit reflects the current status of the data carrier detect (DCD) modem control input to the built in UART.
<b>UBUSY</b>	UART transmitter busy. This bit is set while the internal UART is busy transmitting data, it is guaranteed to remain set until the complete byte has been sent, including all stop bits.
<b>NBFLG</b>	New battery flag. This bit is set if a low-to-high transition has occurred on the NBATCHG input; it is cleared by writing to the STFCLR location.
<b>RSTFLG</b>	Reset flag. This bit is set if the RESET button is pressed, forcing the NURESET input low. It is cleared by writing to the STFCLR location.
<b>PFFLG</b>	Power fail flag. This bit is set if the system has been reset by the power fail input pin, it is cleared by writing to the STFCLR location.
<b>CLDFLG</b>	Cold start flag. This bit is set if the CL-PS7110 has been reset with a power on reset; it is cleared by writing to the STFCLR location.
<b>RTCDIV</b>	This 6-bit field reflects the number of 64-Hz ticks that have passed since the last increment of the RTC. It is the output of the divide-by-64 chain that divides the 64-Hz tick clock down to 1 Hz for the RTC. The MSB is the 32-Hz output, the LSB is the 1-Hz output.
<b>URXFE</b>	UART receiver FIFO empty. The meaning of this bit depends on the state of the UFI-FOEN bit in the UART Bit Rate and Line Control register. If the FIFO is disabled, this bit is set when the Rx Holding register is empty. If the FIFO is enabled the URXFE bit is set when the Rx FIFO is empty.
<b>UTXFF</b>	UART transmit FIFO full. The meaning of this bit depends on the state of the UFI-FOEN bit in the UART Bit Rate and Line Control register. If the FIFO is disabled, this bit is set when the Tx Holding register is full. If the FIFO is enabled the UTXFF bit is set when the Tx FIFO is full.

<b>CRXFE</b>	Codec Rx FIFO empty bit. This is set if the 16-byte codec Rx FIFO is empty.
<b>CTXFF</b>	Codec Tx FIFO full bit. This is set if the 16-byte codec Tx FIFO is full.
<b>SSIBUSY</b>	Synchronous serial interface busy bit. This bit is set while data is shifted in or out of the synchronous serial interface, when clear data is valid to read.
<b>BOOT8BIT</b>	This bit indicates the default (power-on reset) bus width of the ROM interface. If set, the initial bus width is 8 bits, if clear it is 32 bits. See Memory Configuration Register 1 for more details on the ROM interface bus width. The state of this bit is determined by the state of Port E bit 0 during power-on reset. LOW during power-on reset clears the BOOT8BIT bit and the system boots from a 32-bit ROM, HIGH during power-on reset sets the BOOT8BIT bit and the system boots from a 8-bit ROM.
<b>Reserved</b>	Write has no effect, always reads '0'.
<b>VERID</b>	Version ID bits. These two bits determine the version identification for the CL-PS7110. Reads '0' for the first version.

### 3.2.13 MEMCFG1 — Memory Configuration Register 1

Expansion and ROM space is selected by one of eight chip selects. Each chip select is active for 256 Mbytes and the timing and bus transfer width can be programmed individually. This is accomplished by programming 8-byte-wide fields contained in two 32-bit registers, MEMCFG1 and MEMCFG2. All bits in these registers are cleared by a system reset.

The Memory Configuration Register 1 is a 32-bit read/write register that sets the configuration of the four expansion and ROM selects NCS0–NCS3. Each select is configured with a 1-byte field, starting with expansion select 0.

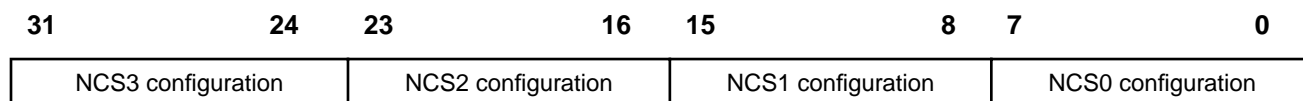

### 3.2.14 MEMCFG2 — Memory Configuration Register 2

The Memory Configuration Register 2 is a 32-bit read/write register that sets the configuration of the four expansion and ROM selects CS4–CS7. Each select is configured with a 1-byte field, starting with expansion select 4.

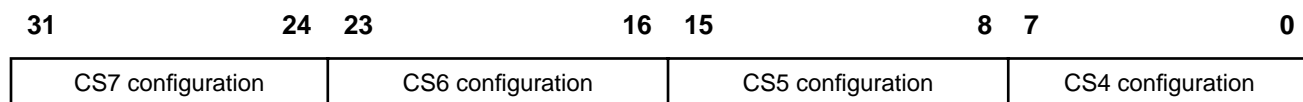

Each of the eight byte fields in the Memory Configuration registers are identical and define the number of wait states, the bus width, enable EXPCLK output during accesses and enable sequential mode access. This byte field is defined below.

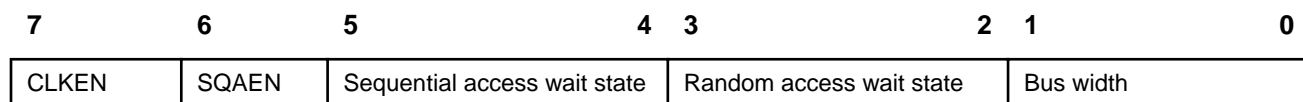

**Table 3-7** defines the bus width field. Note that the effect of this field is dependent on the BOOT8BIT bit, which can be read in the SYSFLG register. All bits in the Memory Configuration register are cleared by a system reset and the state of the BOOT8BIT bit is determined by the Port E bit 0 pin on the CL-PS7110 during power-on reset. Pulling Port E bit 0 either low or high during power-on reset allows the CL-PS7110 to boot from either 32-bit-wide or 8-bit-wide ROMs.

**Table 3-7. Values of the Bus Width Field**

Bus Width Field	BOOT8BIT	Expansion Transfer Mode	Port E Bit 0 During Power-On Reset
00	0	32-bit-wide bus access	Low
01	0	16-bit-wide bus access	Low
10	0	8-bit-wide bus access	Low
11	0	PCMCIA mode	Low
00	1	8-bit-wide bus access	High
01	1	PCMCIA mode	High
10	1	32-bit-wide bus access	High
11	1	16-bit-wide bus access	High

When the bus width field is programmed to PCMCIA mode, the bus width and bus conversion is defined by the state of A27 and A26. **Table 3-8** defines the bus width and bus conversion for values of A27 and A26. Word bus conversion converts an ARM 32-bit word access into a series of byte or 16-bit accesses. A special case is 16-bit I/O accesses (A26 and A27 high). In this case 32-bit ARM word accesses are not converted into two 16-bit access, this allows individual 16-bit register access. In this mode, D16 to D31 is invalid and the output expansion address bit 1 is selected by the value of A25. The CL-PS7110 always outputs '0' on expansion address bit 25, that is, in 16-bit I/O mode, processor address bit 25 becomes PCMCIA address bit 1, and PCMCIA address bit 25 is '0', limiting the 16-bit I/O address space to 32 Mbytes.

**Table 3-8. PCMCIA Mode Bus Width**

A26	A27	Bus Width	Word Bus Conversion	PCMCIA Memory Area
0	0	8 bits	Yes	8-bit attribute memory access
1	0	16 bits	Yes	16-bit common memory access
0	1	8 bits	Yes	8-bit I/O access
1	1	16 bits	No	16-bit I/O access (see above)



**Table 3-9. Values of the Random Access Wait State Field**

Value	No. Wait states	Required Random Access Speed (ns)
00	4	250
01	3	200
10	2	150
11	1	100

**Table 3-10. Values of the Sequential Access Wait State Field**

Value	No. Wait States	Required Sequential Random Access Speed (ns)
00	3	150
01	2	120
10	1	80
11	0	40

**SQAEN** Sequential access enable. Setting this bit enables sequential accesses that are on a quad-word boundary to take advantage of faster access times from devices that support Page mode. The sequential access is faulted after four words, (to allow video refresh cycles to occur), even if the access is part of a longer sequential access.

**CLKEN** Expansion clock enable. Setting this bit enables the EXPCLK to be active during accesses to the selected expansion device. This provides a timing reference for devices that need to extend bus cycles using the EXPRDY input. Back-to-back (but not necessarily Page mode) accesses result in a continuous clock.

See [Chapter 4](#) for more detail on bus timing.

### 3.2.15 DRFPR — DRAM Refresh Period Register

The DRAM Refresh Period register is an 8-bit read/write register that enables refresh and selects the refresh period used by the DRAM controller for its periodic CAS-before-RAS refresh. The value in the DRAM refresh period register is **only** cleared by a *power on reset*, that is, the register state is maintained during a power fail or user reset.

7	60
RFSHEN	RFDIV

**RFSHEN** DRAM refresh enable. Setting this bit enables periodic refresh cycles to be generated by the CL-PS7110 at a rate set by the RFDIV field. Setting this bit also enables Self-refresh mode when the CL-PS7110 is in the standby state.

**RFDIV** This 7-bit field sets the DRAM refresh rate. The refresh period is derived from a 128-kHz clock and is given by the formula:

$$\text{Frequency (kHz)} = 128 / (\text{RFDIV} + 1), \text{ that is,} \\ \text{RFDIV} = (128 / \text{Refresh frequency (kHz)}) - 1 \quad \text{Equation 3-1}$$

The maximum refresh frequency is 64 kHz, the minimum is 1 kHz. The RFDIV field should not be programmed with '0' as this results in no refresh cycles being initiated.

### 3.2.16 INTSR — Interrupt Status Register

The Interrupt Status register is a 16-bit read-only register. This register reflects the current state of the 16 interrupt sources within the CL-PS7110. Each bit is set if the appropriate interrupt is active. The interrupt assignment is given below.

7	6	5	4	3	2	1	0
EINT3	EINT2	EINT1	CSINT	MCINT	WEINT	BLINT	EXTFIQ
15	14	13	12	11	10	9	8
SSEOTI	UMSINT	URXINT	UTXINT	TINT	RTCMI	TC2OI	TC1OI

**EXTFIQ** External fast interrupt. This interrupt is active if the NEXTFIQ input pin is forced low and is mapped to the FIQ input on the ARM710A microprocessor.

**BLINT** Battery low interrupt. This interrupt is active if no external supply is present (BATOK is high), and the battery-OK input pin BATOK is forced low. This interrupt is de-glitched with a 16-kHz clock so it only generates an interrupt if it is active for longer than 62.5 ms. It is mapped to the FIQ input on the ARM710A microprocessor and is cleared by writing to the BLEOI location.

**WEINT** Watch dog expired interrupt. This interrupt is active on a rising edge of the periodic 64-Hz tick interrupt clock if the tick interrupt is still active, that is, if a tick interrupt has not been serviced for a complete tick period. It is cleared by writing to the TEOI location.

**MCINT** Media changed interrupt. This interrupt is active after a rising edge on the MEDCHG input pin has been detected. This input is de-glitched with a 16-kHz clock and only generates an interrupt if it is active for longer than 62.5 ms. It is mapped to the FIQ input on the ARM710A microprocessor and is cleared by writing to the MCEOI location.

**CSINT** Codec sound interrupt. This interrupt is active if the codec interface is enabled and the codec data FIFO has reached half full or empty (depending on the interface direction). It is cleared by writing to the COEOI location.

**EINT1** External interrupt input 1. This interrupt is active if the NEINT1 input is active (low). It is cleared by returning NEINT1 to the passive (high) state.

<b>EINT2</b>	External interrupt input 2. This interrupt is active if the NEINT2 input is active (low). It is cleared by returning NEINT2 to the passive (high) state.
<b>EINT3</b>	External interrupt input 3. This interrupt is active if the EINT3 input is active (high) it is cleared by returning EINT3 to the passive (low) state.
<b>TC1OI</b>	TC1 under-flow interrupt. This interrupt becomes active on the <b>next</b> falling edge of the timer counter 1 clock after the timer counter has under-flowed (reached '0'). It is cleared by writing to the TC1EOI location.
<b>TC2OI</b>	TC2 under-flow interrupt. This interrupt becomes active on the <b>next</b> falling edge of the timer counter 2 clock after the timer counter has under-flowed (reached '0'). It is cleared by writing to the TC2EOI location.
<b>RTCFMI</b>	RTC compare match interrupt. This interrupt becomes active on the <b>next</b> rising edge of the 1-Hz realtime clock (one second later) after the 32-bit time written to the real-time clock match register exactly matches the current time in the RTC. It is cleared by writing to the RTCEOI location.
<b>TINT</b>	64-Hz tick interrupt. This interrupt becomes active on every rising edge of the internal 64-Hz clock signal. This 64-Hz clock is derived from the 15-stage ripple counter that divides the 32.768-kHz oscillator input down to 1 Hz for the realtime clock. This interrupt is cleared by writing to the TEOI location.
<b>UTXINT</b>	Internal UART transmit FIFO half-empty interrupt. The function of this interrupt source depends on whether the UART FIFO is enabled. If the FIFO is disabled (FIFOEN bit is clear in the UART Bit Rate and Line Control register), this interrupt is active when there is no data in the UART Tx Data Holding register, and cleared by writing to the UART Data register. If the FIFO is enabled this interrupt is active when the UART Tx FIFO is half or more empty, and is cleared by filling the FIFO to at least half full.
<b>URXINT</b>	Internal UART receive FIFO half-full interrupt. The function of this interrupt source depends on whether the UART FIFO is enabled. If the FIFO is disabled this interrupt is active when there is valid Rx data in the UART Rx Data Holding register, and is cleared by reading this data. If the FIFO is enabled this interrupt is active when the UART Rx FIFO is half or more full or if the FIFO is non empty and no more characters are received for a 3-character time-out period. It is cleared by reading all the data from the Rx FIFO.
<b>UMSINT</b>	Internal UART modem status changed interrupt. This interrupt is active if either of the two modem status lines (CTS or DSR) change state. It is cleared by writing to the UMSEOI location.
<b>SSEOTI</b>	Synchronous serial interface end-of-transfer interrupt. This interrupt is active after a complete data transfer to and from the external ADC has completed. It is cleared by reading the ADC data from the SYNCIO register.

### 3.2.17 INTMR — Interrupt Mask Register

The Interrupt Mask register is a 16-bit read/write register used to selectively enable any of the 16 interrupt sources within the CL-PS7110. The four shaded (see following table) interrupts all generate a fast interrupt request to the ARM710A microprocessor; this causes a jump to processor virtual address 0000.0001C. All other interrupts generate a standard interrupt request; this causes a jump to processor virtual address 0000.00018. See [Table 1-1 on page 14](#) for the interrupt allocation. Setting the appropriate bit in this register enables the corresponding interrupt. All bits are cleared by a *system reset*.

7	6	5	4	3	2	1	0
EINT3	EINT2	EINT1	CSINT	MCINT	WEINT	BLINT	EXTFIQ
15	14	13	12	11	10	9	8
SSEOTI	UMSINT	URXINT	UTXINT	TINT	RTCMI	TC2OI	TC1OI

### 3.2.18 LCDCON — LCD Control Register

The LCD Control register is a 32-bit read/write that controls the size of the LCD screen and the operating mode of the LCD controller operates in. Refer to [Section 1.2.10](#) for more information on video buffer mapping and the LCD controller.

31	30	29	25	24	19	18	13	12	0
GSMD	GSEN	AC prescale	Pixel prescale	Line length	Video buffer size				

**Video buffer size** The video buffer size field is a 13-bit field that sets the total number of bits  $\times$  128 (quad words) in the video display buffer. This is calculated from the formula:  
 Video buffer size = (Total bits in video buffer / 128) – 1  
 For example, for a 640  $\times$  240 LCD and 4 bits per pixel the size of the video buffer = 640  $\times$  240  $\times$  4 = 614400 bits  
 Video buffer size field = (614400 / 128) – 1 = 4799 or 0x12BF h.

**Line length** The line length field is a 6-bit field that sets the number of pixels in one complete line. This field is calculated from the formula: **Line length = (No. pixels in line / 16) – 1**  
 For example, for 640  $\times$  240 LCD Line length = (640 / 16) – 1 = 39 or 0x27 h.

### Pixel prescale

The pixel prescale field is a 6-bit field that sets the pixel rate prescale. The pixel rate is derived from a 36.864-MHz clock and is calculated from the formula:

$$\text{Pixel rate (MHz)} = 36.864 / (\text{pixel prescale} + 1)$$

The pixel rate should be chosen to give a complete screen refresh frequency of approximately 70 Hz to avoid flicker. Frequencies above 70 Hz should be avoided as they consume additional power. The pixel prescale value can be expressed in terms of the LCD size by the formula:

$$\text{Pixel prescale} = (526628 / \text{Total pixels in display}) - 1$$

The value should be rounded down to the nearest whole number. '0' is illegal and will result in no pixel clock.

For example: A 640 × 240 LCD, pixel prescale = 526628 / (640 × 240) - 1 = 2.428 (2)

This gives an actual pixel rate of 36.864E6 / 2 + 1 = 12.288 MHz

Which gives an actual refresh frequency of 12.288E6 / (640 × 240) = 80 Hz.

**NOTE:** As the CL2 low pulse time is doubled after every CL1 high pulse (see [Figure 4-7](#)), this refresh frequency is only an approximation; the accurate formula is 12.288E6 / ((640 × 240) + 120) = 79.937 Hz.

### AC prescale

The AC prescale field is a 5-bit number that sets LCD AC bias frequency. This frequency is the required AC bias frequency for a given manufacturer's LCD plate. This frequency is derived from the frequency of the line clock (CL1). The 'M' signal toggles after n+1 counts of the line clock (CL1) where n is the number programmed into the AC prescale field. This number must be chosen to match the manufacturer's recommendation (normally 13), but must not be exactly divisible by the number of lines in the display.

### GSEN

Grayscale enable bit. Setting this bit enables grayscale output to the LCD. When this bit is cleared, each bit in the video map directly corresponds to a pixel in the display.

### GSMD

Grayscale mode bit. Clearing this bit sets the controller to 2 bits per pixel (4 grayscales). Setting sets the controller to 4 bits per pixel (15 grayscales).

### 3.2.19 TC1D — Timer Counter 1 Data Register

The Timer Counter 1 Data register is a 16-bit read/write register that sets and reads data to TC1. Any value written is decremented on the next rising edge of the clock.

### 3.2.20 TC2D — Timer Counter 2 Data Register

The Timer Counter 2 Data register is a 16-bit read/write register that sets and reads data to TC2. Any value written is decremented on the next rising edge of the clock.

### 3.2.21 RTCDR — Realtime Clock Data Register

The Realtime Clock Data register is a 32-bit read/write register that sets and reads the binary time in the RTC. Any value written is incremented on the next rising edge of the 1-Hz clock. All bits in the Realtime Clock Data register are only cleared by an active NPOR.

### 3.2.22 RTCMR — Realtime Clock Match Register

The Realtime Clock Match register is a 32-bit read/write register that sets and reads the binary match time to RTC. Any value written is compared to the current binary time in the RTC, if they match it asserts the RTCMI interrupt source.

### 3.2.23 PMPCON — Pump Control Register

The DC-to-DC Converter Pump Control register is a 12-bit read/write-only register that sets and controls the variable mark space ratio drives for two DC-to-DC converters. All bits in this register are cleared by a *system reset*.

11	8 7	4 3	0
Drive 1 pump ratio	Drive 0 from mains ratio	Drive 0 from battery ratio	

**Drive 0 from battery** This 4-bit field controls the on time for the drive 0 DC-to-DC pump while the system is powered from batteries. Setting these bits to '0' disables this pump, setting these bits to '1' allows the pump to be driven in a 1:16 duty ratio, 2 in a 2:16 duty ratio, etc., up to a 15:16 duty ratio. An 8:16 duty ratio results in a square wave of 96 kHz. The NEXTPWR input is used to switch between the two on times for 'drive0'.

**Drive 0 from mains** This 4-bit field controls the on time for the drive 0 DC-to-DC pump while the system is powered from mains (the DC jack input). Setting these bits to '0' disables this pump; setting these bits to '1' allows the pump to be driven in a 1:16 duty ratio, 2 in a 2:16 duty ratio, etc., up to a 15:16 duty ratio. An 8:16 duty ratio results in a square wave of 96 kHz. The NEXTPWR input switches between the two on times for drive 0.

**Drive 1 pump ratio** This 4-bit field controls the on time for the drive 1 DC-to-DC pump. Setting these bits to '0' disables this pump, setting these bits to '1' allows the pump to be driven in a 1:16 duty ratio, 2 in a 2:16 duty ratio, etc., up to a 15:16 duty ratio. An 8:16 duty ratio results in a square wave of 96 kHz.

The state of the output drive pins is latched during power on reset, this latched value is used to determine the polarity of the drive output. The sense of the DC-to-DC converter control lines is summarized in [Table 3-11](#).

**Table 3-11. Sense of DC-to-DC Converter Control Lines**

Initial State of Drive 'n' during POR	Sense of Drive 'n'	Polarity of Bias Voltage
Low	Active high	+VE
High	Active low	-VE

### 3.2.24 CODR — Codec Interface Data Register

The CODR register is an 8-bit read/write register. Data written to or read from this register is pushed or popped onto the appropriate 16-byte FIFO buffer. Data from this buffer is then serialized and sent to or received from the codec sound device. The codec interrupt CSINT is generated repetitively at 1/8th of the byte transfer rate and the state of the FIFOs can be read in the System Flags register. The net data transfer rate to/from the codec device is 8 Kbytes per second giving an interrupt rate of 1 kHz.

### 3.2.25 UARTDR — UART Data Register

The UARTDR register is an 11-bit read and 8-bit write register for all data transfers to or from the internal UART.

Data written to this register is pushed onto the 16-byte data Tx holding FIFO if the FIFO is enabled; if not, it is stored in a 1-byte holding register. This write initiates transmission from the UART.

The UART Data Read register comprises the 8-bit data byte received from the UART together with three bits of error status. Data read from this register is popped from the 16-byte data Rx FIFO if the FIFO is enabled, if not it is read from a 1-byte buffer register containing the last byte received by the UART. Data received and error status is automatically pushed onto the Rx FIFO if it is enabled. The Rx FIFO is 10 bits wide by 16 deep.

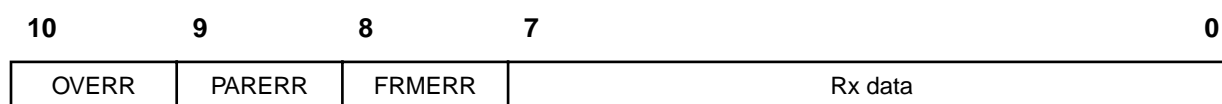

**FRMERR**            UART framing error. This bit is set if the UART detected a framing error while receiving the associated data byte. Framing errors are caused by non-matching word lengths or bit rates.

**PARERR**            UART parity error. This bit is set if the UART detected a parity error while receiving the data byte.

**OVERR**             UART overrun error. This bit is set if more data is received by the UART and the FIFO is full. The Overrun Error bit is not associated with any single character and so is not stored in the FIFO, if this bit is set, the entire contents of the FIFO is invalid and should be cleared. This error bit is cleared by reading the UARTDR register.

### 3.2.26 UBRLCR — UART Bit Rate and Line Control Register

The UART Bit Rate and Line Control register is a 19-bit read/write register. Writing to this register sets the bit rate and mode of operation for the internal UART.

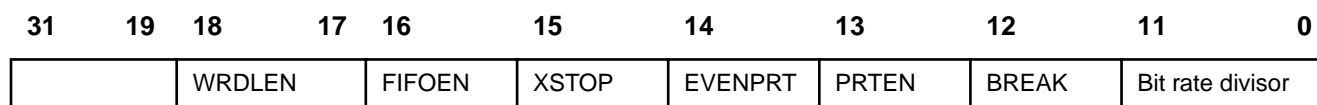

**Bit rate divisor**    This 12-bit field set the bit rate. The bit rate divider is fed by a clock frequency of 3.6864 MHz, it is then further divided internally by 16 to give the bit rate. The formula to give the divisor value for any bit rate is: **Divisor = (230400 / bit rate) - 1**. A value of '0' in this field is illegal. [Table 3-12](#) shows some example bit rates with the corresponding divisor value.

**Table 3-12. Internal UART Bit Rates**

Divisor Value	Bit Rate
1	115200
2	76800
3	57600
5	38400
11	19200
15	14400
23	9600
95	2400
191	1200
2094	110

- BREAK**                    Setting this bit drives the Tx output active (high) to generate a break.
- PRTEN**                    Parity enable bit. Setting this bit enables parity detection and generation.
- EVENPRT**                Even parity bit. Setting this bit sets parity generation and checking to even parity, clearing it sets odd parity. This bit has no effect if the PRTEN bit is clear.
- XSTOP**                    Extra stop bit. Setting this bit causes the UART to transmit two stop bits after each data byte, clearing it transmits one stop bit after each data byte.
- FIFOEN**                   Set to enable FIFO buffering of Rx and Tx data. Clear to disable the FIFO, that is, set its depth to one byte.
- WRDLEN**                 This 2-bit field selects the word length according to [Table 3-13](#).

**Table 3-13. UART Word Length**

WRDLEN	Word Length
00	5 bits
01	6 bits
10	7 bits
11	8 bits

### 3.2.27 PALLSW Least-Significant Word-LCD Palette Register

The least- and most-significant Word-LCD Palette registers make up a 64-bit read/write register, which maps the logical pixel value to a physical grayscale level. The 64-bit register is made up of 16 × 4-bit nibbles, each nibble defines the grayscale level associated with the appropriate pixel value. If the LCD controller is operating in two bits per pixel, only the lower four nibbles are valid D[15:0] in the least-significant



word), similarly one bit per pixel means only the lower two nibbles are valid D[7:0] in the least-significant word). The pixel-to-grayscale level assignments are shown in [Table 3-14](#) and [Table 3-15](#).

**Table 3-14. Least-Significant Word Palette Assignments**

31:28	27:24	23:20	19:16	15:12	11:8	7:4	3:0
Grayscale value for pixel value 7	Grayscale value for pixel value 6	Grayscale value for pixel value 5	Grayscale value for pixel value 4	Grayscale value for pixel value 3	Grayscale value for pixel value 2	Grayscale value for pixel value 1	Grayscale value for pixel value 0

**PALMSW Most-Significant Word-LCD Palette Register**

See PALLSW description in [Section 3.2.27](#).

**Table 3-15. Most-Significant Word Palette Assignments**

31:28	27:24	23:20	19:16	15:12	11:8	7:4	3:0
Grayscale value for pixel value 15	Grayscale value for pixel value 14	Grayscale value for pixel value 13	Grayscale value for pixel value 12	Grayscale value for pixel value 11	Grayscale value for pixel value 10	Grayscale value for pixel value 9	Grayscale value for pixel value 8

The actual physical color and pixel duty ratio for the grayscale values is shown in [Table 3-16](#). Note that colors 8–15 are the inverse of colors 7–0 respectively; this means that colors 7 and 8 are identical. The steps in the grayscale are nonlinear but have been chosen to give a close approximation to perceived linear grayscales. This is due to the eye being more sensitive to changes in gray level close to 50% gray.

**Table 3-16. Grayscale Value to Color Mapping**

Grayscale Value	Duty Cycle	% Pixels Lit	% Step change
0	0	0%	11.1%
1	1/9	11.1%	8.9%
2	1/5	20.0%	6.7%
3	4/15	26.7%	6.6%
4	3/9	33.3%	6.7%
5	2/5	40.0%	5.4%
6	4/9	44.4%	5.6%
7	1/2	50.0%	0.0%
8	1/2	50.0%	5.6%
9	5/9	55.6%	5.4%
10	3/5	60.0%	6.7%
11	6/9	66.7%	6.6%

**Table 3-16. Grayscale Value to Color Mapping (cont.)**

12	11/15	73.3%	6.7%
13	4/5	80.0%	8.9%
14	8/9	88.9%	11.1%
15	1	100%	—

### 3.2.28 SYNCIO Synchronous Serial Interface Data Register

SYNCIO is a 16-bit read/write register. The data written to the SYNCIO register configures the SSI, and the least-significant byte is serialized and transmitted out of the synchronous serial interface to configure an external ADC, bit D7 (the MSB) first. The transfer clock automatically starts at the programmed frequency, and a synchronization pulse is issued. The ADCIN pin is sampled on every clock edge, and the result is shifted in to the SYNCIO read register.

During data transfer the SSIBUSY bit is set high, at the end of a transfer the SSEOTI interrupt is asserted. This interrupt is cleared by reading the SYNCIO register. The data read from the SYNCIO register is the *last* sixteen bits shifted out of the ADC. The length of the data frame can be programmed by writing to the SYNCIO register, this allows many different ADCs to be accommodated. [Table 3-17](#) defines the bits in the SYNCIO register.

**Table 3-17. Bits in SYNCIO Write Register**

15	24	14	16	13	16	12	8	7	0
Reserved	TXFRMEN	SMCKEN	Frame length				ADC Configuration byte		

ADC configuration	8-bit configuration data to be sent to the ADC.
Frame length	The 5-bit Frame length field is the total number of shift clocks required to complete a data transfer. For many ADCs this is 25, 8 for configuration byte + 1 null bit + 16 bits.
SMCKEN	Setting this bit enables a free-running sample clock at the programmed ADC clock frequency to be output on the SMPLCK pin.
TXFRMEN	Setting this bit causes an ADC data transfer to be initiated; the value in the ADC configuration field is shifted out to the ADC, and depending on the frame length programmed, a number of bits is captured from the ADC. If the SYNCIO register is written to with the TXFRMEN bit low, no ADC transfer occurs, but the Frame length and SMCKEN bits are affected.

### 3.2.29 STFCLR — Clear All Start Up Reason Flags Location

A write to this location clears all the start-up reason flags in the System Flags Status register (SYSFLG).

### 3.2.30 BLEOI — Battery Low End of Interrupt

A write to this location clears the interrupt generated by a low battery (falling BATOK with NEXTPOWER high).

### **3.2.31 MCEOI — Media Changed End of Interrupt**

A write to this location clears the interrupt generated by a rising edge of the MEDCHG input pin.

### **3.2.32 TEOI — Tick End of Interrupt Location**

A write to this location clears the current pending tick interrupt and watchdog interrupt.

### **3.2.33 TC1EOI TC1 — End of Interrupt Location**

A write to this location clears the under-flow interrupt generated by TC1.

### **3.2.34 TC2EOI TC2 — End Of Interrupt Location**

A write to this location clears the under-flow interrupt generated by TC2.

### **3.2.35 RTCEOI — RTC Match End Of Interrupt**

A write to this location clears the RTC match interrupt.

### **3.2.36 UMSEOI — UART Modem Status Changed End of Interrupt**

A write to this location clears the modem status changed interrupt.

### **3.2.37 COEOI — Codec End of Interrupt Location**

A write to this location clears the sound interrupt (CSINT).

### **3.2.38 HALT — Enter Idle State Location**

A write to this location places the system into the *idle* state by halting the clock to the processor until an interrupt is generated. A write to this location while there is an active interrupt has no effect. If the *idle* state is entered with no interrupts enabled, there is no mechanism for exiting the state except for a system reset.

### **3.2.39 STDBY — Enter Standby State Location**

A write to this location places the system into the *standby* state by halting the main oscillator. It automatically switches the DRAMs to self-refresh if the RFSHEN bit is set in the DRAM Refresh Period register. All transitions to the *standby* state are synchronized with DRAM cycles. A write to this location while there is an active interrupt has no effect.

## 4. ELECTRICAL SPECIFICATIONS

### 4.1 Absolute Maximum Ratings

DC supply voltage	-0.5 volts to +6 volts
DC input/output voltage	-0.5 volts to $V_{DD} + 0.5$ volts
DC input current	$\pm 20$ mA
Storage temperature	-40°C to +125°C
Lead temperature	+300°C

### 4.2 Recommended Operating Conditions

DC supply voltage	+3.0 volts to +3.6 volts
DC input/output voltage	0 to $V_{DD}$
DC input current	$\pm 15$ mA
Operating temperature	0°C to +70°C

### 4.3 DC Characteristics

All characteristics are specified at  $V_{DD} = 3.0$  to  $3.6$  volts and  $V_{SS} = 0$  volts over an operating temperature of  $0^{\circ}\text{C}$  to  $+70^{\circ}\text{C}$ .

**Table 4-1. DC Characteristics**

Symbol	Parameter	MIN	MAX	Units	Conditions
$V_{IH}$	CMOS input high voltage	$0.7 \times V_{DD}$	$V_{DD} + 0.3$	V	
$V_{IL}$	CMOS input low voltage	-0.3	$0.2 \times V_{DD}$	V	
$V_{T+}$	Schmitt trigger positive going threshold	1.52	2.26	V	
$V_{T-}$	Schmitt trigger negative going threshold	0.72	1.29	V	
$V_{HST}$	Schmitt trigger hysteresis	0.64	1.13	V	$V_{IL}$ to $V_{IH}$
$V_{OH}$	CMOS output high voltage Output drive 1 and 2 Output drive 3 and 4	$V_{DD} - 0.3$ $V_{DD} - 1.0$ $V_{DD} - 1.0$		V V V	$I_{OH} = 0.8$ mA $I_{OH} = 3$ mA $I_{OH} = 12$ mA
$V_{OL}$	CMOS output low voltage Output drive 1 and 2 Output drive 3 and 4		0.1 0.5 0.5	V V V	$I_{OL} = -0.8$ mA $I_{OL} = -3$ mA $I_{OL} = -12$ mA
$I_{IN}$	Input leakage current	-10	+10	$\mu\text{A}$	$V_{IN} = V_{DD}$ or GND
$I_{OZ}$	Output tristate leakage current <sup>a</sup>	-10	+10	$\mu\text{A}$	$V_{OUT} = V_{DD}$ or GND
$C_{IN}$	Input capacitance		5	pF	
$C_{OUT}$	Output capacitance		5	pF	
$C_{I/O}$	Transceiver capacitance		5	pF	
$I_{DD_{startup}}$	Startup current consumption		50	$\mu\text{A}$	Initial 100 ms from power up, 32-kHz oscillator not stable, POR signal at $V_{IL}$ , all other I/O static, $V_{IH} = V_{DD} \pm 0.1$ V, $V_{IL} = \text{GND} \pm 0.1$ V
$I_{DD_{standby}}$	Standby current consumption		20	$\mu\text{A}$	Just 32-kHz oscillator running, all other I/O static, $V_{IH} = V_{DD} \pm 0.1$ V, $V_{IL} = \text{GND} \pm 0.1$ V
$I_{DD_{idle}}$	Idle current consumption		5	mA	Both oscillators running, CPU static, LCD refresh active, $V_{IH} = V_{DD} \pm 0.1$ V, $V_{IL} = \text{GND} \pm 0.1$ V
$I_{DD_{operating}}$	Operating current consumption		50	mA	All system active, running typical program
$V_{DD_{standby}}$	Standby supply voltage	2.2		V	Minimum standby voltage for state retention and RTC operation only

<sup>a</sup> Assumes buffer has no pull-up or pull-down resistors.

#### 4.4 AC Characteristics

All characteristics are specified at  $V_{DD} = 3.0$  to  $3.6$  volts and  $V_{SS} = 0$  volts over an operating temperature of  $0^{\circ}\text{C}$  to  $+70^{\circ}\text{C}$ . Parameters marked with an asterisk (\*) are not fully tested.

**Table 4-2. AC Characteristics**

Symbol	Parameter	MIN	MAX	Units
$t_1$	Falling CS to data bus High-Z	0*	25*	ns
$t_2$	Address change to valid write data	0	35	ns
$t_3$	DATA in to falling EXPCLK setup time	18	–	ns
$t_4$	DATA in to falling EXPCLK hold time	0	–	ns
$t_5$	EXPRDY to falling EXPCLK setup time	18	–	ns
$t_6$	Falling EXPCLK to EXPRDY hold time	0	50	ns
$t_7$	Rising NMWE to data invalid hold time	5	–	ns
$t_8$	Sequential data valid to falling NMWE setup time	–10	10	ns
$t_9$	Row address to falling NRAS setup time	5	–	ns
$t_{10}$	Falling NRAS to row address hold time	25	–	ns
$t_{11}$	Column address to falling NCAS setup time	2	–	ns
$t_{12}$	Falling NCAS to column address hold time	25	–	ns
$t_{13}$	Write data valid to falling NCAS setup time	2	–	ns
$t_{14}$	Write data valid from falling NCAS hold time	50	–	ns
$t_{15}$	LCD CL2 low time	80	3,475	ns
$t_{16}$	LCD CL2 high time	80	3,475	ns
$t_{17}$	LCD Rising CL2 to rising CL1 delay	0	25	ns
$t_{18}$	LCD Falling CL1 to rising CL2	80	3,475	ns
$t_{19}$	LCD CL1 high time	80	3,475	ns
$t_{20}$	LCD Falling CL1 to falling CL2	200	6,950	ns
$t_{21}$	LCD Falling CL1 to FRM toggle	300	10,425	ns
$t_{22}$	LCD Falling CL1 to M toggle	–10	20	ns
$t_{23}$	LCD Rising CL2 to display data change	–10	20	ns
$t_{24}$	Falling EXPCLK to address valid	–	30	ns
$t_{25}$	Initial data valid to falling NMWE setup time	5	–	ns
$t_{\text{EXTRD}}$	Zero-wait-state memory read access time	70	–	ns
$t_{\text{EXWR}}$	Zero-wait-state memory write access time	70	–	ns
$t_{\text{RC}}$	DRAM cycle time	150	–	ns

**Table 4-2. AC Characteristics (cont.)**

$t_{RAC}$	Access time from RAS	70	–	ns
$t_{RP}$	RAS precharge time	70	–	ns
$t_{CAS}$	CAS pulse width	20	–	ns
$t_{CP}$	CAS precharge in Page mode	12	–	ns
$t_{PC}$	Page mode cycle time	45	–	ns
$t_{CSR}$	CAS set-up time for auto refresh	15	–	ns
$t_{RAS}$	RAS pulse width	80 *	–	ns

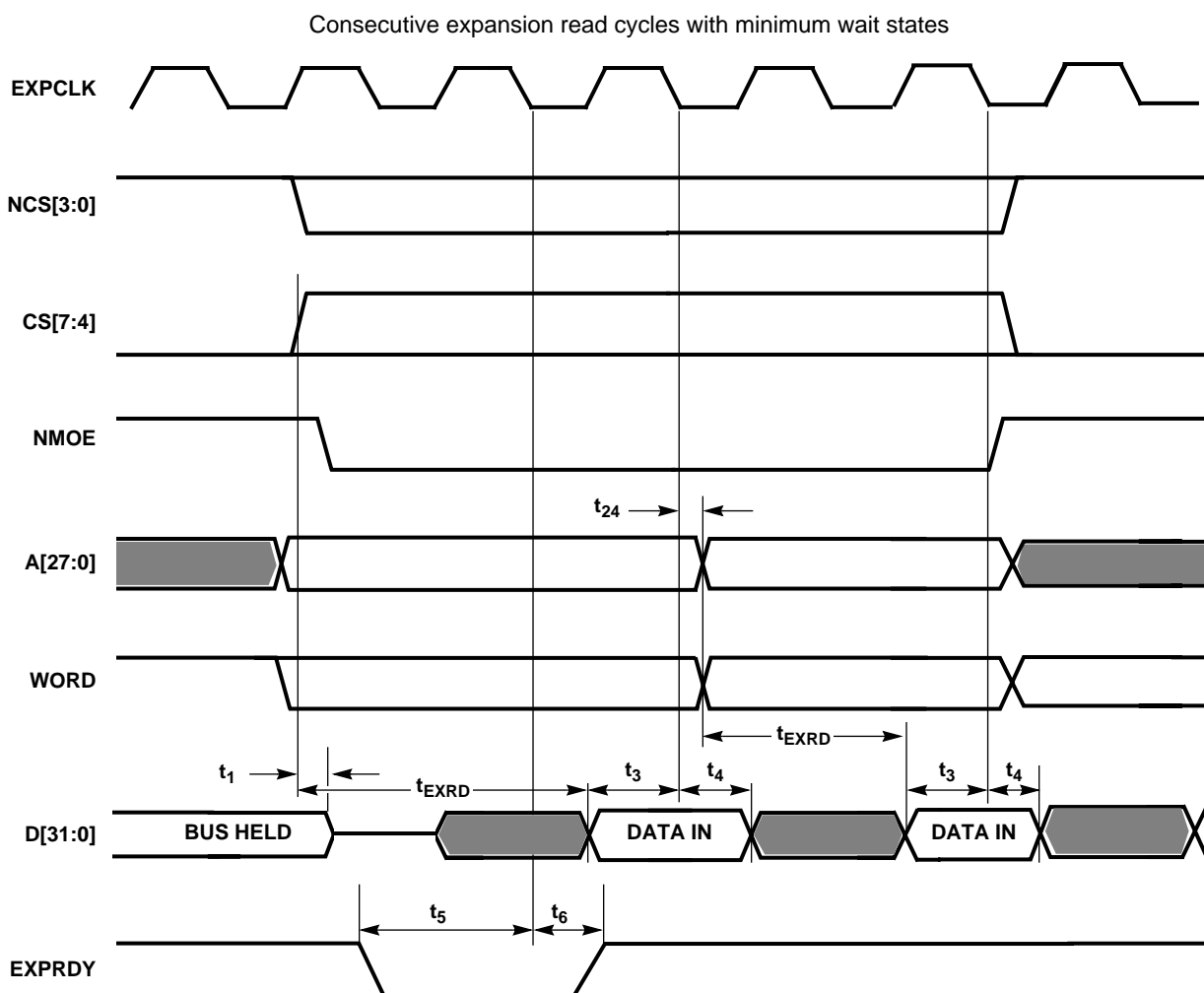

**Figure 4-1. Expansion and ROM Read Timing**

**NOTES:**

- 1)  $t_{EXRD} = 80$  ns for minimum wait states and a main oscillator frequency of 18.432 MHz. This time can be

extended by integer multiples of the clock period (54 ns), by either driving EXPRDY low and or by programming a number of wait states. EXPRDY is sampled on the falling edge of EXPCLK before the data transfer, if low at this point the transfer is delayed by one clock period where EXPRDY is sampled again. EXPCLK need not be referenced when driving EXPRDY but is shown for clarity.

- 2) Consecutive reads with sequential access enabled are identical except that the sequential access wait state field is used to determine the number of wait states.

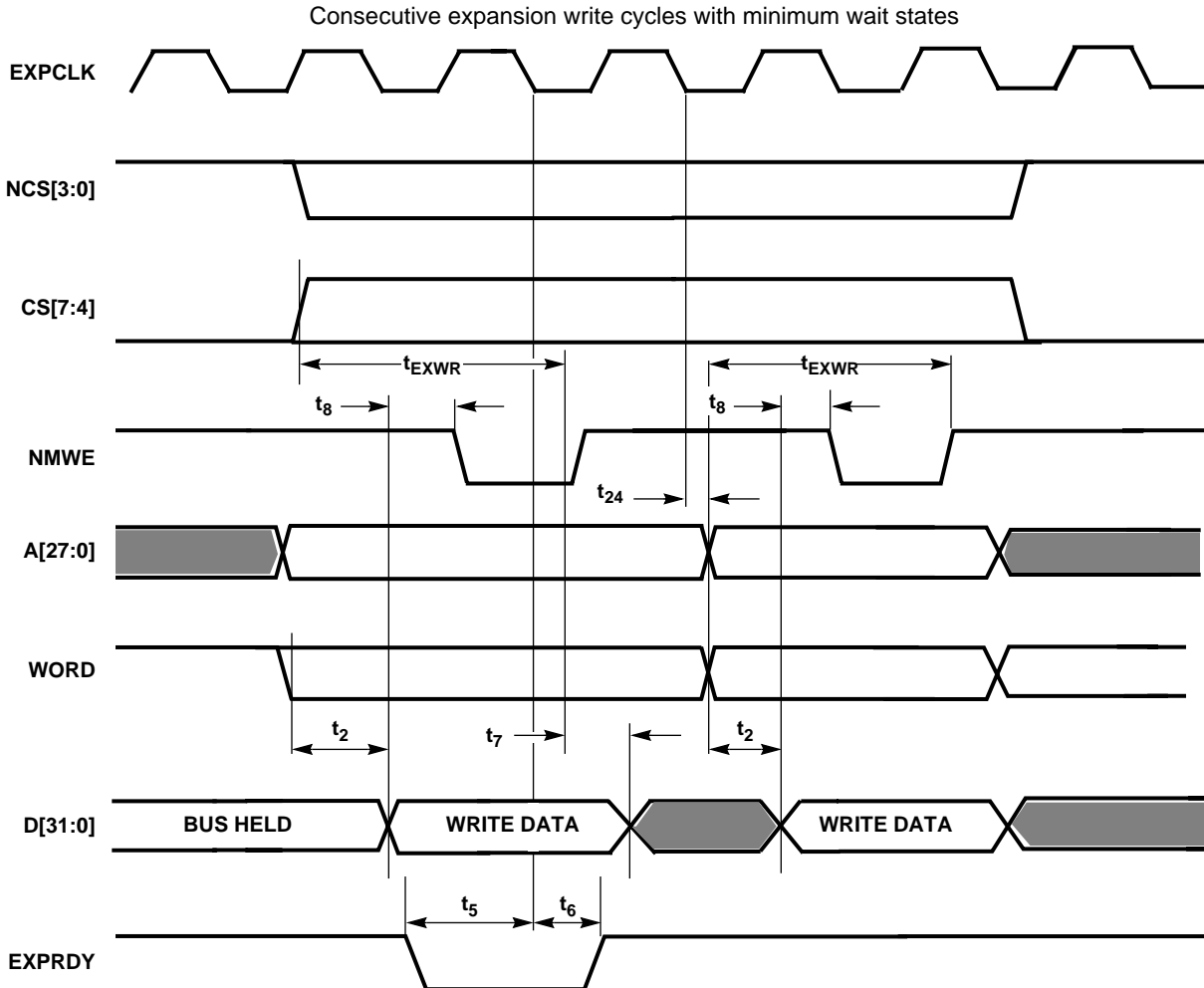

**Figure 4-2. Expansion and ROM Write Timing**

**NOTES:**

- 1)  $t_{EXWR}$  = 80 ns maximum for zero wait states. This time can be extended by integer multiples of the clock period (54 ns), by either driving EXPRDY low and or by programming a number of wait states. EXPRDY is sampled on the falling edge of EXPCLK before the data transfer, if low at this point the transfer is delayed by one clock period where EXPRDY is sampled again. EXPCLK need not be referenced when driving EXPRDY but is shown for clarity.
- 2) Consecutive writes with sequential access enabled are identical except that the sequential access wait state field is used to determine the number of wait states.
- 3) Zero wait states for sequential writes is not supported, one state automatically is added.



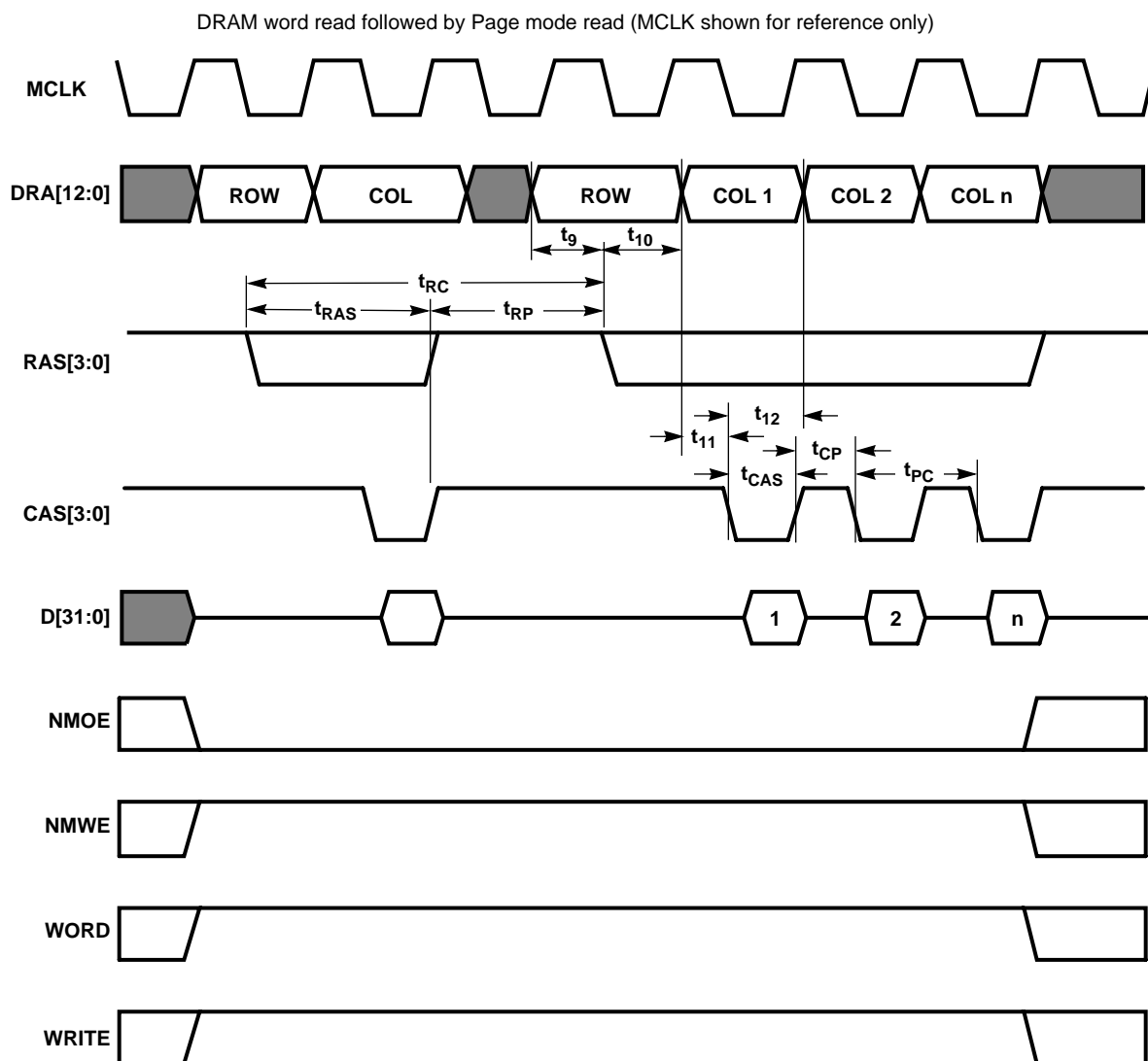
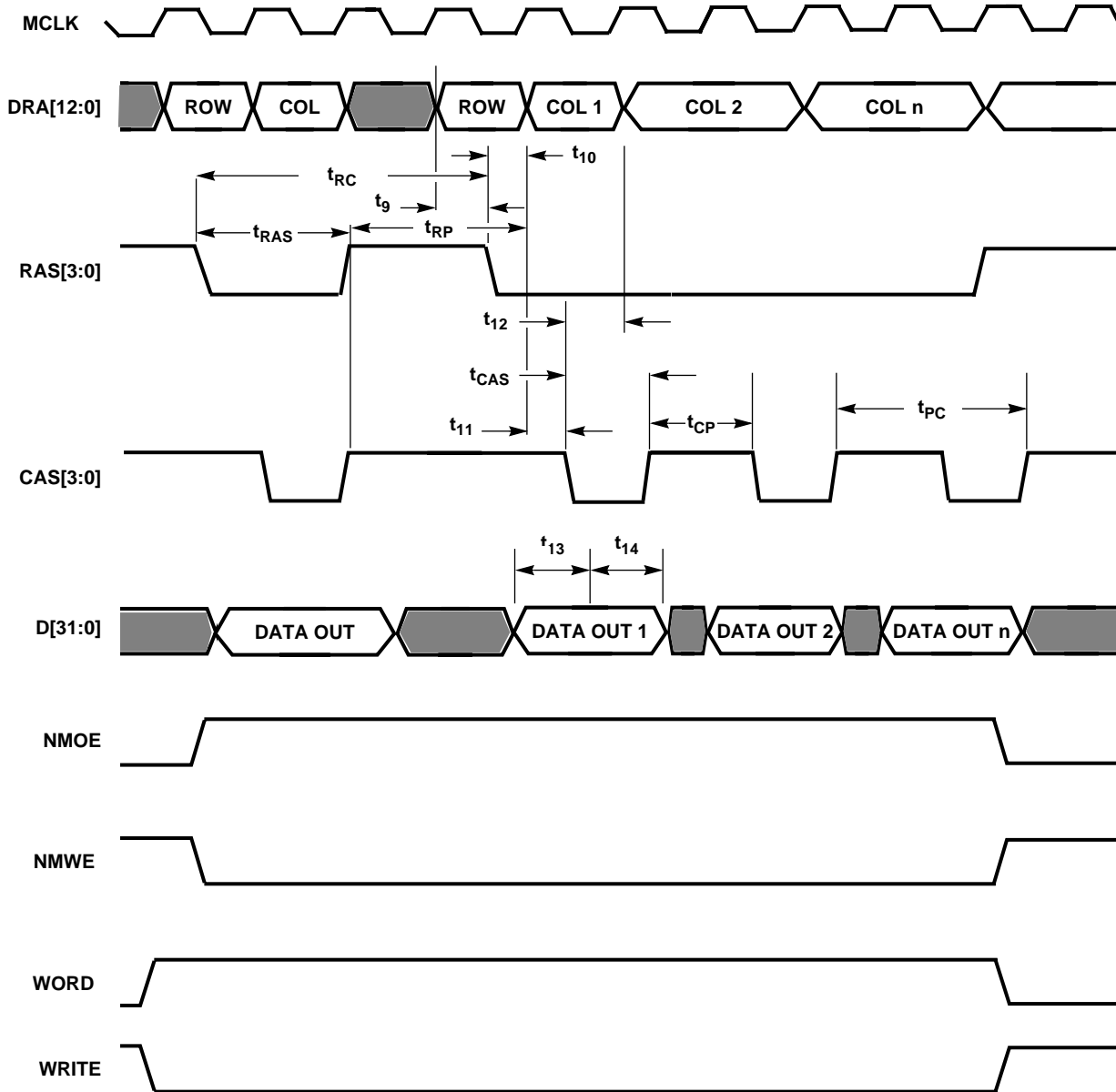

Figure 4-3. DRAM Read Cycles

NOTES:

- 1)  $t_{RC}$  (read cycle time) = 160 ns maximum
- 2)  $t_{RAC}$  (access time from RAS) = 80 ns maximum
- 3)  $t_{RP}$  (RAS precharge time) = 80 ns maximum
- 4)  $t_{CAS}$  (CAS pulse width) = 25 ns maximum
- 5)  $t_{CP}$  (CAS precharge in Page mode) = 25 ns maximum
- 6)  $t_{PC}$  (Page mode cycle time) = 50 ns minimum at maximum
- 7) Word reads shown, for byte reads only one of CAS[3:0] is active, CAS0 for byte 0, etc.

WORD write followed by sequential word write to DRAM (MCLK shown for reference only)

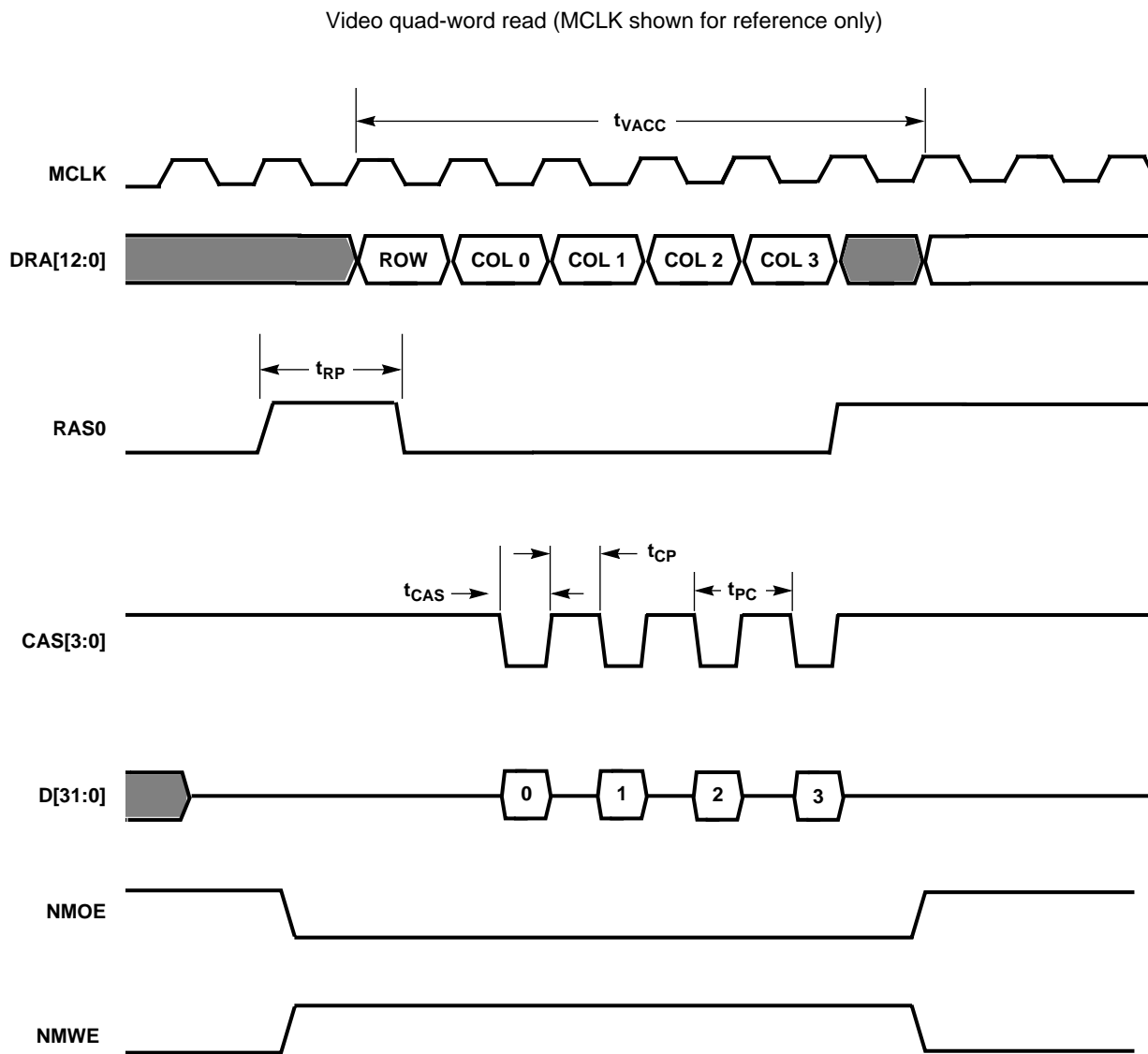

**Figure 4-4. DRAM Write Cycles**

**NOTES:**

- 1)  $t_{RC}$  (Write cycle time) = 160 ns minimum at MCLK = 18.432 MHz
- 2)  $t_{RAC}$  (Write access time from RAS) = 80 ns minimum at MCLK = 18.432 MHz
- 3)  $t_{RP}$  (RAS precharge time) = 80 ns minimum at MCLK = 18.432 MHz

- 4)  $t_{CAS}$  (CAS pulse width) = 25 ns minimum at MCLK = 18.432 MHz
- 5)  $t_{CP}$  (CAS precharge in Page mode) = 80 ns minimum at MCLK = 18.432 MHz
- 6)  $t_{PC}$  (Page mode cycle time) = 100 ns minimum at MCLK = 18.432 MHz
- 7) Word writes shown, for byte writes only one of CAS[3:0] is active, CAS0 for byte 0, etc.

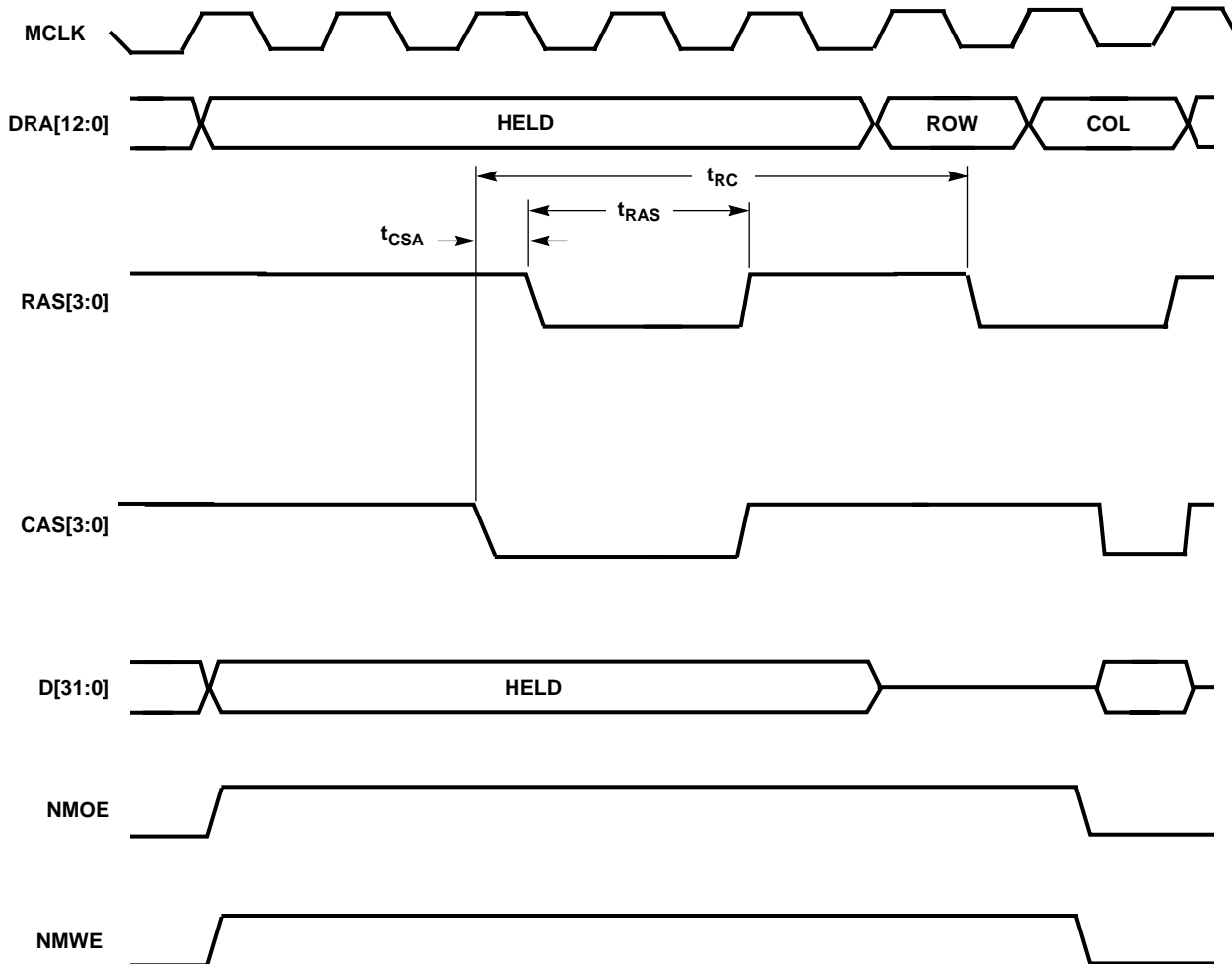

**Figure 4-5. Video Quad Word Read**

**NOTES:**

- 1) Timings are the same as Page mode word reads.
- 2)  $t_{VACC}$  (video access cycle time) = 326 ns at MCLK = 18.432 MHz

DRAM CAS-before-RAS refresh cycle (MCLK shown for reference only)

**Figure 4-6. DRAM CAS-Before-RAS Refresh Cycle**
**NOTES:**

- 1)  $t_{CSA}$  (CAS set-up time) = 25 ns minimum at MCLK = 18.432 MHz
- 2)  $t_{RAS}$  (RAS pulse width) = 80 ns minimum at MCLK = 18.432 MHz
- 3)  $t_{RC}$  (cycle time) = 160 ns minimum at MCLK = 18.432 MHz
- 4) When DRAMs are placed in self-refresh (entering standby) the same timings apply, but  $t_{RAS}$  is extended indefinitely.

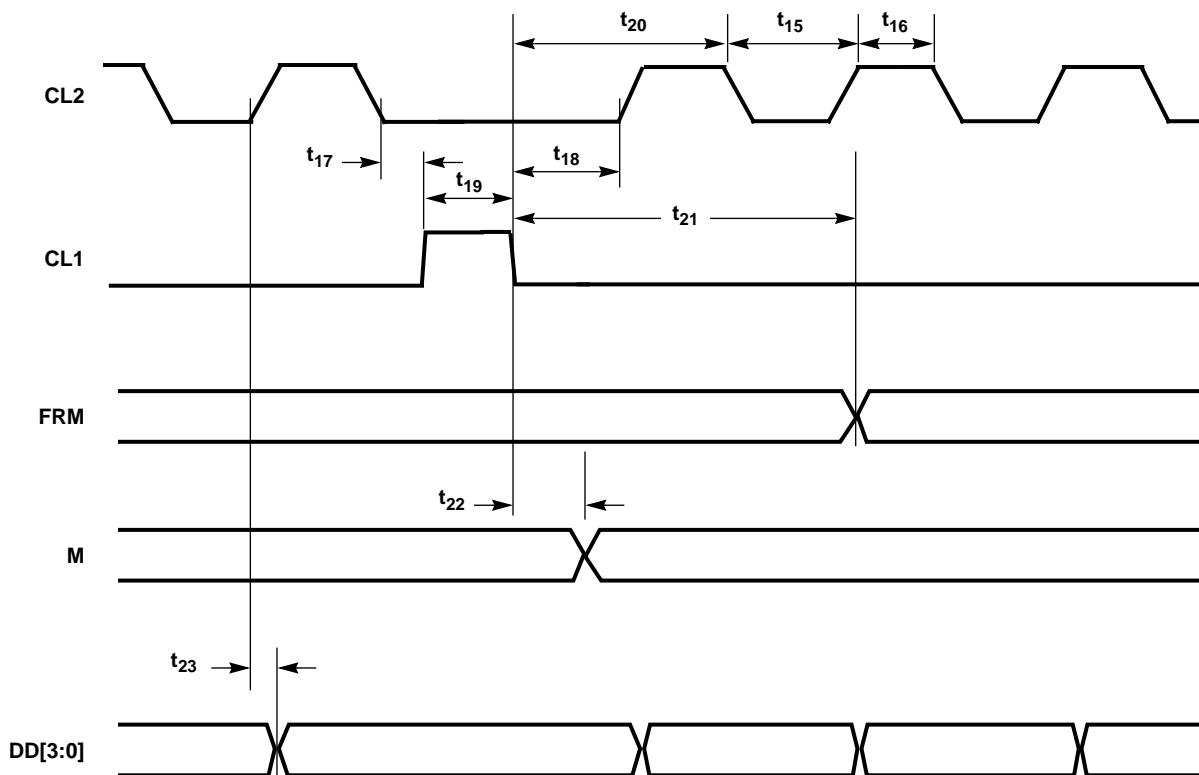

Figure 4-7. LCD Controller Timing

NOTES:

- 1) This diagram shows the end of a line.
- 2) If FRM is high during the CL1 pulse, this marks the first line in the display.
- 3) CL2 low time is doubled during the CL1 high pulse.

#### 4.5 I/O Buffer Characteristics

All I/O buffers on the CL-PS7110 are CMOS threshold input bidirectional buffers except the oscillator and power pads. Notional input signals only enable the output buffer during Pin Test mode. All output buffers are disabled during System Test (High-Z) mode. All buffers have a standard CMOS threshold input stage apart from the Schmitt inputs and CMOS, slew-rate-controlled output stages to reduce system noise. [Table 4-3](#) defines the I/O buffer output characteristics.

**Table 4-3. I/O Buffer Output Characteristics**

Buffer Type	Drive Current	Propagation Delay (MAX)	Rise Time (MAX)	Fall Time (MAX)	Load
I/O strength 1	± 3 mA	15 ns	18 ns	15 ns	50 pF
I/O strength 2	± 3 mA	15 ns	15 ns	15 ns	50 pF
I/O strength 3	± 12 mA	12 ns	15 ns	13 ns	50 pF
I/O strength 4	± 12 mA	12 ns	180 ns	80 ns	1000 pF

**NOTE:**

- 1) All propagation delays are specified at 50%  $V_{DD}$  to 50%  $V_{DD}$ ; all rise times are specified as 10%  $V_{DD}$  to 90%  $V_{DD}$ , and all fall times are specified as 90%  $V_{DD}$  to 10%  $V_{DD}$ .
- 2) Pull-up current = 50  $\mu$ A typical at  $V_{DD}$  = 3.3 volts.

#### 4.6 Test Modes

The CL-PS7110 supports a number of hardware-activated test modes; these are activated by the pin combinations shown in [Table 4-4](#). All latched signals will only alter test modes while NPOR is low, and their state is latched on the rising edge of NPOR. This allows these signals be used normally during various test modes; for example, the NURESET input can be used normally when the device is set into Functional Test (EPB) mode.

**Table 4-4. CL-PS7110 Hardware Test Modes**

Test Mode	Latched MEDCHG	Latched PE0	Latched NURESET	NTEST0	NTEST1
Normal operation (32-bit boot)	0	0	X	1	1
Normal operation (8-bit boot)	0	1	X	1	1
Alternative test ROM boot	1	X	X	1	1
Oscillator/PLL bypass	X	X	X	1	0
Functional Test (EPB)	X	X	1	0	1
Oscillator/PLL Test	X	X	0	0	1
Pin Test	X	X	1	0	0
System Test (all High-Z)	X	X	0	0	0

Within each test mode a selection of pins are used as multiplexed outputs or inputs to provide/monitor the test signals unique to that mode.

#### 4.6.1 Oscillator and PLL Bypass Mode

This mode is selected by NTEST0 = 1, NTEST1 = 0.

In this mode all the internal oscillators and PLL are disabled and the appropriate crystal oscillator pins become the direct external oscillator inputs bypassing the oscillator and PLL. MOSCIN must be driven by a 36.864-MHz clock source and RTCOUT by a 32.768-kHz source. In addition the OSCEN (oscillator enable) signal is multiplexed out on Port C bit 0 to control the external oscillator. It is driven logic to level low to disable the oscillator. The functionality of the CL-PS7110 is not affected in any other way during this test mode.

#### 4.6.2 Functional (EPB) Test Mode

This mode is selected by NTEST0 = 0, NTEST1 = 1, Latched NURESET = 1

Functional EPB (embedded peripheral bus) Test mode is used for the running test patterns, both through the EPB external test interface and for any other patterns. It is for testing individual peripherals and the ARM710A microprocessor. The PLL is automatically bypassed in this mode. In this mode various pins are used as control inputs or outputs; these are listed in [Table 4-5](#).

**Table 4-5. EPB Test Mode Signal Assignment**

Signal	I/O	Pin	Function
TSTA	I	PA0	EPB test control A
TSTB	I	PA1	EPB test control B
TSTSTART	I	PA2	Fast start speed up RTC divider chain
TSTDIRCLK	I	PA3	Insertion point for EPB test clock
TSTVCOUNT	I	PA4	Video Address counter increments faster
TACK	O	word	EPB test acknowledge output

#### 4.6.3 Oscillator and PLL Test Mode

This mode is selected by NTEST0 = 0, NTEST1 = 1, Latched NURESET = 0

This test mode enables the main oscillator and output various buffered clock and test signals derived from the main oscillator, PLL, and 32-kHz oscillator. All internal logic in the CL-PS7110 is static and isolated from the oscillators with the exception of the 6-bit ripple counter used to generate 576-kHz and the real-time clock divide chain. Port A is used to drive the inputs of the PLL directly and the various clock and PLL outputs are monitored on the COL pins. [Table 4-6](#) defines the CL-PS7110 signal pins used in this test mode.

**Table 4-6. Oscillator and PLL Test Mode Signals**

Signal	I/O	Pin	Function
TSEL <sup>a</sup>	I	PA5	PLL test select
XTALON <sup>a</sup>	I	PA4	Enable to oscillator circuit
PLLON <sup>a</sup>	I	PA3	Enable to PLL circuit
DN0	I	PA2	Selects other frequencies from PLL with DN0
DN1 <sup>a</sup>	I	PA1	Selects other frequencies from PLL with DN1
PLLBP	I	PA0	Bypasses PLL
RTCCLK	O	COL0	Output of RTC oscillator
CLK1	O	COL1	1-Hz clock from RTC divide chain
OSC36	O	COL2	36-MHz PLL main output
CLK576K	O	COL4	576 kHz divided-down as above
VTEST	O	COL5	Analog output of VCO loop filter
VREF	O	COL6	VCO output for test

<sup>a</sup> These inputs are INVERTED before being passed to the PLL to ensure that the default state of the port (all '0') maps onto the correct default state of the PLL (TSEL = 1, XTALON = 1, PLLON = 1, D0 = 0, D1 = 1, PLLBP = 0). This state produces the correct frequencies as shown in [Table 4-6](#). Any other combinations are for testing the oscillator and PLL and should not be used in the circuit.

#### 4.6.4 Pin Test Mode

This mode is selected by NTEST0 = 0, NTEST1 = 0, Latched NURESET = 1.

This test mode allows a simple ICT tester to check if all pins on the CL-PS7110 are correctly soldered to the PCB. This mode does this by back-driving each pin in turn, and checking the response on one designated pin (the COL7 pin).

A parity bit is generated and output on the COL7 pin; this parity bit is the XOR of the input from every CL-PS7110 signal pin except for the two test inputs. The input pad of each signal is fed into this XOR gate regardless of signal type. Externally driving (back-driving) any signal pin from its reset state causes a transition of the COL7 pin. [Table 4-6](#) defines the rest state for all CL-PS7110 output pins. As Pin Test mode is entered, the states of all CL-PS7110 inputs are latched, and forced back out on the pins. Thus ALL pins (except the two test pins) are configured as outputs in this mode. This ensures only a 'good' solder joint passes the pin test. When not in Pin Test mode, the XOR chain is disabled and cannot toggle to save power.

It is essential in Pin Test mode that the NURESET pin is kept in the default (HIGH) state except when it is being tested itself. This ensures that NPOR can be safely included in the pin test chain without affecting the test mode.



#### 4.6.5 High-Z (System) Test Mode

This mode selected by NTEST0 = 0, NTEST1 = 0, Latched NURESET = 0.

This test mode asynchronously disables all output buffers on the CL-PS7110; this has the effect of removing the CL-PS7110 from the PCB so that other devices on the PCB can be tested. The internal state of the CL-PS7110 is not altered directly by this test mode.

#### 4.6.6 Test ROM Mode

This mode is entered by holding the MEDCHG input high during the transition from low to high of the NPOR input pin. If Test ROM mode is enabled the processor boots from an alternative 8-bit test ROM. The effect of this test mode is to reverse the decoding for all expansion selects. [Table 4-7](#) shows this decoding. In addition the sense of bit 1 in the Memory Configuration register is reversed so that 00 = 8-bit access, [Table 4-7](#) lists the chip select address ranges, and [Table 4-8](#), the bus width field combinations during Test ROM mode. This has the effect of making the boot ROM an 8-bit device connected to CS7.

**Table 4-7. Chip Select Address Ranges During Test ROM Mode**

Address Range	Expansion Chip Select in Test ROM Mode
0000.0000–0FFF.FFFF	CS7
1000.0000–1FFF.FFFF	CS6
2000.0000–2FFF.FFFF	CS5
3000.0000–3FFF.FFFF	CS4
4000.0000–4FFF.FFFF	NCS3
5000.0000–5FFF.FFFF	NCS2
6000.0000–6FFF.FFFF	NCS1
7000.0000–7FFF.FFFF	NCS0

**Table 4-8. Expansion and ROM Interface Bus Width During Test ROM Mode**

Bus Width Field in ROM Test Mode	Expansion Transfer Mode
00	8-bit-wide bus access
01	PCMCIA mode
10	32-bit-wide bus access
11	16-bit-wide bus access

#### 4.6.7 Software-Selectable Test Functionality

When bit 11 of the SYSCON register is set HIGH, all internal EPB accesses are output on the main address and data buses as though they were external accesses to the address space addressed by CS6. Hence CS6 handles a dual role: It is active as the strobe for internal accesses and for any accesses to the standard address range for CS6. Additionally in this mode, the following internal signals are multiplexed out of the device on port pins:

Signal	I/O	Pin	Function
NIRQ	O	PE1	NIRQ interrupt to CPU
NFIQ	O	PE2	NFIQ interrupt to CPU

**NOTE:** Port E defaults to input so PE1 and PE2 has to be programmed to output mode to observe NIRQ and NFIQ on these signals.

## 5. PACKAGE SPECIFICATIONS

### 5.1 208-Pin VQFP Package Outline Drawing

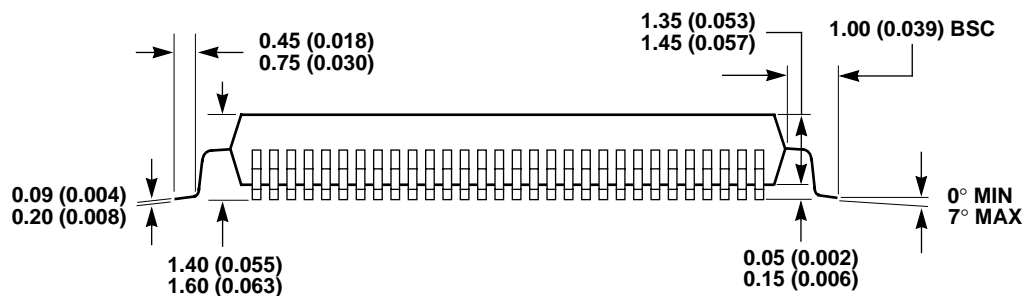
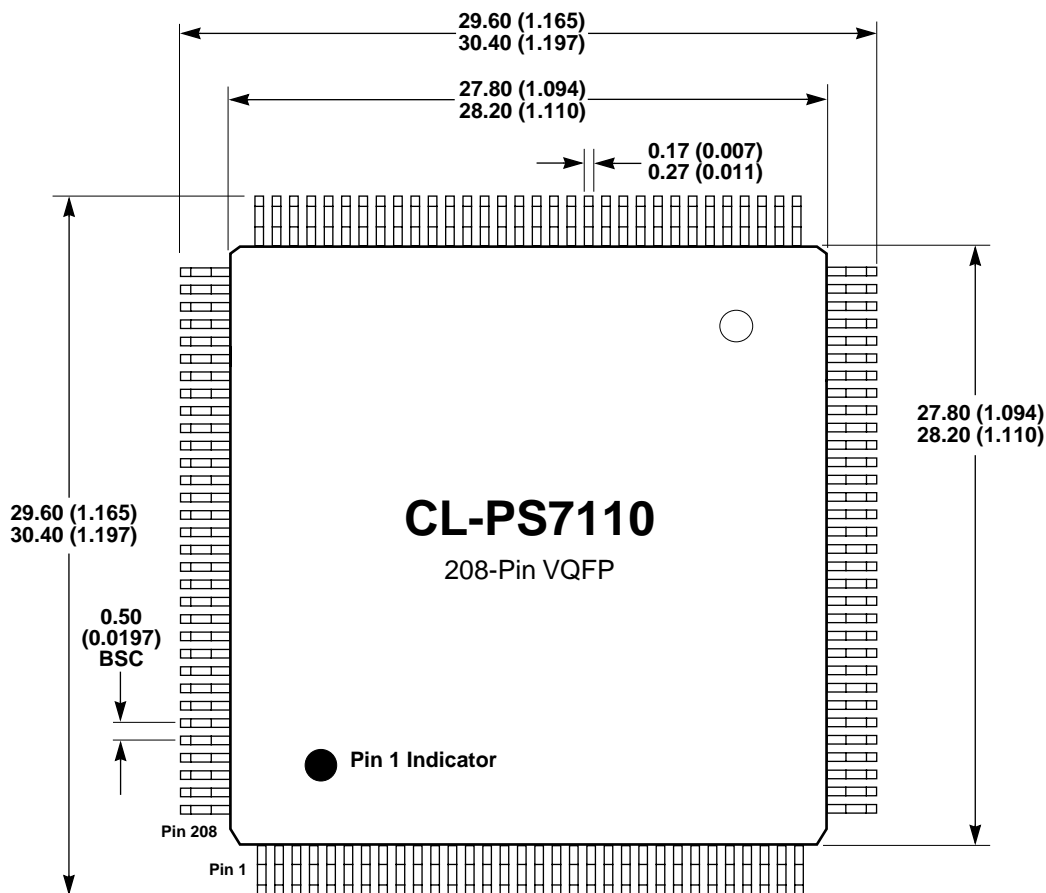

#### NOTES:

- 1) Dimensions are in millimeters (inches), and controlling dimension is millimeter.
- 2) Drawing above does not reflect exact package pin count.
- 3) Before beginning any new design with this device, please contact Cirrus Logic for the latest package information.

## 6. ORDERING INFORMATION

The order number for the device is:

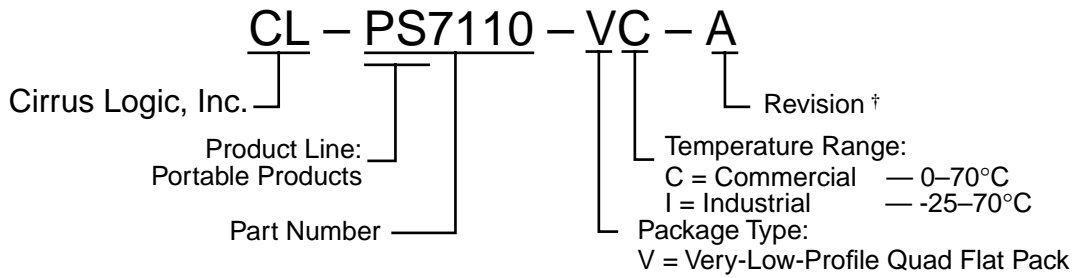

† Contact Cirrus Logic for up-to-date information on revisions.

## BIT INDEX

### Numerics

64-Hz tick interrupt (TINT) 51

### A

AC prescale 53

### B

Battery low interrupt (BLINT) 50

Bit rate divisor 55

Bit to drive buzzer (BZTOG) 44

BOOT8BIT 47

BREAK 56

Buzzer Drive (BZMOD) 44

### C

Clear to send (CTS) 46

Codec interface enable Rx (CDENRX) 44

Codec interface enable Tx (CDETX) 44

Codec Rx FIFO empty (CRXFE) 47

Codec sound interrupt (CSINT) 50

Codec Tx FIFO full (CTXFF) 47

Cold start flag (CLDFLG) 46

### D

Data carrier detect (DCD) 46

Data set ready (DSR) 46

Debug enable (DBGEN) 44

Display ID nibble (DID) 46

DRAM refresh enable (RFSHEN) 49

DRAM refresh rate (RFDIV) 50

Drive 0 from battery 54

Drive 0 from mains 54

Drive 1 pump ratio 54

### E

Even parity (EVENPRT) 56

Expansion clock enable (CLKEN) 49

External expansion clock enable (EXCKEN) 44

External fast interrupt (EXTFIQ) 50

External interrupt input 1 (EINT1) 50

External interrupt input 2 (EINT2) 51

External interrupt input 3 (EINT3) 51

Extra stop (XSTOP) 56

### F

FIFO buffering of Rx and Tx data enable (FIFOEN) 56

### G

Grayscale enable (GSEN) 53

Grayscale mode (GSMD) 53

### H

HP SIR protocol encoding enable (SIREN) 44

### I

Internal UART enable (UARTEN) 44

Internal UART modem status changed interrupt (UMSINT) 51

Internal UART receive FIFO half-full interrupt (URXINT) 51

Internal UART transmit FIFO half-empty interrupt (UTXINT) 51

Inverted NDCDET enable (DCDET) 46

IrDA Tx mode (IRTXM) 45

### K

Keyboard Scan 43

### L

LCD enable bit (LCDEN) 44

Line length 52

### M

Media changed direct read (MCDR) 46

Media changed interrupt (MCINT) 50

Microwire/SPI peripheral clock speed select (ADCKSEL) 45

### N

New battery flag (NBFLG) 46

### P

Parity enable (PRTEN) 56

Pixel prescale 53

Power fail flag (PFFLG) 46

### R

Reset flag (RSTFLG) 46

RTC compare match interrupt (RTCMI) 51

RTC divisor output (RTCDIV) 46

### S

Sequential access enable (SQAEN) 49

Synchronous serial interface end-of-transfer interrupt  
(SSEOTI) 51

**T**

TC1 under-flow interrupt (TC1OI) 51  
TC2 under-flow interrupt (TC2OI) 51  
Timer Counter 1 (TC1) 44  
Timer Counter 1 clock source (TC1S) 44  
Timer Counter 2 (TC2M) 44  
Timer Counter 2 clock source (TC2S) 44

**U**

UART framing error (FRMERR) 55  
UART overrun error (OVERR) 55  
UART parity error (PARERR) 55  
UART receiver FIFO empty (URXFE) 46  
UART transmit FIFO full (UTXFF) 46  
UART transmitter busy (UBUSY) 46

**V**

Version ID (VERID) 47  
Video buffer size 52

**W**

Wake-up direct read (WUDR) 46  
Wake-up disable (WAKEDIS) 45  
Wake-up on (WUON) 46  
Watch dog expired interrupt (WEINT) 50  
Word length enable (WRDLEN) 56

## INDEX

### Numerics

208-pin VQFP package 75  
208-pin VQFP pin diagram 31

### A

abbreviations 9  
acronyms 9  
ARM710A  
    data sheet 12  
    microprocessor 11–13, 18–19, 28–29, 39, 44, 52, 71  
    World-Wide-Web site 12

### B

buffer  
    I/O characteristics 70  
bus conversion 48  
bus width conversion 48

### C

chip select address ranges  
    ROM mode 73  
conventions  
    abbreviations 9  
    acronyms 9  
    numbers and units 10

### D

DRAM controller 19  
    address mapping 20  
    refresh register 21, 49

### E

EPB Test mode signal assignment 71

### F

functional description  
    block diagram 11  
    overview 11

### I

interface bus width 73

### K

keyboard column drives 43

### L

LCD controller 12–14, 19, 21, 30, 44, 52  
    See registers, LCD Control

### M

memory interface  
    configuration registers 17, 47  
    memory map 39  
    reads 15  
    See also DRAM controller 19  
    writes 15  
Microwire 2, 12, 21, 45  
modes  
    16-bit I/O 48  
    4-bits-per-pixel 21  
    Burst 17  
    Debug 40, 44  
    Expansion Transfer 48  
    Free-running 23, 44  
    Hardware Test 70–74  
        Functional (EPB) Test 71  
        High-Z (System) Test 73  
        Oscillator and PLL Bypass 71  
        Oscillator and PLL Test 71  
        Pin Test 72  
        Test ROM 73  
    Idle 29  
    Page 12, 17, 49  
        timing 63–65  
    PCMCIA 18, 48  
        bus width 48  
        bus width field values 48  
    Pin Test 70  
    Prescale 23, 44  
    Self-refresh 27, 49  
    Standby 19, 27–29, 59  
    System Test (High-Z) 70

### N

NPOR. See resets, asynchronous  
NPWRFL. See resets, asynchronous  
NSYSRES. See resets, asynchronous  
NURESET. See resets, asynchronous

### O

ordering information 76

**P**

PCMCIA memory area 48  
pin diagram 31  
pin information  
  A[0–27] 32  
  ADCCLK 33  
  ADCIN 33  
  ADCOUT 33  
  BATOK 33  
  BUZ 34  
  CL[1–2] 34  
  COL[0–7] 34  
  CS[4–7] 32  
  CTS 33  
  D[0–31] 32  
  DCD 33  
  DD[0–3] 34  
  DRA[12–0] 32  
  DRIVE[0–1] 34  
  DSR 33  
  EINT[3] 32  
  EXPCLK 32  
  EXPRDY 32  
  FB[0–1] 34  
  FRM 34  
  LEDDR 33  
  M 34  
  MEDCHG 32  
  MOSCIN/ MOSOUT 34  
  NADCCS 33  
  NBATCHG 33  
  NCAS[0–3] 32  
  NCS[0–3] 32  
  NEINT[1–2] 32  
  NEXTFIQ 32  
  NEXTPWR 33  
  NMOE 32  
  NMWE 32  
  NPOR 33  
  NPWRFL 33  
  NRAS[0–3] 32  
  NTEST[0–1] 34  
  numeric pin listing 35  
  NURESET 33  
  PA[0–7] 34  
  PB[0–7] 34  
  PC[0–7] 34  
  PCMCK 33  
  PCMIN 33  
  PCMOUT 33  
  PCMSYNC 33  
  PD[0–7] 34

PE[0–3] 34  
PHDIN 33  
RTCIN/ RTCOUT 34  
RUN 33  
RxD 33  
SMPLCK 33  
TxD 33  
WAKEUP 33  
WORD 32  
WRITE 32

**R**

random access speed 49  
random access wait state field 49  
registers  
  BOOT8BIT Mode 18  
  DRAM Refresh Period 21, 29–30, **49**  
  internal I/O memory locations table 40  
  Internal Mask. *See* ARM710A Data Sheet  
  Interrupt Mask 13, 40, 52  
  Interrupt Status 13, **50**  
    *See also* ARM710A Data Sheet  
  LCD Control 21, 40, **52**  
  Memory Configuration 73  
  Memory Configuration Register 1 18, 40, **47**  
  Memory Configuration Register 2 47  
  Output Shift 21  
  programming interface 39–59  
  Pump Control 24, 41, **54**  
  Realtime Clock Data 29, 40–41  
  Realtime Clock Match **53**  
  System Control 23, 26, 40, **43**  
  System Status Flags 21, 40, **45**  
  UART Bit Rate and Line Control 23, 41, 46, 51, **55**  
  UART Rx 13  
resets, asynchronous **29–30**  
ROM 73

**S**

sequential access wait state field 49  
sequential random access speed 49  
signals  
  notional input 70  
software-selectable test functionality 74  
SPI 2, 12, 21, 45

**T**

timing  
  DRAM CAS-Before-RAS Refresh Cycle 68  
  DRAM Read Cycles 65  
  DRAM Write Cycles 66  
  Expansion and ROM Read 63



Expansion and ROM Write 64  
LCD Controller 69  
Video Quad Word Read 67

**U**

UART 1-2, 11

**W**

word bus conversion 48

## Direct Sales Offices

### *Domestic*

#### **N. CALIFORNIA**

Fremont  
TEL: 510/623-8300  
FAX: 510/252-6020

#### **S. CALIFORNIA**

Westlake Village  
TEL: 805/371-5860  
FAX: 805/371-5861

#### **NORTHWESTERN AREA**

Portland, OR  
TEL: 503/620-5547  
FAX: 503/620-5665

#### **SOUTH CENTRAL AREA**

Austin, TX  
TEL: 512/255-0080  
FAX: 512/255-0733

Irving, TX  
TEL: 972/252-6698  
FAX: 972/252-5681

Houston, TX  
TEL: 281/257-2525  
FAX: 281/257-2555

#### **NORTHEASTERN AREA**

Andover, MA  
TEL: 508/474-9300  
FAX: 508/474-9149

#### **SOUTHEASTERN AREA**

Raleigh, NC  
TEL: 919/859-5210  
FAX: 919/859-5334

Boca Raton, FL  
TEL: 407/241-2364  
FAX: 407/241-7990

### *International*

#### **CHINA**

Beijing  
TEL: 86/10-642-807-83-5  
FAX: 86/19-672-807-86

#### **FRANCE**

Paris  
TEL: 33/1-48-12-2812  
FAX: 33/1-48-12-2810

#### **GERMANY**

Herrsching  
TEL: 49/81-52-92460  
FAX: 49/81-52-924699

#### **HONG KONG**

Tsimshatsui  
TEL: 852/2376-0801  
FAX: 852/2375-1202

#### **ITALY**

Milan  
TEL: 39/2-3360-5458  
FAX: 39/2-3360-5426

#### **JAPAN**

Tokyo  
TEL: 81/3-3340-9111  
FAX: 81/3-3340-9120

#### **KOREA**

Seoul  
TEL: 82/2-565-8561  
FAX: 82/2-565-8565

#### **SINGAPORE**

TEL: 65/743-4111  
FAX: 65/742-4111

#### **TAIWAN**

Taipei  
TEL: 886/2-718-4533  
FAX: 886/2-718-4526

#### **UNITED KINGDOM**

London, England  
TEL: 44/1727-872424  
FAX: 44/1727-875919

---

## The Company

Headquartered in Fremont, California, Cirrus Logic is a leading manufacturer of advanced integrated circuits for desktop and portable computing, telecommunications, and consumer electronics. The Company applies its system-level expertise in analog and digital design to innovate highly integrated, software-rich solutions.

Cirrus Logic has developed a broad portfolio of products and technologies for applications spanning multimedia, graphics, communications, system logic, mass storage, and data acquisition.

The Cirrus Logic formula combines innovative architectures in silicon with system design expertise. We deliver complete solutions — chips, software, evaluation boards, and manufacturing kits — on-time, to help you win in the marketplace.

Cirrus Logic's manufacturing strategy ensures maximum product quality, availability, and value for our customers.

Talk to our systems and applications specialists; see how you can benefit from a new kind of semiconductor company.

Copyright © 1997 Cirrus Logic Inc. All rights reserved.

---

Cirrus Logic Inc. has made best efforts to ensure that the information contained in this document is accurate and reliable. However, the information is subject to change without notice. No responsibility is assumed by Cirrus Logic Inc. for the use of this information, nor for infringements of patents or other rights of third parties. This document is the property of Cirrus Logic Inc. and implies no license under patents, copyrights, or trade secrets. No part of this publication may be copied, reproduced, stored in a retrieval system, or transmitted, in any form or by any means, electronic, mechanical, photographic, or otherwise, or used as the basis for manufacture or sale of any items without the prior written consent of Cirrus Logic Inc. Cirrus, Cirrus Logic, AccuPak, Clear3D, DirectVPM, DIVA, FastPath, FasText, FeatureChips, FilterJet, Get into it, Good Data, Laguna, Laguna3D, MediaDAC, MotionVideo, RSA, SimuSCAN, S/LA, SMASH, SofTarget, Systems in Silicon, TextureJet, TVTap, UXART, Video Port Manager, VisualMedia, VPM, V-Port, Voyager, WavePort, and WebSet are trademarks of Cirrus Logic Inc., which may be registered in some jurisdictions. Other trademarks in this document belong to their respective companies. CRUS and Cirrus Logic International, Ltd. are trade names of Cirrus Logic Inc.