

TOSHIBA BIPOLAR DIGITAL INTEGRATED CIRCUIT SILICON MONOLITHIC

TD6330BP

STEPPING MOTOR DRIVER

The TD6330BP is an I²L monolithic IC designed to control a four-phase stepping motor.

It has a Schmitt input circuit for excellent noise immunity. It is also designed so that the frequency division ratio can be varied from outside to allow a variety of input signals to be processed.

The output is protected from induced voltage using a flyback protective circuit consisting of a diode and a Zener diode. The IC also has a pin for selecting forward or reverse rotation of the motor.

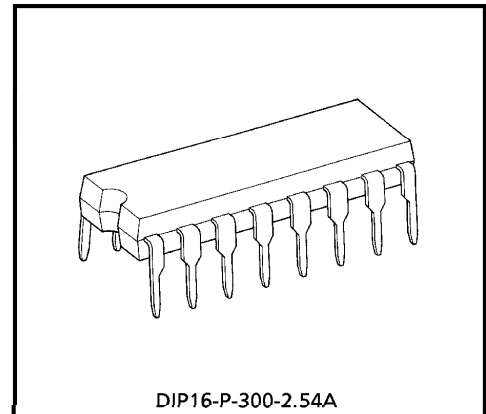

DIP16-P-300-2.54A

Weight : 1.0g (Typ.)

FEATURES

- High output current : 250mA / phase
- High output withstand voltage : 30V
- Schmitt input circuit incorporated
- Reshaping and frequency division output circuit incorporated
- Motor output frequency division ratio selectable
- Forward or reverse motor rotation selectable
- Motor output disabling possible
- Clamp diode incorporated
- Constant-voltage circuit incorporated
- Wide operating temperature range : from -40 to 90°C
- Plastic DIP-16pin

961001EBA2

- TOSHIBA is continually working to improve the quality and the reliability of its products. Nevertheless, semiconductor devices in general can malfunction or fail due to their inherent electrical sensitivity and vulnerability to physical stress. It is the responsibility of the buyer, when utilizing TOSHIBA products, to observe standards of safety, and to avoid situations in which a malfunction or failure of a TOSHIBA product could cause loss of human life, bodily injury or damage to property. In developing your designs, please ensure that TOSHIBA products are used within specified operating ranges as set forth in the most recent products specifications. Also, please keep in mind the precautions and conditions set forth in the TOSHIBA Semiconductor Reliability Handbook.
- The products described in this document are subject to foreign exchange and foreign trade control laws.
- The information contained herein is presented only as a guide for the applications of our products. No responsibility is assumed by TOSHIBA CORPORATION for any infringements of intellectual property or other rights of the third parties which may result from its use. No license is granted by implication or otherwise under any intellectual property or other rights of TOSHIBA CORPORATION or others.
- The information contained herein is subject to change without notice.

BLOCK DIAGRAM AND PIN LAYOUT

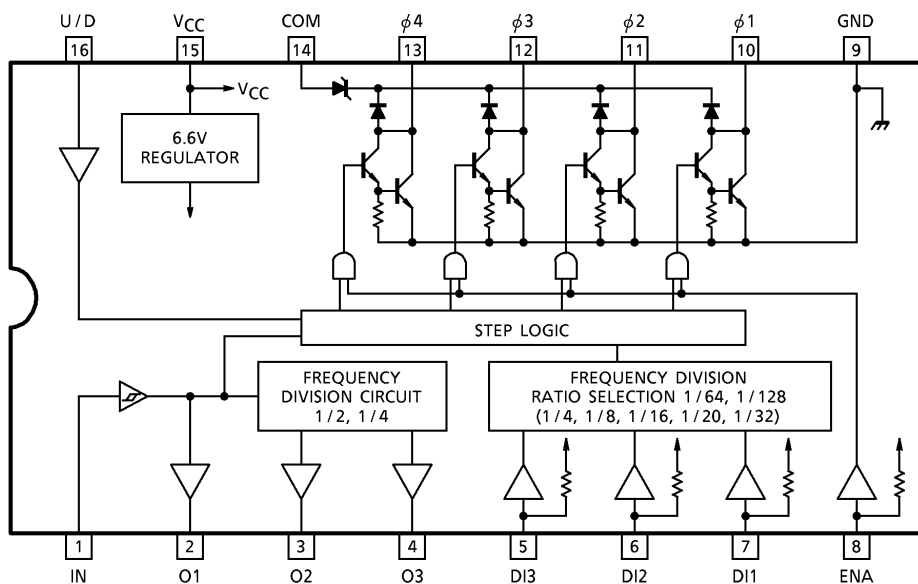

PIN DESCRIPTION

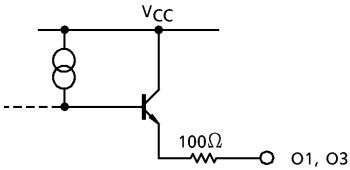
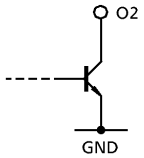
PIN No.	SYMBOL	DESCRIPTION
1	IN	The input circuit is a PNP-transistor voltage comparator made up of a Schmitt input circuit. It is supplied with a basic clock which determines the timing of excitation output.
2	O1	Supplies a reshaped IN signal. The output circuit is as follows : 
3	O2	Supplies the result of dividing the frequency of the IN input by 2. The output is an open-collector output as indicated below. 
4	O3	Supplies the result of dividing the frequency of the IN input by 4. The output circuit is the same as with O1. The outputs O1 and O2 are not synchronized.

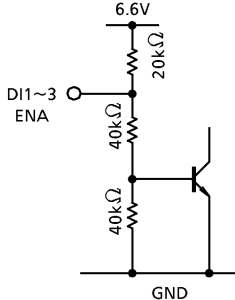
PIN No.	SYMBOL	DESCRIPTION
5 to 7	DI1 to DI3	<p>The signal from this input pin determines the frequency division ratio for the excitation output. The input circuit is shown at right.</p> 
8	ENA	Disables excitation output. When ENA is low, excitation outputs $\phi 1$ to $\phi 4$ are always off. The input circuit is the same as with DI1 to DI3.
9	GND	Grounded
10 to 13	$\phi 1$ to $\phi 4$	Excitation output pins each of which connects to an NPN Darlington transistor. A clamp diode is connected to each of these output circuits.
14	COM	Common pin for the clamp circuits. This pin connects to the clamp diodes for the excitation outputs via Zener diodes.
15	V_{CC}	Power supply pin
16	U/D	The signal from this pin determines the sequence of the excitation outputs so that the direction of motor rotation can be changed. When U/D is high, the sequence is from bottom to top ; when it is low, the sequence is from top to bottom. The input circuit is the same as with DI1 to DI3.

POWER-ON RESET

The voltage which terminates power-on reset state is 2.0-3.3V. Immediately after the power-on reset state terminates, the excitation outputs ($\phi 1$, $\phi 2$, $\phi 3$, $\phi 4$) are, respectively, ON, ON, OFF, OFF ; OFF, ON, ON, OFF (if pin 16 is UP) ; or ON, OFF, OFF, ON (if pin 16 is DOWN).

TIMING CHART

(1) Division by 4 (example)

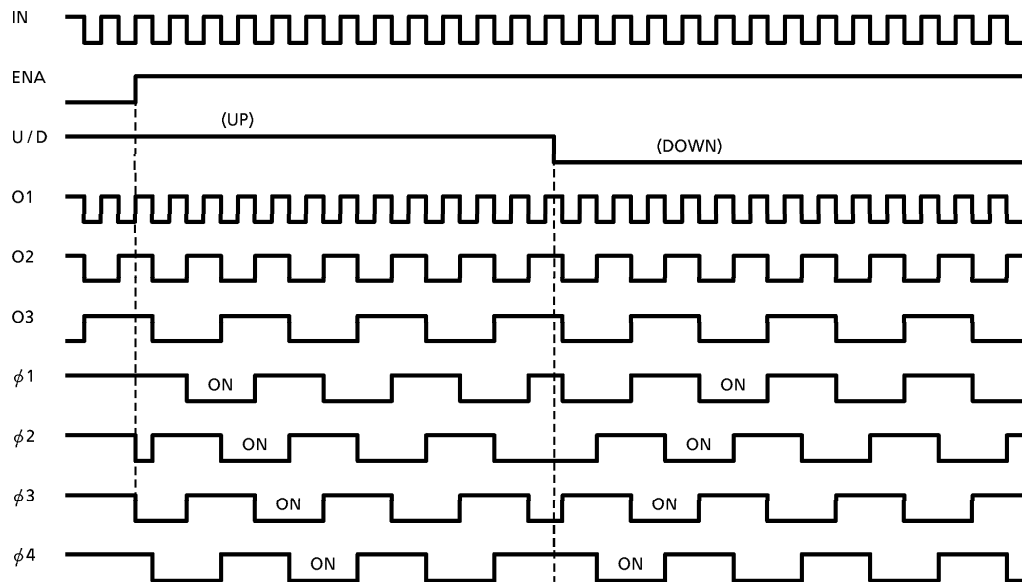

(2) Division by 8 (example of upward sequence)

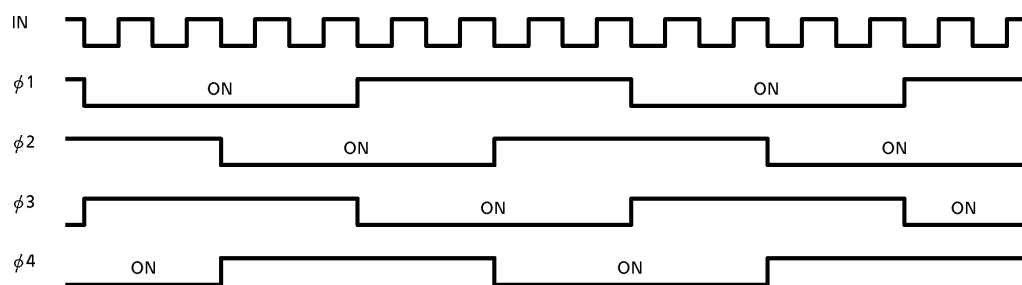

TRUTH TABLE

(1) Frequency Division Ratio

INPUT			EXCITATION OUTPUT			
DI3	DI2	DI1	$\phi 1$	$\phi 2$	$\phi 3$	$\phi 4$
0	0	0	Division by 64			
0	0	1	Division by 4			
0	1	0	Division by 8			
0	1	1	Division by 16			
1	0	0	Division by 32			
1	0	1	Division by 20			
1	1	0	Division by 128			
1	1	1	ON	ON	ON	ON

(2) Excitation sequence (division by 4, upward)

PHASE	ENA = 0	1	2	3	4	5
$\phi 1$	1	0	0	1	1	0
$\phi 2$	1	1	0	0	1	1
$\phi 3$	1	1	1	0	0	1
$\phi 4$	1	0	1	1	0	0

(3) Excitation sequence (division by 4, downward)

PHASE	ENA = 0	1	2	3	4	5
$\phi 1$	1	0	0	1	1	0
$\phi 2$	1	0	1	1	0	0
$\phi 3$	1	1	1	0	0	1
$\phi 4$	1	1	0	0	1	1

MAXIMUM RATINGS (Ta = 25°C)

CHARACTERISTIC	SYMBOL	PIN	RATING	UNIT
Supply Voltage	V _{CC}	V _{CC}	30	V
Output Current	I _{OUT}	$\phi 1 \sim \phi 4$	250	mA
Output Voltage	V _{OUT}	$\phi 1 \sim \phi 4$	30	V
Input Current	I _{IN}	IN	± 5	mA
Output Current	I _{OUT}	O1, O3	- 5	mA
		O2	5	
Output Voltage	V _{OUT}	O1, O3	- 0.3~V _{CC} +0.3	V
		O2	- 0.3~18	
Power Dissipation	P _D	—	1	W
Operating Temperature	T _{opr}	—	- 40~90	°C
Storage Temperature	T _{stg}	—	- 55~150	°C

ELECTRICAL CHARACTERISTICS ($V_{CC} = 16V, T_a = 25^\circ C$)

(1) DC CHARACTERISTIC

CHARACTERISTIC	SYMBOL	PIN	TEST CIR-CUIT	TEST CONDITION	MIN.	TYP.	MAX.	UNIT
Operation Voltage	V_{opr}	V_{CC}	—	—	5	—	—	V
Input Current	I_{IN}	IN	—	$V_{IN} = 0 \sim 5V$	-5	—	5	μA
Input Detect Voltage	V_{T+}	IN	—	—	3.2	3.80	4.0	V
	V_{T-}		—	—	2.0	2.46	2.6	
Output Voltage	V_{OH}	O1, O3	—	$I_{OH} = -2mA$	$V_{CC} - 1.5$	—	—	V
	V_{OL}	O2	—	$I_{OL} = 2mA$	—	—	0.5	
Output Leakage Current	I_{LEAK}	O1, O3	—	$V_{OUT} = 0V$	—	—	-10	μA
		O2	—	$V_{OUT} = 16V$	—	—	10	
Input Voltage	V_{IH}	DI1~3	—	—	2	—	—	V
	V_{IL}	ENA, U/D	—	—	—	—	0.6	
Input Current	I_{IH}	DI1~3	—	$V_{IN} = 4V$	—	—	-200	μA
	I_{IL}	ENA, U/D	—	$V_{IN} = 0.3V$	—	—	-600	
Output Leakage Current	I_{LEAK}	$\phi 1 \sim \phi 4$	—	$V_{OUT} = 30V$	—	—	500	μA
Output Voltage	V_{OL}	$\phi 1 \sim \phi 4$	—	$I_{OUT} = 200mA$	—	—	1.3	V
			—	$I_{OUT} = 200mA, T_a = 85^\circ C$	—	—	1.2	
Clamp Diode Leakage Current	I_R	$\phi 1 \sim \phi 4$	—	$V_R = 30V$	—	—	50	μA
Clamp Diode Forward Voltage	V_F	$\phi 1 \sim \phi 4$	—	$I_F = 200mA$	6	—	14	V
Current Consumption	I_{CC}	V_{CC}	—	All Input Opened	—	—	15	mA
Input Detect Hysteresis Voltage	ΔV_T	IN	—	—	1.2	1.34	—	V

(2) AC CHARACTERISTIC

CHARACTERISTIC	SYMBOL	PIN	TEST CIR-CUIT	TEST CONDITION	MIN.	TYP.	MAX.	UNIT
Input Frequency	f_{IN}	—	—	—	—	—	100	kHz
Input Pulse Width	t_{WL} / t_{WH}	—	—	—	3	—	—	μs
Input Rise Time	t_r	—	—	—	—	—	500	μs
Input Fall Time	t_f	—	—	—	—	—	500	μs

(Note) IN denotes input

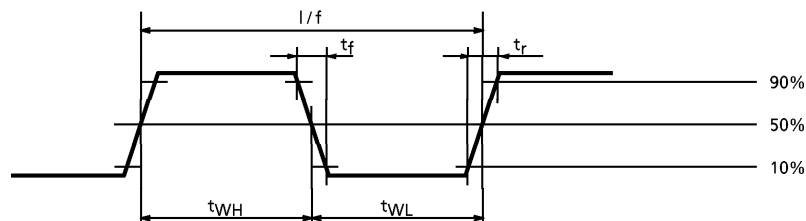

EXAMPLE OF APPLICATION CIRCUIT

(1) Division by 16, upward (surge voltage application as from automotive battery)

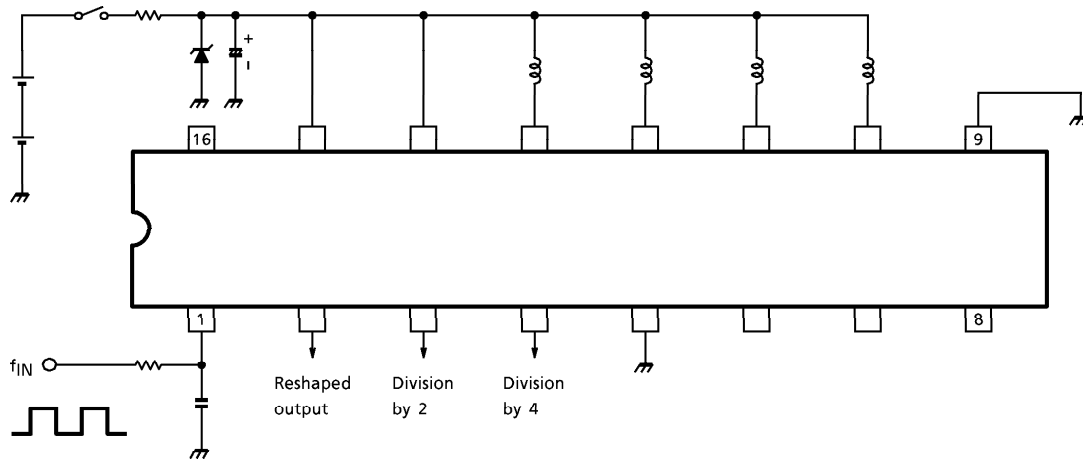

(2) Division by 8, upward (assuming a regulated power supply which is free from surge voltage)

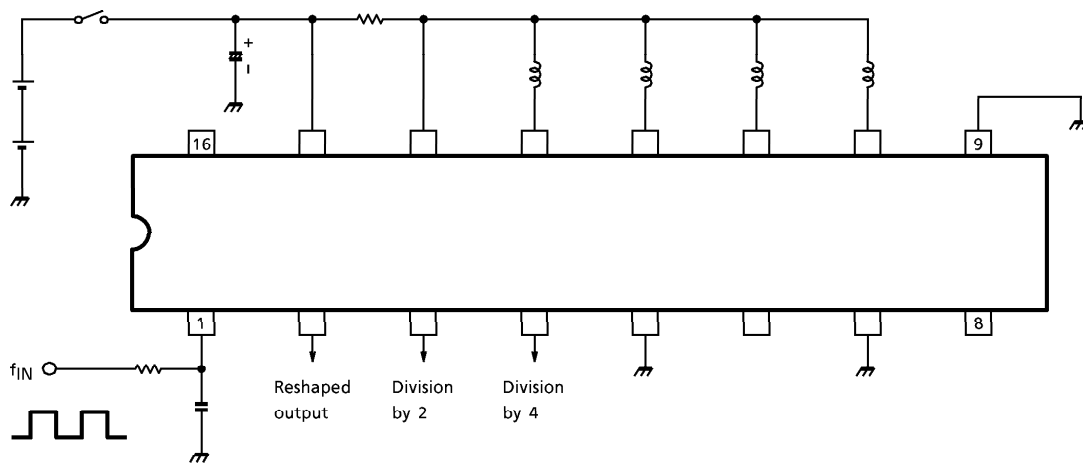

OUTLINE DRAWING
DIP16-P-300-2.54A

Unit : mm

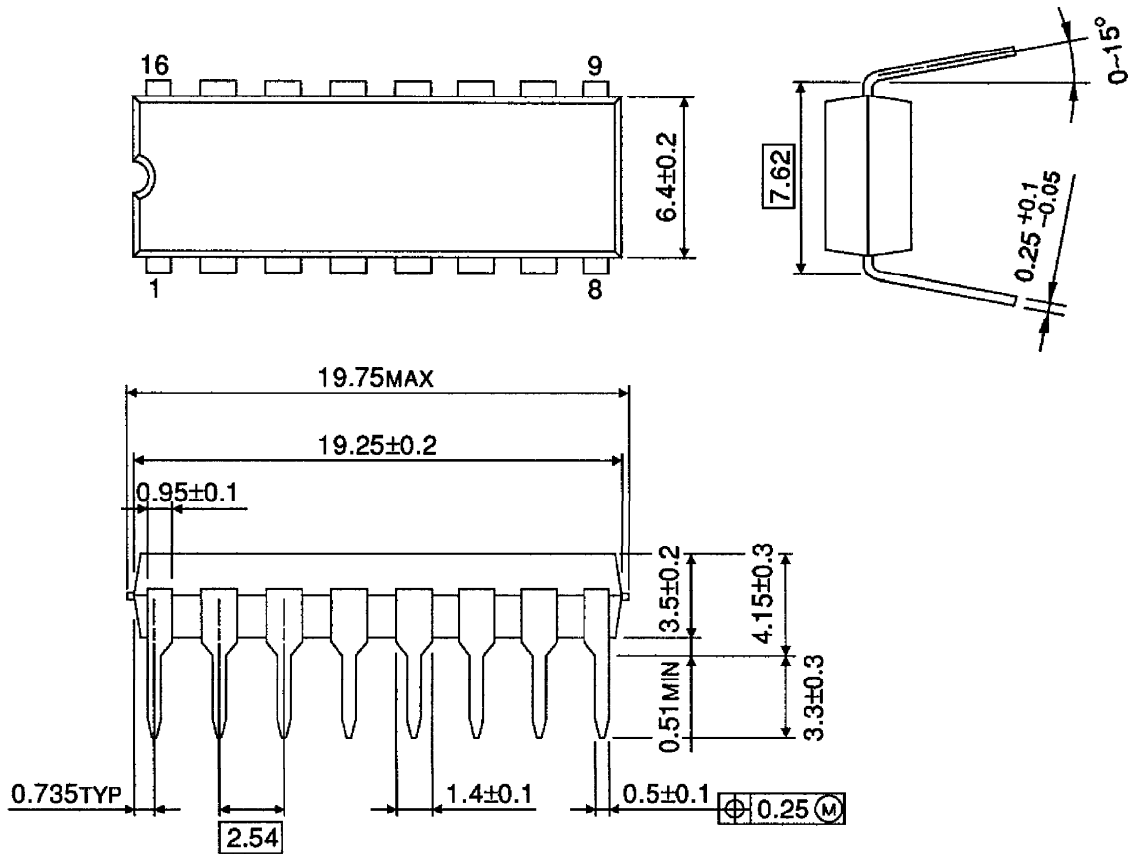

Weight : 1.0g (Typ.)