

The RF Line  
**Gallium Arsenide  
 CATV Amplifier Module**



**870 MHz  
 14.3 dB GAIN  
 132-CHANNEL  
 GaAs CATV AMPLIFIER MODULE**

**Features**

- Specified for 79-, 112- and 132-Channel Loading
- Excellent Distortion Performance
- Built-in Input Diode Protection
- GaAs FET Transistor Technology
- Unconditionally Stable Under All Load Conditions

**Applications**

- CATV Systems Operating in the 40 to 870 MHz Frequency Range
- Input Stage Amplifier in Optical Nodes, Line Extenders and Trunk Distribution Amplifiers for CATV Systems
- Output Stage Amplifier on Applications Requiring Low Power Dissipation and High Output Performance
- Driver Amplifier in Linear General Purpose Applications

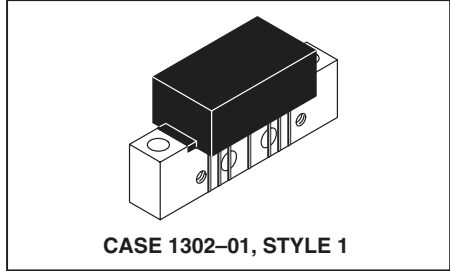

**Description**

- 24 Vdc Supply, 40 to 870 MHz, CATV GaAs Forward Amplifier Module

**MAXIMUM RATINGS**

Rating	Symbol	Value	Unit
RF Voltage Input (Single Tone)	$V_{in}$	+65	dBmV
DC Supply Voltage	$V_{CC}$	+26	Vdc
Operating Case Temperature Range	$T_C$	-20 to +100	°C
Storage Temperature Range	$T_{stg}$	-40 to +100	°C

**ESD MAXIMUM RATINGS**

Rating	Input Value	Output Value	Unit
Surge Voltage per IEC 1000-4-5	200	200	V
Human Body Model per Mil. Std. 1686	2	2	kV

**ELECTRICAL CHARACTERISTICS** ( $V_{CC} = 24$  Vdc,  $T_C = +45^\circ\text{C}$ , 75  $\Omega$  system unless otherwise noted)

Characteristic	Symbol	Min	Typ	Max	Unit
Frequency Range	BW	40	—	870	MHz
Power Gain 870 MHz	$G_p$	13.8	14.3	14.8	dB
Slope 40-870 MHz	S	0	0.4	1.0	dB
Gain Flatness (40-870 MHz, Peak-to-Valley)	$G_F$	—	—	0.5	dB
Return Loss — Input ( $Z_o = 75$ Ohms)	IRL	20	—	—	dB
		18	—	—	
Return Loss — Output ( $Z_o = 75$ Ohms)	ORL	20	—	—	dB
		18	—	—	

# Freescale Semiconductor, Inc.

## ELECTRICAL CHARACTERISTICS – continued ( $V_{CC} = 24 \text{ Vdc}$ , $T_C = +45^\circ\text{C}$ , $75 \Omega$ system unless otherwise noted)

Characteristic		Symbol	Min	Typ	Max	Unit
Composite Second Order ( $V_{out} = +48 \text{ dBmV/ch.}$ , Worst Case) ( $V_{out} = +46 \text{ dBmV/ch.}$ , Worst Case) ( $V_{out} = +44 \text{ dBmV/ch.}$ , Worst Case)	79–Channel FLAT	$CSO_{79}$	—	–68	–64	dBc
	112–Channel FLAT	$CSO_{112}$	—	–63	–60	
	132–Channel FLAT	$CSO_{132}$	—	–63	–60	
Cross Modulation Distortion @ Ch 2 ( $V_{out} = +48 \text{ dBmV/ch.}$ , FM = 55.25 MHz ) ( $V_{out} = +46 \text{ dBmV/ch.}$ , FM = 55.25 MHz) ( $V_{out} = +44 \text{ dBmV/ch.}$ , FM = 55.25 MHz)	79–Channel FLAT	$XMD_{79}$	—	–60	–55	dBc
	112–Channel FLAT	$XMD_{112}$	—	–60	–55	
	132–Channel FLAT	$XMD_{132}$	—	–60	–55	
Composite Triple Beat ( $V_{out} = +48 \text{ dBmV/ch.}$ , Worst Case) ( $V_{out} = +46 \text{ dBmV/ch.}$ , Worst Case) ( $V_{out} = +44 \text{ dBmV/ch.}$ , Worst Case)	79–Channel FLAT	$CTB_{79}$	—	–64	–60	dBc
	112–Channel FLAT	$CTB_{112}$	—	–64	–60	
	132–Channel FLAT	$CTB_{132}$	—	–64	–60	
Noise Figure	50 MHz	NF	—	4.4	5.5	dB
	550 MHz		—	3.8	—	
	750 MHz		—	4.0	—	
	870 MHz		—	4.3	5.5	
DC Current ( $V_{DC} = 24 \text{ V}$ , $T_C = 45^\circ\text{C}$ )		$I_{DC}$	230	245	260	mA

NOTE: This device requires an external  $0.01 \mu\text{F}$  DC blocking capacitor connected to the output pin (Pin 9) as indicated in Figure 1.

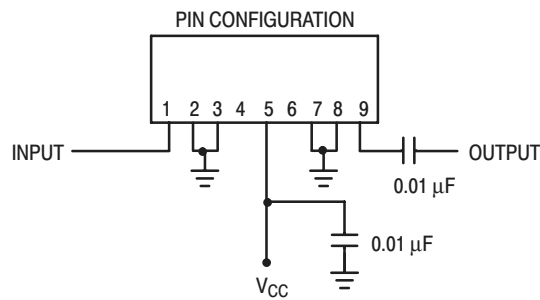
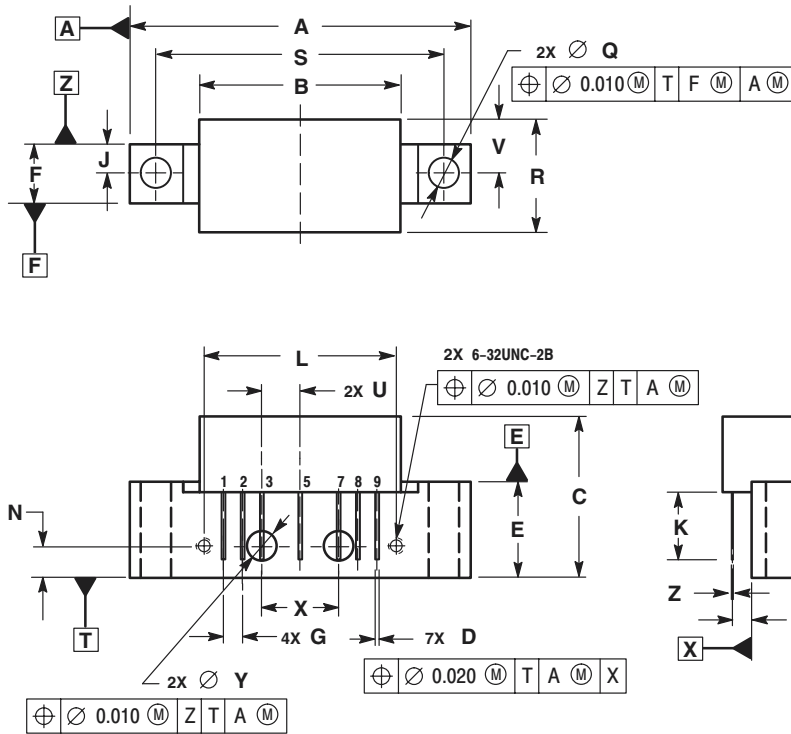

Figure 1. External Connections

**NOTES**

# Freescale Semiconductor, Inc.

## PACKAGE DIMENSIONS



- NOTES:  
 1. DIMENSIONS ARE IN INCHES.  
 2. INTERPRET DIMENSIONS AND TOLERANCES PER ASME Y14.5M, 1994.

DIM	INCHES		MILLIMETERS	
	MIN	MAX	MIN	MAX
A	---	1.775	---	45.085
B	---	1.085	---	27.559
C	---	0.840	---	21.336
D	0.015	0.021	0.381	0.533
E	0.465	0.510	11.811	12.954
F	0.300	0.325	7.62	8.255
G	0.100 BSC		2.540 BSC	
J	0.156 BSC		3.962 BSC	
K	0.315	0.355	8.001	9.017
L	1.000 BSC		25.400 BSC	
N	0.165 BSC		4.191 BSC	
P	0.100 BSC		2.540 BSC	
Q	0.148	0.168	3.759	4.267
R	---	0.600	---	15.24
S	1.500 BSC		38.100 BSC	
U	0.200 BSC		5.080 BSC	
V	---	0.250	---	6.350
W	0.435	---	11.049	---
X	0.400 BSC		10.160 BSC	
Y	0.152	0.163	3.861	4.140
Z	0.009	0.011	0.229	0.279

- STYLE 1:  
 PIN 1: RF INPUT  
 2: GROUND  
 3: GROUND  
 4: DELETED  
 5: VDC  
 6: DELETED  
 7: GROUND  
 8: GROUND  
 9: RF OUTPUT

CASE 1302-01  
 ISSUE B

Motorola reserves the right to make changes without further notice to any products herein. Motorola makes no warranty, representation, or guarantee regarding the suitability of its products for any particular purpose, nor does Motorola assume any liability arising out of the application or use of any product or circuit, and specifically disclaims any and all liability, including without limitation consequential or incidental damages. "Typical" parameters can and do vary in different applications and actual performance may vary over time. All operating parameters, including "Typicals", must be validated for each customer application by customer's technical experts. Motorola does not convey any license under its patent rights nor the rights of others. Motorola products are not designed, intended, or authorized for use as components in systems intended for surgical implant into the body, or other applications intended to support or sustain life, or for any other application in which the failure of the Motorola product could create a situation where personal injury or death may occur. Should Buyer purchase or use Motorola products for any such unintended or unauthorized application, Buyer shall indemnify and hold Motorola and its officers, employees, subsidiaries, affiliates, and distributors harmless against all claims, costs, damages, and expenses, and reasonable attorney fees arising out of, directly or indirectly, any claim of personal injury or death associated with such unintended or unauthorized use, even if such claim alleges that Motorola was negligent regarding the design or manufacture of the part. Motorola and the Stylized M Logo are registered trademarks of Motorola, Inc. Motorola, Inc. is an Equal Opportunity/Affirmative Action Employer.

Motorola and the Stylized M Logo are registered in the US Patent & Trademark Office. All other product or service names are the property of their respective owners.

© Motorola, Inc. 2003.

### How to reach us:

**USA/EUROPE/Locations Not Listed:** Motorola Literature Distribution; P.O. Box 5405, Denver, Colorado 80217. 1-303-675-2140 or 1-800-441-2447

**JAPAN:** Motorola Japan Ltd.; SPS, Technical Information Center, 3-20-1, Minami-Azabu, Minato-ku, Tokyo 106-8573 Japan. 81-3-3440-3569

**ASIA/PACIFIC:** Motorola Semiconductors H.K. Ltd.; Silicon Harbour Centre, 2 Dai King Street, Tai Po Industrial Estate, Tai Po, N.T. Hong Kong. 852-26668334

**Technical Information Center:** 1-800-521-6274

**HOME PAGE:** <http://www.motorola.com/semiconductors>



**MOTOROLA**

For More Information On This Product,  
 Go to: [www.freescale.com](http://www.freescale.com)

MHW9146/D