

7078 × 3pixel CCD Linear Sensor (Color)

Description

The ILX520K is a reduction type CCD linear sensor developing for color image scanner. This sensor reads A3-size documents at a density of 600 DPI.

Features

- Number of effective pixels: 21234 pixels
(7078 pixels × 3)
- Pixel size: 8μm × 8μm (8μm pitch)
- Distance between line: 64μm (8 Lines)
- Single-sided readout
- Ultra low lag / Ultra high sensitivity
- Single 12V power supply
- Input clock pulse: CMOS 5V drive
- Number of output 3 (R, G, B)
- Package: 24 pin DIP (400 mil)

Absolute Maximum Ratings

- Supply voltage V_{DD} 15 V
- Operating temperature -10 to +55 °C
- Storage temperature -30 to +80 °C

Pin Configuration (Top View)

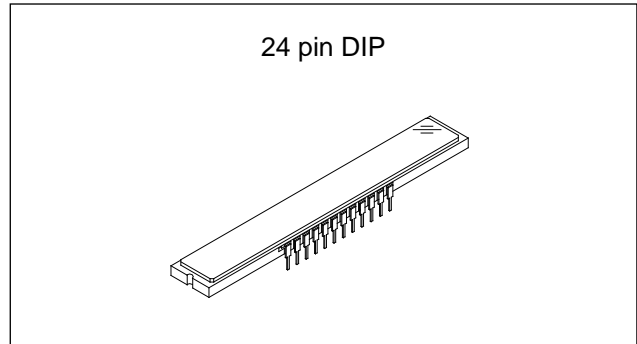
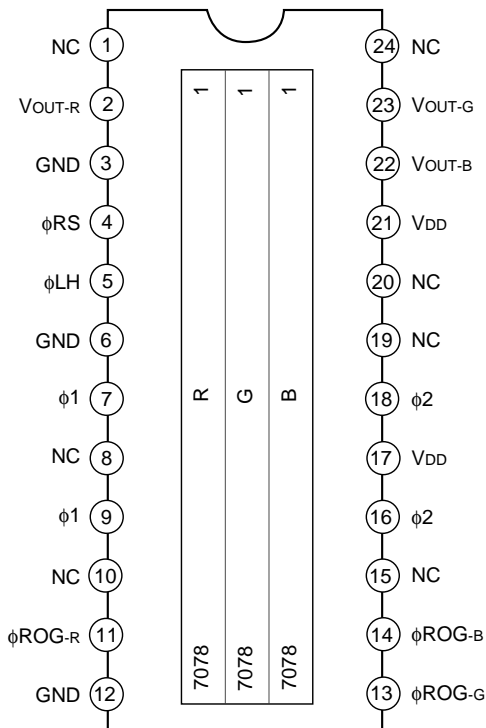

Block Diagram

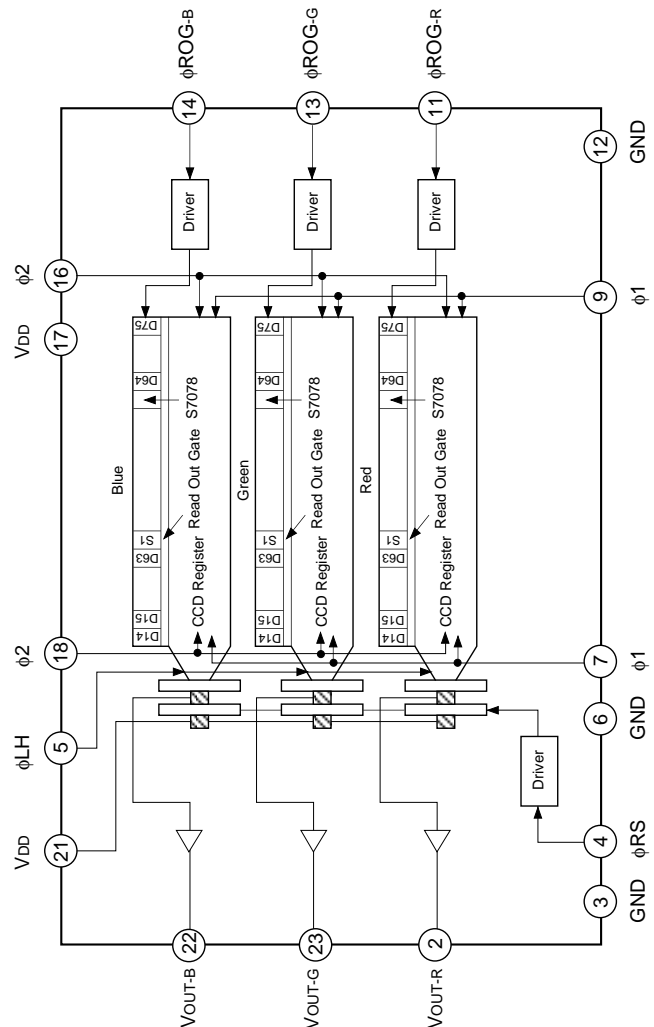

Sony reserves the right to change products and specifications without prior notice. This information does not convey any license by any implication or otherwise under any patents or other right. Application circuits shown, if any, are typical examples illustrating the operation of the devices. Sony cannot assume responsibility for any problems arising out of the use of these circuits.

Pin Description

Pin No.	Symbol	Description	Pin No.	Symbol	Description
1	NC	NC	13	ϕ ROG-G	Clock pulse input
2	V _{OUT-R}	Signal out (red)	14	ϕ ROG-B	Clock pulse input
3	GND	GND	15	NC	NC
4	ϕ RS	Clock pulse input	16	ϕ 2	Clock pulse input
5	ϕ LH	Clock pulse input	17	V _{DD}	12V power supply
6	GND	GND	18	ϕ 2	Clock pulse input
7	ϕ 1	Clock pulse input	19	NC	NC
8	NC	NC	20	NC	NC
9	ϕ 1	Clock pulse input	21	V _{DD}	12V power supply
10	NC	NC	22	V _{OUT-B}	Signal out (blue)
11	ϕ ROG-R	Clock pulse input	23	V _{OUT-G}	Signal out (green)
12	GND	GND	24	NC	NC

Recommended Supply Voltage

Item	Min.	Typ.	Max.	Unit
V _{DD}	11.4	12	12.6	V

Clock Characteristics

Item	Symbol	Min.	Typ.	Max.	Unit
Input capacity of ϕ 1, ϕ 2	C ϕ 1, C ϕ 2	—	1100	—	pF
Input capacity of ϕ LH	C ϕ LH	—	10	—	pF
Input capacity of ϕ RS	C ϕ RS	—	10	—	pF
Input capacity of ϕ ROG*	C ϕ ROG	—	10	—	pF

* It indicates that ϕ ROG-R, ϕ ROG-G, ϕ ROG-B as ϕ ROG.

Clock Frequency

Item	Symbol	Min.	Typ.	Max.	Unit
ϕ 1, ϕ 2, ϕ LH, ϕ RS	f ϕ 1, f ϕ 2, f ϕ LH, f ϕ RS	—	1	5	MHz

Input Clock Pulse Voltage Condition

Item	Min.	Typ.	Max.	Unit	
ϕ 1, ϕ 2, ϕ LH, ϕ RS, ϕ ROG pulse voltage	High level	4.75	5.0	5.25	V
	Low level	—	0	0.1	V

Electrooptical Characteristics (Note 1)

Ta = 25°C, VDD = 12V, fφRS = 1MHz, Input clock = 5Vp-p, Light source = 3200K, IR cut filter CM-500S (t = 1.0mm)

Item	Symbol	Min.	Typ.	Max.	Unit	Remarks	
Sensitivity	Red	RR	1.3	2.0	2.7	V/(lx · s)	Note 2
	Green	RG	2.1	3.2	4.3		
	Blue	RB	1.6	2.5	3.4		
Sensitivity nonuniformity	PRNU	—	4	20	%	Note 3	
Saturation output voltage	VSAT	2	3.2	—	V	Note 4	
Saturation exposure	Red	SE _R	0.74	1.6	—	lx · s	Note 5
	Green	SE _G	0.46	1	—		
	Blue	SE _B	0.58	1.28	—		
Dark voltage average	VDRK	—	0.3	2	mV	Note 6	
Dark signal nonuniformity	DSNU	—	1.5	5	mV	Note 6	
Image lag	IL	—	0.02	—	%	Note 7	
Supply current	IVDD	—	26	50	mA	—	
Total transfer efficiency	TTE	92	98	—	%	—	
Output impedance	Zo	—	250	—	Ω	—	
Offset level	Vos	—	6.5	—	V	Note 8	
Dynamic range	DR	1000	10670	—	—	Note 9	

Note

- 1) In accordance with the given electrooptical characteristics, the black level is defined as the average value of D2, D3 to D12.
- 2) For the sensitivity test light is applied with a uniform intensity of illumination.
- 3) PRNU is defined as indicated below. Ray incidence conditions are the same as for Note 2.

$$V_{OUT} = 500\text{mV (Typ.)}$$

$$PRNU = \frac{(V_{MAX} - V_{MIN}) / 2}{V_{AVE}} \times 100 [\%]$$

Where the 7078 pixels are divided into blocks of 114 (Last block is 124 pixel). The maximum output of each block is set to V_{MAX}, the minimum output to V_{MIN} and the average output to V_{AVE}.

- 4) Use below the minimum value of the saturation output voltage.
- 5) Saturation exposure is defined as follows.

$$SE = \frac{V_{SAT}}{R}$$

Where R indicates RR, RG, RB, and SE indicates SE_R, SE_G, SE_B.

- 6) Optical signal accumulated time τ int stands at 10ms.
- 7) V_{OUT} = 500mV (Typ.)
- 8) Vos is defined as indicated bellow.

V_{OUT} indicates V_{OUT-R}, V_{OUT-G}, and V_{OUT-B}.

- 9) Dynamic range is defined as follows.

$$DR = \frac{V_{SAT}}{V_{DRK}}$$

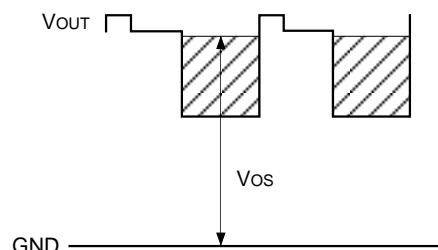

When the optical signal accumulated time is shorter, the dynamic range gets wider because the optical signal accumulated time is in proportion to the dark voltage.

Clock Timing Chart 1

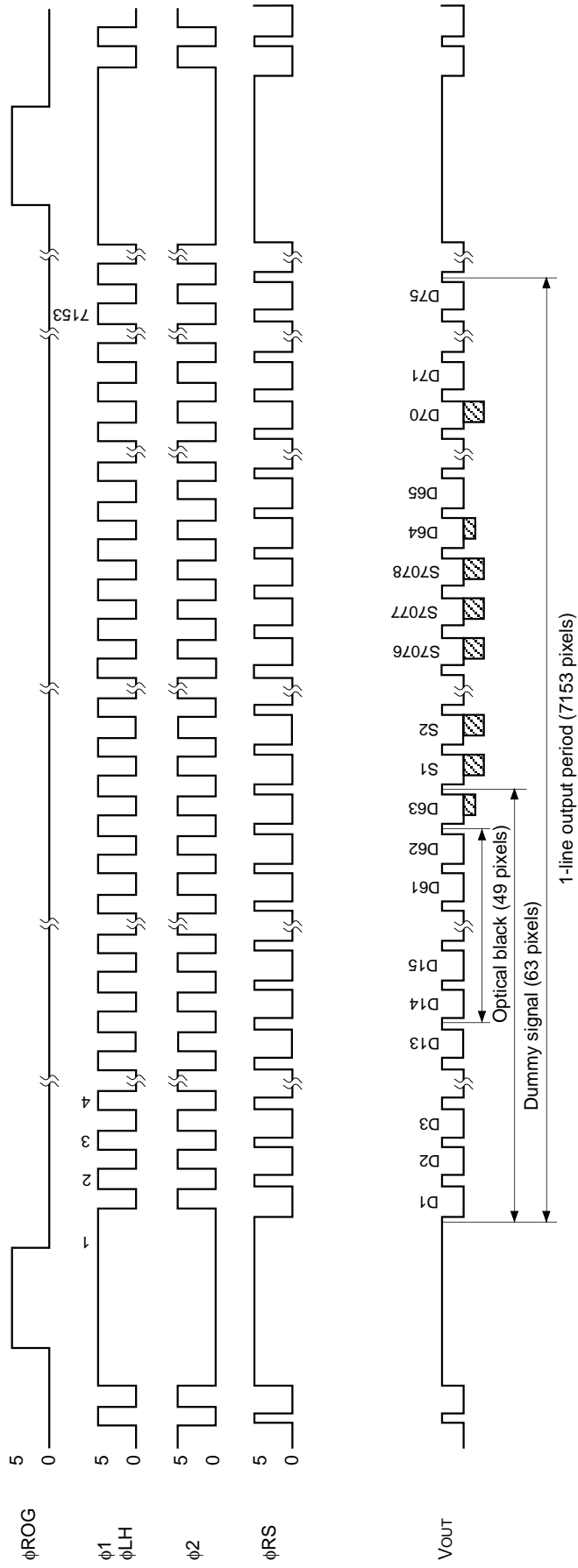

Note) The transfer pulses ($\phi1$, $\phi2$, ϕLH) must have more than 7153 cycles.

Clock Timing Chart 2

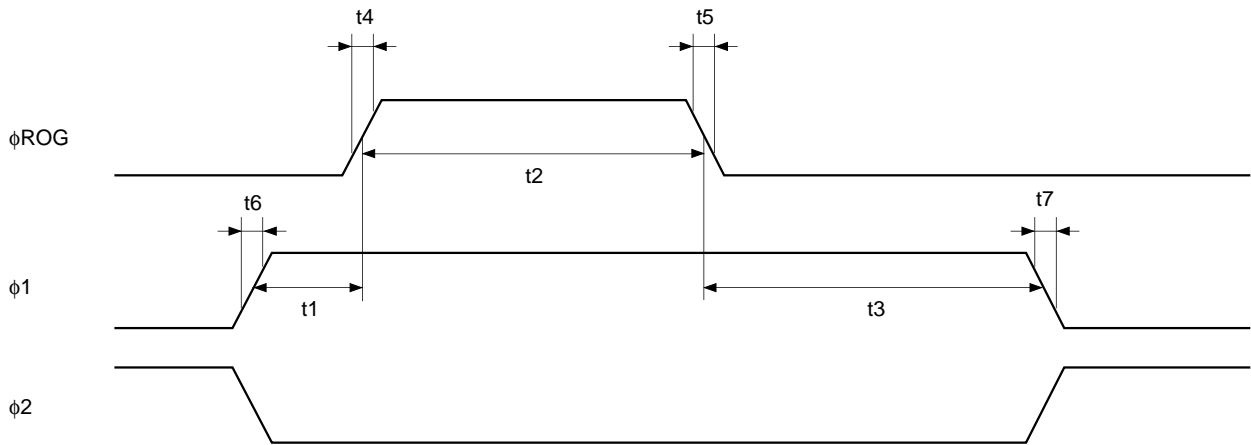

Clock Timing Chart 3

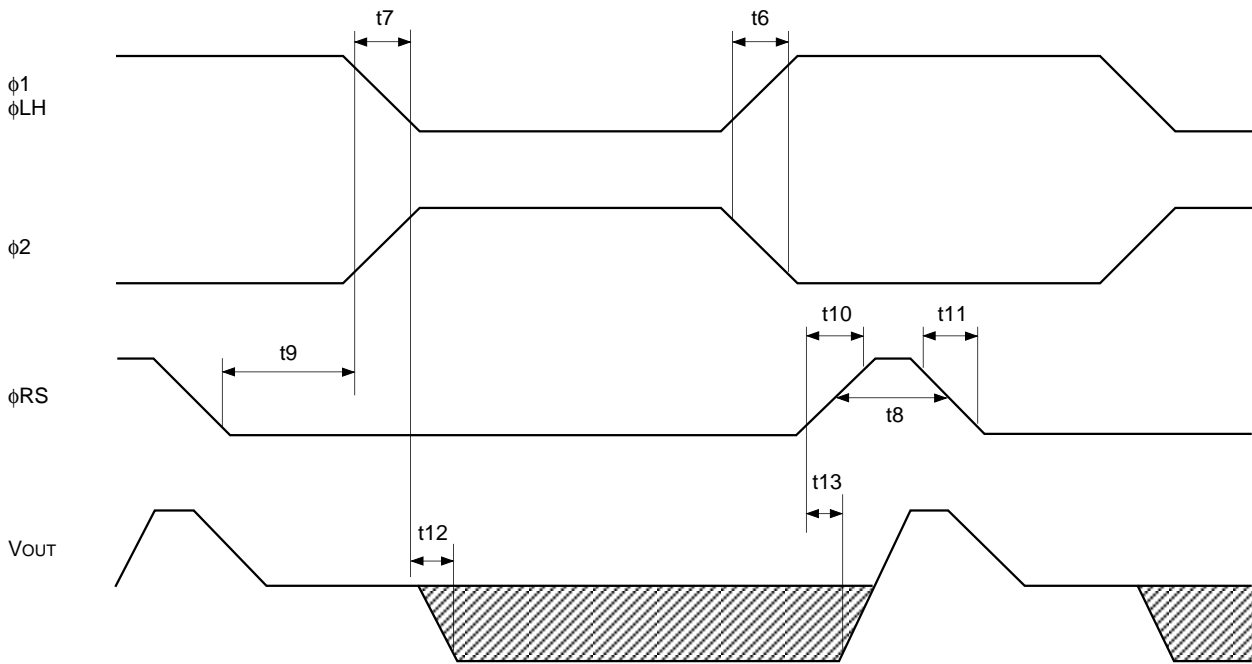

Clock Pulse Recommended Timing

Item	Symbol	Min.	Typ.	Max.	Unit
ϕ ROG, ϕ 1 pulse timing	t1	50	100	—	ns
ϕ ROG pulse high level period	t2	1200	1500	—	ns
ϕ ROG, ϕ 1 pulse timing	t3	1200	1500	—	ns
ϕ ROG pulse rise time	t4	0	5	10	ns
ϕ ROG pulse fall time	t5	0	5	10	ns
ϕ 1 pulse rise time / ϕ 2 pulse fall time	t6	0	20	60	ns
ϕ 1 pulse fall time / ϕ 2 pulse rise time	t7	0	20	60	ns
ϕ RS pulse high level period	t8	45	250*1	—	ns
ϕ RS, ϕ LH pulse timing	t9	45	250*1	—	ns
ϕ RS pulse rise time	t10	0	10	30	ns
ϕ RS pulse fall time	t11	0	10	30	ns
Signal output delay time	t12	—	10	—	ns
	t13	—	10	—	ns

*1 These timing is the recommended condition under $f_{\phi RS} = 1\text{MHz}$.

Application Circuit*

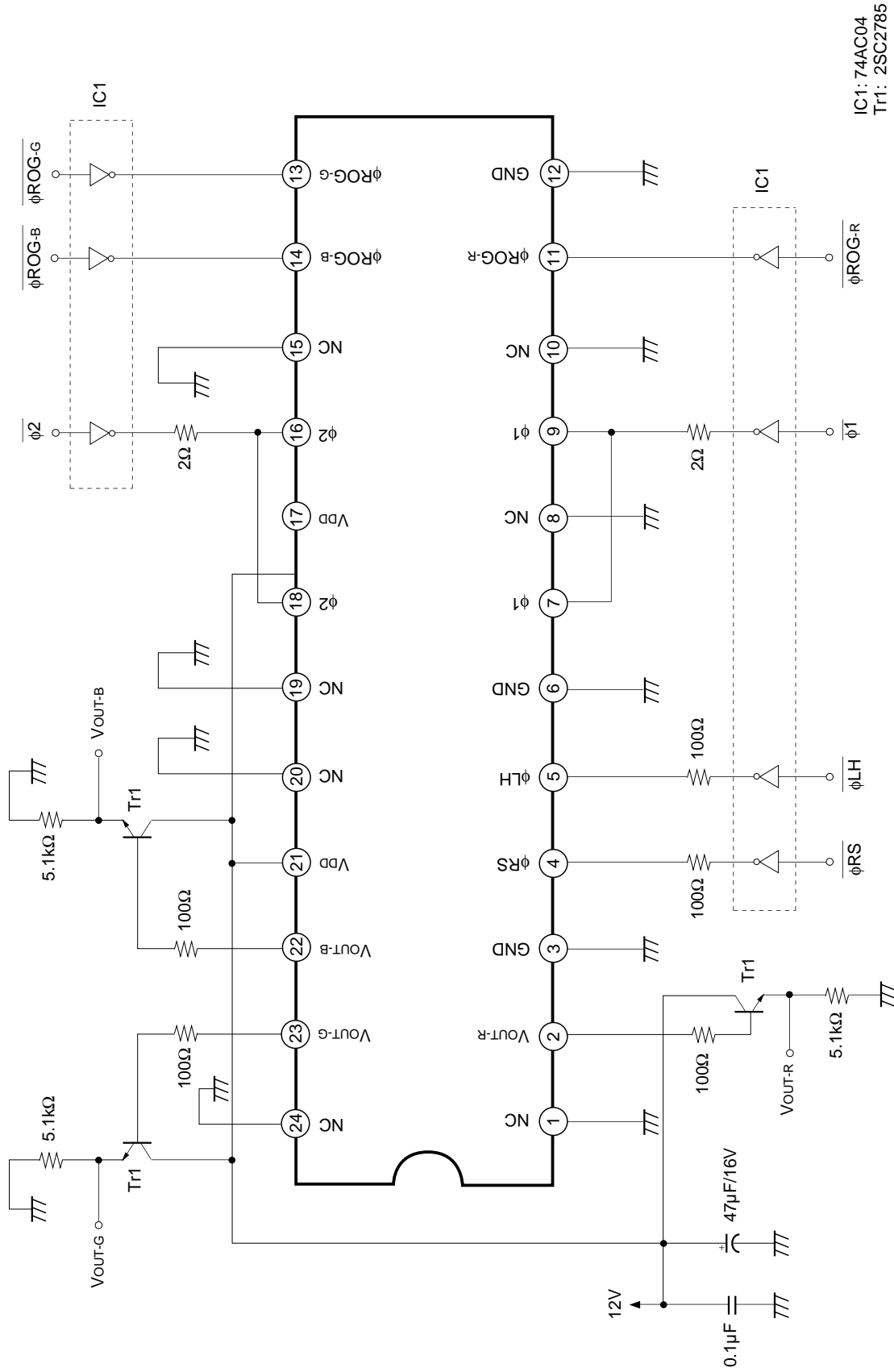

IC1: 74AC04
Tr1: 2SC2785

Application circuits shown are typical examples illustrating the operation of the devices. Sony cannot assume responsibility for any problems arising out of the use of these circuits or for any infringement of third party patent and other right due to same.

* Data rate $f_{\phi RS} = 1\text{MHz}$.

Example of Representative Characteristics ($V_{DD} = 12V$, $T_a = 25^\circ C$)

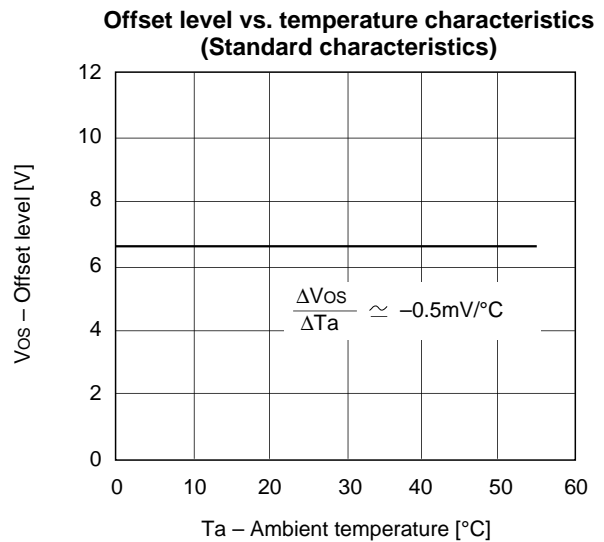
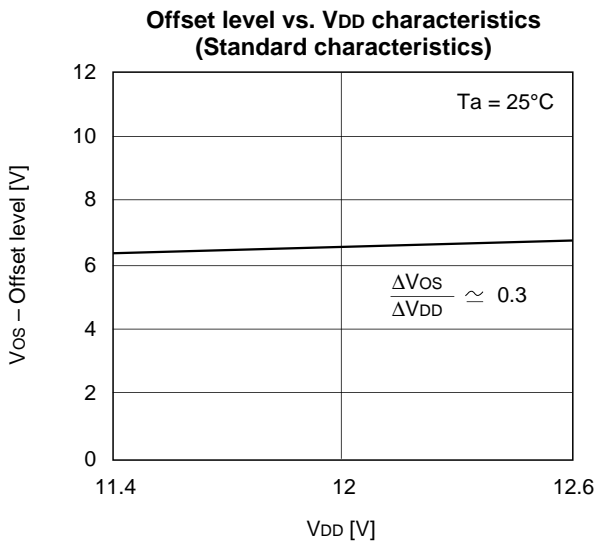
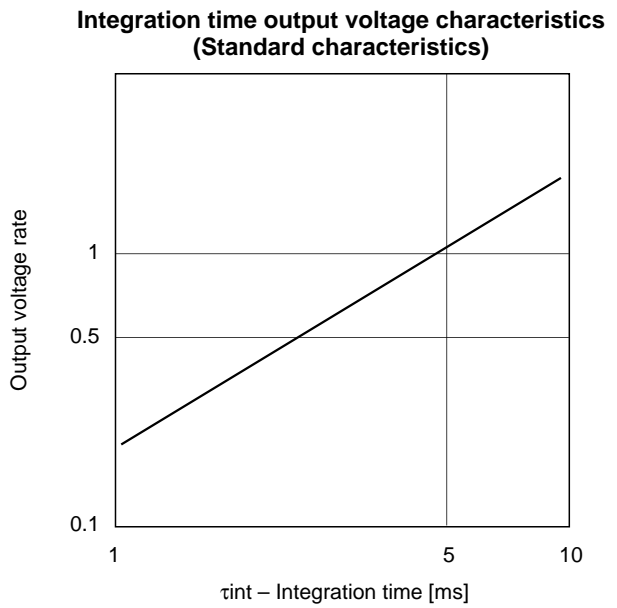
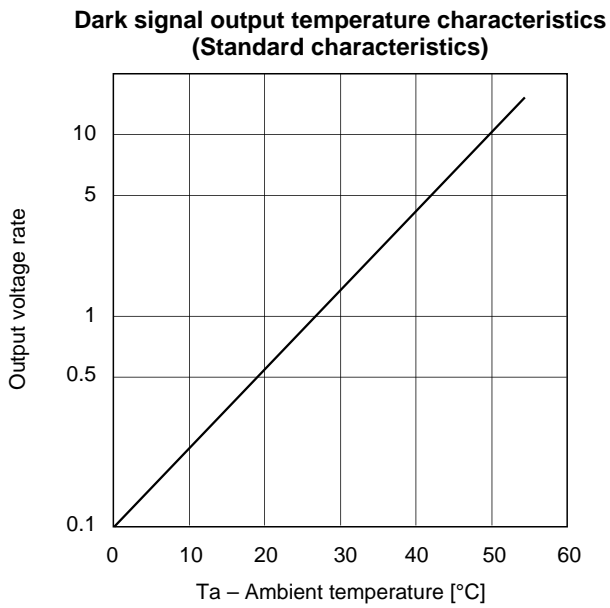
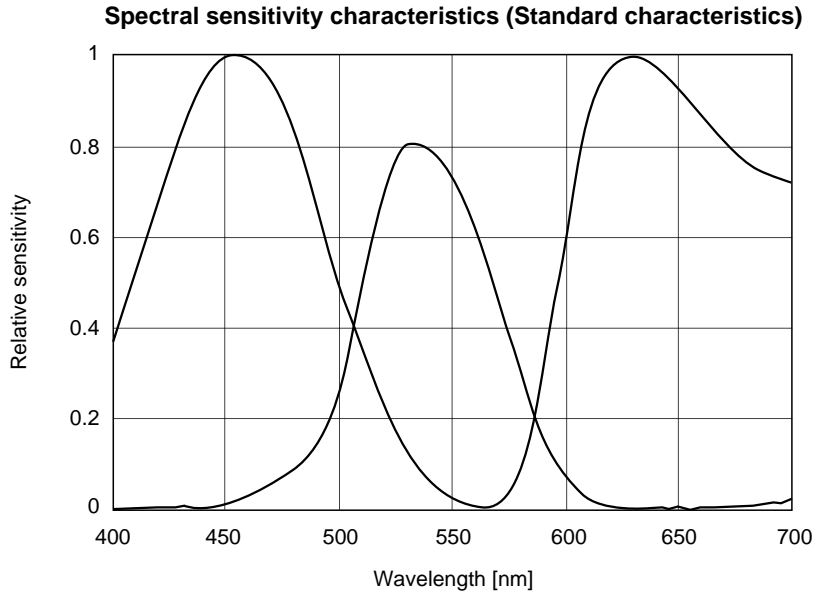

Notes of Handling

- 1) Static charge prevention
CCD image sensors are easily damaged by static discharge. Before handling be sure to take the following protective measures.
 - a) Either handle bare handed or use non chargeable gloves, clothes or material. Also use conductive shoes.
 - b) When handling directly use an earth band.
 - c) Install a conductive mat on the floor or working table to prevent the generation of static electricity.
 - d) Ionized air is recommended for discharge when handling CCD image sensor.
 - e) For the shipment of mounted substrates, use boxes treated for prevention of static charges.

- 2) Soldering
 - a) Make sure the package temperature does not exceed 80°C.
 - b) Solder dipping in a mounting furnace causes damage to the glass and other defects. Use a grounded 30W soldering iron and solder each pin in less then 2 seconds. For repairs and remount, cool sufficiently.
 - c) To dismount an imaging device, do not use a solder suction equipment. When using an electric desoldering tool, ground the controller. For the control system, use a zero cross type.

- 3) Dust and dirt protection
 - a) Operate in clean environments.
 - b) Do not either touch glass plates by hand or have any object come in contact with glass surfaces. Should dirt stick to a glass surface, blow it off with an air blower. (For dirt stuck through static electricity ionized air is recommended.)
 - c) Clean with a cotton bud and ethyl alcohol if the glass surface is grease stained. Be careful not to scratch the glass.
 - d) Keep in a case to protect from dust and dirt. To prevent dew condensation, preheat or precool when moving to a room with great temperature differences.

- 4) Exposure to high temperatures or humidity will affect the characteristics. Accordingly avoid storage or usage in such conditions.

- 6) CCD image sensors are precise optical equipment that should not be subject to mechanical shocks.

Package Outline

Unit: mm

24Pin DIP (400mil)

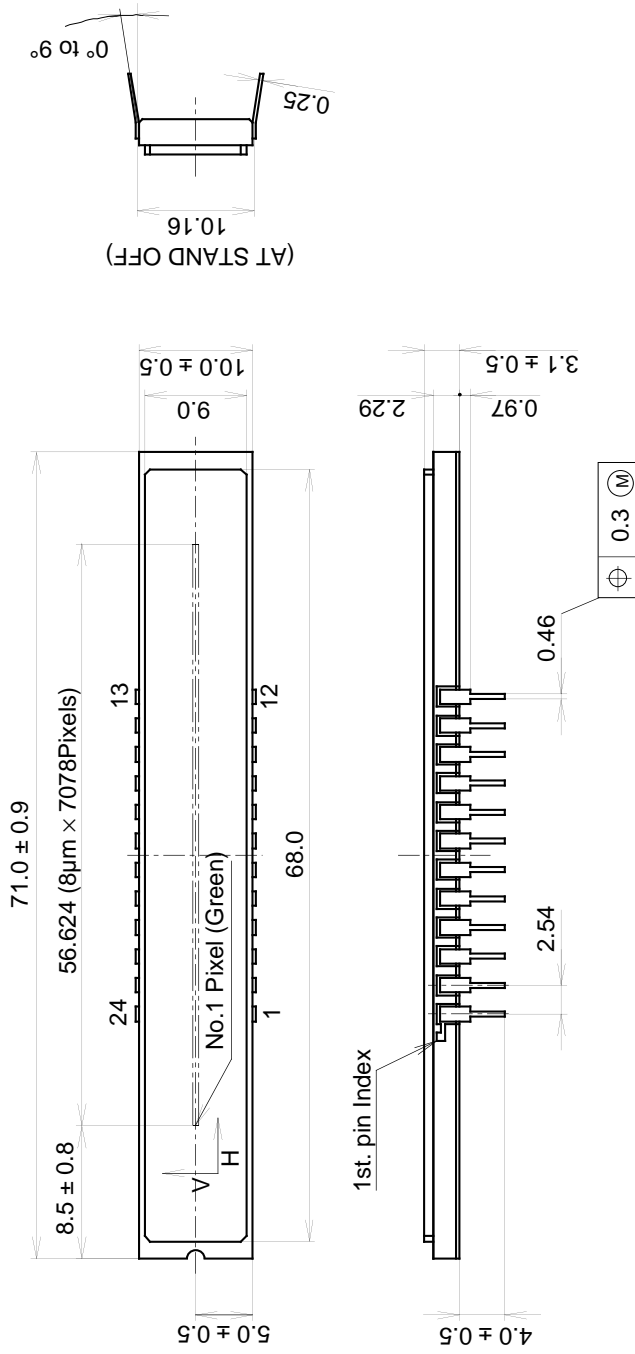

1. The height from the bottom to the sensor surface is $1.4 \pm 0.3\text{mm}$.
2. The thickness of the cover glass is 0.8mm , and the refractive index is 1.5 .

PACKAGE STRUCTURE

PACKAGE MATERIAL	Ceramic
LEAD TREATMENT	GOLD PLATING
LEAD MATERIAL	42ALLOY
PACKAGE WEIGHT	5.8g