

XC2151

Series

ICs for use with Crystal Oscillators



- ◆ **CMOS** : Low Supply Current
- ◆ **Oscillator Frequency** : 4MHz ~ 70MHz
- ◆ **Built-In Oscillator Capacitors**
- ◆ **Divider Ratio** : $f_0/1, f_0/2, f_0/4, f_0/8$
- ◆ **3-State Output**
- ◆ **Supply Voltage** : 5.0V
- ◆ **Mini Mold SOT-26 Package**

Applications

- Crystal Oscillator Modules
- Communication Equipment
- Microcomputers
- Clock Units in Motor Control
- System Clocks on Boards
- Timers
- Palmtops

General Description

The XC2151 series are a group of high frequency, CMOS low power crystal oscillators with oscillator & divider circuitry, oscillator capacitors and amplifier feedback resistors built-in.

An oscillator circuit can be created from just an external crystal.

Output frequency can be selected from four frequencies :

Fundamental $f_0/1$, Divided $f_0/2, f_0/4, f_0/8$.

The output buffer is 3-State and has a fanout of 10 - TTL.

Features

- High Precision** : Built-in oscillator capacitors
16pF TYP (or selectable from 10 ~ 20pF)
: On-chip amplifier feedback resistor
5M Ω TYP (or selectable from 1.6k Ω ~ 8.4k Ω)
- Oscillator Frequency** : 4MHz ~ 70MHz
- Divider Ratio** : Selectable from $f_0/1, f_0/2, f_0/4, f_0/8$
- Output** : 3-State, 10 - TTL fanout
- Operating Voltage Range** : 4.0V ~ 6.0V
- Small Quiescent Current Stand-By Function**
- Low Cost** : Oscillator circuit can be created from just an external crystal
- Ultra Small Package** : SOT-26 (150mW) mini mold

Pin Configuration

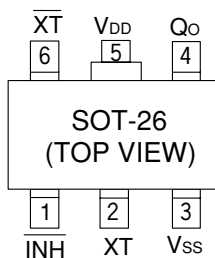

Pin Assignment

PIN NUMBER	PIN NAME	FUNCTION
1	/INH	Control *
2	XT	Oscillator Connection (Input)
3	Vss	GND
4	Qo	Output
5	VDD	Power Supply
6	/XT	Oscillator Connection (Output)

* Control pin has pull-up resistor built-in.

INH, Qo Pin Function

XC2151x51

/INH	Q0
"H"	Output
"L"	High Impedance (oscillator stopped)
open	Output

XC2151x55

/INH	Q0
"H"	Output
"L"	High Impedance (oscillator stopped)
open	Output

"H" = High Level
"L" = Low Level

Product Classification

Ordering Information

X C 2 1 5 1 X X X X X X
 ↑ ↑ ↑ ↑ ↑ ↑ ↑ ↑
 a b c d e f g h

DESIGNATOR	DESCRIPTION	DESIGNATOR	DESCRIPTION
a	Supply Voltage : 5 = 5.0V	e	Stand-by Mode and Divider Ratio : 1=f0/1 (CE), 2=f0/2 (CE), 4=f0/4 (CE), 8=f0/8 (CE), 5=f0/1 (OE)
b	Product Series : 1 = Large output capability, fundamental & overtone	f	Fundamental / Overtone Rf, Cg, Cd : (please refer to electrical characteristics tables)
c	Duty Level : A = CMOS (V _{DD} /2) & TTL C = CMOS (V _{DD} /2) T = TTL	g	Package : M = SOT-26
d	Output Capability : 5 = 10TTL	h	Device Orientation : R= Embossed Tape (Standard Feed) L= Embossed Tape (Reverse Feed)

Marking

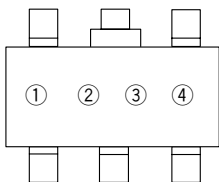

SOT-26
(TOP VIEW)

① Represents the Divider Ratio

MARK	RATIO	MARK	RATIO
A	f0/1	C	f0/4
B	f0/2	D	f0/8

② Represents Stand-by Mode, Duty Level & Output Capability

MARK	STAND-BY MODE	DUTY LEVEL	OUTPUT CAPABILITY
5	CE	CMOS (V _{DD} /2), TTL	10TTL
6	CE	CMOS (V _{DD} /2)	10TTL
7	CE	TTL	10TTL
8	OE	XC2151T=TTL , XC2151C=CMOS	10TTL

③ Represents Fundamental / Overtone and Rf, Cg, Cd

④ Represents the Assembly Lot No.
(based on internal standards)

Block Diagram

1) XC2151A Series

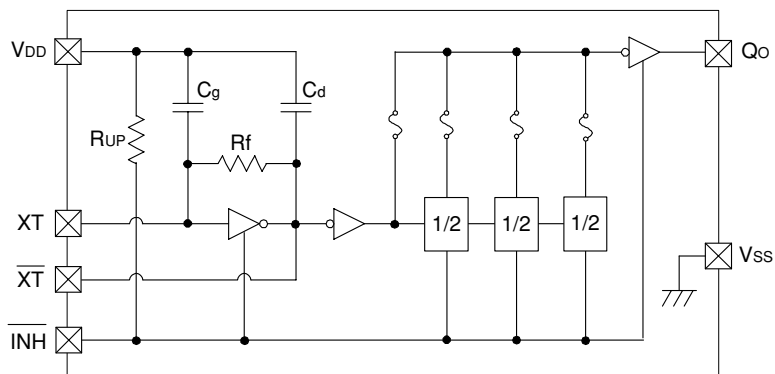

2) XC2151T/C Series

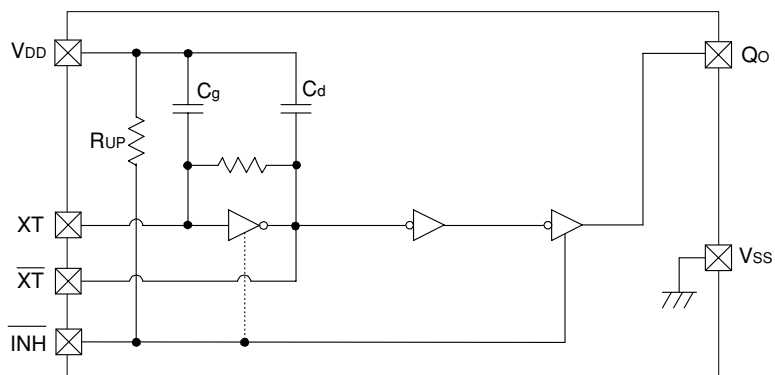

Absolute Maximum Ratings

PARAMETER	SYMBOL	CONDITIONS	UNITS
Supply Voltage	VDD	VSS - 0.3 ~ VSS + 7.0	V
Input Voltage	VIN	VSS - 0.3 ~ VDD + 0.3	V
Power Dissipation	Pd	150	mW
Operating Ambient Temp.	Topr	-30 ~ +75	°C
Storage Temp.	Tstg	-55 ~ +125	°C

Electrical Characteristics

XC2151T51A / 55A (overtone)

V_{DD}=5.0V, Fosc=20MHz, No Load, Ta = 25°C

PARAMETER	SYMBOL	CONDITIONS	MIN	TYP	MAX	UNITS
Operating Supply Voltage	V _{DD}		4.0		6.0	V
Input Voltage 'High'	V _{IH}		2.4			V
Input Voltage 'Low'	V _{IL}				0.4	V
Output Current 'High'	I _{OH}	V _{OH} = 4.6V		- 10		mA
Output Current 'Low'	I _{OL}	V _{OL} = 0.4V	16			mA
Supply Current 1	I _{DD1}	/ INH = OPEN, Q ₀ = OPEN		18	25	mA
Supply Current 2 (51A)	I _{DD2}	/ INH = "L"		2	5	μA
Supply Current 2 (55A)	I _{DD2}	/ INH = "L"		16	23	mA
Input Pull-Up Resistance	R _{UP}	/ INH = 4.5V	50		200	kΩ
Internal Oscillator Capacitance	C _g ,C _d	see note below	18	20	22	pF
Internal Oscillator Feedback Resistance	R _f		5.0	5.5	6.1	kΩ
Output Disable Leakage Current	I _{OZ}	/ INH = "L"			10	μA

note : the values for C_g,C_d are the designed values.

XC2151T51D / 55D (overtone)

V_{DD}=5.0V, Fosc=70MHz, No Load, Ta = 25°C

PARAMETER	SYMBOL	CONDITIONS	MIN	TYP	MAX	UNITS
Operating Supply Voltage	V _{DD}		4.0		6.0	V
Input Voltage 'High'	V _{IH}		2.4			V
Input Voltage 'Low'	V _{IL}				0.4	V
Output Current 'High'	I _{OH}	V _{OH} = 4.6V		- 10		mA
Output Current 'Low'	I _{OL}	V _{OL} = 0.4V	16			mA
Supply Current 1	I _{DD1}	/ INH = OPEN, Q ₀ = OPEN		25	35	mA
Supply Current 2 (51D)	I _{DD2}	/ INH = "L"		2	5	μA
Supply Current 2 (55D)	I _{DD2}	/ INH = "L"		23	32	mA
Input Pull-Up Resistance	R _{UP}	/ INH = 4.5V	50		200	kΩ
Internal Oscillator Capacitance	C _g ,C _d	see note below	9	10	11	pF
Internal Oscillator Feedback Resistance	R _f		2.7	3.0	3.3	kΩ
Output Disable Leakage Current	I _{OZ}	/ INH = "L"			10	μA

note : the values for C_g,C_d are the designed values.

XC2151T (overtone)

PART No.	DUTY LEVEL	OUTPUT	DIVIDER RATIO	R _f (kΩ)	C _g /C _d (pF)	RECOMMENDED FREQUENCY RANGE
XC2151T51A	TTL	10TTL	f ₀ / 1	5.5	20	20MHz to 33MHz
XC2151T51B	TTL	10TTL	f ₀ / 1	4.0	20	30MHz to 45MHz
XC2151T51C	TTL	10TTL	f ₀ / 1	3.0	13	43MHz to 57MHz
XC2151T51D	TTL	10TTL	f ₀ / 1	3.0	10	55MHz to 70MHz

XC2151C51F / 55F (overtone)

VDD=5.0V, Fosc=20MHz, No Load, Ta = 25°C

PARAMETER	SYMBOL	CONDITIONS	MIN	TYP	MAX	UNITS
Operating Supply Voltage	VDD		4.0		6.0	V
Input Voltage 'High'	VIH		2.4			V
Input Voltage 'Low'	VIL				0.4	V
Output Current 'High'	IOH	VOH = 4.6V		- 10		mA
Output Current 'Low'	IOL	VOL = 0.4V	16			mA
Supply Current 1	IDD1	/ INH = OPEN, Q0 = OPEN		18	25	mA
Supply Current 2 (51F)	IDD2	/ INH = "L"		2	5	μA
Supply Current 2 (55F)	IDD2	/ INH = "L"		16	23	mA
Input Pull-Up Resistance	RUP	/ INH = 4.5V	50		200	kΩ
Internal Oscillator Capacitance	Cg,Cd	see note below	18	20	22	pF
Internal Oscillator Feedback Resistance	Rf		5.0	5.5	6.1	kΩ
Output Disable Leakage Current	IOZ	/ INH = "L"			10	μA

note : the values for Cg,Cd are the designed values.

XC2151C51L / 55L (overtone)

VDD=5.0V, Fosc=70MHz, No Load, Ta = 25°C

PARAMETER	SYMBOL	CONDITIONS	MIN	TYP	MAX	UNITS
Operating Supply Voltage	VDD		4.0		6.0	V
Input Voltage 'High'	VIH		2.4			V
Input Voltage 'Low'	VIL				0.4	V
Output Current 'High'	IOH	VOH = 4.6V		- 10		mA
Output Current 'Low'	IOL	VOL = 0.4V	16			mA
Supply Current 1	IDD1	/ INH = OPEN, Q0 = OPEN		25	35	mA
Supply Current 2 (51L)	IDD2	/ INH = "L"		2	5	μA
Supply Current 2 (55L)	IDD2	/ INH = "L"		23	32	mA
Input Pull-Up Resistance	RUP	/ INH = 4.5V	50		200	kΩ
Internal Oscillator Capacitance	Cg,Cd	see note below	9	10	11	pF
Internal Oscillator Feedback Resistance	Rf		2.7	3.0	3.3	kΩ
Output Disable Leakage Current	IOZ	/ INH = "L"			10	μA

note : the values for Cg,Cd are the designed values.

XC2151C (overtone)

PART No.	DUTY LEVEL	OUTPUT	DIVIDER RATIO	Rf (k Ω)	Cg/Cd (pF)	RECOMMENDED
XC2151C51F	CMOS (VDD/2)	10TTL	f0 / 1	5.5	20	20MHz to 33MHz
XC2151C51H	CMOS (VDD/2)	10TTL	f0 / 1	4.0	20	30MHz to 45MHz
XC2151C51K	CMOS (VDD/2)	10TTL	f0 / 1	3.0	13	43MHz to 57MHz
XC2151C51L	CMOS (VDD/2)	10TTL	f0 / 1	3.0	10	55MHz to 70MHz

XC2151A510 / 519 (fundamental)

VDD=5.0V, Fosc=20MHz, No Load, Ta = 25°C

PARAMETER	SYMBOL	CONDITIONS	MIN	TYP	MAX	UNITS
Operating Supply Voltage	VDD		4.0		6.0	V
Input Voltage 'High'	VIH		2.4			V
Input Voltage 'Low'	VIL				0.4	V
Output Current 'High'	IOH	VOH = 4.6V		- 10		mA
Output Current 'Low'	IOL	VOL = 0.4V	16			mA
Supply Current 1	IDD1	/ INH = OPEN, Q0 = OPEN			12	mA
Supply Current 2	IDD2	/ INH = "L"		2	5	μA
Input Pull-Up Resistance	RUP	/ INH = 4.5V	50		200	kΩ
Internal Oscillator Capacitance	Cg,Cd	see note below		16		pF
Internal Oscillator Feedback Resistance	Rf			5		MΩ
Output Disable Leakage Current	IOZ				10	μA

note : the values for Cg,Cd are the designed values with XC2151A510. The XC2151A519 is an external type.

XC2151A580 / 589 (fundamental, f0 / 8)

VDD=5.0V, Fosc=20MHz, No Load, Ta = 25°C

PARAMETER	SYMBOL	CONDITIONS	MIN	TYP	MAX	UNITS
Operating Supply Voltage	VDD		4.0		6.0	V
Input Voltage 'High'	VIH		2.4			V
Input Voltage 'Low'	VIL				0.4	V
Output Current 'High'	IOH	VOH = 4.6V		- 10		mA
Output Current 'Low'	IOL	VOL = 0.4V	16			mA
Supply Current 1	IDD1	/ INH = OPEN, Q0 = OPEN			12	mA
Supply Current 2	IDD2	/ INH = "L"		2	5	μA
Input Pull-Up Resistance	RUP	/ INH = 4.5V	50		200	kΩ
Internal Oscillator Capacitance	Cg,Cd	see note below		16		pF
Internal Oscillator Feedback Resistance	Rf			5		MΩ
Output Disable Leakage Current	IOZ				10	μA

note : the values for Cg,Cd are the designed values with XC2151A580. The XC2151A589 is an external type.

XC2151A (fundamental)

PART No.	DUTY LEVEL	OUTPUT	DIVIDER RATIO	Rf (M Ω)	Cg/Cd (pF)	RECOMMENDED FREQUENCY RANGE
XC2151A510	CMOS (VDD/2), TTL	10TTL	f0 / 1	5.0	16	4MHz to 30MHz
XC2151A520	CMOS (VDD/2), TTL	10TTL	f0 / 2	5.0	16	4MHz to 30MHz
XC2151A540	CMOS (VDD/2), TTL	10TTL	f0 / 4	5.0	16	4MHz to 30MHz
XC2151A580	CMOS (VDD/2), TTL	10TTL	f0 / 8	5.0	16	4MHz to 30MHz
XC2151A519	CMOS (VDD/2), TTL	10TTL	f0 / 1	5.0	16 (ext.)	4MHz to 30MHz
XC2151A529	CMOS (VDD/2), TTL	10TTL	f0 / 2	5.0	16 (ext.)	4MHz to 30MHz
XC2151A549	CMOS (VDD/2), TTL	10TTL	f0 / 4	5.0	16 (ext.)	4MHz to 30MHz
XC2151A589	CMOS (VDD/2), TTL	10TTL	f0 / 8	5.0	16 (ext.)	4MHz to 30MHz

Switching Characteristics

XC2151T (overtone, fundamental)

TTL Duty, $V_{DD}=5.0V$, $T_a = 25^\circ C$

PARAMETER	SYMBOL	CONDITIONS	MIN	TYP	MAX	UNITS
Output Rise Time	T_{TLH}	Load=10TTL, 0.4V→2.4V			5	nsec
Output Fall Time	T_{THL}	Load=10TTL, 2.4V→0.4V			5	nsec
Duty Cycle	DUTY	Load=10TTL @ 1.4V	45		55	%

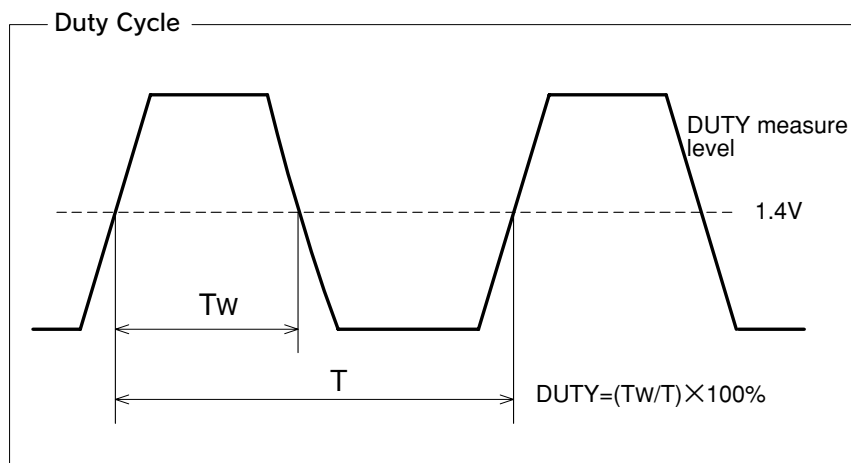
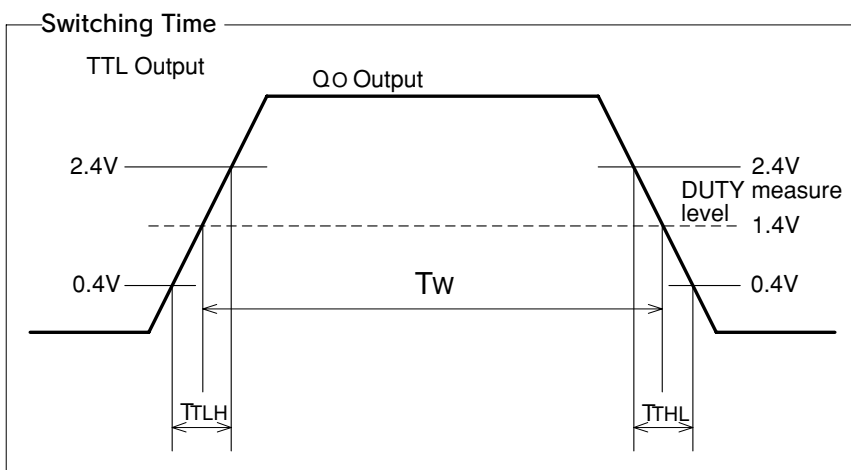

XC2151C (overtone, fundamental)

TTL Duty, $V_{DD}=5.0V$, $T_a = 25^\circ C$

PARAMETER	SYMBOL	CONDITIONS	MIN	TYP	MAX	UNITS
Output Rise Time	T _{TLH}	$C_L=15pF, 0.1V_{DD} \rightarrow 0.9V_{DD}$			5	nsec
Output Fall Time	T _{THL}	$C_L=15pF, 0.9V_{DD} \rightarrow 0.1V_{DD}$			5	nsec
Duty Cycle	DUTY	$C_L=15pF @ V_{DD}/2$	45		55	%

