

PRELIMINARY - August 7, 2000

TEL:805-498-2111 FAX:805-498-3804 WEB:http://www.semtech.com

## DESCRIPTION

The SC1452 is a state of the art device intended to provide maximum performance and flexibility in battery operated systems. It has been designed specifically to fully support a single Li-Ion battery and its external charger voltages.

The SC1452 contains two independently enabled, ultra low dropout voltage regulators (ULDOs). It operates from an input voltage range of 2.5V to 6.5V, and a wide variety of output voltage options are available which are designed to provide an initial tolerance of  $\pm 1\%$  and  $\pm 2\%$  over temperature.

Each regulator has an associated active-low reset signal which is asserted when the voltage output declines below the preset threshold. Once the output recovers, the reset continues to be asserted (delayed) for a predetermined time, 50ms for reset A and 150ms for reset B. In the case of regulator B, the delay time may be reduced by the addition of an external capacitor.

The SC1452 has a bypass pin to enable the user to capacitively decouple the bandgap reference for very low output noise (down to  $50\mu\text{Vrms}$ ).

The devices utilize CMOS technology to achieve very low operating currents (typically  $150\mu\text{A}$  with both outputs supplying  $150\text{mA}$ ). The dropout voltage is typically  $165\text{mV}$  at  $150\text{mA}$ , helping to prolong battery life. In addition, the devices are guaranteed to provide  $400\text{mA}$  of peak current for applications which require high initial inrush current. They have been designed to be used with low ESR ceramic capacitors to save cost and PCB area.

The SC1452 comes in the low profile 10-lead MSOP package.

## TYPICAL APPLICATION

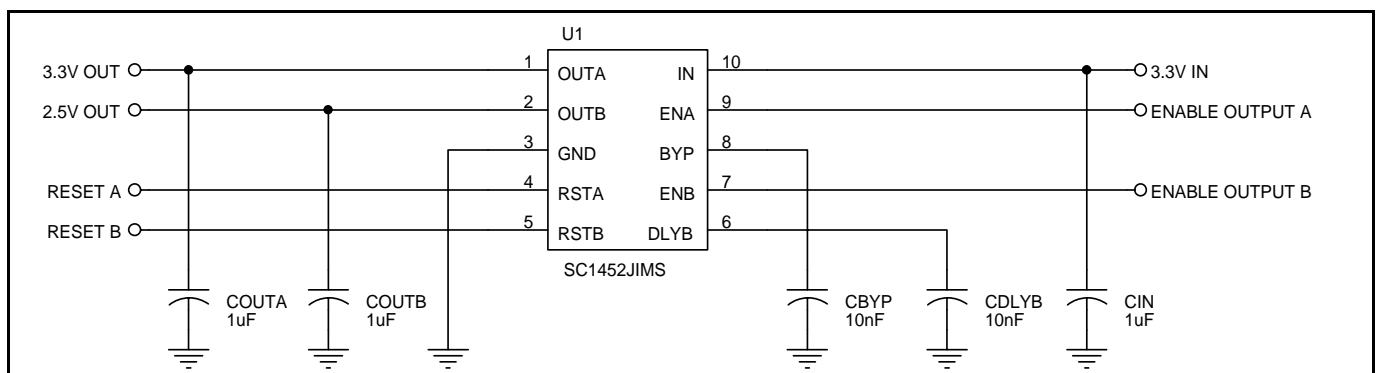

## FEATURES

- Up to 150mA per regulator output
- Low quiescent current
- Low dropout voltage
- Wide selection of output voltages
- Stable operation with ceramic caps
- Tight load and line regulation
- Current and thermal limiting
- Reverse input polarity protection
- $<1\mu\text{A}$  off-mode current
- Logic controlled electronic enable
- Programmable reset
- Full industrial temperature range

## APPLICATIONS

- Cellular telephones
- Palmtop/Laptop computers
- Battery-powered equipment
- Bar code scanners
- SMPS post regulator/dc to dc modules
- High efficiency linear power supplies

## ORDERING INFORMATION

Part Numbers	Package
SC1452XIMSTR <sup>(1)(2)</sup>	MSOP-10

Notes:

- (1) Where X denotes voltage options - see table on page 5.
- (2) Only available in tape and reel packaging. A reel contains 2500 devices.

PRELIMINARY - August 7, 2000

**ABSOLUTE MAXIMUM RATINGS**

Parameter	Symbol	Maximum	Units
Input Supply Voltage	$V_{IN}$	-5 to +7	V
Enable Input Voltage	$V_{EN}$	-5 to + $V_{IN}$	V
Operating Ambient Temperature Range	$T_A$	-40 to +85	°C
Operating Junction Temperature Range	$T_J$	-40 to +125	°C
Storage Temperature	$T_{STG}$	-60 to +150	°C
Thermal Resistance Junction to Ambient	$\theta_{JA}$	113	°C/W
Thermal Resistance Junction to Case	$\theta_{JC}$	42	°C/W
ESD Rating (Human Body Model)	ESD	2	kV

**ELECTRICAL CHARACTERISTICS**

 Unless specified:  $T_A = 25^\circ\text{C}$ ,  $V_{IN} = V_{OUT} + 1\text{V}$ ,  $I_{OUTA} = I_{OUTB} = 1\text{mA}$ ,  $C_{OUT} = 1.0\ \mu\text{F}$ ,  $V_{ENA} = V_{ENB} = V_{IN}$ . Values in **bold** apply over full operating temperature range.

Parameter	Symbol	Condition	Min	Typ	Max	Units
<b>IN</b>						
Input Supply Voltage	$V_{IN}$		<b>2.5</b>		<b>6.5</b>	V
Quiescent Current	$I_Q$	$V_{ENA} = 0\text{V}$ , $V_{ENB} = V_{IN}$ , $I_{OUTB} = 150\text{mA}$ or $V_{ENB} = 0\text{V}$ , $V_{ENA} = V_{IN}$ , $I_{OUTA} = 150\text{mA}$		90	150	$\mu\text{A}$
		$V_{ENA} = V_{ENB} = V_{IN}$ , $I_{OUTA} = I_{OUTB} = 150\text{mA}$		150	240	$\mu\text{A}$
		$V_{ENA} = V_{ENB} = 0\text{V (OFF)}$		0.5	1	$\mu\text{A}$
<b>OUTA, OUTB</b>						
Output Voltage	$V_{OUT}$	$I_{OUT} = 1\text{mA}$	-1%	$V_{OUT}$	+1%	V
		$0\text{mA} \leq I_{OUT} \leq 150\text{mA}$ , $V_{OUT} + 1\text{V} \leq V_{IN} \leq 5.5\text{V}$	<b>-2%</b>		<b>+2%</b>	
Line Regulation	$REG_{(LINE)}$	$V_{OUT} + 1\text{V} \leq V_{IN} \leq 5.5\text{V}$ , $I_{OUT} = 1\text{mA}$		5	10	mV
					<b>12</b>	
Load Regulation	$REG_{(LOAD)}$	$0.1\text{mA} \leq I_{OUT} \leq 150\text{mA}$		-5	-15	mV
					<b>-30</b>	
Dropout Voltage	$V_D$	$I_{OUT} = 1\text{mA}$		1.1		mV
		$I_{OUT} = 50\text{mA}$		55	75	mV
		$I_{OUT} = 150\text{mA}$		165	250	mV
					<b>300</b>	
Current Limit	$I_{LIM}$		<b>400</b>			mA

PRELIMINARY - August 7, 2000

**ELECTRICAL CHARACTERISTICS (Cont.)**

 Unless specified:  $T_A = 25^\circ\text{C}$ ,  $V_{IN} = V_{OUT} + 1\text{V}$ ,  $I_{OUTA} = I_{OUTB} = 1\text{mA}$ ,  $C_{OUT} = 1.0\ \mu\text{F}$ ,  $V_{ENA} = V_{ENB} = V_{IN}$ . Values in **bold** apply over full operating temperature range.

Parameter	Symbol	Condition	Min	Typ	Max	Units
<b>OUTA, OUTB (Cont.)</b>						
Ripple Rejection	PSRR	$f = 120\text{Hz}$ , $C_{BYP} = 10\text{nF}$		60		dB
Output Voltage Noise	$e_n$	$f = 10\text{Hz to } 99\text{kHz}$ , $I_{OUT} = 50\text{mA}$ , $C_{BYP} = 10\text{nF}$ , $C_{OUT} = 2.2\ \mu\text{F}$		50		$\mu\text{V}_{\text{RMS}}$
<b>BYP</b>						
Start-up Rise Time	$t_r$	$C_{BYP} = 10\text{nF}$		1.5		ms
<b>ENABLE (ENA, ENB)</b>						
Enable Input Threshold	$V_{IH}$		<b>1.6</b>			V
	$V_{IL}$				<b>0.4</b>	
Enable Input Current	$I_{EN}$				<b>0.2</b>	$\mu\text{A}$
<b>RSTA, RSTB</b>						
Reset Threshold	$V_{TH}$	$V_{OUT}$ falling	<b>88</b>	90	<b>92</b>	% $V_{OUT}$
		$V_{OUT}$ rising	<b>90</b>	92	<b>94</b>	
Reset A Delay	$t_{RSTA}$		<b>30</b>	50	<b>70</b>	ms
Reset B Delay	$t_{RSTB}$	$V_{DLYB} = 0\text{V}$	<b>90</b>	150	<b>210</b>	ms
Reset A, B Output Voltage <sup>(1)</sup>	$V_{OH}$	$I_{SOURCE} = 0.5\text{mA}$	<b>80</b>			% $V_{OUT}$
	$V_{OL}$	$I_{SINK} = 1.2\text{mA}$			<b>0.3</b>	V
<b>DLYB</b>						
Delay Voltage Threshold	$V_{DLYB}$		<b>1.225</b>	1.250	<b>1.275</b>	V
Delay Source Current	$I_{DLYB}$	$V_{OUTB} < V_{TH}$	<b>2.1</b>	3.0	<b>3.9</b>	$\mu\text{A}$
<b>OVER TEMPERATURE PROTECTION</b>						
High Trip Level	$T_{HI}$			150		$^\circ\text{C}$
Hysteresis	$T_{HYST}$			20		$^\circ\text{C}$

**NOTE:**

 (1)  $V_{OHA}$  will be a percentage of  $V_{OUTA}$ , and  $V_{OHB}$  will be a percentage of  $V_{OUTB}$ .

PRELIMINARY - August 7, 2000

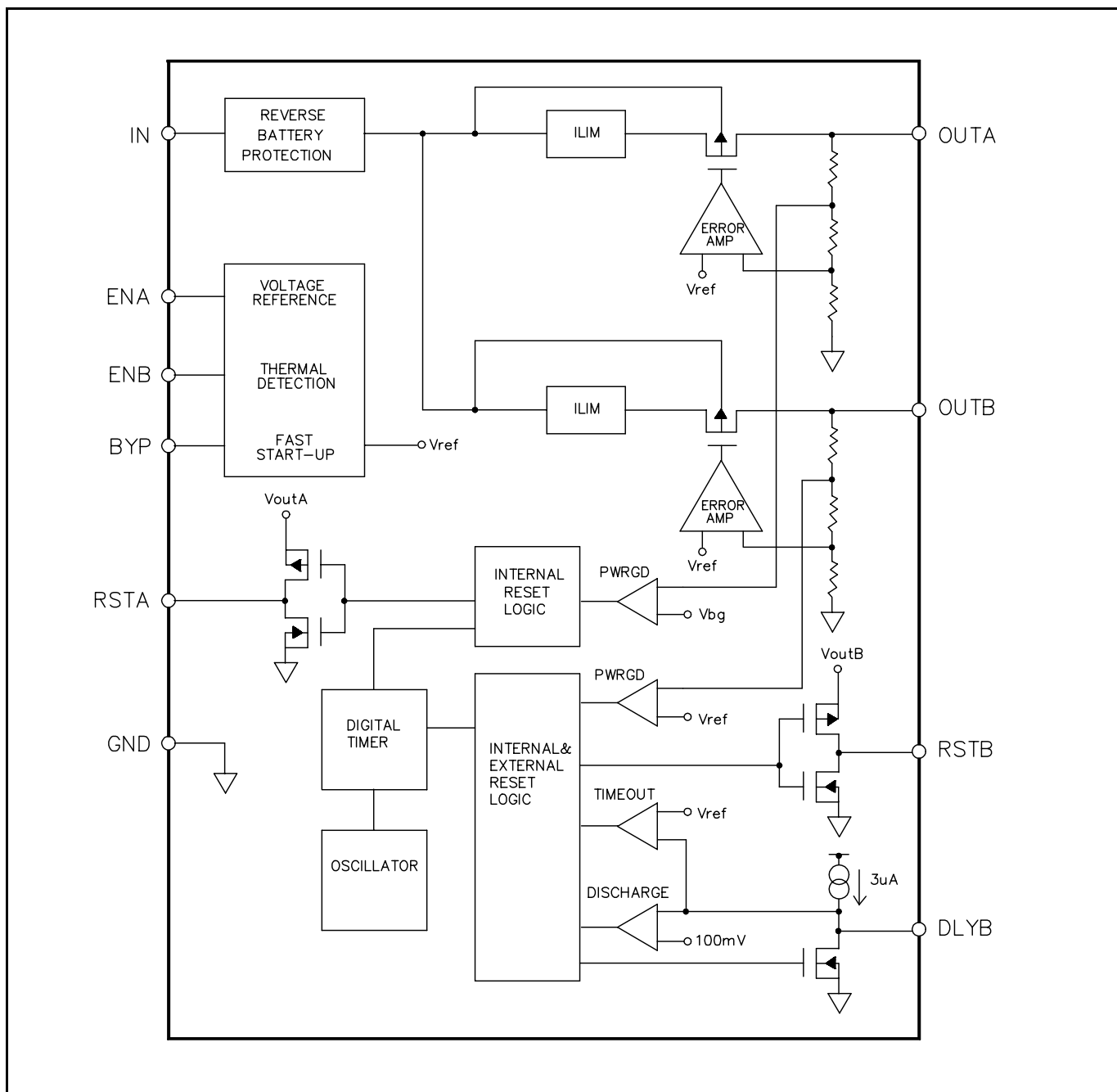
**BLOCK DIAGRAM**

PRELIMINARY - August 7, 2000

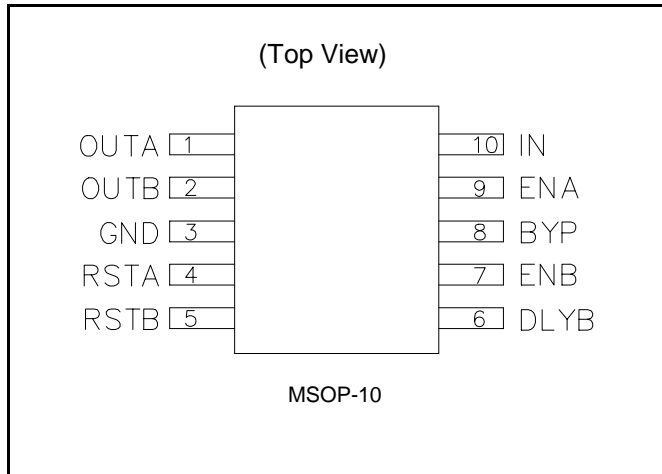
**PIN CONFIGURATION**

**VOLTAGE OPTIONS**

Replace X in the part number (SC1452XIMS) by the letter shown below for the corresponding voltage option:

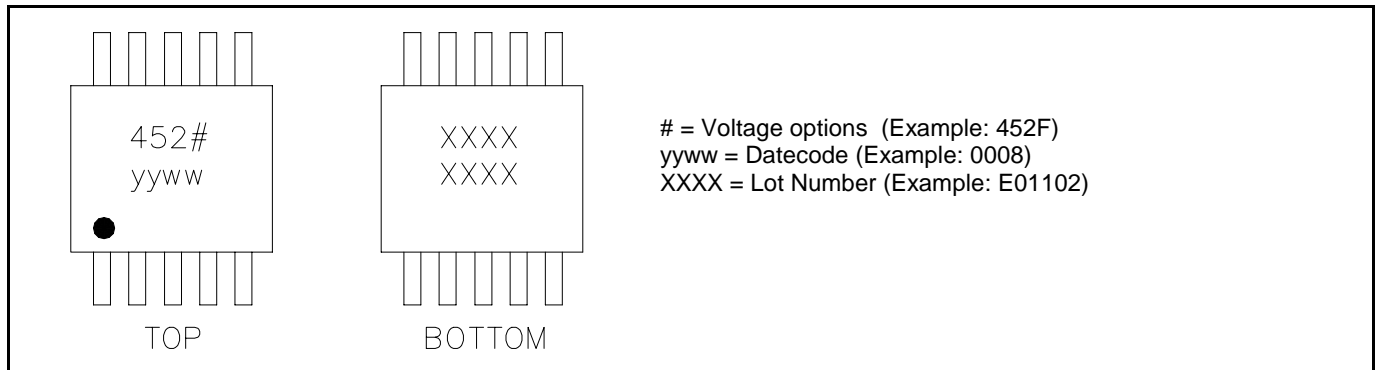
X	V <sub>OUTA</sub> (V)	V <sub>OUTB</sub> (V)
A	1.8	1.8
B	2.5	2.5
C	2.8	2.8
D	3.0	3.0
E	3.3	3.3
F	3.0	2.5
G	3.0	1.8
H	3.0	2.8
J	3.3	2.5
K	3.3	2.8

**MARKING INFORMATION**

**PIN DESCRIPTIONS**

Pin #	Pin Name	Pin Function
1	OUTA	Regulator A output.
2	OUTB	Regulator B output.
3	GND	Ground pin.
4	RSTA	Power on reset for regulator A. Active low when OUTA is below the reset threshold.
5	RSTB	Power on reset for regulator B. Active low when OUTB is below the reset threshold.
6	DLYB	Programmable delay for RESETB. Delay time can be set by connecting a capacitor, C <sub>DLYB</sub> , between this pin and ground. Ground this pin if using the default delay time.
7	ENB	Active high enable pin for output B. CMOS compatible input. Connect to IN if not being used.
8	BYP	Bypass pin for bandgap reference. Connect a 10nF capacitor, C <sub>BYP</sub> , between this pin and ground for low noise operation.
9	ENA	Active high enable pin for output A. CMOS compatible input. Connect to IN if not being used.
10	IN	Input pin for both regulators.

PRELIMINARY - August 7, 2000

## APPLICATIONS INFORMATION

### Adjusting RSTB Delay Time

RSTB, the power on reset for regulator B, can be *reduced* externally by connecting a capacitor to the delay time set pin DLYB. If DLYB is connected to ground, the internally controlled delay time of 150ms (typ.) will apply.

Referring to the block diagram, as the output of regulator B ( $V_{OUTB}$ ) rises and reaches the reset threshold voltage ( $92\% V_{OUTB(NOM)}$ ), two things happen:

- 1) the internal 150ms timer starts;
- 2) the  $3\mu A$  current source turns on, charging  $C_{DLYB}$  (if connected).

If DLYB is connected to ground, RSTB goes high 150ms after  $V_{OUTB}$  crosses the threshold voltage. If a capacitor is connected between DLYB and ground, the voltage at DLYB can be described by the following equation:

$$V_{DLYB} = \frac{3 \cdot 10^{-6} \cdot t}{C_{DLYB}}$$

An internal comparator compares this voltage to a 1.25V reference, and triggers the reset high once this

voltage is reached. The delay time can be calculated by rearranging the above equation, solving for t:

$$t_{RSTB} = \frac{C_{DLYB} \cdot 1.25}{3 \cdot 10^{-6}} = 416,667 \cdot C_{DLYB}$$

Note that the *maximum* delay time is 150ms, as RSTB goes high when either the internal timer or externally set timer times out, so if  $t_{RSTB}$  is set externally for 200ms, the reset delay will still be 150ms. Thus for a 150ms delay,  $C_{DLYB}$  should be grounded, and for a delay time *less* than 150ms,  $C_{DLYB}$  can be calculated using the equation above, or read from the chart below.

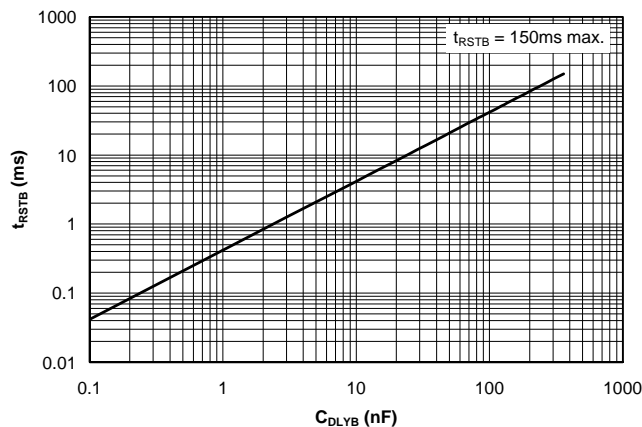

PRELIMINARY - August 7, 2000

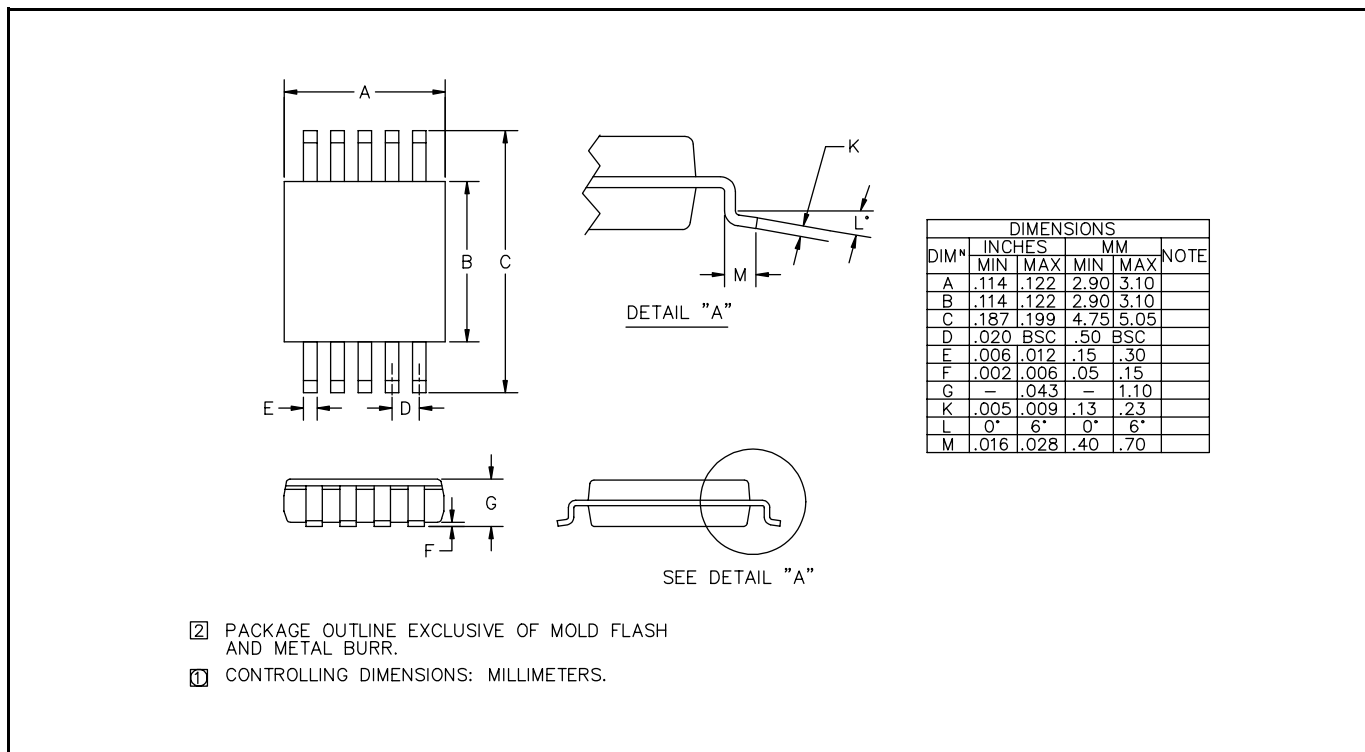
**DEVICE OUTLINE - MSOP-10**

**LAND PATTERN - MSOP- 10 - DRAWING PENDING**

ECN 00-1247