



MOTOROLA

Product Preview

Time slot interchange circuit

The MC145601 Time Slot Interchange Circuit (TSIC) is a CMOS IC specially designed for switching Pulse Code Modulation (PCM) voice or data, under microprocessor control, in a digital exchange or central office. It connects any of 256 incoming PCM channels to any 256 outgoing channels.

Features:

- Single 5 Volt supply
- 8 x 32 input channels
- 8 x 32 output channels
- Built in time slot assigner
- 256 ports nonblocking digital switching matrix
- 8 instructions available
- Expandable to larger capacity block
- 32 serial channels per frame
- Typical bit rate: 2.048 Mbit/s
- Typical synchronization rate: 8KHz
- Interface to MC68XXX family microprocessors
- Building block for digital PABX
- 40 pin dual in line package

MC145601

**SILICON GATE
CMOS**

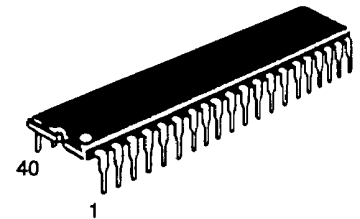

P suffix
Plastic package
Case 711

PIN ASSIGNMENT

OC4	1	40	RESET
OC3	2	39	CLOCK
OC2	3	38	SYNC
OC1	4	37	TX7
OC0	5	36	TX6
RX7	6	35	TX5
RX6	7	34	TX4
RX5	8	33	VDD
RX4	9	32	TX3
VSS	10	31	TX2
RX3	11	30	TX1
RX2	12	29	TX0
RX1	13	28	D7
RX0	14	27	D6
READY	15	26	D5
DTACK	16	25	D4
RS1	17	24	D3
RS0	18	23	D2
R/W	19	22	D1
CS	20	21	D0

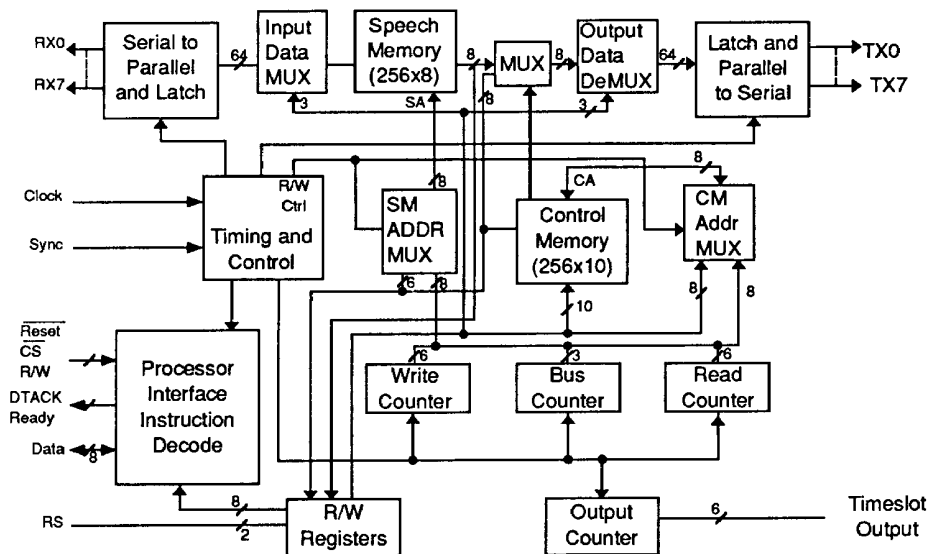

Block Diagram