HD66100F

(LCD Driver with 80-Channel Outputs)

HITACHI

Description

The HD66100F description segment driver with 80 LCD drive circuits is the improved version of the no longer current HD44100H LCD driver with 40 circuits.

It is composed of a shift register, an 80-bit latch circuit, and 80 LCD drive circuits. Its interface is compatible with the HD44100H. It reduces the number of LSI's and lowers the cost of an LCD module.

Features

- LCD driver with serial/parallel converting function
- Interface compatible with the HD44100H; connectable with HD43160AH, HD61830, HD61830B, LCD-II (HD44780), LCD-III (HD44790)
- Internal output circuits for LCD drive: 80
- Internal serial/parallel converting circuits
 - 80-bit bidirectional shift register
 - 80-bit latch circuit
- Power supply
 - Internal logic circuit: +5V \pm 10%
 - LCD drive circuit: 3.0V to 6.0V
- CMOS process

HD66100F

Comparison with HD44100H

Table 1 shows the main differences between HD66100F and HD44100H.

Table 1 **Difference between Products HD66100F and HD44100H**

	HD66100F	HD44100H
LCD drive outputs	80 × 1 channel	20 × 2 channels
Supply voltage for LCD drive circuits	3 to 6V	4.5 to 11V
Multiplexing duty ratio	Static to 1/16 duty	Static to 1/32 duty
Package	100-pin plastic QFP	60-pin plastic QFP

Ordering Information

Type No.	Package
HD66100F	100-pin plastic QFP (FP-100)
HD66100FH	100-pin plastic QFP (FP-100B)
HD66100D	Chip

Pad Coordinate

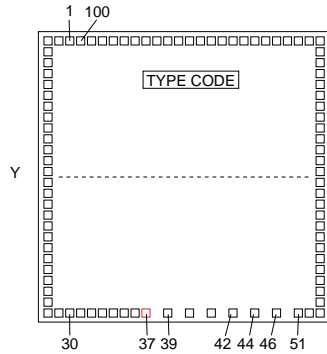

Chip size (X × Y) : 4.50mm × 4.50mm
 Coordinate : Pad Center
 Origin : Chip Center
 Pad size (X × Y) : 100μm × 100μm

Unit : μm

Pad No.	Function	Coordinate	
		X	Y
1	Y30	-1725	2100
2	Y29	-1925	2100
3	Y28	-2100	2060
4	Y27	-2100	1865
5	Y26	-2100	1690
6	Y25	-2100	1520
7	Y24	-2100	1360
8	Y23	-2100	1200
9	Y22	-2100	1040
10	Y21	-2100	880
11	Y20	-2100	720
12	Y19	-2100	560
13	Y18	-2100	400
14	Y17	-2100	240
15	Y16	-2100	80
16	Y15	-2100	-80
17	Y14	-2100	-240
18	Y13	-2100	-400
19	Y12	-2100	-560
20	Y11	-2100	-720
21	Y10	-2100	-880
22	Y9	-2100	-1040
23	Y8	-2100	-1200
24	Y7	-2100	-1360
25	Y6	-2100	-1520
26	Y5	-2100	-1690
27	Y4	-2100	-1865
28	Y3	-2100	-2060
29	Y2	-1925	-2100
30	Y1	-1725	-2100
31	V _{FF}	-1520	-2100
32	V1	-1360	-2100
33	V2	-1200	-2100
34	V3	-1040	-2100

Pad No.	Function	Coordinate	
		X	Y
35	V4	-880	-2100
36	GND	-720	-2100
37	CL1	-470	-2100
38			
39	SHL	-270	-2100
40	CL2	-70	-2100
41	DI	130	-2100
42	DO	350	-2100
43			
44	M	620	-2100
45			
46	V _{CC}	980	-2100
47			
48			
49			
50			
51	Y80	1725	-2100
52	Y79	1925	-2100
53	Y78	2100	-2060
54	Y77	2100	-1865
55	Y76	2100	-1690
56	Y75	2100	-1520
57	Y74	2100	-1360
58	Y73	2100	-1200
59	Y72	2100	-1040
60	Y71	2100	-880
61	Y70	2100	-720
62	Y69	2100	-560
63	Y68	2100	-400
64	Y67	2100	-240
65	Y66	2100	-80
66	Y65	2100	80
67	Y64	2100	240
68	Y63	2100	400

Pad No.	Function	Coordinate	
		X	Y
69	Y62	2100	560
70	Y61	2100	720
71	Y60	2100	880
72	Y59	2100	1040
73	Y58	2100	1200
74	Y57	2100	1360
75	Y56	2100	1520
76	Y55	2100	1690
77	Y54	2100	1865
78	Y53	2100	2060
79	Y52	1925	2100
80	Y51	1725	2100
81	Y50	1520	2100
82	Y49	1360	2100
83	Y48	1200	2100
84	Y47	1040	2100
85	Y46	880	2100
86	Y45	720	2100
87	Y44	560	2100
88	Y43	400	2100
89	Y42	240	2100
90	Y41	80	2100
91	Y40	-80	2100
92	Y39	-240	2100
93	Y38	-400	2100
94	Y37	-560	2100
95	Y36	-720	2100
96	Y35	-880	2100
97	Y34	-1040	2100
98	Y33	-1200	2100
99	Y32	-1360	2100
100	Y31	-1520	2100

HD66100F

Pin Arrangement

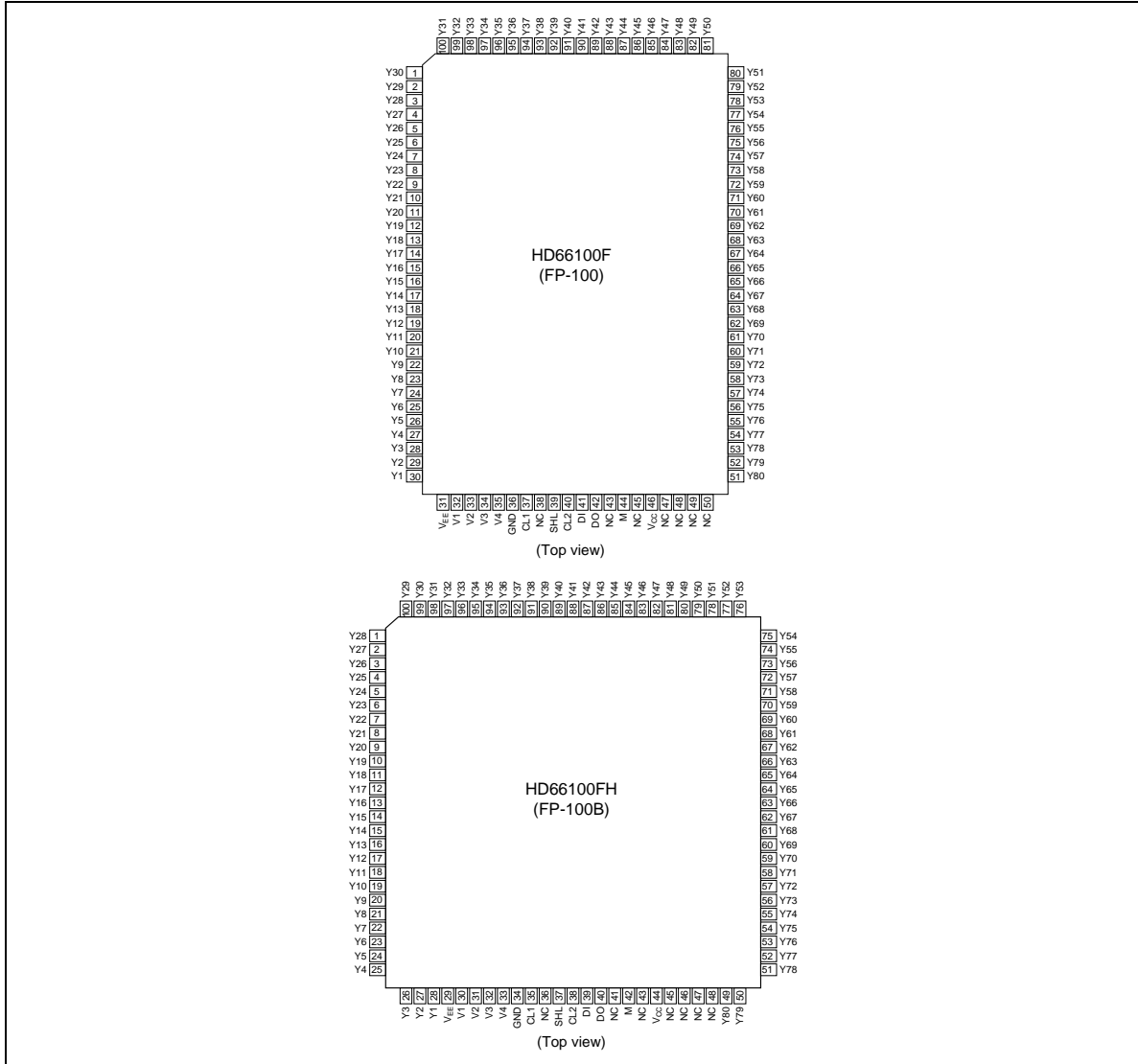

Pin Description

V_{CC}, GND, V_{EE}: V_{CC} supplies power to the internal logic circuit. GND is the logic and drive ground. V_{EE} supplies power to the LCD drive circuit.

V1, V2, V3, and V4: V1 to V4 supply power for driving an LCD (Figure 2).

CL1: HD66100F latches data at the negative edge of CL1.

CL2: HD66100F receives shift data at the negative edge of CL2.

M: Changes LCD drive outputs to AC.

DI: Inputs data to the shift register.

DO: Output data from the shift register.

SHL: Selects a shift direction of serial data. When the serial data is input in order of D1, D2, ..., D79, D80, the relation between the data and the output Y is shown in Table 3.

Y1–Y80: Each Y outputs one of the four voltage levels—V1, V2, V3, or V4—according to the combination of M and display data (Figure 2).

NC: Do not connect any wire to these terminals.

Table 2 Pin Function

Symbol	Pin No.	Pin Name	I/O
V _{CC}	46	V _{CC}	—
GND	36	Ground	—
V _{EE}	31	V _{EE}	—
V1	32	V1	—
V2	33	V2	—
V3	34	V3	—
V4	35	V4	—
CL1	37	Clock 1	I
CL2	40	Clock 2	I
M	44	M	I
DI	41	Data in	I
DO	42	Data out	O
SHL	39	Shift left	I
Y1–Y80	1–30, 51–100	Y1–Y80	O
NC	38, 43, 45, 47–50	No connection	—

HD66100F

Table 3 Relation between SHL and Data Output

SHL	Y1	Y2	Y3.....	Y79	Y80
High	D1	D2	D3.....	D79	D80
Low	D80	D79	D78.....	D2	D1

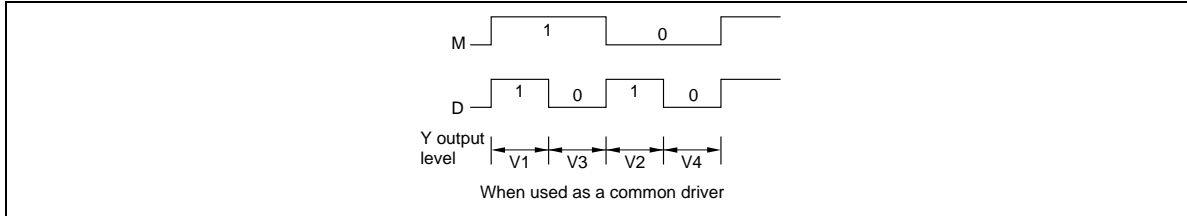

Figure 1 Selection of LCD Drive Output

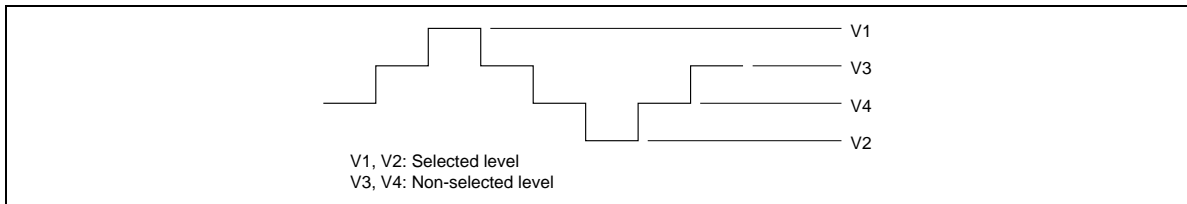

Figure 2 Power Supply for Driving an LCD

Block Functions

LCD Drive Circuits

Select one of four levels of voltage V1, V2, V3, and V4 for driving a LCD and transfer it to the output terminals according to the combination of M and the data in the latch circuit.

Latch Circuit

Latches the data input from the bidirectional shift register at the fall of CL1 and transfer its outputs to the LCD drive circuits.

Bidirectional Shift Register

Shifts the serial data at the fall of CL2 and transfers the output of each bit of the register to the latch circuit. When SHL = GND, the data input from DI shifts from bit 1 to bit 80 in order of entry. On the other hand, when SHL = V_{CC}, the data shifts from bit 80 to bit-1. In both cases, the data of the last bit of the register is latched to be output from DO at the rise of CL2.

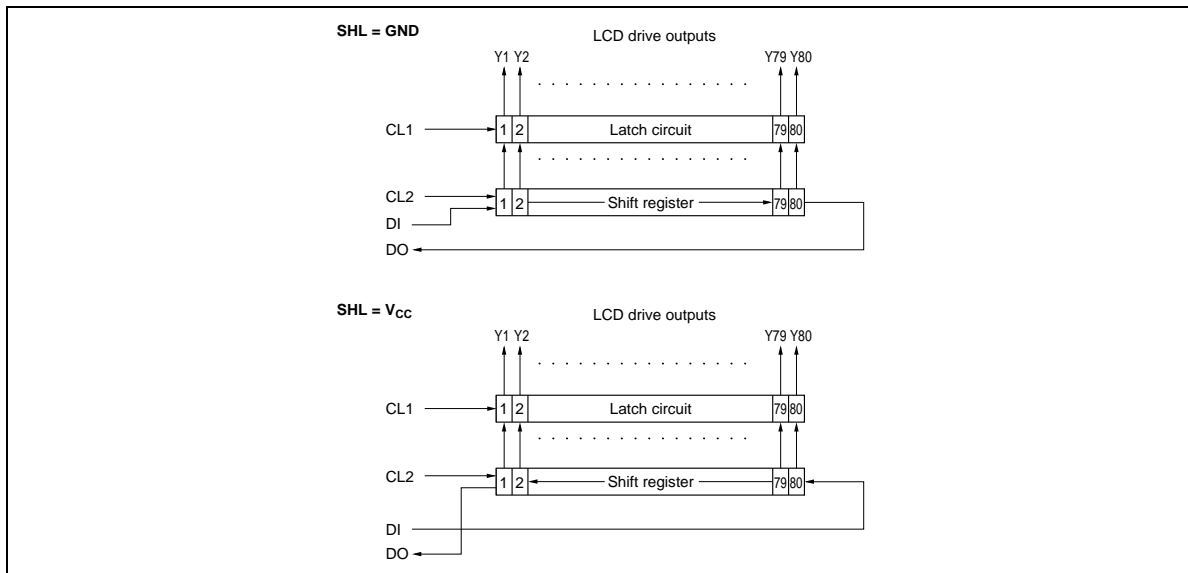

Figure 3 Relation between SHL and the Shift Direction

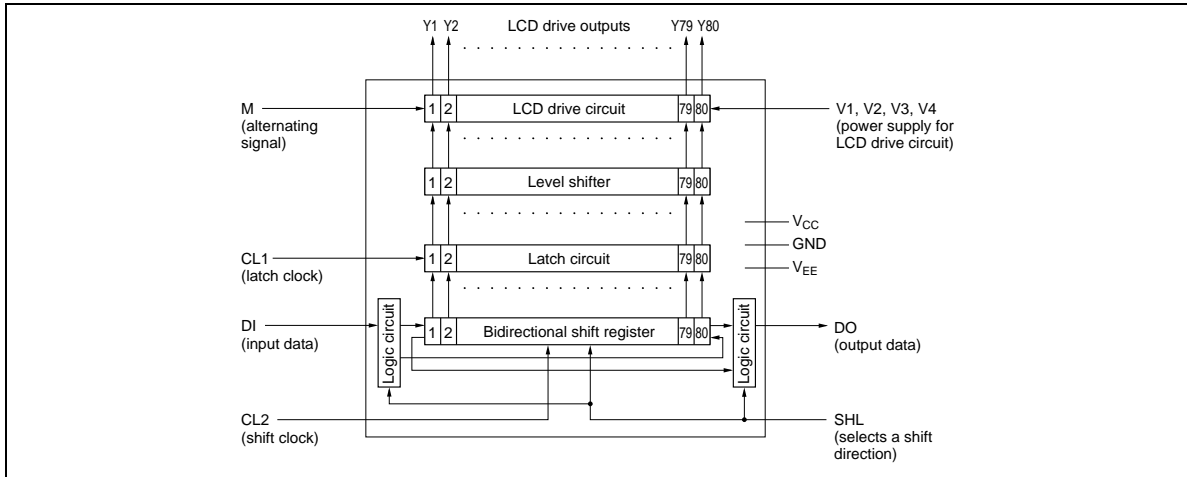

Figure 4 Block Diagram

Primary Operations

Shifting Data

The input data DI shifts at the fall of CL2 and the data delayed 80 bits by the shift register is output from the DO terminal. The output of DO changes synchronously with the rise of CL2. This operation is completely unaffected by the latch clock CL1.

Latching Data

The data of the shift register is latched at the negative edge of the latch clock CL1. Thus, the outputs Y1–Y80 change synchronously with the fall of CL1.

Switching Data Shift Direction

When the shift direction switching signal SHL is connected with GND, the data D80, immediately before the negative edge of CL1, is output from the output terminal Y1. When SHL is connected with V_{CC} , it is output from Y80.

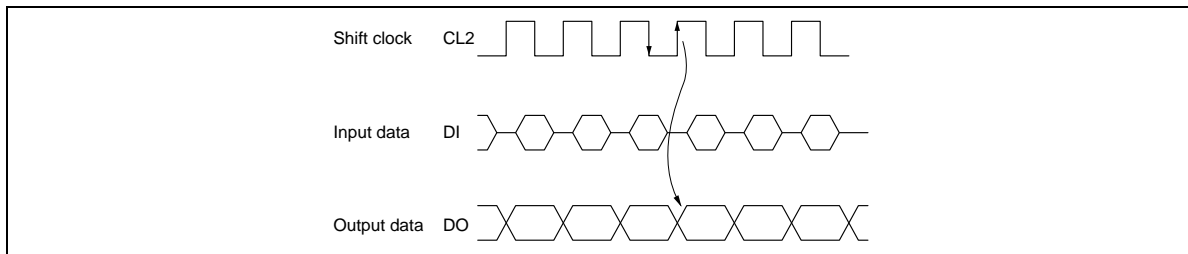

Figure 5 Timing of Receiving and Outputting Data

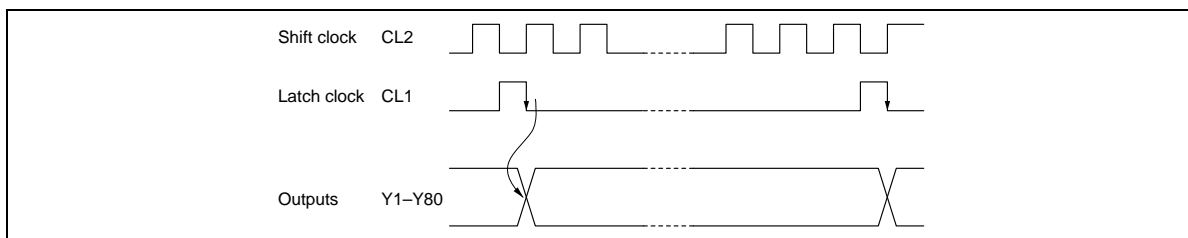

Figure 6 Timing of Latching Data

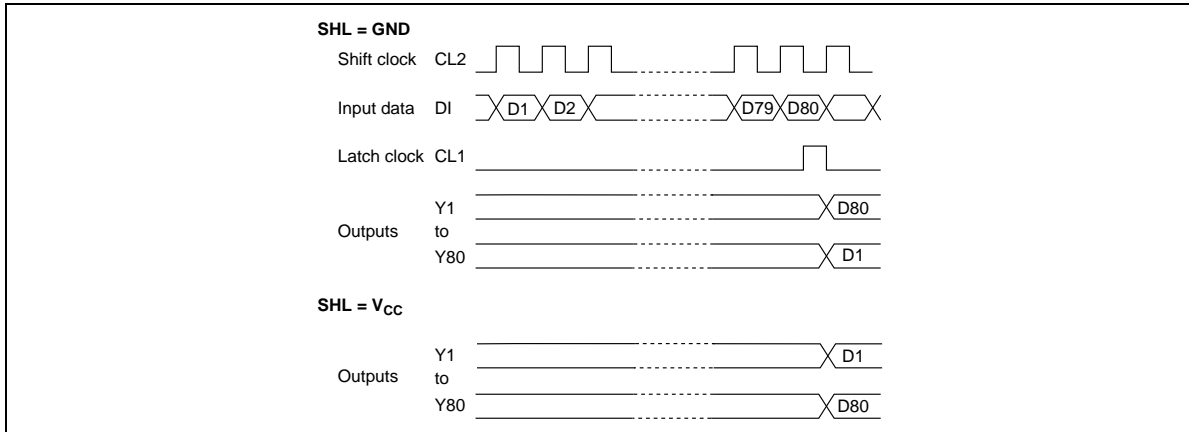

Figure 7 SHL and Waveforms of Data Shift

Absolute Maximum Ratings

Item		Symbol	Ratings	Unit	Note
Supply voltage	Logic circuits	V_{CC}	-0.3 to +7.0	V	1
	LCD drive circuits	$V_{CC}-V_{EE}$	-0.3 to +7.0	V	
Input voltage (1)		VT1	-0.3 to $V_{CC} + 0.3$	V	1
Input voltage (2)		VT2	$V_{CC} + 0.3$ to $V_{EE} - 0.3$	V	2
Operation temperature		T_{opr}	-20 to +75	°C	
Storage temperature		T_{stg}	-55 to +125	°C	

Notes: 1. A reference point is GND (= 0V)

2. Applies to V1–V4.

Note: If used beyond the absolute maximum ratings, LSIs may be permanently destroyed. It is best to use them at the electrical characteristics for normal operations. If they are not used at these conditions, it may affect the reliability of the device.

HD66100F

Electrical Characteristics

DC Characteristics ($V_{CC} = 5V \pm 10\%$, $V_{CC} - V_{EE} = 3.0$ to $6.0V$, $GND = 0V$, $T_a = -20$ to $+75^\circ C$)

Item	Symbol	Terminals	Min	Typ	Max	Unit	Test Condition	Note
Input high voltage	V_{IH}	CL1, CL2,	$0.8 \times V_{CC}$	—	V_{CC}	V		
Input low voltage	V_{IL}	M, DI, SHL	0	—	$0.2 \times V_{CC}$	V		
Output high voltage	V_{OH}	DO	$V_{CC} - 0.4$	—	—	V	$I_{OH} = -0.4$ mA	
Output low voltage	V_{OL}		—	—	0.4	V	$I_{OL} = +0.4$ mA	
On resistance V_i – V_j	R_{ON1}	Y1–Y80 V1–V4	—	—	11	k Ω	$I_{ON} = 0.1$ mA to one Y terminal	
	R_{ON2}		—	—	30	k Ω	$I_{ON} = 0.05$ mA to each Y terminal	
Input leakage current	I_{IL}	CL1, CL2, M, DI, SHL	–5.0	—	5.0	μA	$V_{in} = 0V$ to V_{CC}	
V_i leakage current	I_{VL}	V1–V4	–5.0	—	5.0	μA	Output Y1–Y80 open $V_{in} = V_{CC}$ to V_{EE}	
Current dissipation	I_{GND}		—	—	2.0	mA	$f_{CL2} = 1.0$ MHz	1
	I_{EE}		—	—	0.1	mA	$f_{CL1} = 2.5$ kHz	

Note: 1. Input/output currents are excluded; when an input is at the intermediate level in CMOS, excessive current flows from the power supply through the input circuit.
To avoid this, V_{IH} and V_{IL} must be fixed at V_{CC} and GND level respectively.

AC Characteristics ($V_{CC} = 5V \pm 10\%$, $V_{CC} - V_{EE} = 3.0$ to $6.0V$, $GND = 0V$, $T_a = -20$ to $+75^\circ C$)

Item	Symbol	Terminals	Min	Typ	Max	Unit	Note
Data shift frequency	f_{CL}	CL2	—	—	1	MHz	
Clock high level width	t_{CWH}	CL1, CL2	450	—	—	ns	
Clock low level width	t_{CWL}	CL2	450	—	—	ns	
Data set-up time	t_{SU}	DI	100	—	—	ns	
Clock set-up time (1)	t_{SL}	CL2	200	—	—	ns	1
Clock set-up time (2)	t_{LS}	CL1	200	—	—	ns	2
Output delay time	t_{pd}	DO	—	—	250	ns	3
Data hold time	t_{DH}	DI	100	—	—	ns	
Clock rise/fall time	f_{CT}	CL1, CL2	—	—	50	ns	

- Notes: 1. Set-up time from the fall of CL2 to that of CL1.
 2. Set-up time from the fall CL1 to that of CL2.
 3. Test terminal

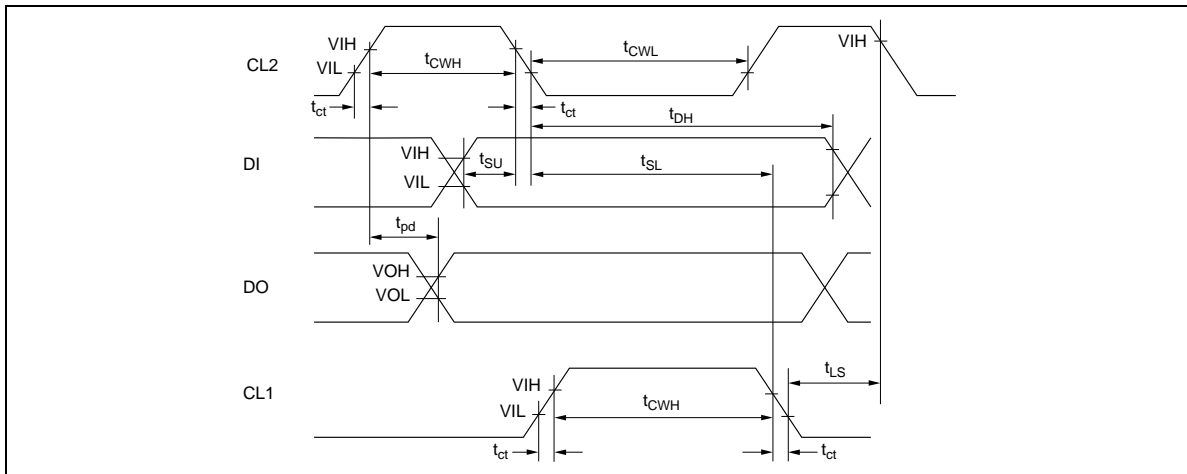
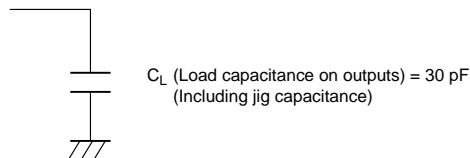

Figure 8 Timing Chart of HD66100F

HD66100F

Typical Applications

Connection with the LCD Controller HD44780

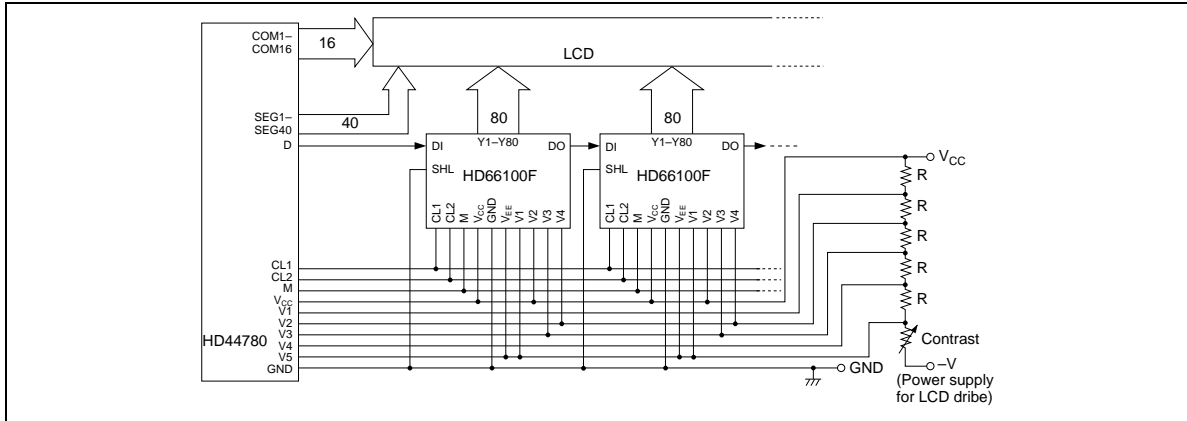

Figure 9 Example of Connection (1/16 Duty Cycle, 1/5 Bias)

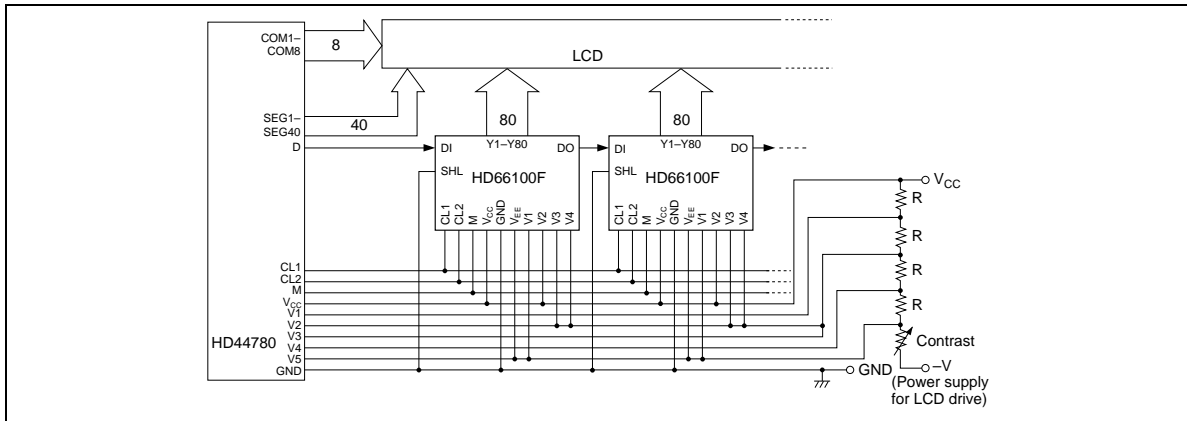

Figure 10 Example of Connection (1/8 Duty Cycle, 1/4 Bias)

Connection with LCD III (HD44790)

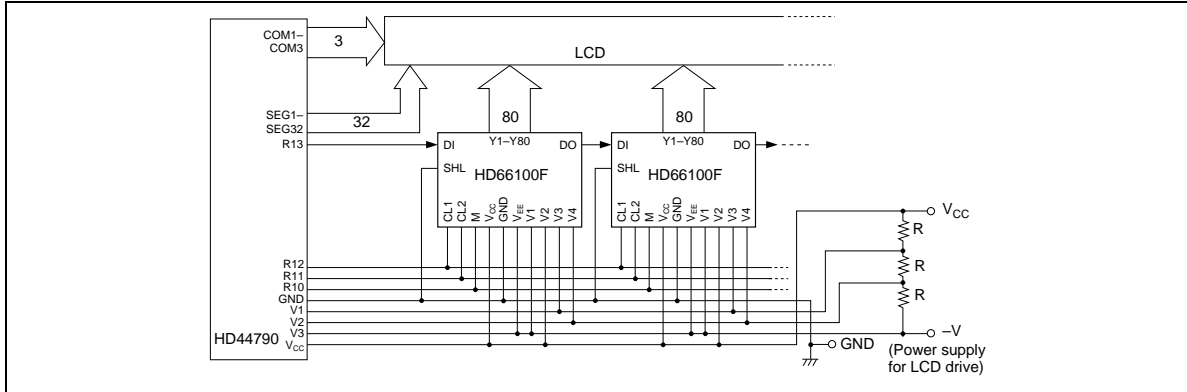

Figure 11 Example of Connection (1/3 Duty Cycle, 1/3 Bias)

Static Drive

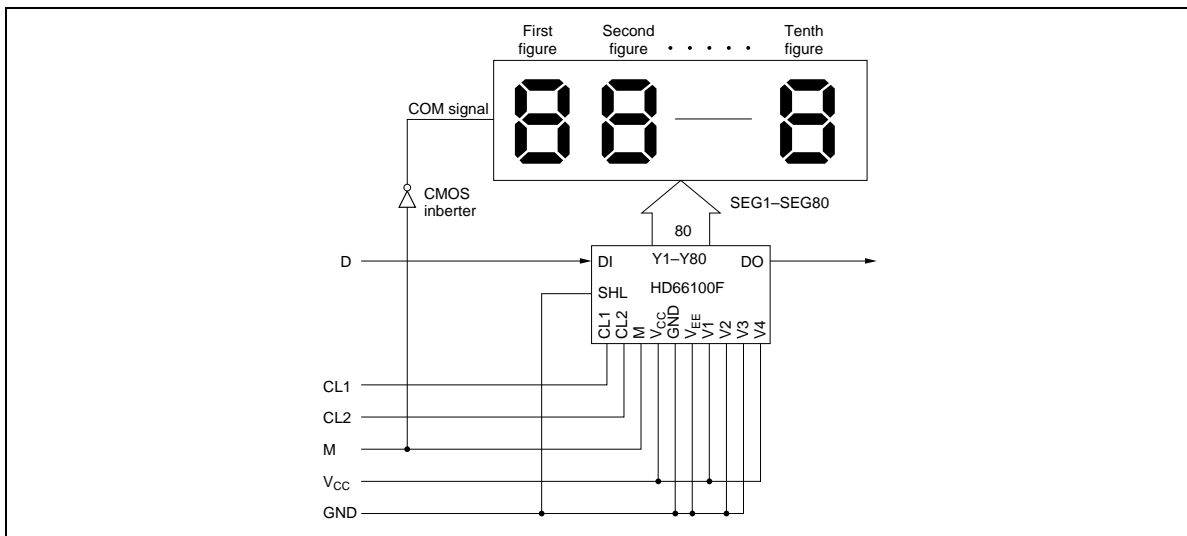

Figure 12 Example of Connection (80-Segment Display)

HD66100F

Timing Chart of Input Waveforms

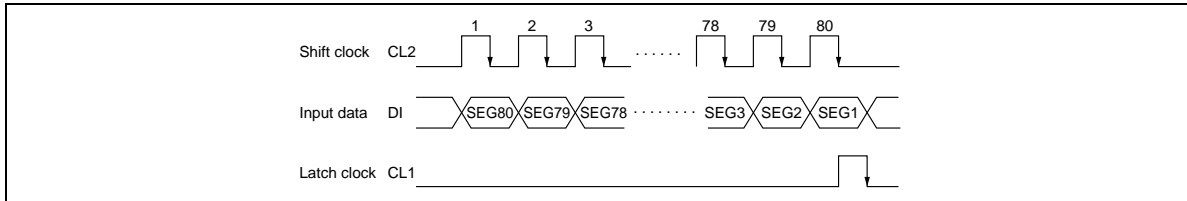

Figure 13 Timing Chart of Input Waveforms

- Notes:
1. Input square waves of 50% duty cycle (about 30–500 Hz) to M. The frequency depends on the specifications of LCD panels.
 2. The drive waveforms corresponding to the new displayed data are output at the fall of CL1. Therefore, when the alternating signal M and CL1 do not fall synchronously, DC elements are produced on the LCD drive waveforms. These DC elements may shorten the life span of the LCD, if the displayed data frequently changes (e.g. display of hours, minutes, and seconds of a clock). To avoid this, make CL1 fall synchronously with the one edge of M.
 3. In this example, the CMOS inverter is used as a COM signal driver in consideration of the large display area. (The load capacitance on COM is large because it is common to all the displayed segments.)

Usually, one of the HD66100F outputs can be used as a COM signal. The displayed data corresponding to the terminal should be 0 in that case.

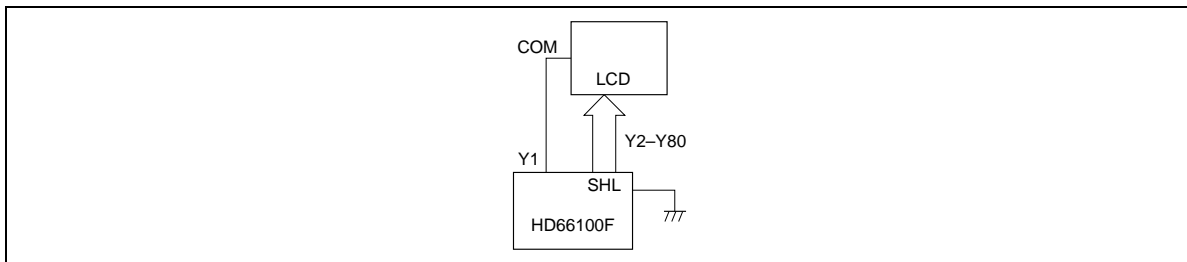

Figure 14 Example of Connection

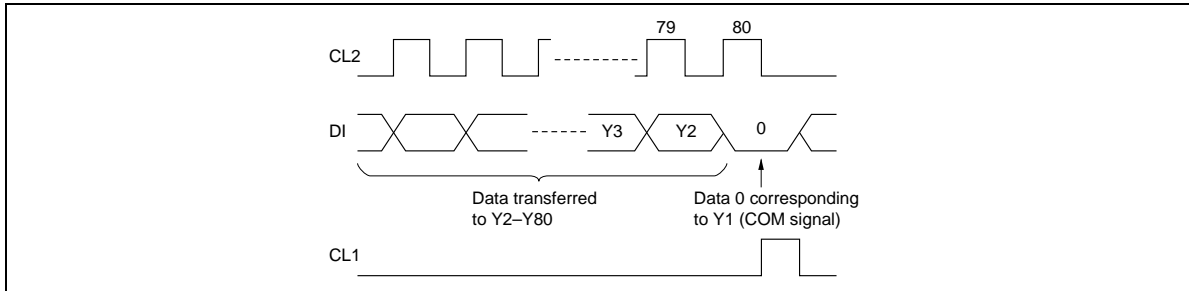

Figure 15 Timing Chart (when Y1 is Used as a COM Signal)