

# 3.96 mm Pitch Miniature Connectors for Internal Power Supplies (UL,C-UL and TÜV Listed)

## DF7 Series

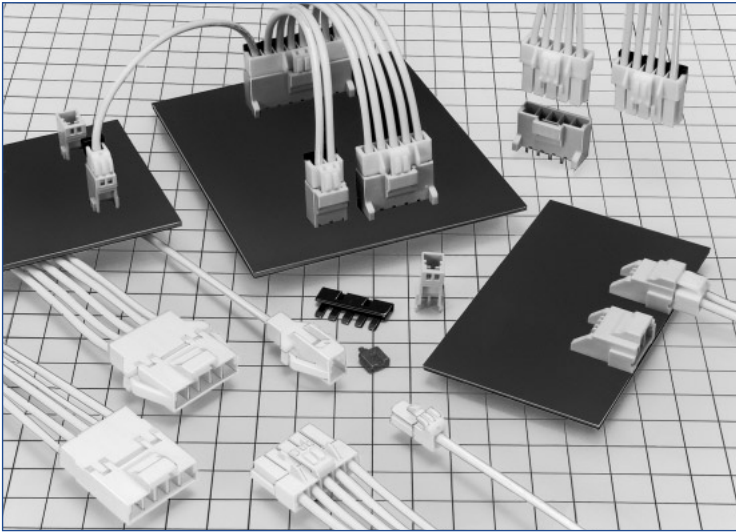

### Complete Locking Function

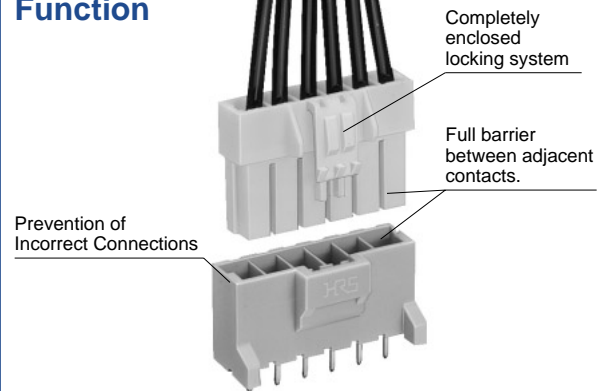

### Features

#### 1. Complete Locking Function

Reliable interior lock protects mated connectors from accidental disconnection.

#### 2. Increased Contact Retention of Crimped Contacts and Prevention of Incomplete Insertion

Separate contact retainer increases the contact retention, assures and visually confirms the complete contact insertion.

#### 3. Molded-in Contact Retention Tabs

Handling of terminated contacts during the assembly and termination is easier and avoids entangling of wires, since there are no protruding metal tabs.

#### 4. Incorrect Insertion Prevention

Connectors are polarized to assure correct mating with corresponding parts.

#### 5. Solder Crack Prevention

Glass reinforced resin is used in the pin header bodies to prevent solder cracks caused by the heat shrinkage.

#### 6. Prevention of Incorrect Board Placement

Built-in locating posts assure correct connector placement and orientation on the board.(2-12 pos.)

#### 7. Supports Sealing after Installation.

Sealing compound can be applied to the board installed connector for distance of 6 mm max. from the mounting surface (9 mm max. for single position).

#### 8. Cost Effective Tooling

The same crimping tools are used to terminate socket and pin contacts.

#### 9. Prevention of Short Circuits between Adjacent Contacts

Each contact is completely surrounded by the insulator housing, electrically isolating it from adjacent contacts.

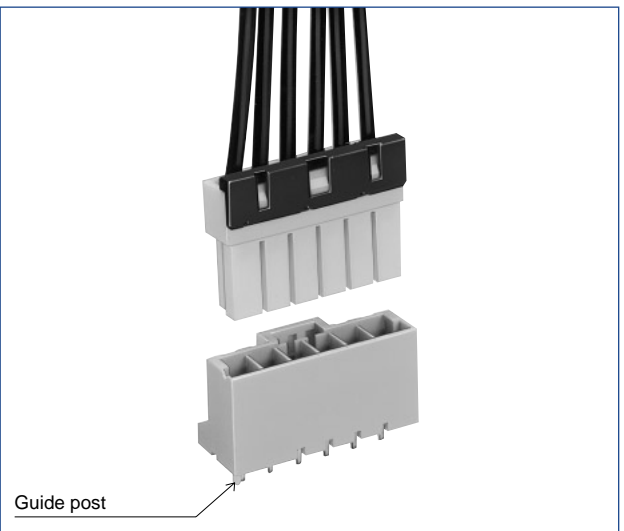

### Board Eyelet mounting

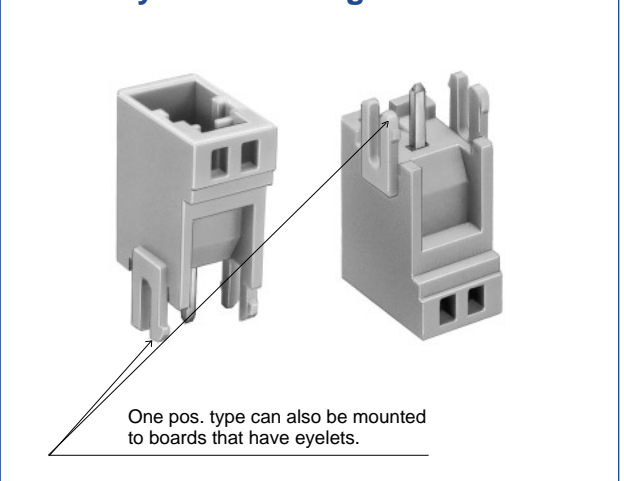

Continued.

## 10. 10 A maximum Current

Connector can carry current of 10 A per contact with #16 AWG conductor. Refer to page 3 for current ratings for multi-position connectors using other conductor sizes.

## 11. Color Variations





1 pos. is available in a standard 3 colors: natural, blue, and red.

## 12. Supports Eyelets

1 pos. can be mounted to boards which have eyelets attached.

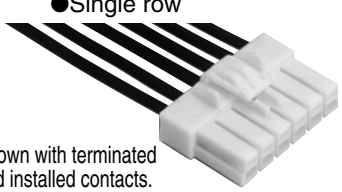
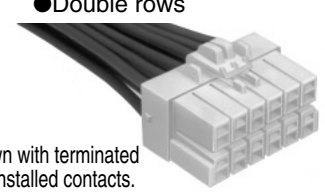
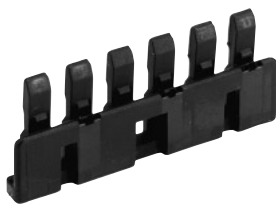
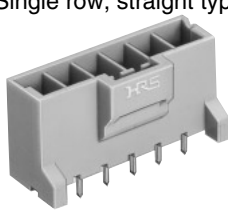
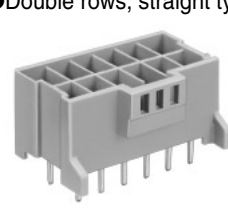
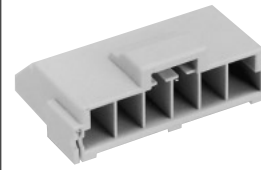
## Applications

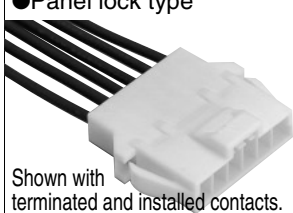
Office equipment, power supplies for industrial, medical and instrumentation applications, variety of consumer electronic and electrical applications.

Crimp Sockets		Retainer (optional, order separately)
<p>● Single row</p>  <p>Shown with terminated and installed contacts. Refer to page 8, 9 for details.</p>	<p>● Double rows</p>  <p>Shown with terminated and installed contacts. Refer to page 12 for details.</p>	
Header		 <p>Refer to page 10 for details.</p>
<p>● Single row, straight type</p>  <p>Refer to page 4 for details.</p>	<p>● Double rows, straight type</p>  <p>Refer to page 11 for details.</p>	
<p>● Single row, right angle type</p>  <p>Refer to page 5 for details.</p>	<p>● Double row, right angle type</p>  <p>Refer to page 11 for details.</p>	
In-line plug		
<p>● Panel lock type</p>  <p>Shown with terminated and installed contacts. Refer to page 6 for details.</p>		
 <p>Shown with terminated and installed contacts. Refer to page 7 for details.</p>		

## Ordering information

● Socket, Header

**DF7 - \* S - 3.96 C**

①      ②   ③      ④      ⑤

● Contacts

**DF7 - \*\* SCF**

①      ⑥      ⑦

① Series name: DF7, DF7A, DF7E	⑥ Applicable Conductor 1618: AWG 16 to AWG 18 2022: AWG 20 to AWG 22 2426: AWG 24 to AWG 26
② Number of contacts: 1 to 5	
③ Connector type S: Socket DS: Double-row socket P: Header DP: Double-row Header EP: In-line plug RS/P: Retainer	⑦ Packaging SCF: Socket contacts / Reel SC: Socket contacts / Bag PCF: Plug contacts / Reel PC: Plug contacts / Bag
④ Contact pitch: 3.96mm(7.92 mm)	
⑤ Type of housing: header C: Crimp housing DSA: Straight header DS: Right-angle header Blank: Retainer	

## ■Product Specifications

Ratings	Current rating	Row	No. of contacts	AWG16	AWG18	AWG20	AWG22	AWG24	AWG26			
		1	2~10	10A	7A	5A	4A	4A	3A	Operating temperature range	-35°C to 85°C (Note 1)	
		2	4	10A	9A	7A	6A	4A	3A	Operating humidity range	20% to 80%	
			6	9A	8A	6A	5A	4A	3A			
			8	9A	8A	6A	5A	4A	3A	Storage temperature range	-10°C to 60°C (Note 2)	
			10	8A	7A	5A	4A	4A	3A			
	12	8A	7A	5A	4A	4A	3A	Storage humidity range	40% to 70% (Note 2)			
	Voltage rating	Specification				AC630V				UL/C-UL/TÜV File No. and Recognition No		
		UL/C-UL				AC/DC 600V				UL	:E52653	
		TÜV				AC/DC 600V(7.92mm pitch)				C-UL	:E52653	
AC/DC 300V (3.96mm pitch)						TÜV	:R9750437					

Item	Specification	Condition
1. Contact resistance	Contact resistance(Initial value)	10 m ohms max. 20mV max., 1mA
2. Insulator resistance	1000 M ohms min.	500 V DC
3. Withstanding voltage	No flashover or Insulator breakdown	1500 V AC for 1 minute
4. Insertion-Extraction force (per contact)	0.3N min., 4.5N max.	Measured with a steel pin of 0.64 x 1.2 ± 0.002 mm
5. Durability (mating/unmating)	30 cycles	Contact resistance of 20 m ohms max.
6. Vibration	No momentary disconnections of 1 μs min.	Frequency 10 to 55 Hz, single amplitude of 0.75 mm, 3 axis, 2 hours
7. Shock	No electrical discontinuity of 1 μs. min.	Acceleration of 490 m/s <sup>2</sup> , 11 ms duration, sine half-wave waveform, 3 cycles in each of the 3 axis.
8. Humidity	Contact resistance 20 m ohms max.	Temperature 40°C ± 2°C, 90% to 95% RH, 96 hours
9. Temperature cycle	Contact resistance of 20 m ohms max.	(-55°C: 30 minutes → 5 to 35°C: 5 minutes → 85°C: 30 minutes → 5 to 35°C: 5 minutes) for 5 cycles
10. Resistance to soldering heat	No deformation of the insulator parts affecting performance	Flow solder temperature 250°C, 10 seconds Manual soldering: Soldering iron temperature 300°C, 3 seconds

Note 1: Includes temperature rise caused by the current flow.

Note 2: The term “storage” refers to products stored for long period of time prior to mounting and use. Operating Temperature Range and Humidity range covers non- conducting condition of installed connectors in storage, shipment or during transportation.

## ■Materials

Product	Part	Material	Finish	Remarks
Sockets	Insulator	Polyamide	Color: White	UL94V-0
Headers	Insulator	Polyamide (Glass reinforced)	Color: Beige (Single row) Color: Grey (Double row)	UL94V-0
	Contact	High conductivity copper alloy	Tin-lead plating (Note)	—
In-line plug	Insulator	Polyamide	Color: White	UL94V-0
Retainer	Insulator	Polyamide	Color: Black	UL94V-0
Crimp contacts	Contacts	High conductivity copper alloy	Tin plating (Note)	—

Note: Hirose Electric's plating incorporates anti-whisking compounds.

## ■ Straight header

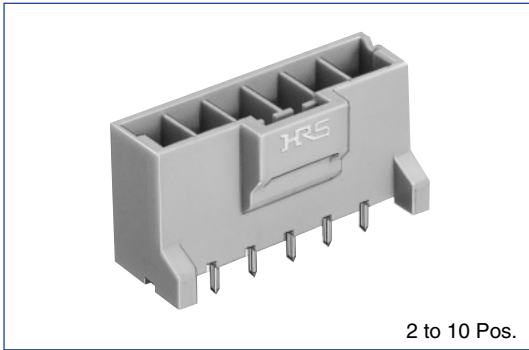
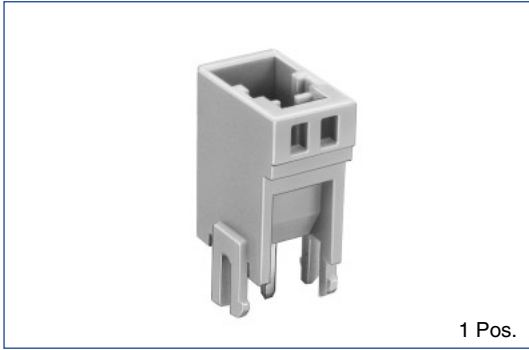

Part Number	CL No.	Number of contacts	A	B
DF7- 1P-3.96DSA	CL680-0133-1	1	———	———
DF7- 2P-3.96DSA	CL680-0036-5	2	10.40	3.96
DF7- 3P-3.96DSA	CL680-0037-8	3	14.36	7.92
DF7- 4P-3.96DSA	CL680-0038-0	4	18.32	11.88
DF7- 5P-3.96DSA	CL680-0039-3	5	22.28	15.84
DF7- 6P-3.96DSA	CL680-0040-2	6	26.24	19.80
DF7- 7P-3.96DSA	CL680-0041-5	7	30.20	23.76
DF7- 8P-3.96DSA	CL680-0042-8	8	34.16	27.72
DF7- 9P-3.96DSA	CL680-0043-0	9	38.12	31.68
DF7-10P-3.96DSA	CL680-0044-3	10	42.08	35.64
DF7- 2P-7.92DSA	CL680-0108-4	2	14.36	7.92
DF7- 3P-7.92DSA	CL680-0109-7	3	22.28	15.84
DF7- 4P-7.92DSA	CL680-0110-6	4	30.20	23.76
DF7- 5P-7.92DSA	CL680-0111-9	5	38.12	31.68

Note 1) Bag packaging (100 pieces/bag). Order by number of bags.

Note 2) The 2 pos. type does not have walls on both sides.

Note 3) DF7-2P-7.92DSA plug has #2 contact positions of DF7-3P-3.96DSA without contacts inserted and the number of pos. indication is 2.  
 (Mating receptacle: DF7#-3S-3-96C)  
 DF7-3P-7.92DSA plug has #2 and #4 contact positions of DF7-5P-3.96DSA without contacts inserted and the number of pos. indication is 3.  
 (Mating receptacle: DF7#-5S-3-96C)  
 DF7-4P-7.92DSA plug has #2, #4 and #6 contact of DF7-7P-3.96DSA without contacts inserted and the number of pos. indication is 4.  
 (Mating receptacle: DF7#-7S-3-96C)  
 DF7-5P-7.92DSA plug has #2, #4, #6 and #8 contact positions of DF7-9P-3.96DSA without contacts inserted and the number of pos. indication is 5.  
 (Mating receptacle: DF7#-9S-3-96C)

1 Pos.

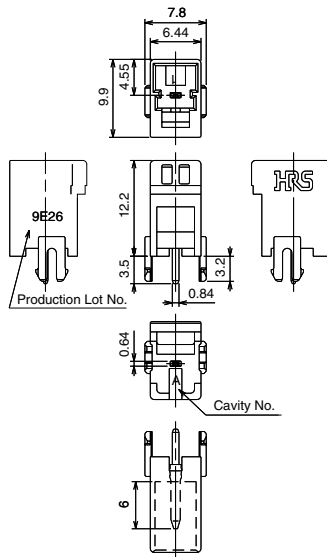

2 to 10 Pos.

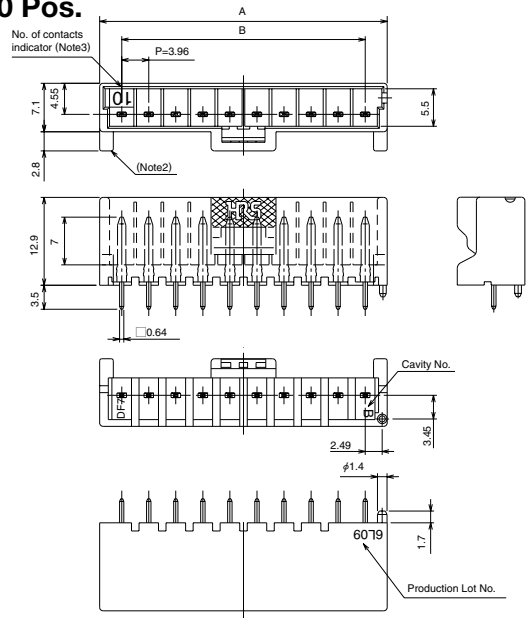

## ◆ PCB mounting pattern (Board thickness: 1.6 ± 0.1)

1 Pos.

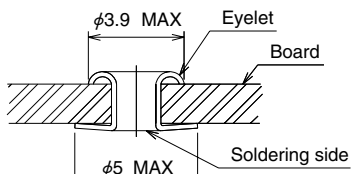

Note 5: One pos. type can also be mounted to boards that have installed eyelets.

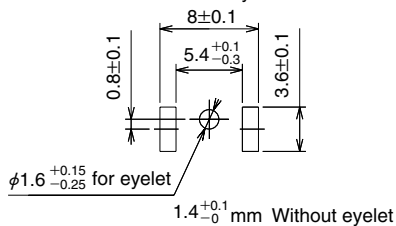

2 to 10 Pos.

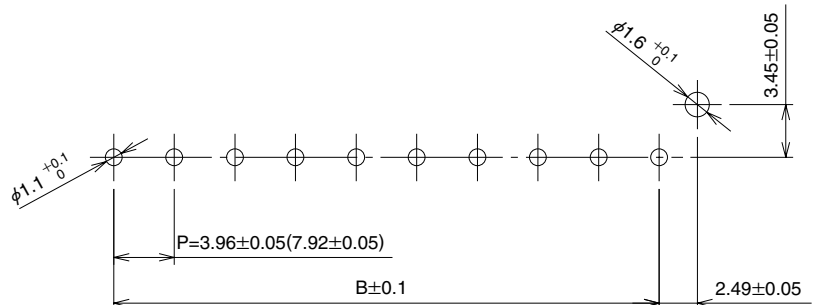

## Right angle header

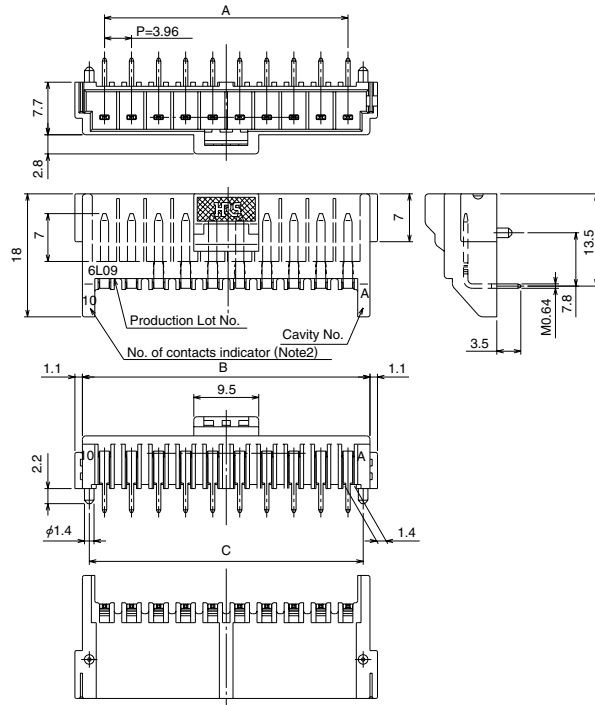
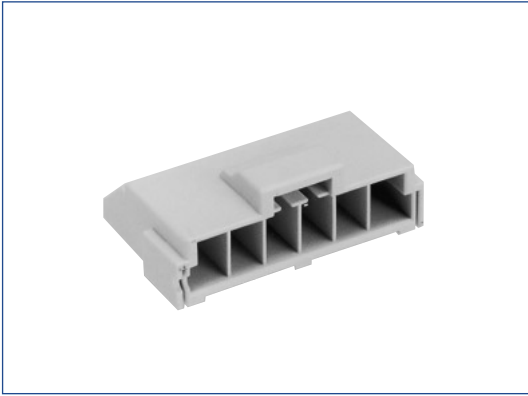

Part Number	CL No.	Number of contacts	A	B	C	Quantity per tray
DF7- 2P-3.96DS(24)	CL680-0081-0-24	2	3.96	10.40	8.40	114
DF7- 3P-3.96DS(24)	CL680-0082-2-24	3	7.92	14.36	12.36	84
DF7- 4P-3.96DS(24)	CL680-0083-5-24	4	11.88	18.32	16.32	66
DF7- 5P-3.96DS(24)	CL680-0084-8-24	5	15.84	22.28	20.28	60
DF7- 6P-3.96DS(24)	CL680-0085-0-24	6	19.80	26.24	24.24	48
DF7- 7P-3.96DS(24)	CL680-0086-3-24	7	23.76	30.20	28.20	42
DF7- 8P-3.96DS(24)	CL680-0087-6-24	8	27.72	34.16	32.16	36
DF7- 9P-3.96DS(24)	CL680-0088-9-24	9	31.68	38.12	36.12	36
DF7-10P-3.96DS(24)	CL680-0089-1-24	10	35.64	42.08	40.08	30
DF7- 2P-7.92DS(24)	CL680-0124-0-24	2	7.92	14.36	12.36	84
DF7- 3P-7.92DS(24)	CL680-0125-3-24	3	15.84	22.28	20.28	60
DF7- 4P-7.92DS(24)	CL680-0126-6-24	4	23.76	30.20	28.20	42
DF7- 5P-7.92DS(24)	CL680-0127-9-24	5	31.68	38.12	36.12	36

Note 1) Tray packaging. Order by number of quantity in the tray.

Note 2) DF7-2P-7.92DS plug has #2 contact positions of DF7-3P-3.96DS without contacts inserted and the number of pos. indication is 2.

(Mating receptacle: DF7#-3S-3-96C)

DF7-3P-7.92DS plug has #2 and #4 contact positions of DF7-5P-3.96DS without contacts inserted and the number of pos. indication is 3.

(Mating receptacle: DF7#-5S-3-96C)

DF7-4P-7.92DS plug has #2, #4 and #6 contact of DF7-7P-3.96DS without contacts inserted and the number of pos. indication is 4.

(Mating receptacle: DF7#-7S-3-96C)

DF7-5P-7.92DS plug has #2, #4, #6 and #8 contact positions of DF7-9P-3.96DS without contacts inserted and the number of pos. indication is 5.

(Mating receptacle: DF7#-9S-3-96C)

## PCB mounting pattern (Board thickness: $1.6 \pm 0.1$ )

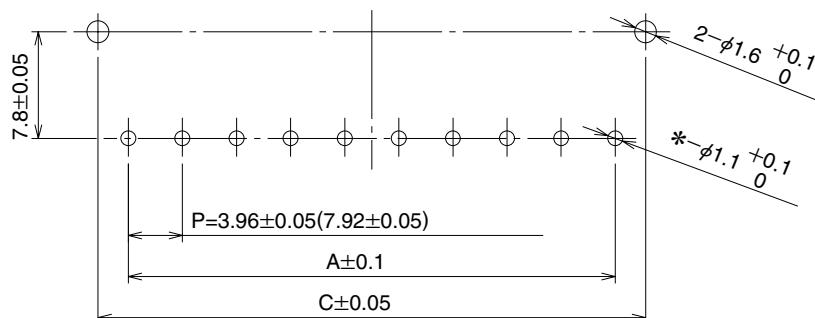

## ■ In-line plug (Panel lock type)

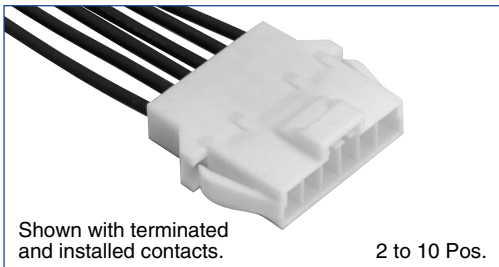
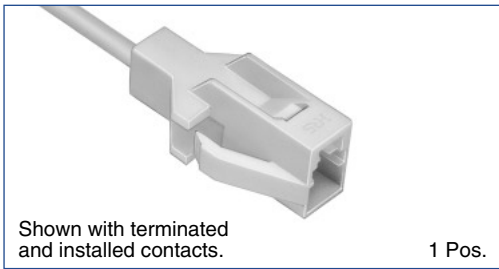

Part Number	CL No.	Number of contacts	A	B	C
DF7- 1EP-3.96C	CL680-0134-4	1	6.44	—	13.96
DF7- 2EP-3.96C	CL680-0018-3	2	10.40	3.96	17.40
DF7- 3EP-3.96C	CL680-0019-6	3	14.36	7.92	21.36
DF7- 4EP-3.96C	CL680-0020-5	4	18.32	11.88	25.32
DF7- 5EP-3.96C	CL680-0021-8	5	22.28	15.84	29.28
DF7- 6EP-3.96C	CL680-0022-0	6	26.24	19.80	33.24
DF7- 7EP-3.96C	CL680-0023-3	7	30.20	23.76	37.20
DF7- 8EP-3.96C	CL680-0024-6	8	34.16	27.72	41.16
DF7- 9EP-3.96C	CL680-0025-9	9	38.12	31.68	45.12
DF7-10EP-3.96C	CL680-0026-1	10	42.08	35.64	49.08

Note1: Bag packaging (100 pieces/bag). Order by number of bags.  
 Note2: Refer to page 10 for retainer.

### 1 Pos.

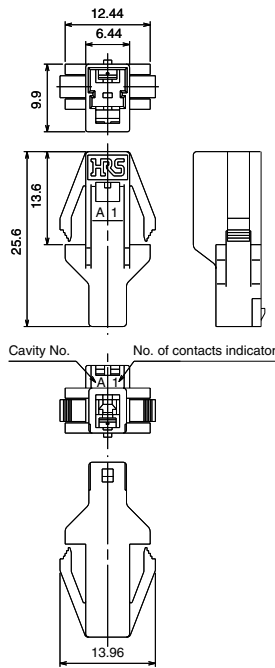

### 2 to 10 Pos.

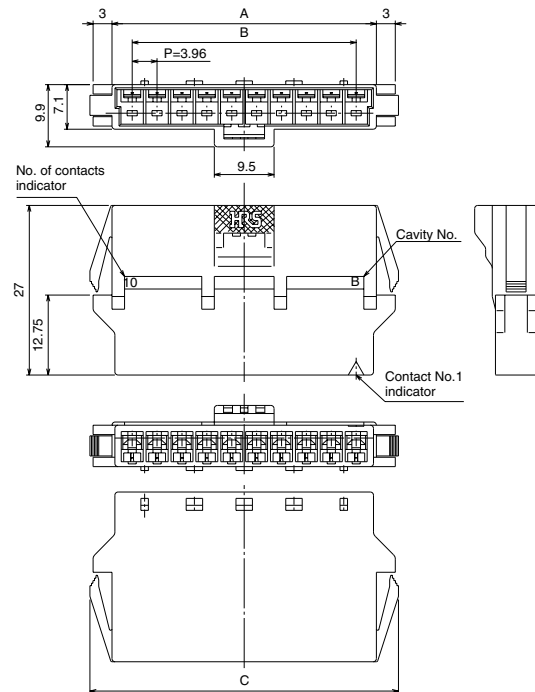

## ◆ Panel Cutout

### 1 Pos.

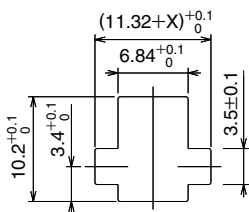

	X	Y
2.0	1.44	0.88
1.6	0.96	0.96
1.2	0.48	1.44
0.8	0	1.92

### 2 to 10 Pos.

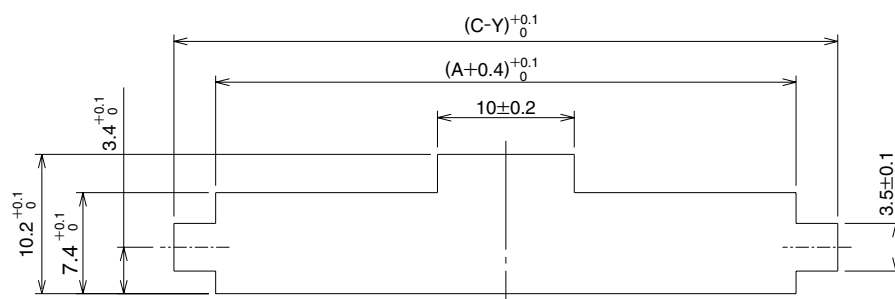

## ■ In-line Plug

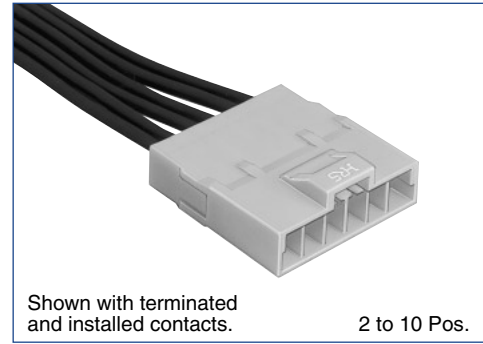
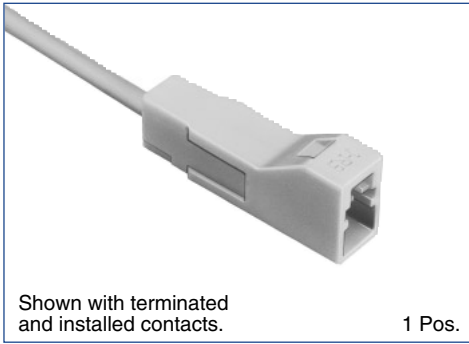

### 1 Pos.

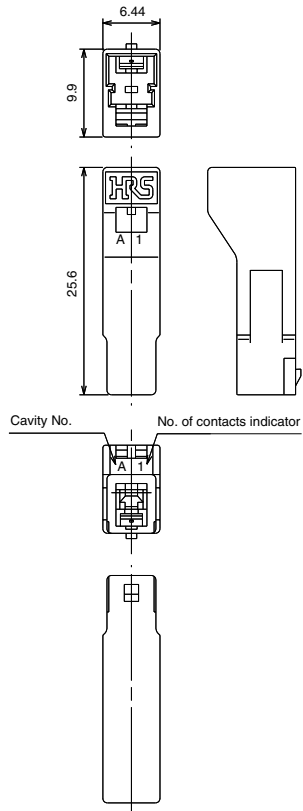

### 2 to 10 Pos.

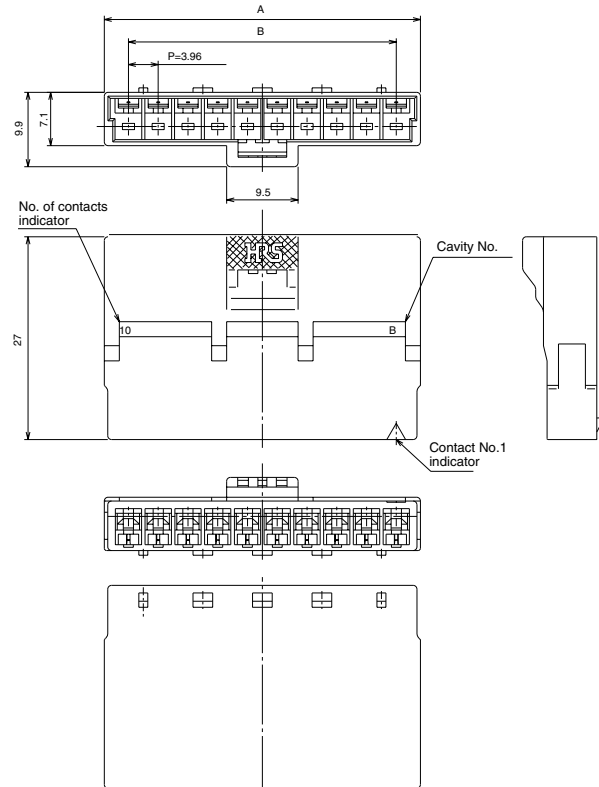

Part Number	CL No.	Number of contacts	A	B
DF7A- 1EP-3.96C	CL680-0135-7	1	6.44	—
DF7A- 2EP-3.96C	CL680-0072-9	2	10.40	3.96
DF7A- 3EP-3.96C	CL680-0073-1	3	14.36	7.92
DF7A- 4EP-3.96C	CL680-0074-4	4	18.32	11.88
DF7A- 5EP-3.96C	CL680-0075-7	5	22.28	15.84
DF7A- 6EP-3.96C	CL680-0076-0	6	26.24	19.80
DF7A- 7EP-3.96C	CL680-0077-2	7	30.20	23.76
DF7A- 8EP-3.96C	CL680-0078-5	8	34.16	27.72
DF7A- 9EP-3.96C	CL680-0079-8	9	38.12	31.68
DF7A-10EP-3.96C	CL680-0080-7	10	42.08	35.64

Note1: Bag packaging (100 pieces/bag). Order by number of bags.  
 Note2: Refer to page 10 for retainer.



## ■ Crimp Sockets

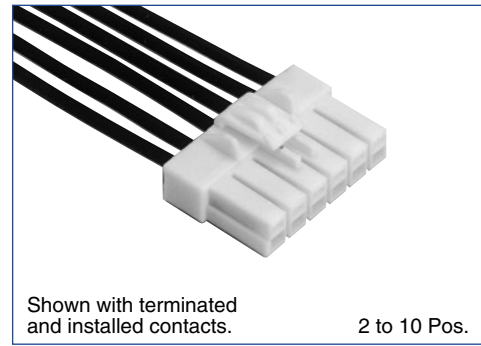
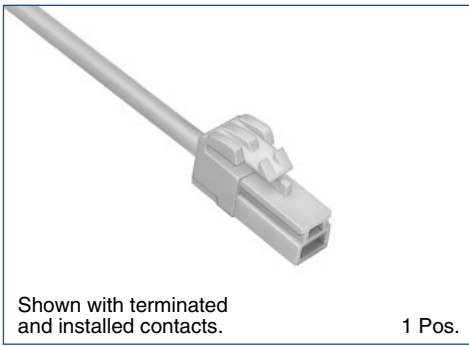

### 1 Pos.

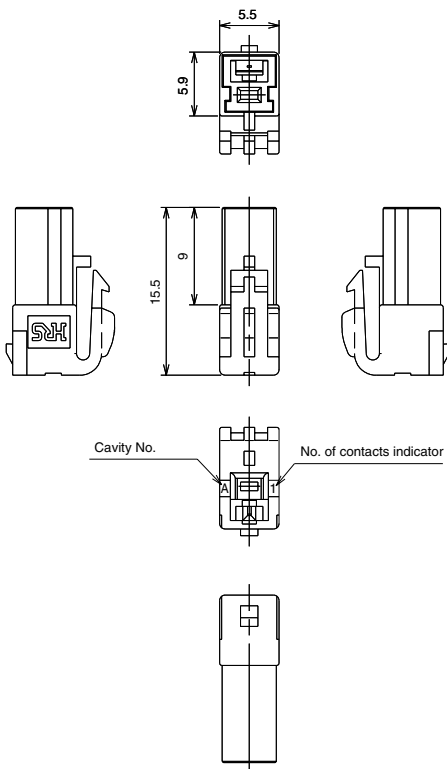

### 2 to 10 Pos.

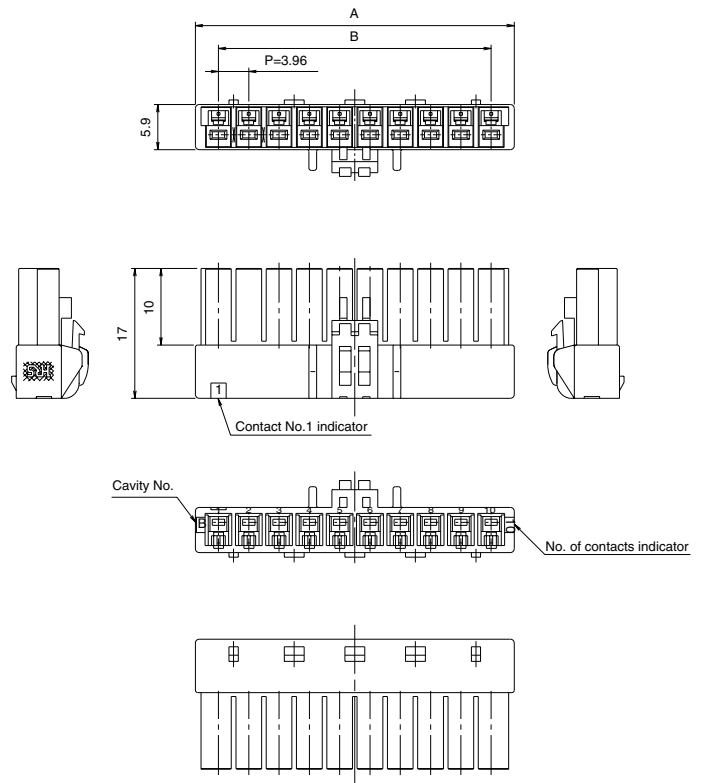

Part Number	CL No.	Number of contacts	A	B
DF7- 1S-3.96C	CL680-0132-9	1	5.50	—
DF7- 2S-3.96C	CL680-0009-2	2	10.00	3.96
DF7- 3S-3.96C	CL680-0010-1	3	13.96	7.92
DF7- 4S-3.96C	CL680-0011-4	4	17.92	11.88
DF7- 5S-3.96C	CL680-0012-7	5	21.88	15.84
DF7- 6S-3.96C	CL680-0013-0	6	25.84	19.80
DF7- 7S-3.96C	CL680-0014-2	7	29.80	23.76
DF7- 8S-3.96C	CL680-0015-5	8	33.76	27.72
DF7- 9S-3.96C	CL680-0016-8	9	37.72	31.68
DF7-10S-3.96C	CL680-0017-0	10	41.68	35.64

Note1: Bag packaging (100 pieces/bag). Order by number of bags.  
 Note2: Refer to page 10 for retainer.



## Low profile Crimp Sockets

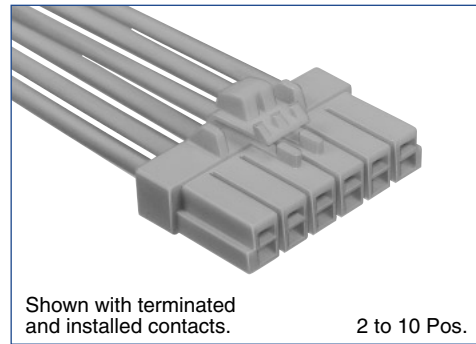
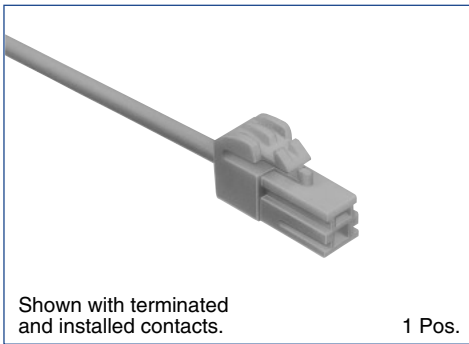

### 1 Pos.

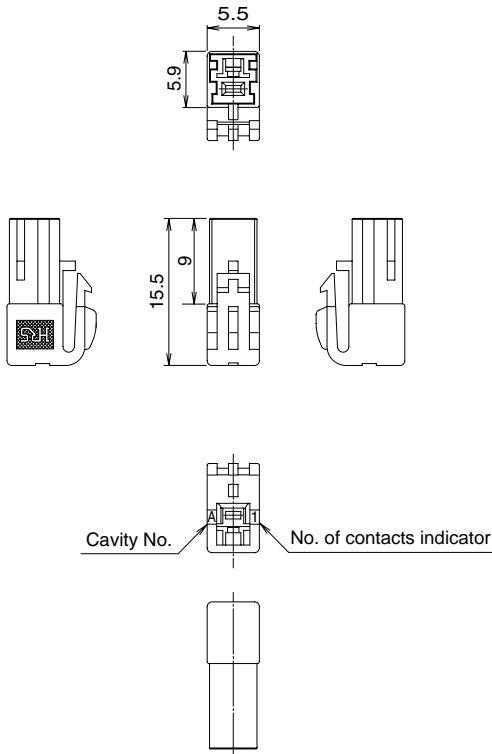

### 2 to 10 Pos.

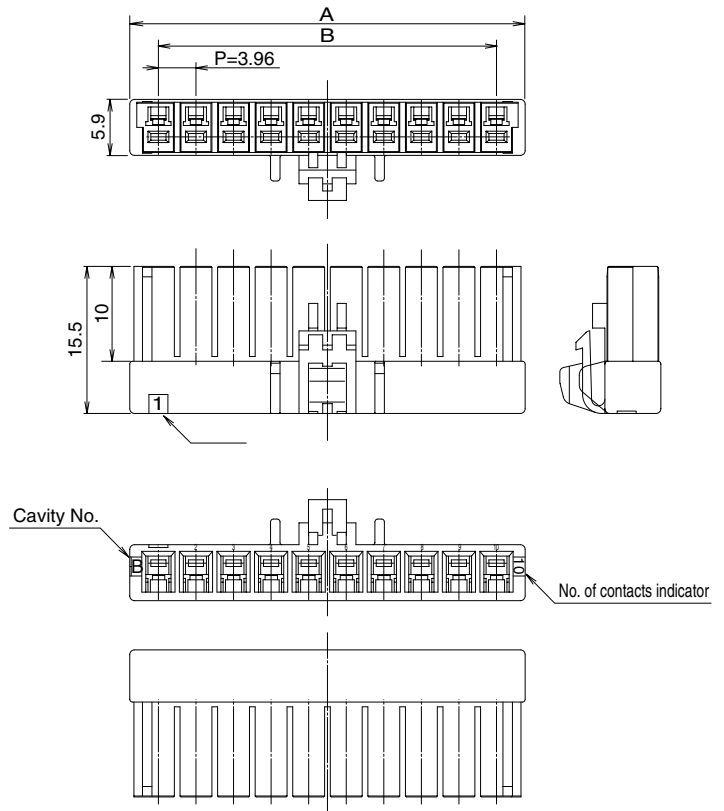

Part Number	CL No.	Number of contacts	A	B
DF7E- 1S-3.96C	CL680-0194-6	1	5.50	—
DF7E- 2S-3.96C	CL680-0195-9	2	10.00	3.96
DF7E- 3S-3.96C	CL680-0196-1	3	13.96	7.92
DF7E- 4S-3.96C	CL680-0197-4	4	17.92	11.88
DF7E- 5S-3.96C	CL680-0198-7	5	21.88	15.84
DF7E- 6S-3.96C	CL680-0199-0	6	25.84	19.80
DF7E- 7S-3.96C	CL680-0200-7	7	29.80	23.76
DF7E- 8S-3.96C	CL680-0201-0	8	33.76	27.72
DF7E- 9S-3.96C	CL680-0202-2	9	37.72	31.68
DF7E-10S-3.96C	CL680-0203-5	10	41.68	35.64

Note1: Bag packaging (100 pieces/bag). Order by number of bags.  
 Note2: Retainer is optional.  
 Note3: Refer to Page 14 for crimp contact.

## Retainer

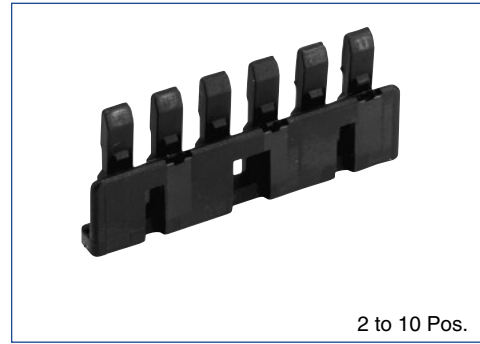
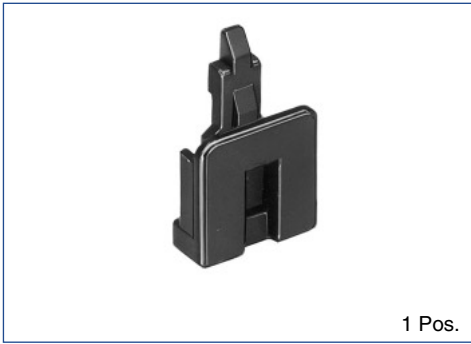

1 Pos.

2 to 10 Pos.

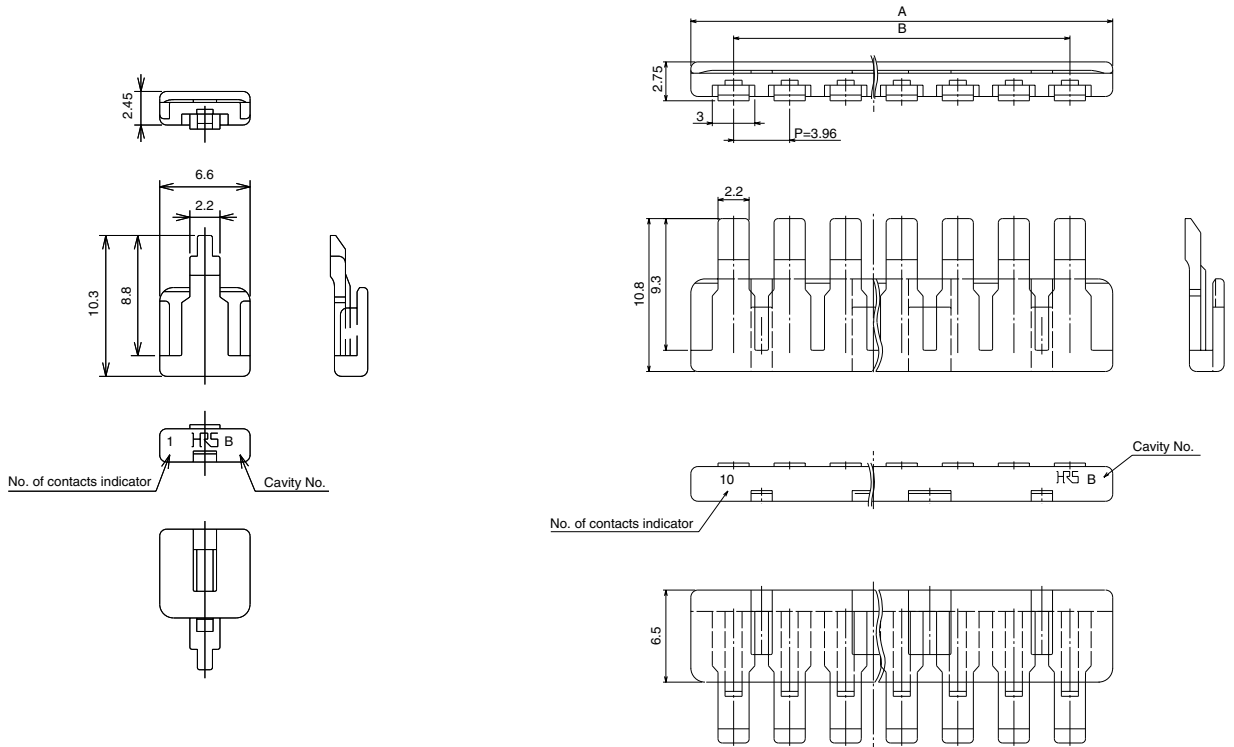

Part Number	CL No.	Number of contacts	A	B
DF7- 1RS/P-3.96	CL680-0136-0	1	—	—
DF7- 2RS/P-3.96	CL680-0027-4	2	10.00	3.96
DF7- 3RS/P-3.96	CL680-0028-7	3	13.96	7.92
DF7- 4RS/P-3.96	CL680-0029-0	4	17.92	11.88
DF7- 5RS/P-3.96	CL680-0030-9	5	21.88	15.84
DF7- 6RS/P-3.96	CL680-0031-1	6	25.84	19.80
DF7- 7RS/P-3.96	CL680-0032-4	7	29.80	23.76
DF7- 8RS/P-3.96	CL680-0033-7	8	33.76	27.72
DF7- 9RS/P-3.96	CL680-0034-0	9	37.72	31.68
DF7-10RS/P-3.96	CL680-0035-2	10	41.68	35.64

Note1: Bag packaging (100 pieces/bag). Order by number of bags.

Note2: Retainer is common to sockets, in-line plug.(Except low profile sockets)

## Double-row Straight Header

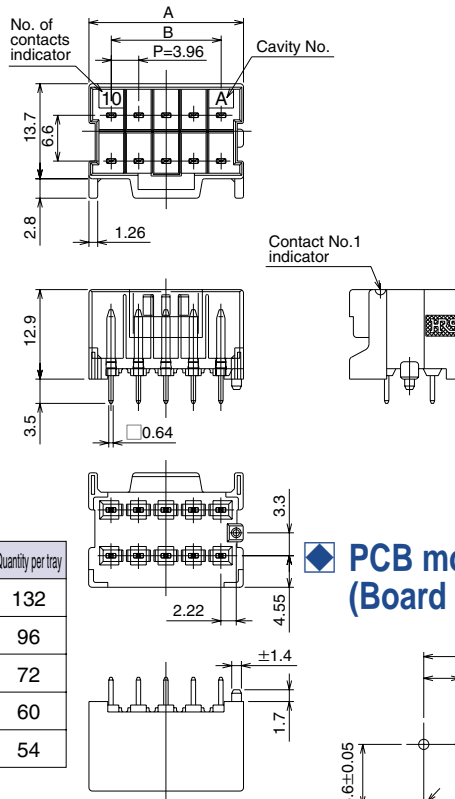
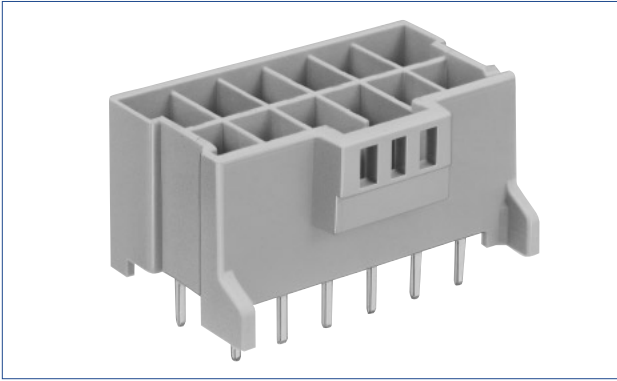

Part Number	CL No.	Number of contacts	A	B	Quantity per tray
DF7- 4DP-3.96DSA(24)	CL680-0145-0-24	4	10.40	3.96	132
DF7- 6DP-3.96DSA(24)	CL680-0146-3-24	6	14.36	7.92	96
DF7- 8DP-3.96DSA(24)	CL680-0147-6-24	8	18.32	11.88	72
DF7-10DP-3.96DSA(24)	CL680-0148-9-24	10	22.28	15.84	60
DF7-12DP-3.96DSA(24)	CL680-0149-1-24	12	26.24	19.80	54

Note: Tray packaging. Order by number of trays quantity.

### PCB mounting pattern (Board thickness: $1.6 \pm 0.1$ )

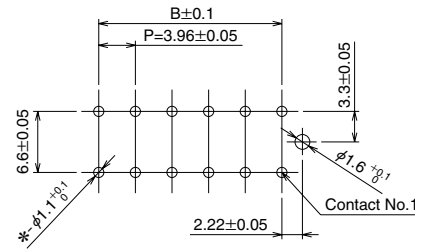

## Double-row Right angle Header

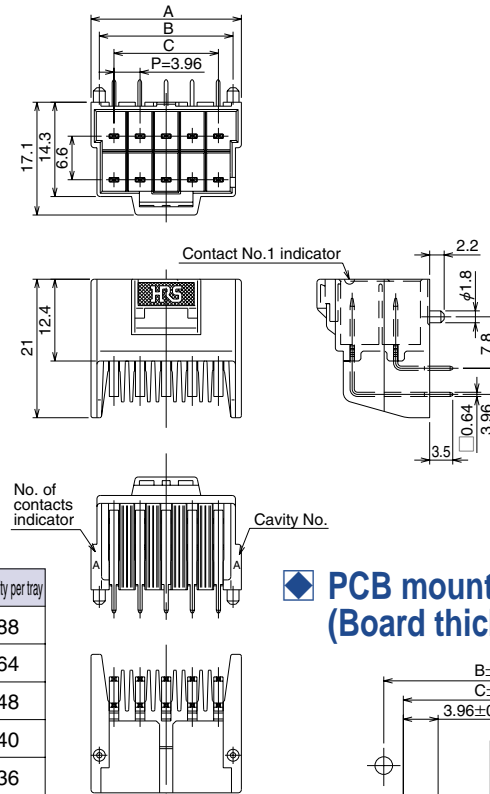
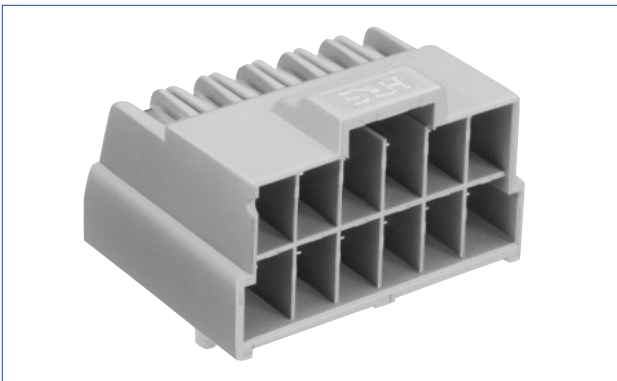

Part Number	CL No.	Number of contacts	A	B	C	Quantity per tray
DF7- 4DP-3.96DS(24)	CL680-0150-0-24	4	10.40	8.40	3.96	88
DF7- 6DP-3.96DS(24)	CL680-0151-3-24	6	14.36	12.36	7.92	64
DF7- 8DP-3.96DS(24)	CL680-0152-6-24	8	18.32	16.32	11.88	48
DF7-10DP-3.96DS(24)	CL680-0153-9-24	10	22.28	20.28	15.84	40
DF7-12DP-3.96DS(24)	CL680-0154-1-24	12	26.24	24.24	19.80	36

Note: Tray packaging. Order by number of trays quantity.

### PCB mounting pattern (Board thickness: $1.6 \pm 0.1$ )

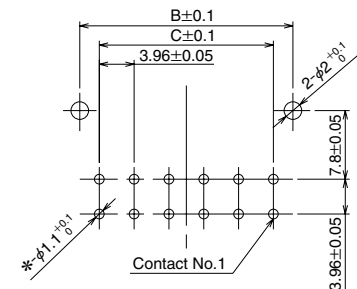

## ■ Double-row Socket

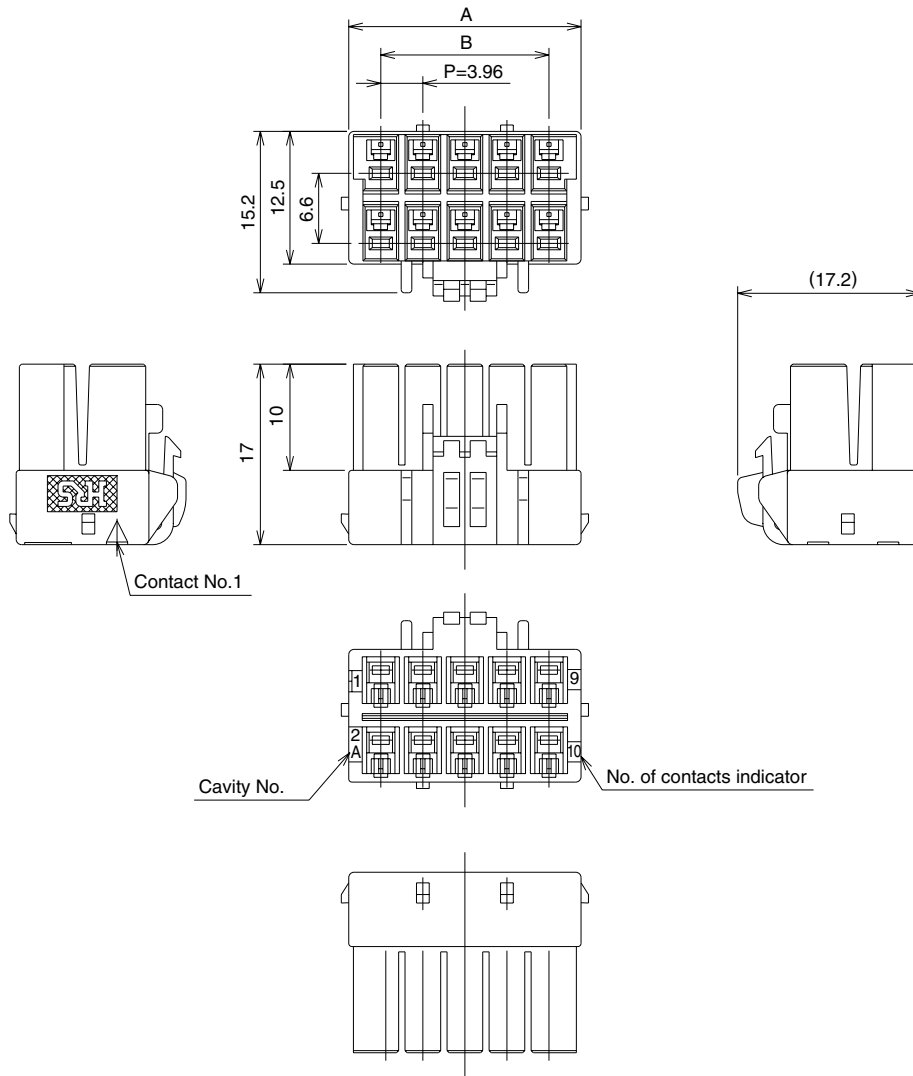
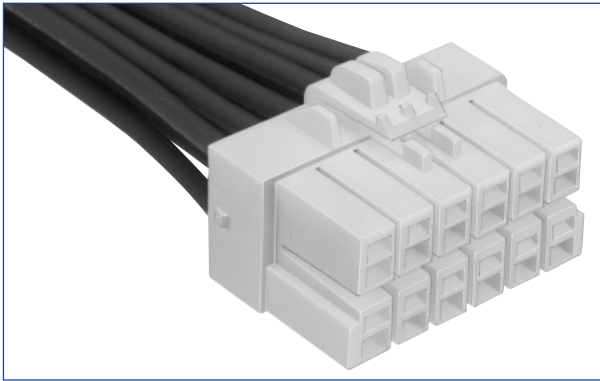

Part Number	CL No.	Number of contacts	A	B
DF7A-4DS-3.96C	CL680-0160-4	4	10.00	3.96
DF7A-6DS-3.96C	CL680-0161-7	6	13.96	7.92
DF7A-8DS-3.96C	CL680-0162-0	8	17.92	11.88
DF7A-10DS-3.96C	CL680-0163-2	10	21.88	15.84
DF7A-12DS-3.96C	CL680-0164-5	12	25.84	19.80

Note: Bag packaging (100 pieces/bag). Order by number of bags.

## ■ Crimp Contact

### ● Female Contact

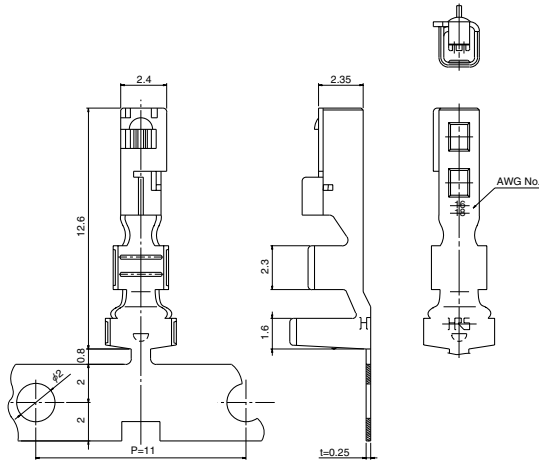

### ● Male Contact

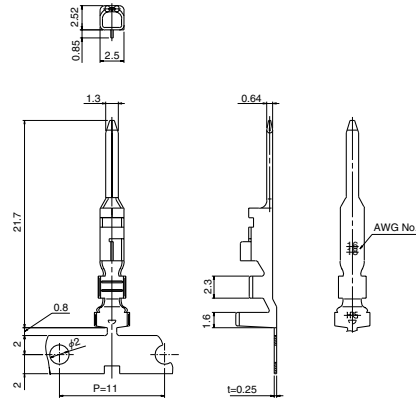

Part Number	CL No.	Packaging	Quantity	Finish
DF7-1618SCF	CL680-0001-0	Reel	3,000	Tin plating
DF7-1618SC	CL680-0002-3	Bag	100	
DF7-2022SCF	CL680-0003-6	Reel	3,000	
DF7-2022SC	CL680-0004-9	Bag	100	
DF7-2426SCF	CL680-0179-2	Reel	3,000	
DF7-2426SC	CL680-0180-1	Bag	100	
DF7-1618PCF	CL680-0005-1	Reel	3,000	
DF7-1618PC	CL680-0006-4	Bag	100	
DF7-2022PCF	CL680-0007-7	Reel	3,000	
DF7-2022PC	CL680-0008-0	Bag	100	
DF7-2426PCF	CL680-0181-4	Reel	3,000	
DF7-2426PC	CL680-0182-7	Bag	100	

## ● Applicable cable (Tin plated annealed copper wire)

Wire size(Stranded wire conductor)	UL style	Jacket diameter
AWG#16(26/0.254mm)	UL1007	2.1 to 2.5mm
AWG#18(34/0.18mm)		
AWG#20(21/0.18mm)		1.6 to 1.9mm
AWG#22(17/0.16mm)		
AWG#24(11/0.16mm)		1.3 to 1.45mm
AWG#26(7/0.16mm)		
AWG#16(26/0.254mm)	UL1015	2.9 to 3.2mm
AWG#18(34/0.18mm)		
AWG#20(21/0.18mm)		2.4 to 2.7mm
AWG#22(17/0.16mm)		

Note 1: When using other than the recommended wire, contact your nearest Hirose representative.

Note 2: Strip length: 3.0 to 3.8mm.

## ■ Tools

Type	Part Number	CL No.	Applicable Contacts	
Automatic	Press unit	CM-105	CL901-0005-4	
	Applicator	AP105-DF7-1618	CL901-4554-4	DF7-1618SCF/DF7-1618PCF
		AP105-DF7-2022	CL901-4553-1	DF7-2022SCF/DF7-2022PCF
		AP105-DF7-2426	CL901-4587-3	DF7-2426SCF/DF7-2426PCF
Manual	Crimp tools	HT104/DF7-1618	CL550-0268-0	DF7-1618SC/DF7-1618PC
		HT104/DF7-2022	CL550-0269-3	DF7-2022SC/DF7-2022PC
		HT104/DF7-2426	CL550-0293-8	DF7-2426SC/DF7-2426PC

## ■ Crimp Contact

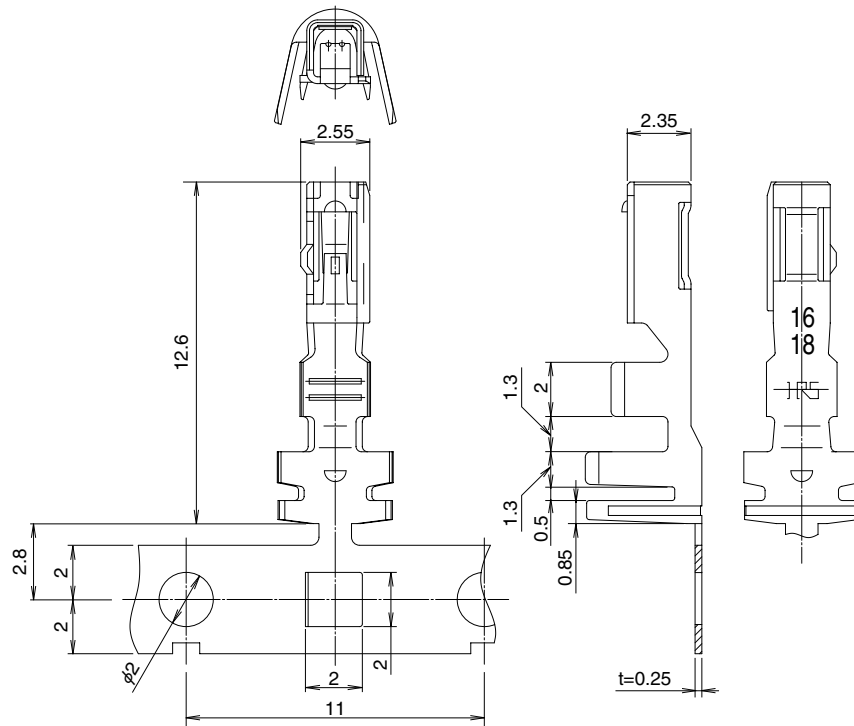

Part Number	CL No.	Packaging	Quantity	Finish
DF7E-1618SCF	CL680-0204-8	Reel	3,000	Tin plating
DF7E-1618SC	CL680-0205-0	Bag	100	
DF7E-2022SCF	CL680-0206-3	Reel	3,000	
DF7E-2022SC	CL680-0207-6	Bag	100	

### ● Applicable cable (Tin plated annealed copper wire)

Wire size (Stranded wire conductor)	UL style	Jacket diameter
AWG#16 (26/0.254mm)	UL1007	2.1mm to 2.5mm
AWG#18 (34/0.18mm)		
AWG#20 (21/0.18mm)		1.6mm to 1.9mm
AWG#22 (17/0.16mm)		

Note1: When using other than the recommended wire, contact your nearest Hirose representative.

Note2: Strip length: 2.7 to 3.5mm.

## ■ Tools

Type	Part Number	CL No.	Applicable contacts
Automatic	Press unit	CM-105	—
	Applicator	AP105-DF7E-1618	DF7E-1618SCF
		AP105-DF7E-2022	DF7E-2022SCF
Manual	Crimp tools	HT104/DF7E-1618	DF7E-1618SC
		HT104/DF7E-2022	DF7E-2022SC

## ◆ Mating Dimensions

### ● Socket to Straight Header Connection

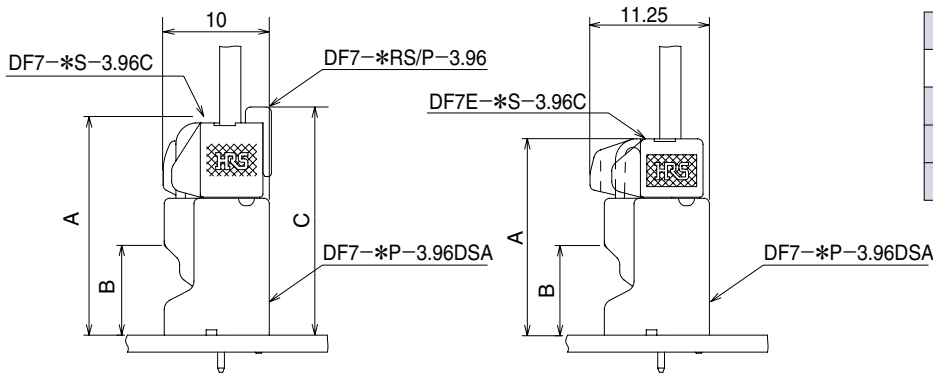

	DF7-*S-3.96C		DF7E-*S-3.96C
	1 pos.	2 to 12 pos.	2 to 12 pos.
A	18.5	20.0	18.5
B	9.0	8.5	9.0
C	20.3	21.5	—

Note: DF7-1P-3.96DSA can be mounted to boards which have eyelets attached.

### ● Socket to Straight Header Connection (Double-row)

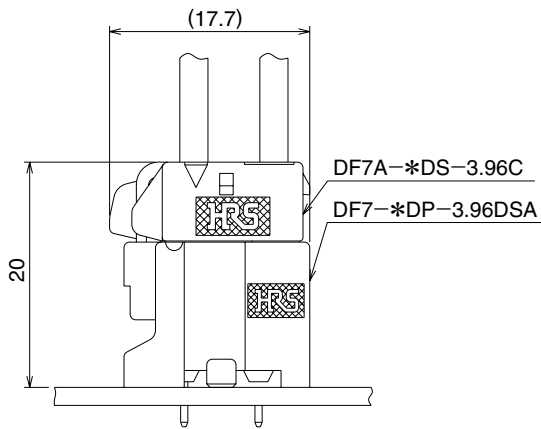

### ● Socket to Right angle Header Connection (Double-row)

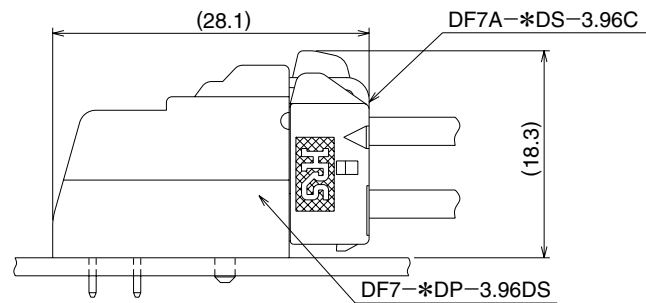

### ● Socket to Right angle Header Connection

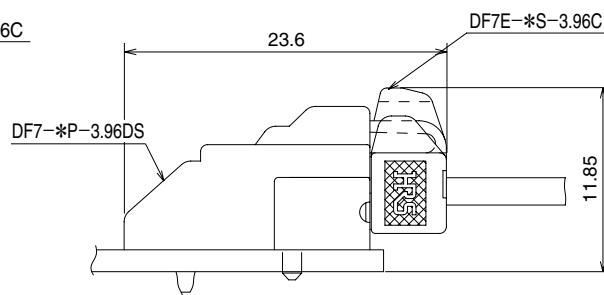
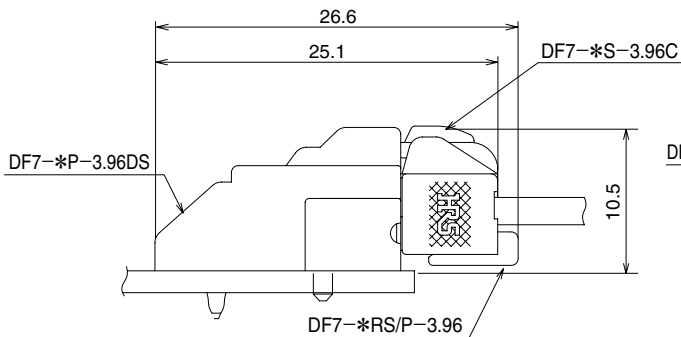

### ● Socket to In-line plug (Panel mount type) Connection

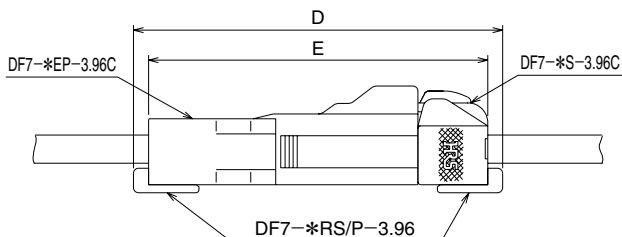

	1 pos.	2 to 10 pos.
D	35.1	37.0
E	32.1	34.0

### ● Socket to In-line plug Connection

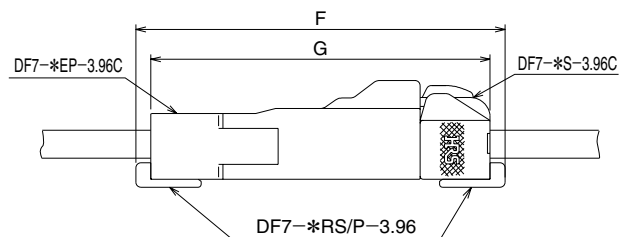

	1 pos.	2 to 10 pos.
F	35.1	37.0
G	32.1	34.0



## ◆ Contact Extraction Procedure

■ Contact extraction tool: Flat-bladed screwdriver, 1.4 mm blade width

■ Use with crimp Contacts: DF7-1618SC(F), DF7-2022SC(F),  
DF7-1618PC(F), DF7-2022PC(F)

### ■ Work Method

#### Housing Cross-Section

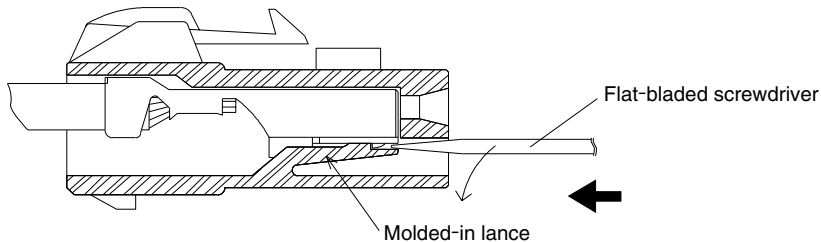

1. Refer to the drawing No. 1. Insert correct size screwdriver in the insulator against the molded-in lance. Deflect the lance as shown.

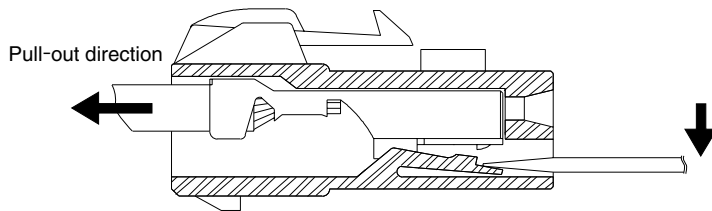

2. Assure that the lance is deflected to release the contact and pull-out wire with the terminated contact.

## ◆ General Use Precautions

- Make sure that the lock is fully depressed before un-mating the connectors.
- Use correct size of the wires. Do NOT forcefully twist or deform wires, as this may affect the crimped contact connection.
- When the potting process is to be performed, please take into consideration the surface tension of the resin when filling.



## HIROSE ELECTRIC CO.,LTD.

5-23,OSAKI 5-CHOME,SHINAGAWA-KU,TOKYO 141-8587,JAPAN  
PHONE: 81-3-3491-9741, FAX: 81-3-3493-2933  
<http://www.hirose.com>  
<http://www.hirose-connectors.com>