

CMOS Current Mode PWM Controller

Features

- Low Supply Current With CMOS Technology: 3.8mA Max
- Internal Reference: 5.1V
- Fast Rise/Fall Times ($C_L = 1000\text{pF}$): 50nsec
- Dual Push-Pull Outputs
- Direct-Power MOSFET Drive
- High Totem-Pole Output Drive: 300mA
- Differential Current-Sense Amplifier
- Programmable Current Limit
- Soft-Start Operation
- Double-Pulse Suppression
- Undervoltage Lockout
- Wide Supply Voltage Operation: 8V to 16V
- High Frequency Operation: 200kHz
- Available with Low OFF State Outputs
- Low Power, Pin-Compatible Replacement for UC3846

Applications

- Switching Power Supplies
- DC/DC Converters
- Motor Control

Device Selection Table

Part Number	Package	Temp. Range
TC170COE	16-Pin SOIC (Wide)	0°C to +70°C
TC170CPE	16-Pin PDIP (Narrow)	0°C to +70°C

General Description

The TC170 offers maximum supply current of 3.8mA. Bipolar current-mode control integrated circuits require five times more operating current.

The dual totem-pole CMOS outputs drive power MOSFETs or bipolar transistors. The 50nsec typical output rise and fall times (1000pF capacitive loads) minimize MOSFET power dissipation. Output peak current is 300mA.

The TC170 contains a full array of system-protection circuits (see Features Section).

Current-mode control lets users parallel power supply modules. Two or more TC170 controllers can be slaved together for parallel operation. Circuits can operate from a master TC170 internal oscillator or an external system oscillator.

The TC170 operates from an 8V to 16V power supply. An internal 2%, 5.1V reference minimizes external component count. The TC170 is pin compatible with the Unitrode UC1846/UC2846/UC3846 bipolar controller.

Other advantages inherent in current-mode control include superior line and load regulation and automatic symmetry correction in push-pull converters.

Package Type

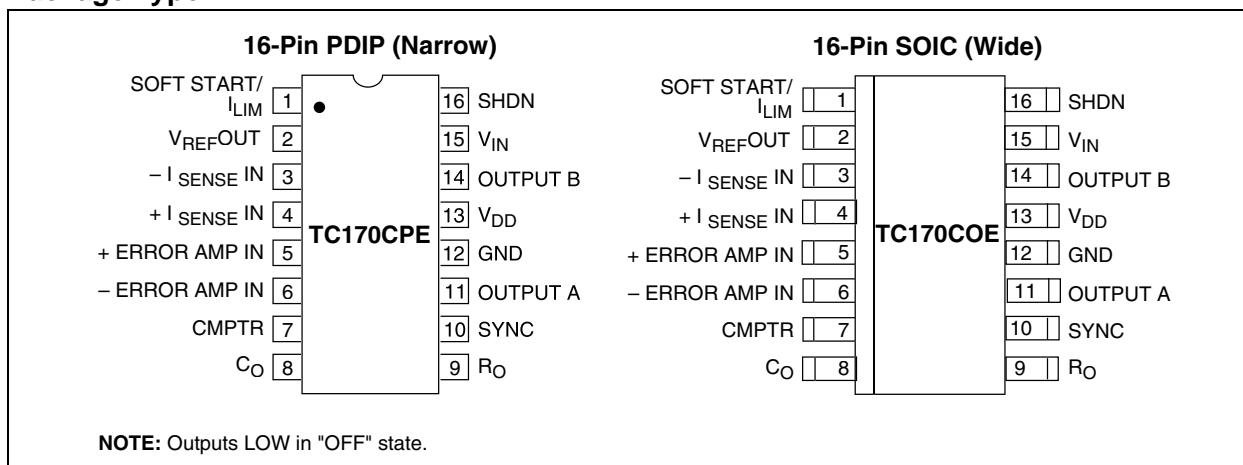

TC170

Functional Block Diagram

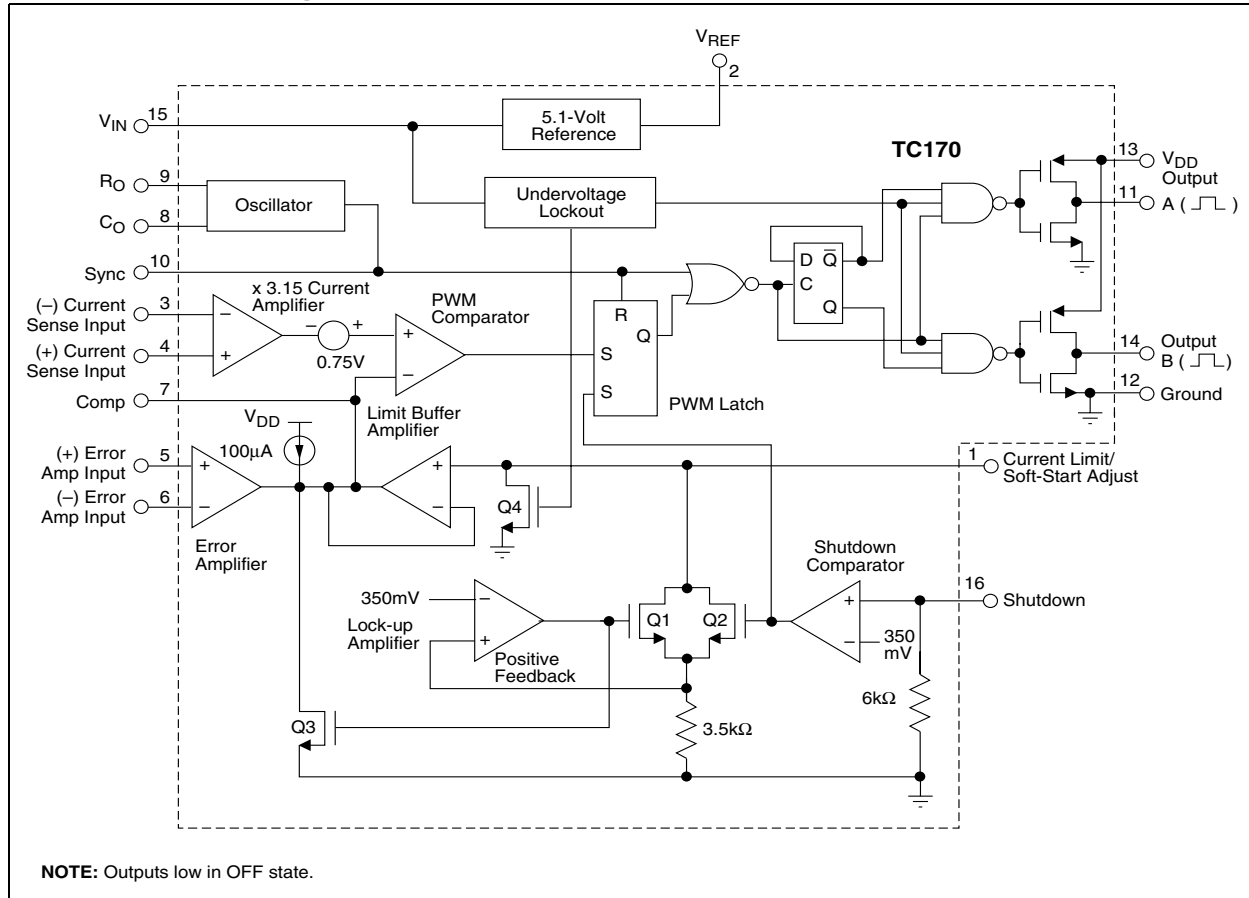

1.0 ELECTRICAL CHARACTERISTICS

Absolute Maximum Ratings*

Supply Voltage	18V
Output Voltage	V_{DD} or 18V
Analog Inputs	-0.3V to $V_S + 0.3V$
Package Thermal Resistance:	
SOIC (Wide) θ_{JA}	105°C/W
SOIC (Wide) θ_{JC}	23°C/W
PDIP (Narrow) θ_{JA}	95°C/W
PDIP (Narrow) θ_{JC}	55°C/W
Operating Temperature Range	0°C to +70°C
Storage Temperature Range	-65°C to +150°C

*Stresses above those listed under "Absolute Maximum Ratings" may cause permanent damage to the device. These are stress ratings only and functional operation of the device at these or any other conditions above those indicated in the operation sections of the specifications is not implied. Exposure to Absolute Maximum Rating conditions for extended periods may affect device reliability.

TC170 ELECTRICAL SPECIFICATIONS

Electrical Characteristics: $V_{IN} = 16V$, $R_O = 24k\Omega$, $C_O = 1nF$, $T_A = 25^\circ C$, unless otherwise noted.						
Symbol	Parameter	Min	Typ	Max	Units	Test Conditions
Reference Voltage						
V_{REF}	Reference Voltage	5	5.1	5.3	V	$I_{OUT} = 1mA$
	Line Regulation		5	15	mV	$V_{IN} = 8V$ to 16V
	Load Regulation		13	20	mV	$I_{OUT} = 1mA$ to 10mA
V_{RTC}	Temperature Coefficient		0.4	0.5	mV/°C	Over operating temperature range.
Oscillator						
F	Oscillator Frequency	35	42	46	kHz	
V_{OSC}	Voltage Stability		1.1	1.5	%/V	$V_{IN} = 8V$ to 16V
TC_{OSC}	Temperature Stability		5	10	%	Over operating temperature range.
Error Amplifier						
V_{OS}	Input Offset Voltage			±30	mV	
I_B	Input Bias Current			±1	nA	
V_{CMRR}	Common-Mode Input Voltage	0		$V_{DD} - 2V$	V	$V_{IN} = 8V$ to 16V
A_{VOL}	Open-Loop Voltage Gain	70			dB	$V_{OUT} = 1V$ to 6V
BW	Unity Gain Bandwidth		1.2		MHz	
CMRR	Common-Mode Rejection Ratio	60			dB	$V_{CMV} = 0V$ to 14V
PSRR	Power Supply Rejection Ratio	60			dB	$V_{IN} = 8V$ to 16V
Current Sense Amplifier						
A_{IAMP}	Amplifier Gain	3	3.15	3.3	V/V	Pin 3 = 0V to 1.1V
V_{DM}	Maximum Differential Input Signal			≤ 1.1	V	$V_{PIN4} - V_{PIN3}$
V_{CM}	Common-Mode Input Voltage	0		$V_{DD} - 3V$	V	
Current Limit Adjust						
V_{OS}	Current Limit Offset Voltage	0.5		1	V	
I_B	Input Bias Current			1	nA	
Shutdown Terminal						
V_{TH}	Threshold Voltage	0.3	0.35	0.4	V	
V_{IN}	Input Voltage Range	0		V_{DD}	V	
I_L	Minimum Latching Current at Pin 1	125			μA	
I_L	Maximum Nonlatching Current at Pin 1			50	μA	

TC170

TC170 ELECTRICAL SPECIFICATIONS (CONTINUED)

Electrical Characteristics: $V_{IN} = 16V$, $R_O = 24k\Omega$, $C_O = 1nF$, $T_A = 25^\circ C$, unless otherwise noted.						
Symbol	Parameter	Min	Typ	Max	Units	Test Conditions
Output Stage						
V_{DD}	Output Voltage	$V_{IN} - 0.5$	V_{IN}	$V_{IN} + 0.5$	V	Pin 13
V_{OL}	Output Low Level			0.4	V	$I_{SINK} = 20mA$
V_{OL}	Output Low Level			2	V	$I_{SINK} = 100mA$
V_{OH}	Output High Level	$V_{DD} - 1V$			V	$I_{SOURCE} = 20mA$
V_{OL}	Output High Level	$V_{DD} - 4V$			V	$I_{SOURCE} = 100mA$
t_R	Output Rise Time		50	150	nsec	$C_L = 1000pF$
t_F	Output Fall Time		50	150	nsec	$C_L = 1000pF$
Undervoltage Lockout						
	Start-Up	7.15	7.7	8.25	V	Threshold
	Threshold Hysteresis	0.5	0.75	1	V	
Supply						
I_S	Standby Supply Current		2.7	3.8	mA	

2.0 PIN DESCRIPTIONS

The descriptions of the pins are listed in Table 2-1.

TABLE 2-1: PIN FUNCTION TABLE

Pin No. (16-Pin PDIP, SOIC)	Symbol	Description
1	SOFT START/I _{LIM}	Soft Start Adjust/Current Limit. For setting the peak current threshold of sense inputs (pins 3 and 4). Second function of this pin is Soft-Start Adjust.
2	V _{REF} OUT	Reference supply output of 5.1 volts. It can supply a minimum of 10mA.
3	-I _{SENSE} IN	-Current Sense Input. Inverting input for sensing peak current of the pass transistor through series sense current monitor resistor.
4	+I _{SENSE} IN	+Current Sense Input. Non-inverting input used in conjunction with pin 3. This senses the positive end of current monitor resistor.
5	+ERROR AMP IN	+Error Amp In. Non-inverting input for output voltage regulation.
6	-ERROR AMP IN	-Error Amp In. Inverting input of the amplifier for the reference voltage.
7	COMPTR	For compensation of the feedback loop response.
8	C _O	Timing capacitor (C _O) input to set oscillator frequency in conjunction with pin 9, R _O , resistor input. Second function is for setting crossover dead time of pin 11 and 14 outputs.
9	R _O	Timing resistor (R _O) input to set oscillator frequency by setting constant current charge rate to charge capacitor C _O .
10	SYNC	For PWM controller oscillator synchronization of two or more controllers. Or as a clock input to sync oscillator from external signal.
11	OUTPUT A	A output drive of phase A from push pull transistors.
12	GND	Ground return for all input and output pins.
13	V _{DD}	Supplies power to operate the output drivers only.
14	OUTPUT B	Output of phase B from push pull transistors.
15	V _{IN}	Voltage bias supply for all TC170 circuits except the output transistors.
16	SHDN	Input pin to disable both output drives to 0V OFF.

3.0 DETAILED DESCRIPTION

3.1 Peak Current Limit Setup

Resistors R1 and R2 at the current limit input (pin 1) set the TC170 peak current limit (Figure 3-1). The potential at pin 1 is easily calculated:

$$V1 = V_{REF} \frac{R2}{R1 + R2}$$

R1 should be selected first. The shutdown circuit feature is not latched for $(V_{REF} - 0.35)/R1 < 50\mu\text{A}$ and is latched for currents greater than $125\mu\text{A}$.

The error amplifier output voltage is clamped from going above V1 through the limit buffer amplifier. Peak current is sensed by RS and amplified by the current amplifier which has a fixed gain of 3.15.

I_{PCL} , the peak current limit, is the current that causes the PWM comparator noninverting input to exceed V1, the potential at the inverting input. Once the comparator trip point is exceeded, both outputs are disabled.

I_{PCL} is easily calculated:

$$I_{PCL} = \frac{V1 - 0.75V}{3.15 (RS)}$$

where:

$$V1 = V_{REF} \frac{R2}{R1 + R2}$$

V_{REF} = Internal voltage reference = 5.1V

3.15 = Gain of current-sense amplifier

0.75V = Current limit offset

Both driver outputs (pins 11 and 14) are OFF (LOW) when the peak current limit is exceeded. When the sensed current goes below I_{PCL} , the circuit operates normally.

3.2 Output Shutdown

The TC170 outputs can be turned OFF quickly through the shutdown input (pin 16). A signal greater than 350mV at pin 16 forces the shutdown comparator output HIGH. The PWM latch is held set, disabling the outputs.

Q2 is also turned ON. If $V_{REF}/R1$ is greater than $125\mu\text{A}$, positive feedback through the lockup amplifier and Q1 keeps the inverting PWM comparator inverting input below 0.75V. Q3 remains ON even after the shutdown input signal is removed, because of the positive feedback. The state can be cleared only through a power-up cycle. Outputs will be disabled whenever the potential at pin 1 is below 0.75V.

The shutdown terminal gives a fast, direct way to disable the TC170 output transistors. System protection and remote shutdown applications are possible.

The input pulse to pin 16 should be at least 500nsec wide and have an amplitude of at least 1V in order to get the minimum propagation delay from input to output. If these parameters are met, the delay should be less than 600nsec at 25°C; however, the delay time will increase as the device temperature rises.

3.3 Soft Restart From Shutdown

A soft restart can be programmed if nonlatched shutdown operation is used.

A capacitor at pin 1 will cause a gradual increase in potential toward V1. When the voltage at pin 1 reaches 0.75V, the PWM latch set input is removed and the circuit establishes a regulated output voltage. The soft-start operation forces the PWM output drivers to initially operate with minimum duty cycle and low peak currents.

Even if a soft start is not required, it is necessary to insert a capacitor between pin 1 and ground if the current I_L is greater than $125\mu\text{A}$. This capacitor will prevent "noise triggering" of the latch, yet minimize the soft-start effect.

3.4 Soft-Start Power-Up

During power-up, a capacitor at R1, R2 initiates a soft-start cycle. As the input voltage (pin 15) exceeds the undervoltage lockout potential (7.7V), Q4 is turned OFF, ending undervoltage lockout. Whenever the PWM comparator inverting input is below 0.5V, both outputs are disabled.

When the undervoltage lockout level is passed, the capacitor begins to charge. The PWM duty cycle increases until the operating output voltage is reached. Soft-start operation forces the PWM output drivers to initially operate with minimum duty cycle and low peak current.

3.5 Current-Sense Amplifier

The current-sense amplifier operates at a fixed gain of 3.15. Maximum differential input voltage ($V_{PIN4} - V_{PIN3}$) is 1.1V. Common-mode input voltage range is 0V to $V_{IN} - 3V$.

Resistive-sensing methods are shown in Figure 3-2 and Figure 3-3. In Figure 3-2, a simple RC filter limits transient voltage spikes at pin 4, caused by external output transistor-collector capacitance. Transformer coupling (Figure 3-4) offers isolation and better power efficiency, but cost and complexity increase.

In order to minimize the propagation delay from the input to the current amplifier to the output terminals, the current ramp should be in the order of 1μsec in width (min). Typical time delay values are in the 300 to 400nsec region at 25°C. The delay time increases with device temperature so that at 50°C, the delay times may be increased by as much as 100nsec.

FIGURE 3-1: R1 AND R2 SET MAXIMUM PEAK OUTPUT CURRENT

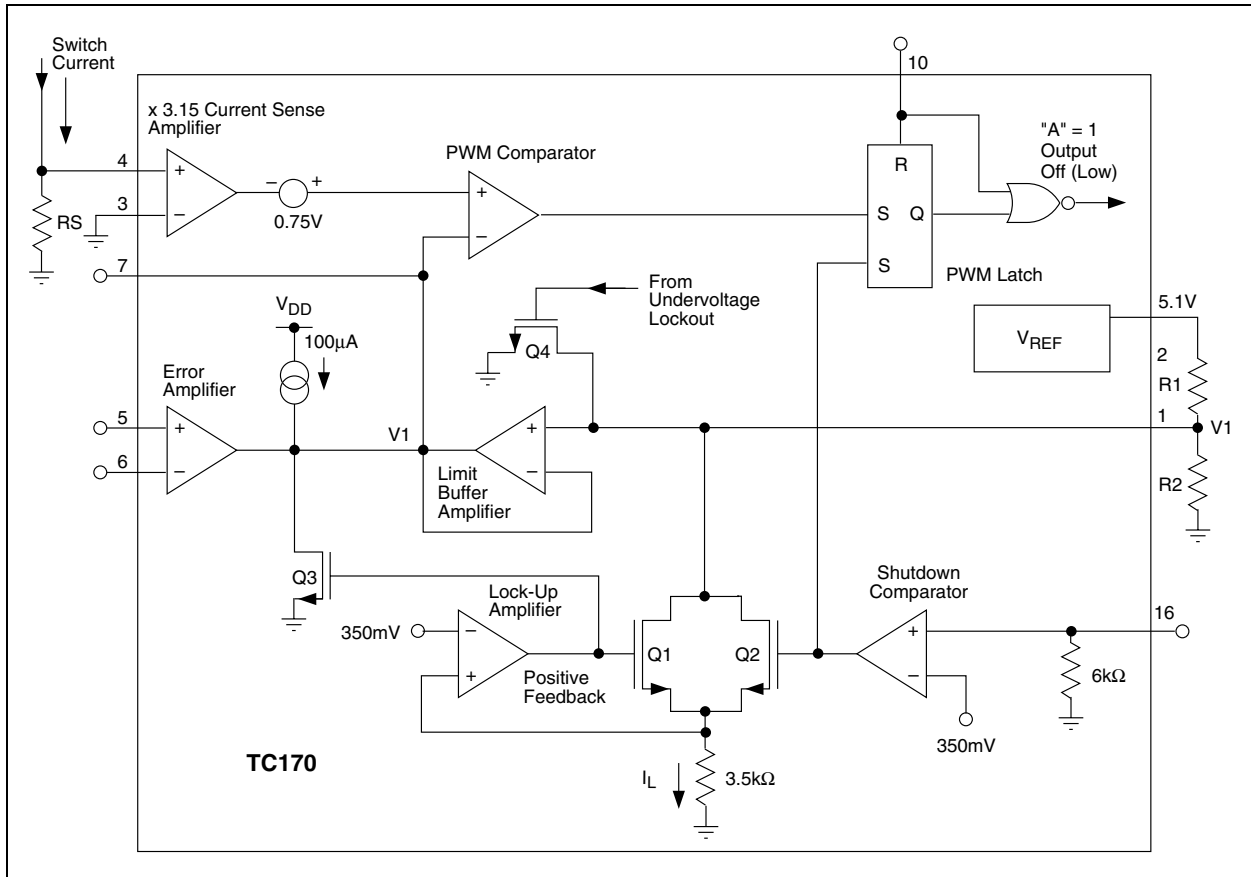

FIGURE 3-2: GROUND REFERENCE RESISTIVE SENSING

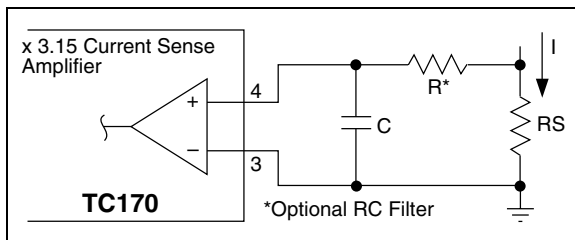
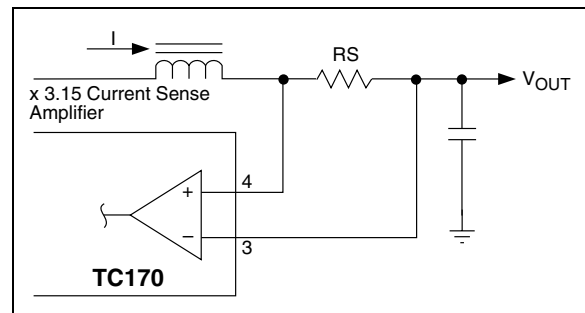
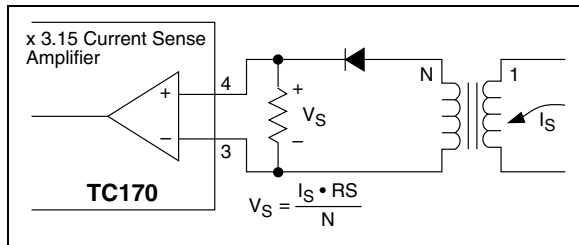

FIGURE 3-3: ABOVE GROUND RESISTIVE SENSING



TC170

FIGURE 3-4: TRANSFORMER ISOLATED CURRENT SENSE



3.6 Undervoltage Lockout

The undervoltage lockout circuit forces the TC170 outputs OFF (low) if the supply voltage is below 7.7V. Threshold hysteresis is 0.75V and guarantees clean, jitter-free turn-on and turnoff points. The hysteresis also reduces capacitive filtering requirements at the PWM controller supply input (pin 15).

3.7 Circuit Synchronization

Current-mode-controlled power supplies can be operated in parallel with a common load. Paralleled converters will equally share the load current. Voltage-mode controllers unequally share the load current, decreasing system reliability.

Two or more TC170 controllers can be slaved together for parallel operation. Circuits can operate from a master TC170 internal oscillator with an external driver (Figure 3-5). Devices can also be slaved to an external oscillator (Figure 3-6). Disable internal slave device oscillators by grounding pin 8. Slave controllers derive an oscillator from the bidirectional synchronization output signal at pin 10.

Pin 10 is bidirectional in that it is intended to be both a sync output and input. This is accomplished by making the output driver "weak." This is advantageous in that it eliminates an additional pin from the package but does not enable the device to directly drive another device. In order to make it an effective driver, a buffer is required (Figure 3-5). In order to use pin 10 as a sync input, it is necessary to overcome the internal driver. This requires a pulse with an amplitude equal to V_{IN} . Since V_{IN} must be above 8.25V for the undervoltage lockout to be disabled, a CMOS or open-collector TTL driver should be used.

FIGURE 3-5: MASTER/SLAVE PARALLEL OPERATION

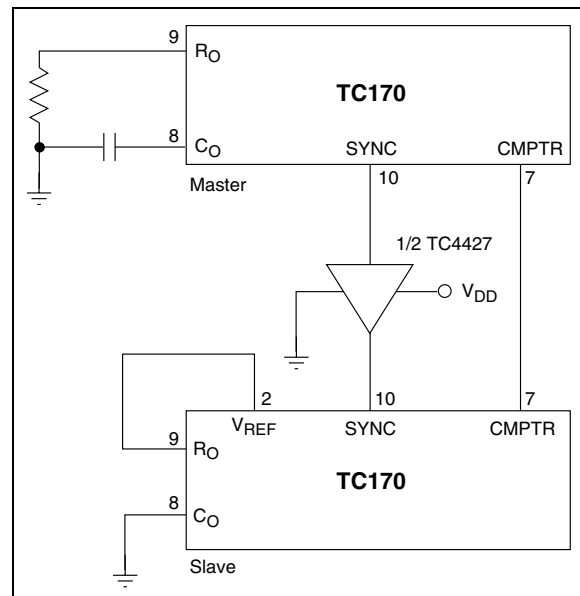

FIGURE 3-6: EXTERNAL CLOCK SYNCHRONIZATION

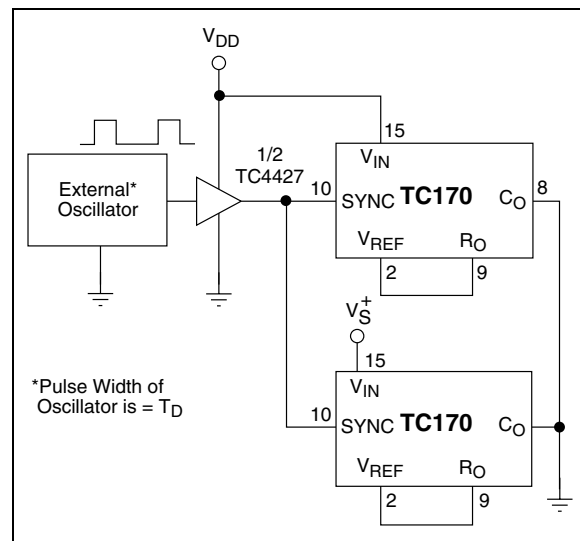
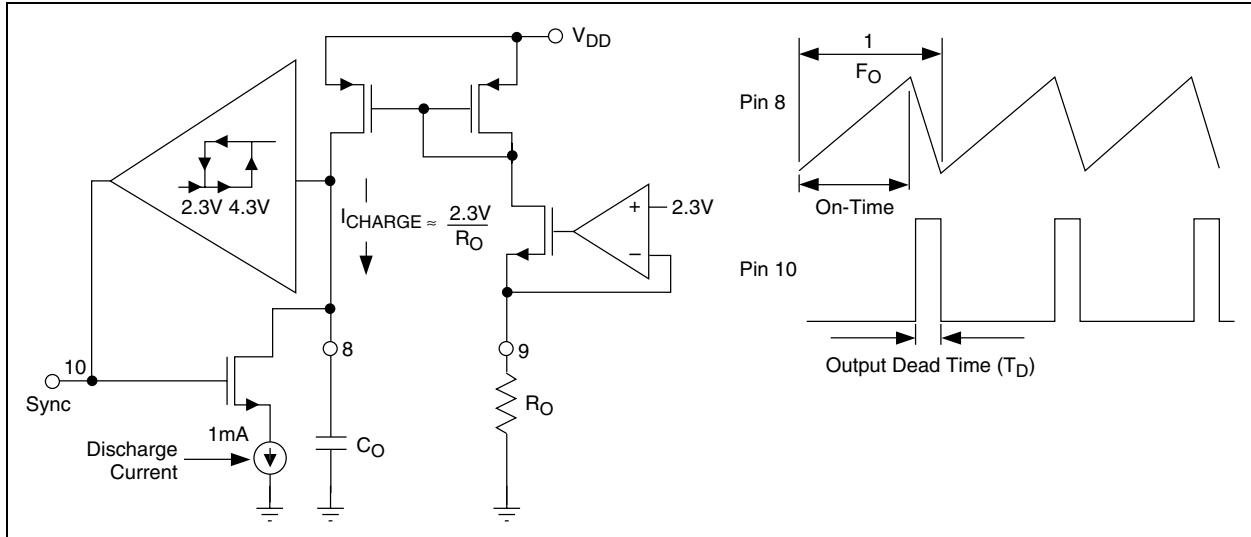

FIGURE 3-7: OSCILLATOR CIRCUIT



3.8 Oscillator Frequency and Output Dead Time

The oscillator frequency for $R_O = 24k\Omega$ and $C_O = 1000pF$ is:

$$F_O = \left[\frac{1.27}{R_O C_O} - \frac{2800}{R_O^2 C_O} \right] \frac{C_O}{C_O + 150 \times 10^{-12}}$$

where: R_O = Oscillator Resistor (Ω)
 C_O = Oscillator Capacitor (F)
 F_O = Oscillator Frequency (Hz)

The oscillator resistor can range from 5k Ω to 50k Ω .

Oscillator capacitor can range from 250pF to 1000pF. Figure 3-8 shows typical operation for various resistance and capacitance values.

During transitions between the two outputs, simultaneous conduction is prevented. Oscillator fall time controls the output off, or dead time (Figure 3-7).

Dead time is approximately:

$$T_D = \frac{2000 [C_O]}{1 - \left(\frac{2.3}{R_O} \right)}$$

where: R_O = Oscillator Resistor (k Ω)
 C_O = Oscillator Capacitor (pF)
 T_D = Output Dead Time (sec)

Maximum possible duty cycle is set by the dead time.

FIGURE 3-8: OSCILLATOR FREQUENCY VS. OSCILLATOR RESISTANCE

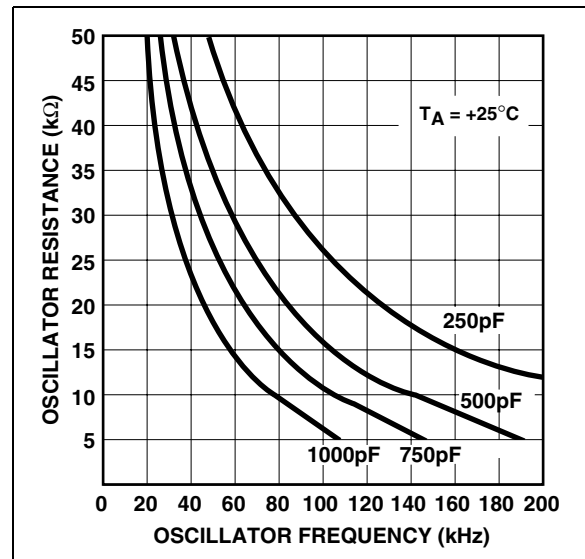

TC170

4.0 TYPICAL CHARACTERISTICS

Note: The graphs and tables provided following this note are a statistical summary based on a limited number of samples and are provided for informational purposes only. The performance characteristics listed herein are not tested or guaranteed. In some graphs or tables, the data presented may be outside the specified operating range (e.g., outside specified power supply range) and therefore outside the warranted range.

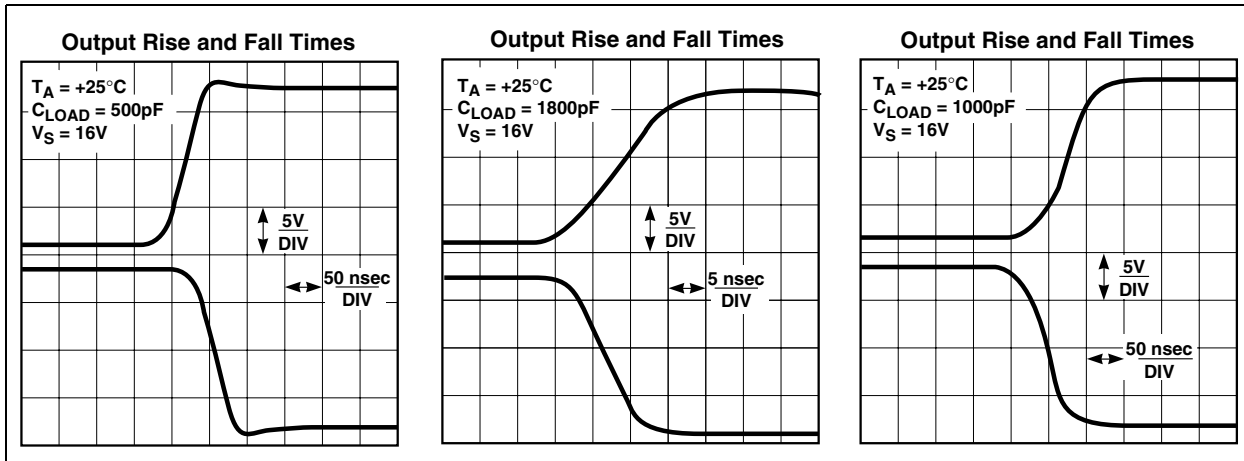

5.0 PACKAGING INFORMATION

5.1 Package Marking Information

Package marking data not available at this time.

5.2 Taping Form

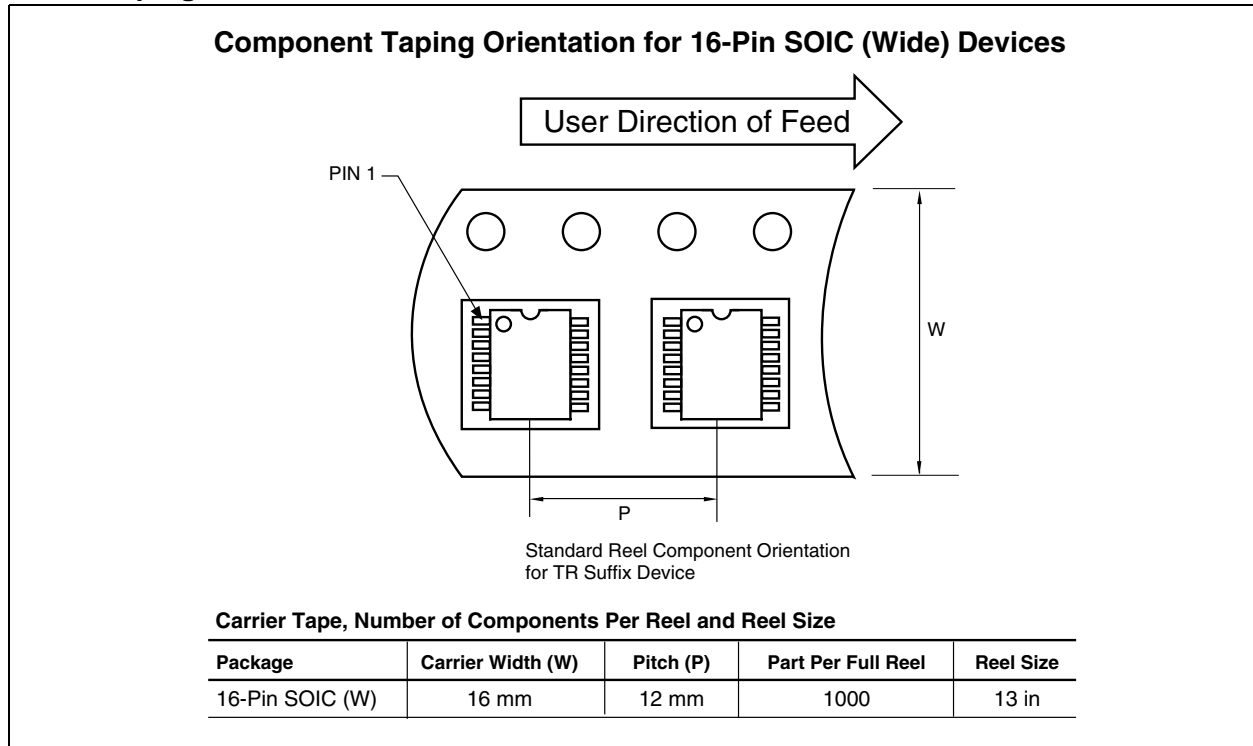

TC170

5.3 Package Dimensions

16-Pin PDIP (Narrow)

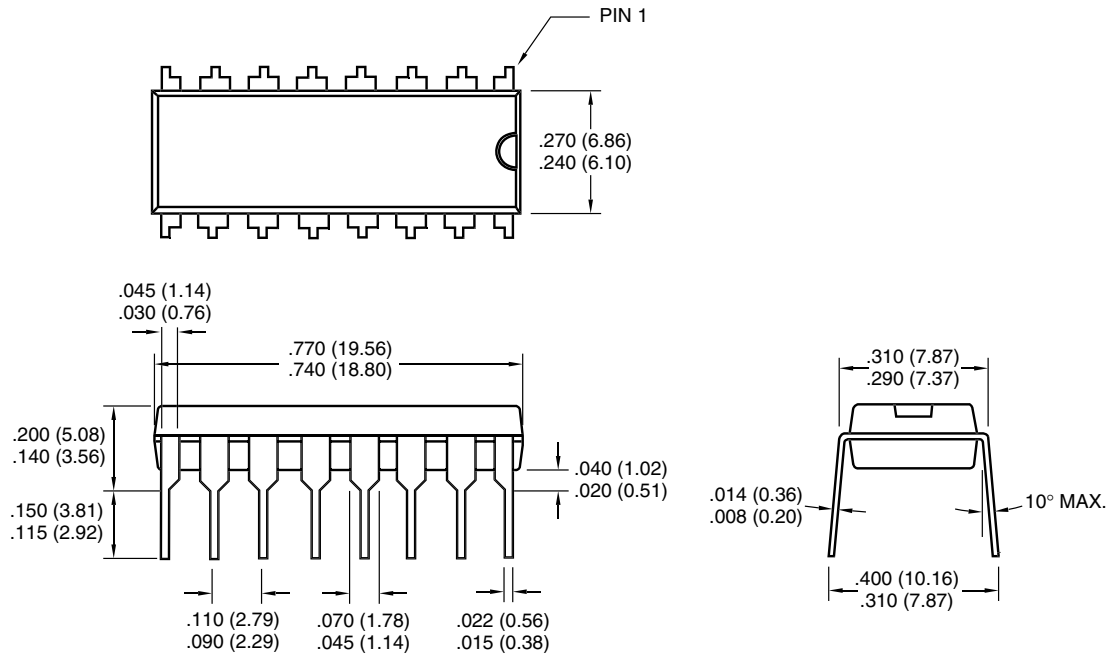

Dimensions: inches (mm)

16-Pin SOIC (Wide)

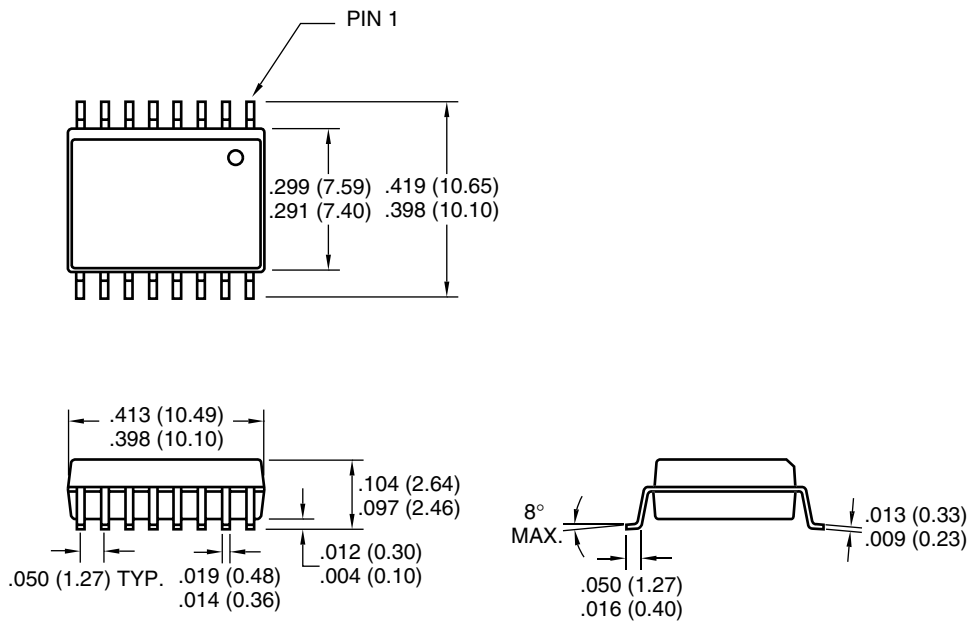

Dimensions: inches (mm)

Sales and Support

Data Sheets

Products supported by a preliminary Data Sheet may have an errata sheet describing minor operational differences and recommended workarounds. To determine if an errata sheet exists for a particular device, please contact one of the following:

1. Your local Microchip sales office
2. The Microchip Corporate Literature Center U.S. FAX: (480) 792-7277
3. The Microchip Worldwide Site (www.microchip.com)

Please specify which device, revision of silicon and Data Sheet (include Literature #) you are using.

New Customer Notification System

Register on our web site (www.microchip.com/cn) to receive the most current information on our products.

TC170

NOTES:

Information contained in this publication regarding device applications and the like is intended through suggestion only and may be superseded by updates. It is your responsibility to ensure that your application meets with your specifications. No representation or warranty is given and no liability is assumed by Microchip Technology Incorporated with respect to the accuracy or use of such information, or infringement of patents or other intellectual property rights arising from such use or otherwise. Use of Microchip's products as critical components in life support systems is not authorized except with express written approval by Microchip. No licenses are conveyed, implicitly or otherwise, under any intellectual property rights.

Trademarks

The Microchip name and logo, the Microchip logo, FilterLab, KEELOQ, microID, MPLAB, PIC, PICmicro, PICMASTER, PICSTART, PRO MATE, SEEVAL and The Embedded Control Solutions Company are registered trademarks of Microchip Technology Incorporated in the U.S.A. and other countries.

dsPIC, ECONOMONITOR, FanSense, FlexROM, fuzzyLAB, In-Circuit Serial Programming, ICSP, ICEPIC, microPort, Migratable Memory, MPASM, MPLIB, MPLINK, MPSIM, MXDEV, MXLAB, PICC, PICDEM, PICDEM.net, rPIC, Select Mode and Total Endurance are trademarks of Microchip Technology Incorporated in the U.S.A.

Serialized Quick Turn Programming (SQTP) is a service mark of Microchip Technology Incorporated in the U.S.A.

All other trademarks mentioned herein are property of their respective companies.

© 2002, Microchip Technology Incorporated, Printed in the U.S.A., All Rights Reserved.

 Printed on recycled paper.



Microchip received QS-9000 quality system certification for its worldwide headquarters, design and wafer fabrication facilities in Chandler and Tempe, Arizona in July 1999 and Mountain View, California in March 2002. The Company's quality system processes and procedures are QS-9000 compliant for its PICmicro® 8-bit MCUs, KEELOQ® code hopping devices, Serial EEPROMs, microperipherals, non-volatile memory and analog products. In addition, Microchip's quality system for the design and manufacture of development systems is ISO 9001 certified.



MICROCHIP

WORLDWIDE SALES AND SERVICE

AMERICAS

Corporate Office

2355 West Chandler Blvd.
Chandler, AZ 85224-6199
Tel: 480-792-7200 Fax: 480-792-7277
Technical Support: 480-792-7627
Web Address: <http://www.microchip.com>

Rocky Mountain

2355 West Chandler Blvd.
Chandler, AZ 85224-6199
Tel: 480-792-7966 Fax: 480-792-7456

Atlanta

500 Sugar Mill Road, Suite 200B
Atlanta, GA 30350
Tel: 770-640-0034 Fax: 770-640-0307

Boston

2 Lan Drive, Suite 120
Westford, MA 01886
Tel: 978-692-3848 Fax: 978-692-3821

Chicago

333 Pierce Road, Suite 180
Itasca, IL 60143
Tel: 630-285-0071 Fax: 630-285-0075

Dallas

4570 Westgrove Drive, Suite 160
Addison, TX 75001
Tel: 972-818-7423 Fax: 972-818-2924

Detroit

Tri-Atria Office Building
32255 Northwestern Highway, Suite 190
Farmington Hills, MI 48334
Tel: 248-538-2250 Fax: 248-538-2260

Kokomo

2767 S. Albright Road
Kokomo, Indiana 46902
Tel: 765-864-8360 Fax: 765-864-8387

Los Angeles

18201 Von Karman, Suite 1090
Irvine, CA 92612
Tel: 949-263-1888 Fax: 949-263-1338

New York

150 Motor Parkway, Suite 202
Hauppauge, NY 11788
Tel: 631-273-5305 Fax: 631-273-5335

San Jose

Microchip Technology Inc.
2107 North First Street, Suite 590
San Jose, CA 95131
Tel: 408-436-7950 Fax: 408-436-7955

Toronto

6285 Northam Drive, Suite 108
Mississauga, Ontario L4V 1X5, Canada
Tel: 905-673-0699 Fax: 905-673-6509

ASIA/PACIFIC

Australia

Microchip Technology Australia Pty Ltd
Suite 22, 41 Rawson Street
Epping 2121, NSW
Australia
Tel: 61-2-9868-6733 Fax: 61-2-9868-6755

China - Beijing

Microchip Technology Consulting (Shanghai)
Co., Ltd., Beijing Liaison Office
Unit 915
Bei Hai Wan Tai Bldg.
No. 6 Chaoyangmen Beidajie
Beijing, 100027, No. China
Tel: 86-10-85282100 Fax: 86-10-85282104

China - Chengdu

Microchip Technology Consulting (Shanghai)
Co., Ltd., Chengdu Liaison Office
Rm. 2401, 24th Floor,
Ming Xing Financial Tower
No. 88 TIDU Street
Chengdu 610016, China
Tel: 86-28-6766200 Fax: 86-28-6766599

China - Fuzhou

Microchip Technology Consulting (Shanghai)
Co., Ltd., Fuzhou Liaison Office
Unit 28F, World Trade Plaza
No. 71 Wusi Road
Fuzhou 350001, China
Tel: 86-591-7503506 Fax: 86-591-7503521

China - Shanghai

Microchip Technology Consulting (Shanghai)
Co., Ltd.
Room 701, Bldg. B
Far East International Plaza
No. 317 Xian Xia Road
Shanghai, 200051
Tel: 86-21-6275-5700 Fax: 86-21-6275-5060

China - Shenzhen

Microchip Technology Consulting (Shanghai)
Co., Ltd., Shenzhen Liaison Office
Rm. 1315, 13/F, Shenzhen Kerry Centre,
Renminnan Lu
Shenzhen 518001, China
Tel: 86-755-2350361 Fax: 86-755-2366086

Hong Kong

Microchip Technology Hongkong Ltd.
Unit 901-6, Tower 2, Metroplaza
223 Hing Fong Road
Kwai Fong, N.T., Hong Kong
Tel: 852-2401-1200 Fax: 852-2401-3431

India

Microchip Technology Inc.
India Liaison Office
Divyasree Chambers
1 Floor, Wing A (A3/A4)
No. 11, O'Shaugnessey Road
Bangalore, 560 025, India
Tel: 91-80-2290061 Fax: 91-80-2290062

Japan

Microchip Technology Japan K.K.
Benex S-1 6F
3-18-20, Shinyokohama
Kohoku-Ku, Yokohama-shi
Kanagawa, 222-0033, Japan
Tel: 81-45-471-6166 Fax: 81-45-471-6122

Korea

Microchip Technology Korea
168-1, Youngbo Bldg. 3 Floor
Samsung-Dong, Kangnam-Ku
Seoul, Korea 135-882
Tel: 82-2-554-7200 Fax: 82-2-558-5934

Singapore

Microchip Technology Singapore Pte Ltd.
200 Middle Road
#07-02 Prime Centre
Singapore, 188980
Tel: 65-6334-8870 Fax: 65-6334-8850

Taiwan

Microchip Technology Taiwan
11F-3, No. 207
Tung Hua North Road
Taipei, 105, Taiwan
Tel: 886-2-2717-7175 Fax: 886-2-2545-0139

EUROPE

Denmark

Microchip Technology Nordic ApS
Regus Business Centre
Lautrup høj 1-3
Ballerup DK-2750 Denmark
Tel: 45 4420 9895 Fax: 45 4420 9910

France

Microchip Technology SARL
Parc d'Activite du Moulin de Massy
43 Rue du Saule Trapu
Batiment A - 1er Etage
91300 Massy, France
Tel: 33-1-69-53-63-20 Fax: 33-1-69-30-90-79

Germany

Microchip Technology GmbH
Gustav-Heinemann Ring 125
D-81739 Munich, Germany
Tel: 49-89-627-144 0 Fax: 49-89-627-144-44

Italy

Microchip Technology SRL
Centro Direzionale Colleoni
Palazzo Taurus 1 V. Le Colleoni 1
20041 Agrate Brianza
Milan, Italy
Tel: 39-039-65791-1 Fax: 39-039-6899883

United Kingdom

Arizona Microchip Technology Ltd.
505 Eskdale Road
Winnersh Triangle
Wokingham
Berkshire, England RG41 5TU
Tel: 44 118 921 5869 Fax: 44-118 921-5820

03/01/02

