

Toshiba Bipolar Linear Integrated Circuit Multi-Chip

TA8493F, TA8493AF, TA8493BF

3-Phase Full Wave Brushless DC Motor Driver IC for CD-ROM Drives

These 3-phase, full-wave, brushless DC motor driver ICs have been developed for use in CD-ROM drive spindle motors. The TA8493F/ AF/ BF contain in its upper stage a discrete power transistor (P-ch-MOS) and uses direct PWM control system, which enables the IC to provide superior thermal efficiency.

Furthermore, the multi-chip structure of this device facilitates dispersion of the heat generated inside the package, making it possible to suppress heat concentration.

Features

- Multi-chip structure (3 × 2SJ465 chips built-in)
- Direct PWM control system
- Drive system: 120° drive system (TA8493F/BF)
: 180° drive system (TA8493AF)
- Built-in current limiter: $I_{LIM} = 0.7 \text{ A (typ.)}$ (at $R_F = 0.33 \Omega$)
- Built-in reversing brake/short brake functions
- FG signal output (using hall element output signal)
- Built-in hall bias
- Built-in thermal shutdown circuit
- Package: MFP-30

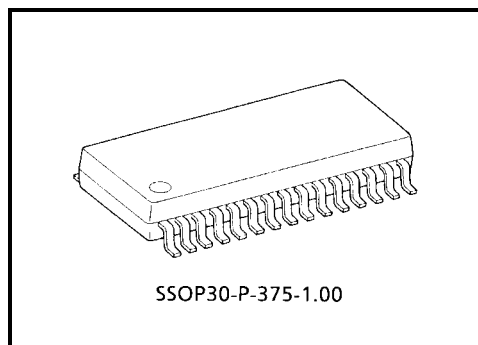

Weight: 0.63 g (typ.)

Block Diagram

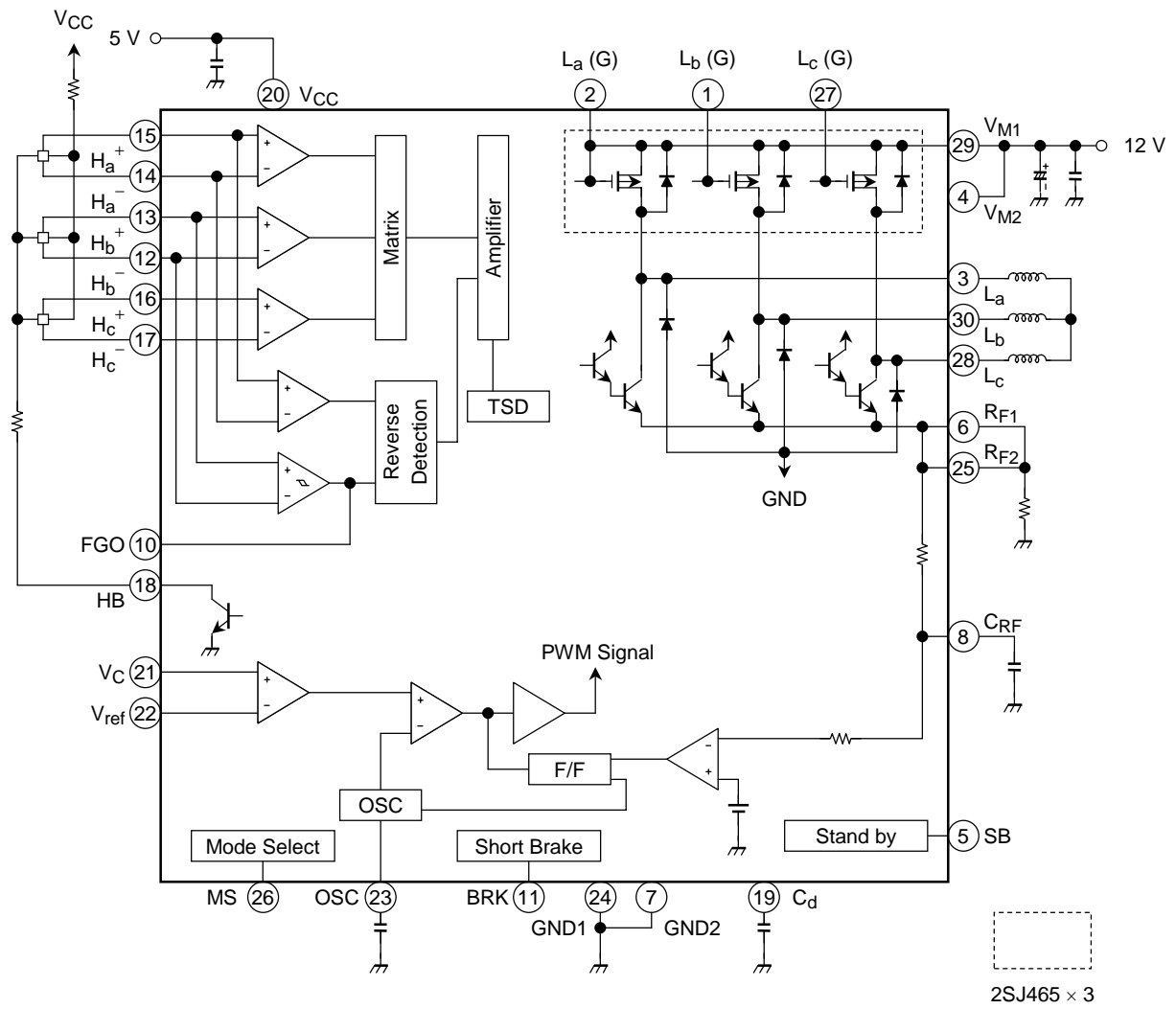

9 pin: N.C.

PIN Assignment

Terminal No.	Terminal Symbol	Function	Remarks
1	L _b (G)	b-phase upper side power transistor (base) output terminal	Keep open.
2	L _a (G)	a-phase upper side power transistor (base) output terminal	Keep open.
3	L _a	a-phase output terminal	Connect to the coil.
4	V _{M2}	Supply voltage terminal for motor drive	Connect to V _{M1} externally.
5	SB	RUN/STOP control terminal	H: RUN, L: STOP
6	R _{F1}	Output current detection terminal	Sets limiter current value. Connect to R _{F2} externally and between this terminal and GND.
7	GND2	GND	—
8	C _{RF}	Output current filter terminal	Connect a capacitor between this terminal and GND.
9	N.C.		
10	FGO	FG amplifier output terminal	Outputs a signal whose frequency is determined by the CD rotation frequency.
11	BRK	Brake mode select terminal	Output mode when V _C > V _{ref}
12	H _b ⁻	b-phase negative hall signal input terminal	Connect to hall element output terminal.
13	H _b ⁺	b-phase positive hall signal input terminal	Connect to hall element output terminal.
14	H _a ⁻	a-phase negative hall signal input terminal	Connect to hall element output terminal.
15	H _a ⁺	a-phase positive hall signal input terminal	Connect to hall element output terminal.
16	H _c ⁺	c-phase positive hall signal input terminal	Connect to hall element output terminal.
17	H _c ⁻	a-phase negative hall signal input terminal	Connect to hall element output terminal.
18	HB	Hall element bias terminal	Open collector output. Connect to the negative side of hall element bias line.
19	C _d	Forward/reverse changeover gain adjustment terminal	Adjust a rotation direction changeover gain
20	V _{CC}	Supply voltage terminal for control circuits	V _{CC (opr)} = 4.5 to 5.5 V
21	V _C	Control amplifier input terminal	Use the control signal as input.
22	V _{ref}	Control amplifier reference voltage input terminal	Use the reference voltage for the control amplifier as input.
23	OSC	Triangular wave oscillation terminal	Connect a capacitor between this terminal and GND.
24	GND1	GND	—
25	R _{F2}	Output current detection terminal	Sets limiter current value. Connect to R _{F1} externally and between this terminal and GND.
26	MS	Mode select terminal	Determines output mode.
27	L _c (G)	c-phase upper side power transistor (base) output terminal	Keep open.
28	L _c	c-phase output terminal	Connect to the coil.
29	V _{M1}	Supply voltage terminal for motor drive	Connect to V _{M2} externally.
30	L _b	b-phase output terminal	Connect to the coil.

Absolute Maximum Ratings (Ta = 25°C)

Characteristics	Symbol	Rating	Unit
Power Supply Voltage	V _{CC}	7	V
	V _M	16	
Output Current	I _O	1.5	A
Power Dissipation	P _D (Note1)	1.0	W
Junction Temperature	T _j	150	°C
Operating Temperature	T _{opr}	-20 to 75	°C
Storage Temperature	T _{stg}	-55 to 150	°C

Note1: unmounted

Operating Voltage Range

Characteristics	Symbol	Operating Range	Unit
Power Supply Voltage	V _{CC}	4.5 to 5.5	V
	V _M	10 to 14	

Electrical Characteristics (V_{CC} = 5 V, V_M = 12 V, Ta = 25°C)

Characteristics		Symbol	Test Circuit	Test Condition	Min	Typ.	Max	Unit
Supply Voltage		I _{CC1}	1	Stop mode	—	0.3	0.8	mA
		I _{CC2}		Run mode, output open	—	7	15	
Hall Amp.	Input Current	I _{INH}	2	V _{CMRH} = 2.5 V, (sink current)	—	—	2	μA
	Common Mode Input Voltage Range	V _{CMRH}		—	1.5	—	4.0	V
	Input Amplitude	V _H		—	100	—	—	mV _{p-p}
Hall Element Bias Saturation Voltage		V _{HB}	2	I _{HB} = 10 mA	—	1.3	2.0	V
Control Amp.	Common Mode Input Voltage Range	V _{CMRC}	2	—	0.5	—	4.0	V
	Input Current	I _{INC}		V _C = V _{ref} = 1.65 V, (source current)	—	—	5.0	μA
	Dead Zone Voltage Width	V _{DZ}	—	V _{ref} = 1.65 V, R _F = 0.33 Ω (Note2)	—	100	—	mV
	Input Offset Voltage	ΔV _{OFF} (F)	2	CW mode, V _{ref} = 1.65 V, R _F = 0.33 Ω	20	50	150	
ΔV _{OFF} (R)		CCW mode, V _{ref} = 1.65 V, R _F = 0.33 Ω		20	50	150		
Current Limit Amp.	Limit Current	I _{LIM}	—	R _F = 0.33 Ω (Note2)	—	700	—	mA
		V _{LIM}	3	—	0.25	0.3	0.35	V
RUN/STOP Control Circuit	Input Voltage (H)	V _{INS} (H)	1	(RUN)	3.0	—	V _{CC}	V
	Input Voltage (L)	V _{INS} (L)		(STOP)	GND	—	1.0	
	Input Current	I _{INS} (L)		V _{INS} = GND, (source current)	—	—	1	μA

Note2: this is not tested.

Characteristics		Symbol	Test Circuit	Test Condition	Min	Typ.	Max	Unit
Output Circuit	Output Resistance (upper side)	$R_{ON} (U)$	4	$I_O = 0.6 A$	—	0.5	1.0	Ω
	Saturation Voltage (lower side)	$V_{SAT} (L)$		$I_O = 0.6 A$	—	0.4	0.8	V
	Cut-off Current (upper side)	$I_L (U)$	5	$V_L = 16 V$	—	—	10	μA
	Cut-off Current (lower side)	$I_L (L)$		$V_L = 16 V$	—	—	10	
Mode Select Circuit	Input Voltage (H)	$V_{MS} (H)$	6	CCW mode $V_C > V_{ref}$, BRK: L	3.0	—	V_{CC}	V
	Input Voltage (L)	$V_{MS} (L)$		Reversing brake mode $V_C > V_{ref}$, BRK: L	—	—	0.5	
	Input Current	I_{INMS}		$V_{MS} = GND$, (source current)	—	—	1	μA
FG Amp.	Hysteresis Voltage	V_{HYS}	8	—	5	20	45	mV_{p-p}
	Output Voltage (H)	$V_{OFG} (H)$	7	Source current: $10 \mu A$	$V_{CC} - 0.5$	—	—	V
	Output Voltage (L)	$V_{OFG} (L)$		Sink current: $10 \mu A$	—	—	0.5	
Short Brake Circuit	Input Voltage (H)	$V_{BRK} (H)$	6	—	3.0	—	V_{CC}	V
	Input Voltage (L)	$V_{BRK} (L)$		—	—	—	0.5	
	Input Current	I_{INBRK}		$V_{BRK} = GND$, (source current)	—	—	—	1
Triangular Oscillation Circuit	Oscillation Frequency	f_{OSC}	—	$C = 560 pF$ (Note2)	—	39	—	kHz
Thermal Shut-down Operating Temperature		TSD	—	Junction temperature (according to design specification) (Note2)	—	175	—	$^{\circ}C$

Note2: this is not tested.

Function Table

			Forward			Reverse		
H _a	H _b	H _c	L _a	L _b	L _c	L _a	L _b	L _c
H	L	L	H	L	M	L	H	M
H	H	L	H	M	L	L	M	H
L	H	L	M	H	L	M	L	H
L	H	H	L	H	M	H	L	M
L	L	H	L	M	H	H	M	L
H	L	H	M	L	H	M	H	L

<Forward>

$$L_a = -(H_c - H_a)$$

$$L_b = -(H_a - H_b)$$

$$L_c = -(H_b - H_c)$$

<Reverse>

$$L_a = (H_c - H_a)$$

$$L_b = (H_a - H_b)$$

$$L_c = (H_b - H_c)$$

Timing Diagram

<Forward>

(TA8493F/BF)

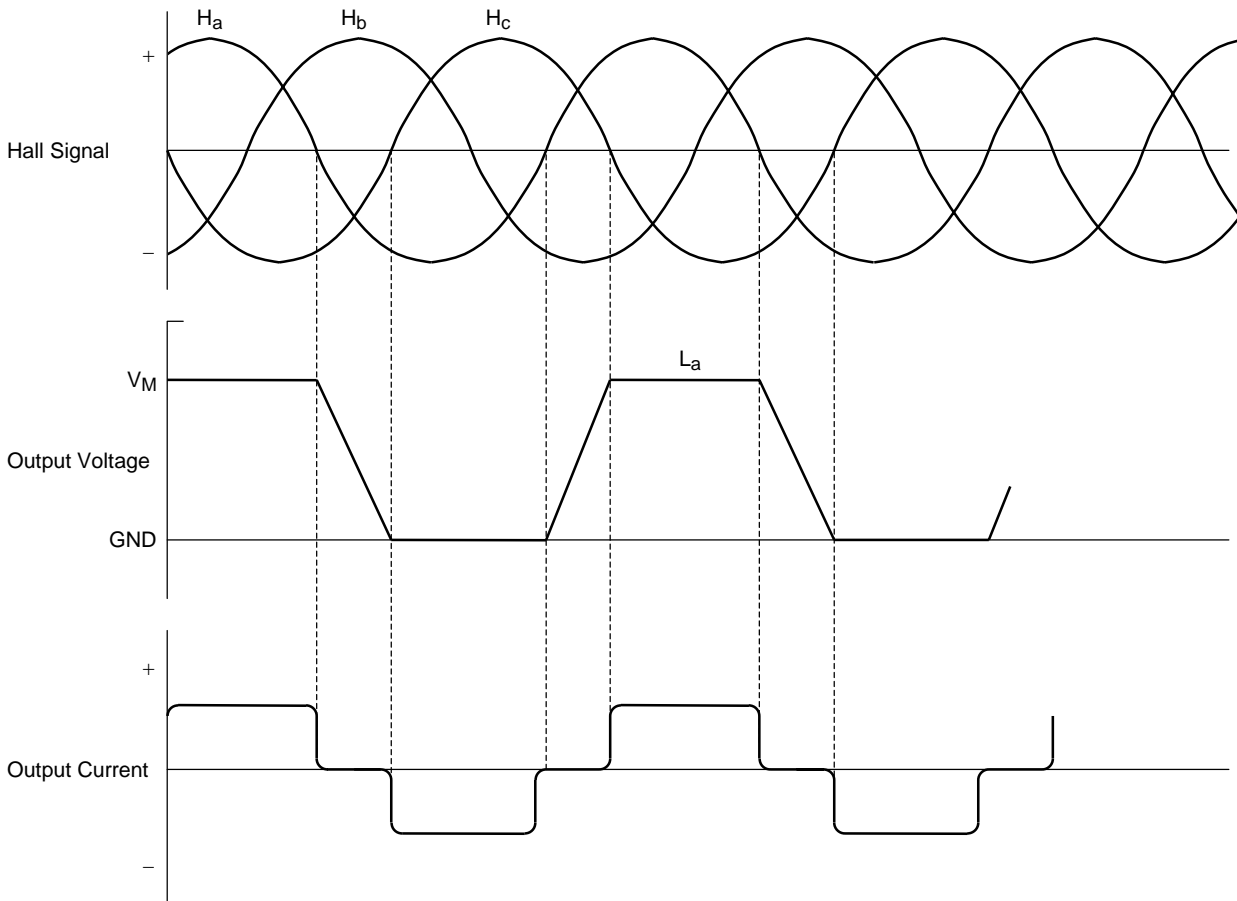

(TA8493AF)

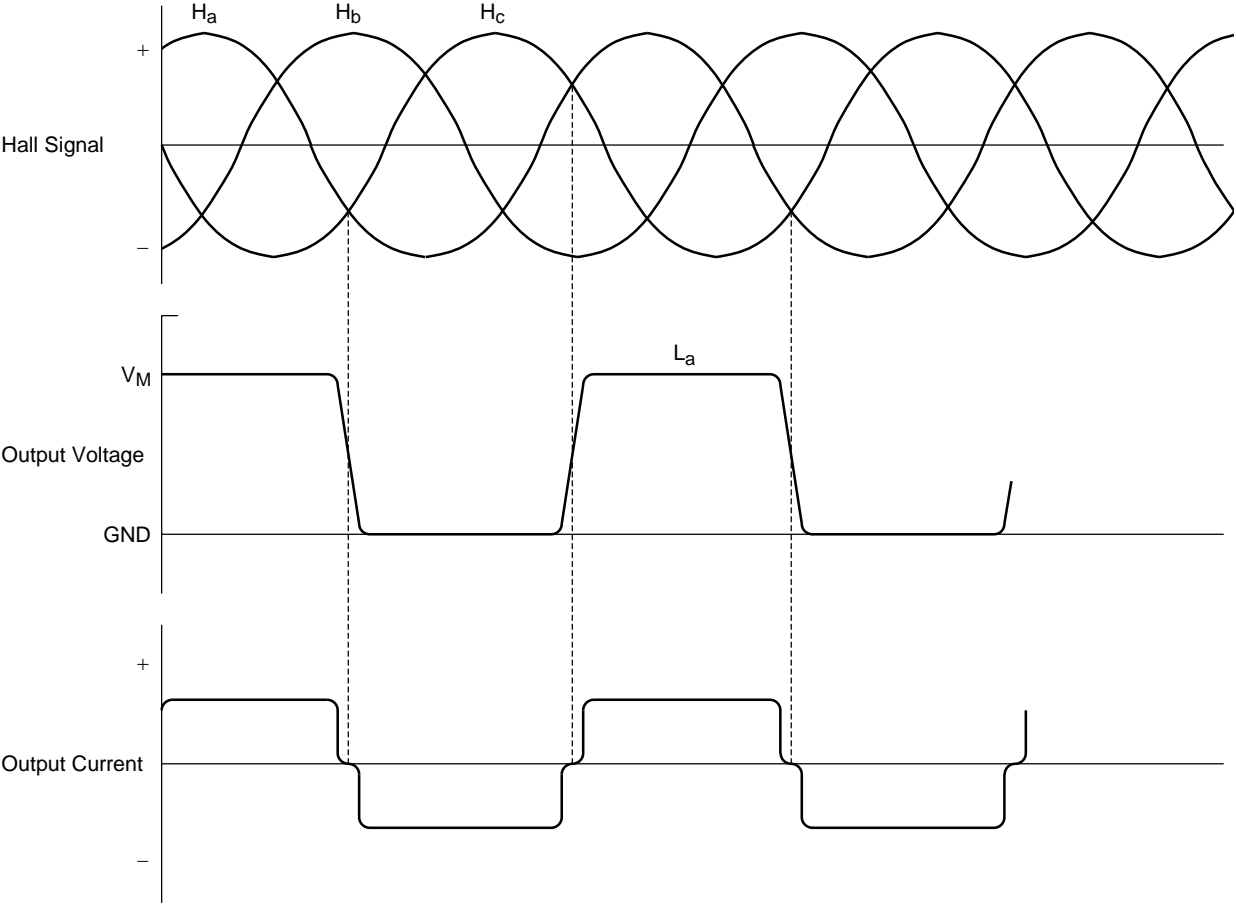

Functional Description

This IC is a 3-phase, full wave brushless DC motor driver of the direct PWM control type.

- Control amp input circuit

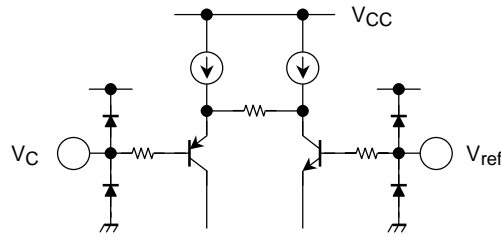

The common mode input voltage ranges for both V_C and V_{ref} are 0.5 to 4.0 V.

Relation between control input and PWM ON duty is shown below, PWM ON duty is 100% when $|V_{ref} - V_C| = 0.75$ V (typ.)

The input is provided with a dead-zone area whose voltage width is 100 mV (typ.)

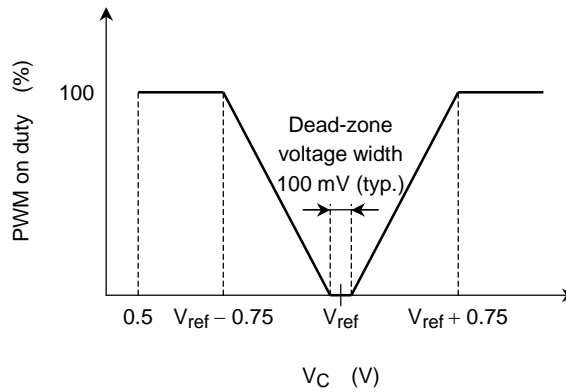

- Mode select/short brake circuit

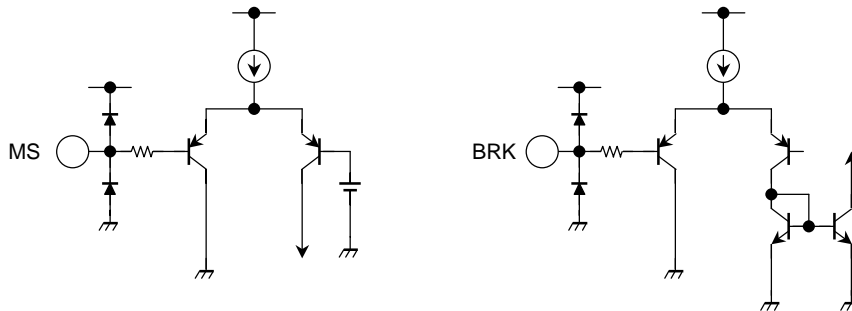

When $V_C > V_{ref}$, one of three modes (reverse rotation, reversing brake or short brake mode) can be selected by setting the MS and BRK pins appropriately.

<Function>

$V_C < V_{ref}$

		BRK	
		H	L
MS	H	Forward	Forward
	L	Forward	Forward

$V_C > V_{ref}$

		BRK	
		H	L
MS	H	Short brake	Reverse
	L	Short brake	Reversing brake

In Short Brake mode, the upper-stage power transistor is turned on and the lower-stage power transistor is turned off.

(short brake)

MS: H or L, BRK: H

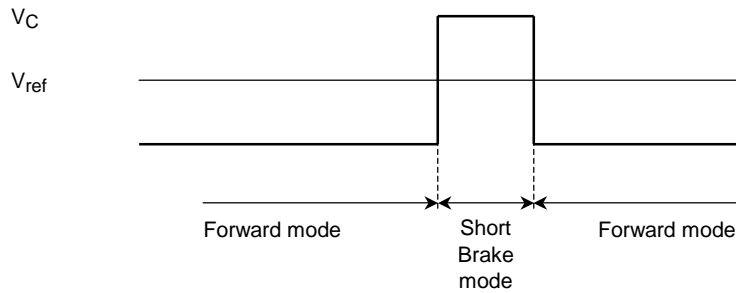

(reversing brake)

(1) When stopping the motor by applying a reversing brake after a short brake

MS: L

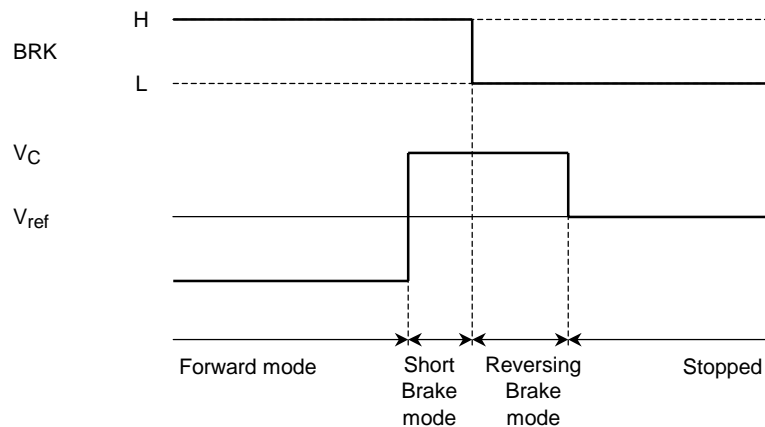

(2) When stopping the motor using reversing brake mode

MS: L, BRK: L

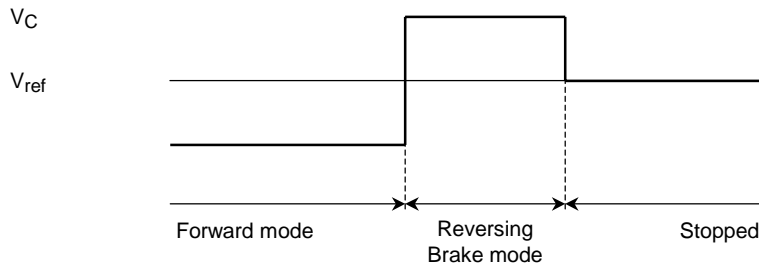

Note3: For an explanation of the Reversing Brake mode stopping sequence, refer to the explanation of the reverse rotation detection circuit.

The short brake generates less heat than the reversing brake. Therefore Toshiba recommends a combined use of the short and reversing brakes when stopping the motor.

- Run/stop control circuit

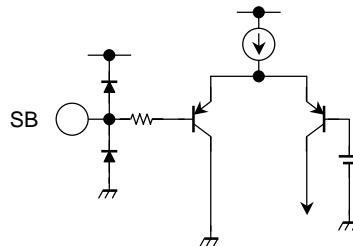

When the driver IC is standing by, all of its circuits except the FG amp and the hall amp are turned off.

H: start
L: standby

- Hall amp circuit

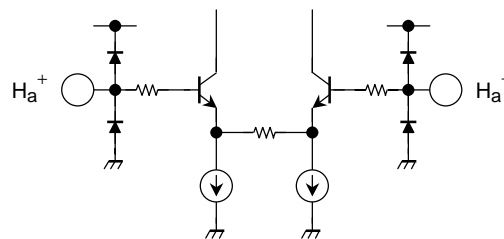

The common mode input voltage range for V_{CMRH} is 1.5 to 4.0 V.

- Hall element bias circuit

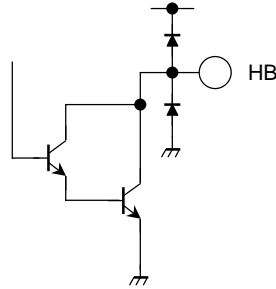

The hall element bias current is turned off when the driver IC is in standby state.

Make sure that the negative hall bias line is connected to the HB pin.

The remaining voltage is as follows:

$$V_{HB} = 1.2 \text{ V (typ.)} \quad \text{at } I_{HB} = 10 \text{ mA}$$

Furthermore, this circuit cannot be used if FG output is necessary in standby state.

When the HB terminal is not used, the negative hall bias line must be connected to GND with a resistor in between.

- FG amp circuit

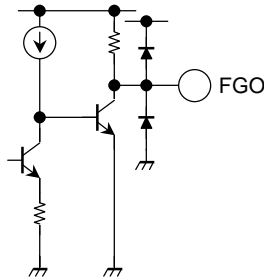

This circuit uses a hall element signal which is output to FGO after a Schmitt stage.

The FG amp has a hysteresis of 20 mV_{p-p} (typ.) and its output voltages are

$$\text{High level: } V_{CC} - 0.5 \text{ to } V_{CC} \text{ [V]}$$

$$\text{Low level: GND to } 0.5 \text{ V} \quad \text{at } I_{OFG} = 10 \text{ } \mu\text{A}$$

The FG amp is active when it is in standby state. When the hall element signal is input, the FG signal is output.

- Reverse rotation detection circuit

By comparing the two phases of the Hall element signal, this circuit detects a state where the phases are inverted, at which time the torque is reduced to 0. The detection accuracy is determined by the number of pulses per rotation of Hall element output.

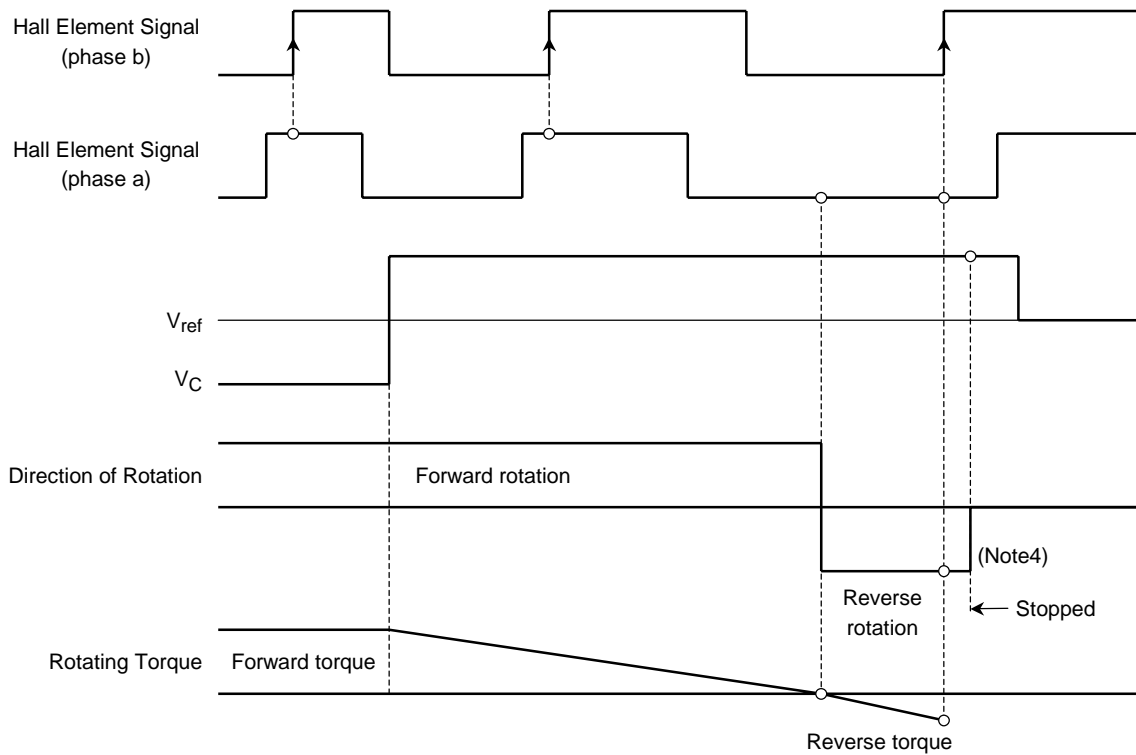

Note4: Due to its inertial force, the motor does not stop immediately after the torque is reduced to 0.

- Current limiter circuit

The current limit value is determined by the equation below.

$$I_{LIM} \approx \frac{0.3}{R_F + 0.1} \text{ [A] (typ.)}$$

This circuit cut off lower power transistors compulsorily when filtered V_{RF} is more than reference voltage. (0.3 V)

PWM signal cut off compulsorily is released from OFF state by next ON signal.

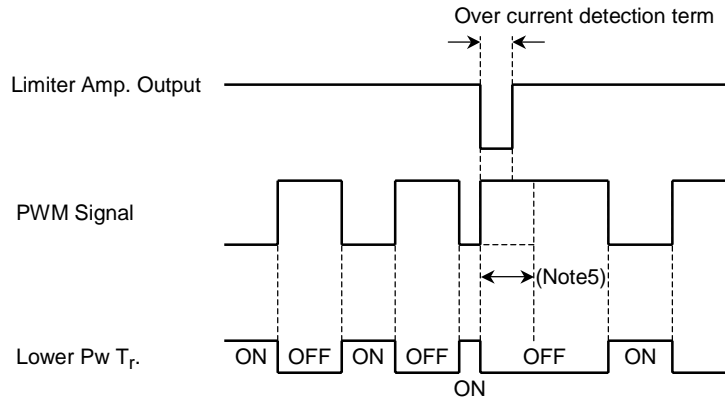

Note5: Keep "H" level in this term

Consider inside resistance (5 kΩ) when setting the capacitance value (C_{RF}).

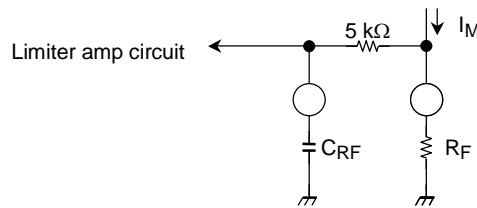

- Thermal shut down circuit

The circuit turns off output when T_j = 175°C (typ.) (according to design specification)

External Parts

Terminal No.	Function	Recommended Value	Remarks
C ₁	Power supply line oscillation prevention	0.22 μ F	—
C ₂	Power supply line noise prevention	100 pF to 1000 pF	(Note6)
C ₃	Power supply line noise prevention	10 μ F to 33 μ F	(Note6)
C ₄	Filter	470 pF	—
C ₅	Forward/reverse changeover gain adjustment	0.01 μ F	(Note7)
C ₆	Triangular wave oscillation	470 pF to 1000 pF	—
R ₁	Hall element bias	—	(Note8)
R ₂	Control amp reference voltage	—	(Note9)
R ₃	Output current detection	0.25 Ω to 0.5 Ω	—

Note6: Absorb switching noise by C₂ and C₃.

Note7: This is used to adjust the rotation direction changeover gain.

This capacitance value and the gain are in inverse.

This capacitance is to prevent from output through current.

Note8: Be sure to set this bias so that the hall element output amplitude and common mode input voltage fall within the ranges specified in the table of electrical characteristic.

Note9: The voltage must be set to fall within the common mode input voltage range of the control amp.

Test Circuit

1. ICC1, ICC2, VINS (H), VINS (L), IINS

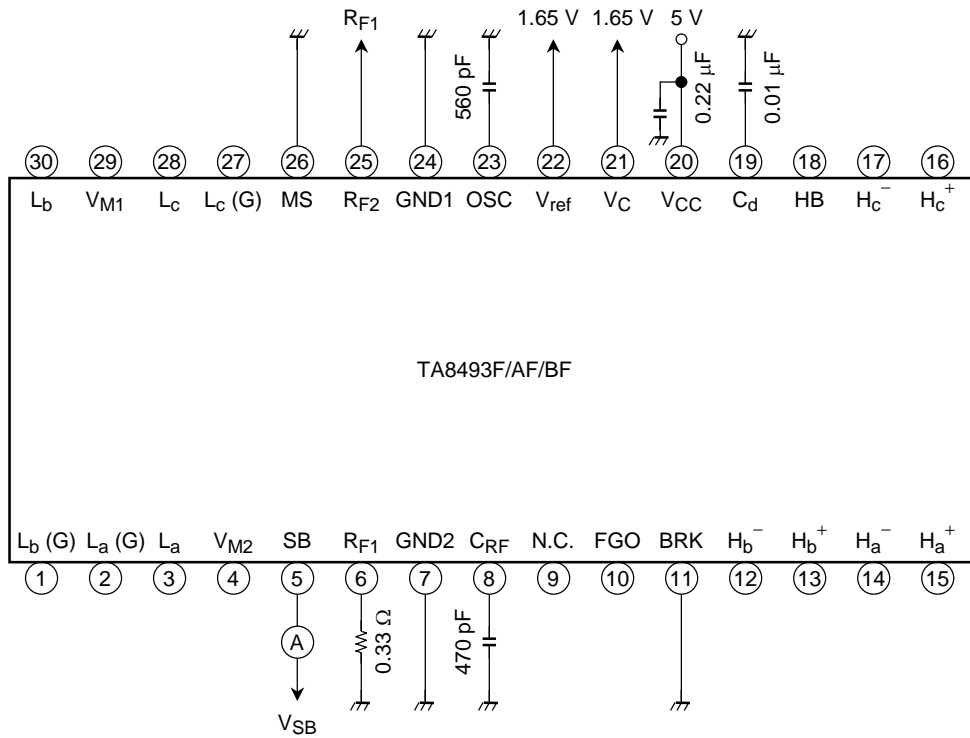

- ICC1: VSB = 0.5 V
- ICC2: VSB = 3.0 V
- VINS (H), VINS (L): Judged by the gap between ICC1 and ICC2
- IINS: VINS = 0 V

2. I_{INH} , I_{CMRH} , V_{HB} , I_{INC} , V_{CMRC}

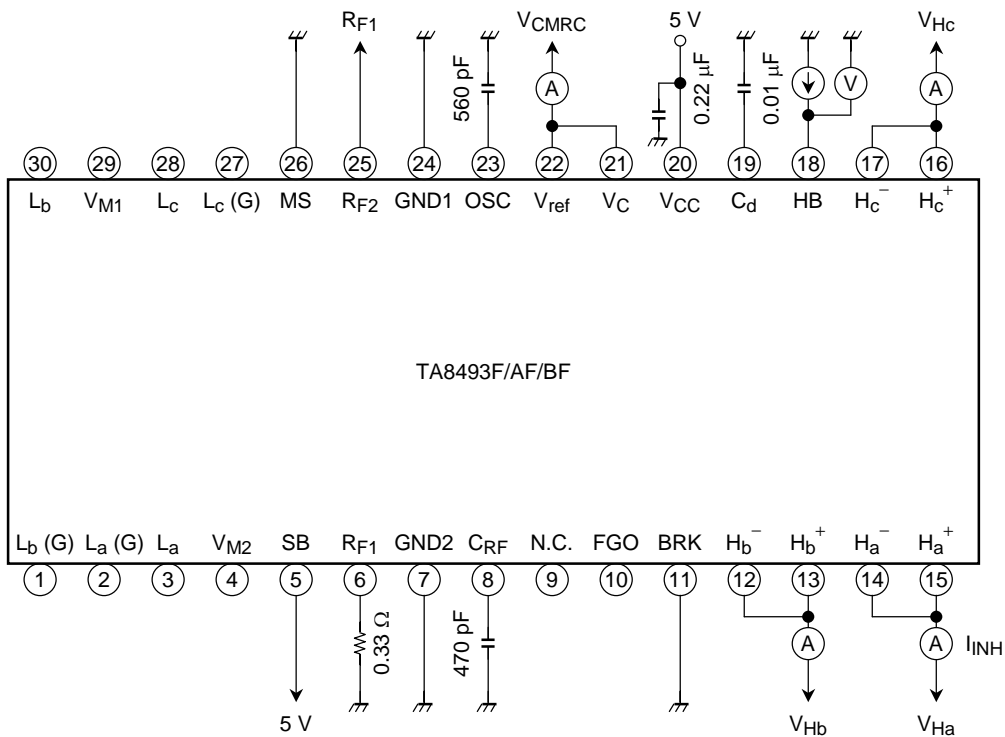

- I_{INH} : Total of a phase negative and positive input current.
 $V_{Ha} = V_{Hb} = V_{Hc} = 2.5\text{ V}$
- V_{CMRH} : Measure the I_{INH} gap between $V_{Ha} = 1.5\text{ V}$ and $V_{Ha} = 4.0\text{ V}$.
 b and c phase are measured the same method.
- V_{HB} : $I_{HB} = 10\text{ mA}$
- V_{INC} : Total of V_C and V_{ref} input current. At $V_{CMRC} = 1.65\text{ V}$.
- V_{CMRC} : Measure the I_{INC} gap between $V_{CMRC} = 0.5\text{ V}$ and $V_{CMRC} = 4.0\text{ V}$.

3. $\Delta V_{OFF} (F)$, $\Delta V_{OFF} (R)$, V_{LIM}

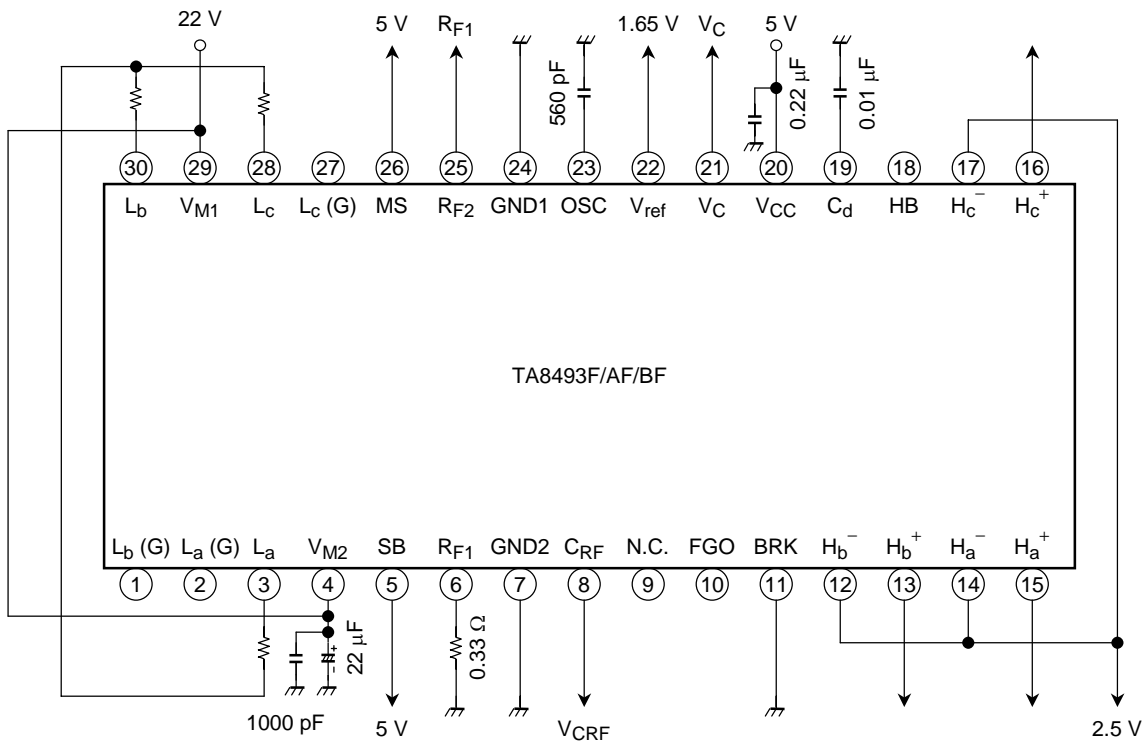

- $\Delta V_{OFF} (F)$: Measure V_{RF} at $V_C = 1.63 \text{ V}/1.5 \text{ V}$.
- $\Delta V_{OFF} (R)$: Measure V_{RF} at $V_C = 1.67 \text{ V}/1.8 \text{ V}$.
- V_{LIM} : Switch the V_{CRF} from 0 V to 0.4 V.

Measure the V_{CRF} at the point when output voltage level changes from low (L) to high (H)

4. RON (U), VSAT (L)

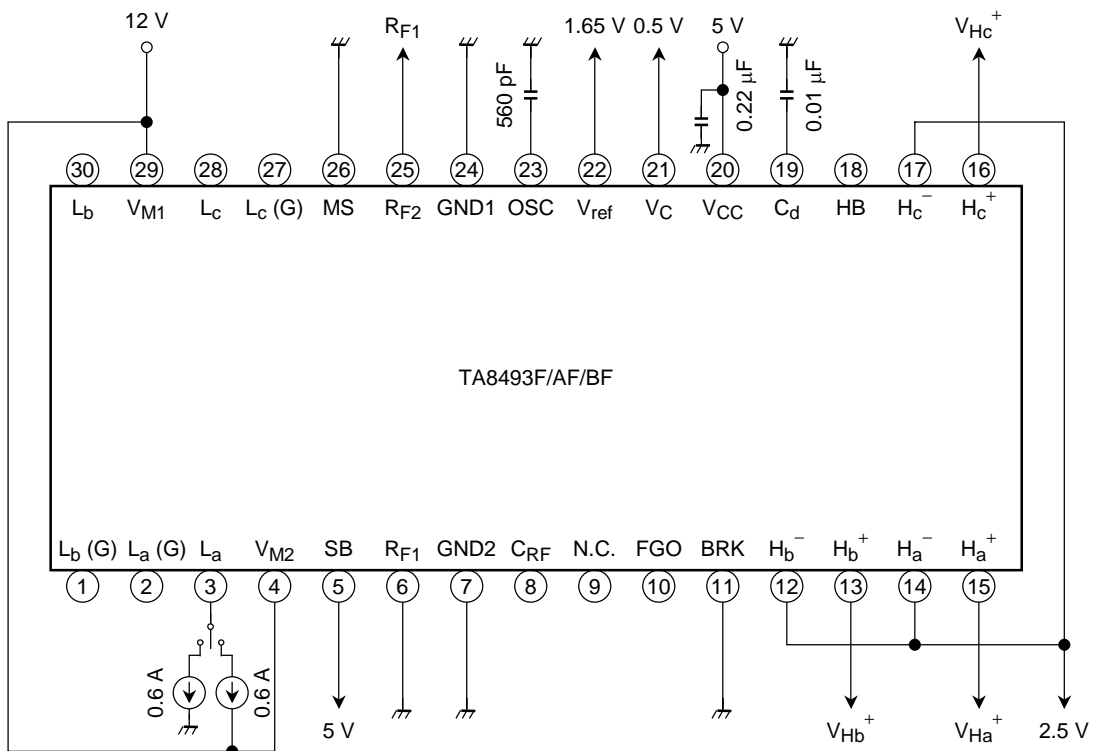

- RON (U): Determined output function by V_{Ha^+} , V_{Hb^+} , V_{Hc^+} (2.45 V/2.55 V).
Measure voltage value between V_M and L_a , and change to resistance valve. b phase and c phase are measured the same method.
- VSAT (L): Determined output function by V_{Ha^+} , V_{Hb^+} , V_{Hc^+} (2.45 V/2.55 V).
Measure voltage value between L_a and GND. b phase and c phase are measured the same method.

5. $I_L(U)$, $I_L(L)$

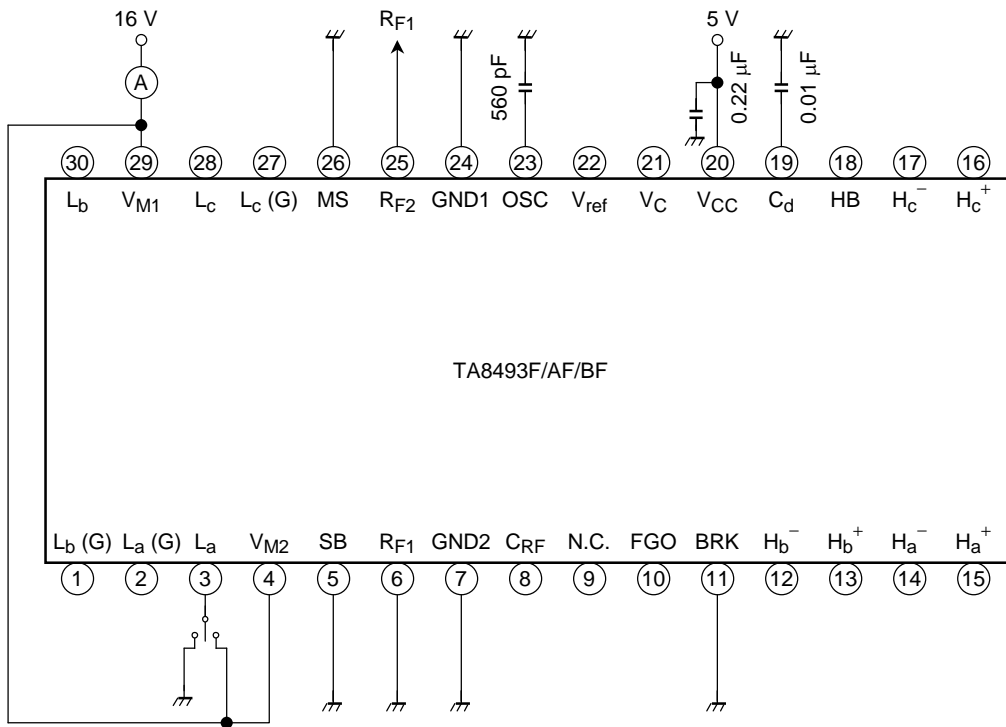

- $I_L(U)$: Measure I_M when L_a and GND are shorted. b phase and c phase are measured the same method.
- $I_L(L)$: Measure I_M when V_M and L_a are shorted. b phase and c phase are measured the same method.

6. V_{MS} (H), V_{MS} (L), I_{INS} , V_{BRK} (H), V_{BRK} (L), I_{INBRK}

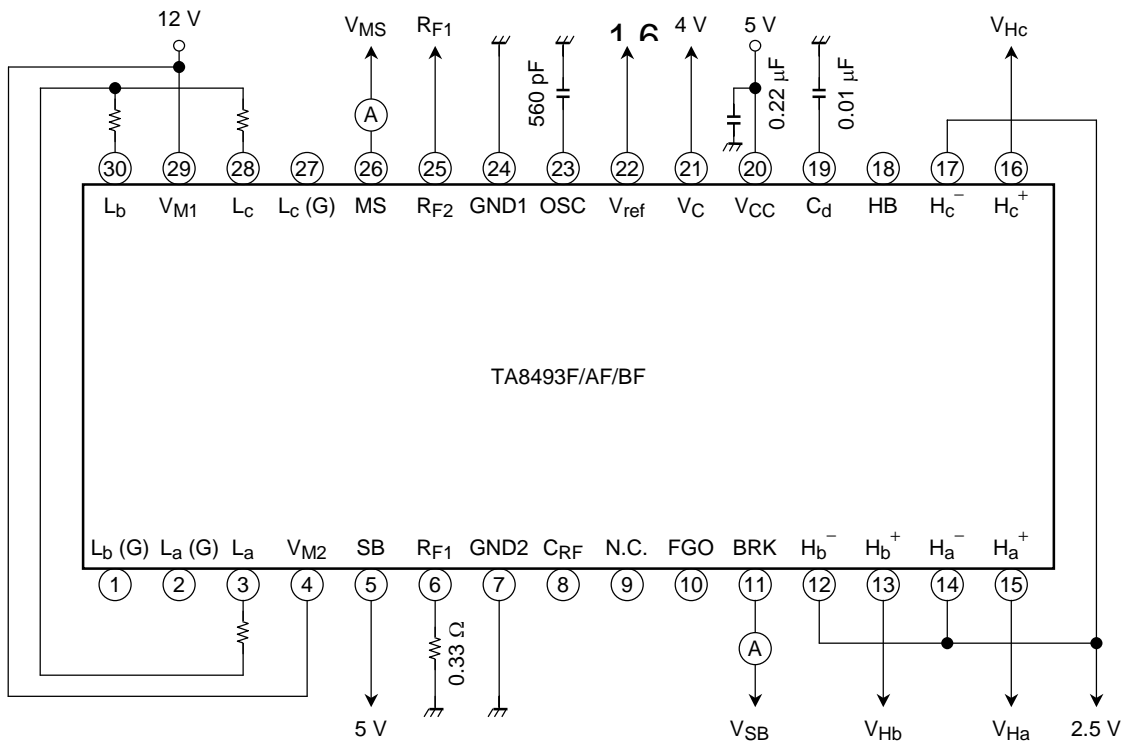

- V_{MS} (H): $V_{MS} = 3.0$ V, $V_{BRK} = 0$ V, verify that output function is reverse mode.
- V_{MS} (L): $V_{MS} = 0.5$ V, $V_{BRK} = 0$ V, switch from forward mode to reverse mode by V_{Ha} , V_{Hb} , V_{Hc} . Verify that V_{RF} changes to zero.
- I_{MS} (L): $V_{MS} = 0$ V, $V_{BRK} = 0$ V
- V_{BRK} (H): $V_{MS} = 5$ V, $V_{BRK} = 3.0$ V, verify that $L_a = L_b = L_c$: H
- V_{BRK} (L): $V_{MS} = 5$ V, $V_{BRK} = 0.5$ V, verify that output function is reverse mode.

7. $V_{OFG} (H), V_{OFG} (L)$

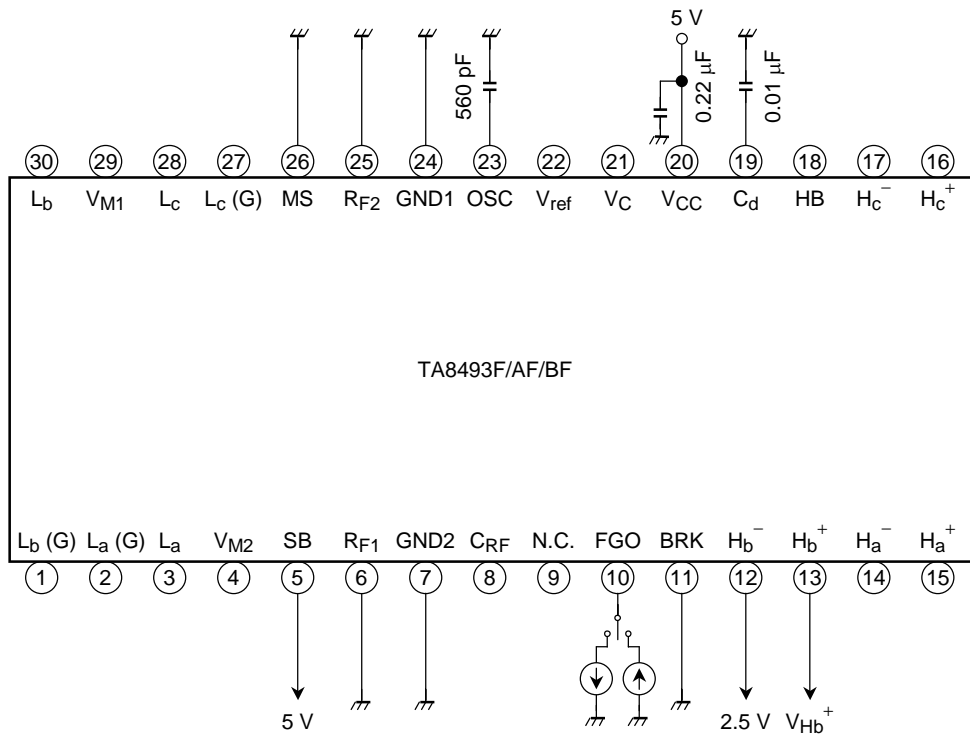

- $V_{OFG} (H)$: $V_{Hb^+} = 2.53 V$, $I_{FGO} = 10 \mu A$ (source)
- $V_{OFG} (L)$: $V_{Hb^+} = 2.47 V$, $I_{FGO} = 10 \mu A$ (sink)

8. V_{HYS}

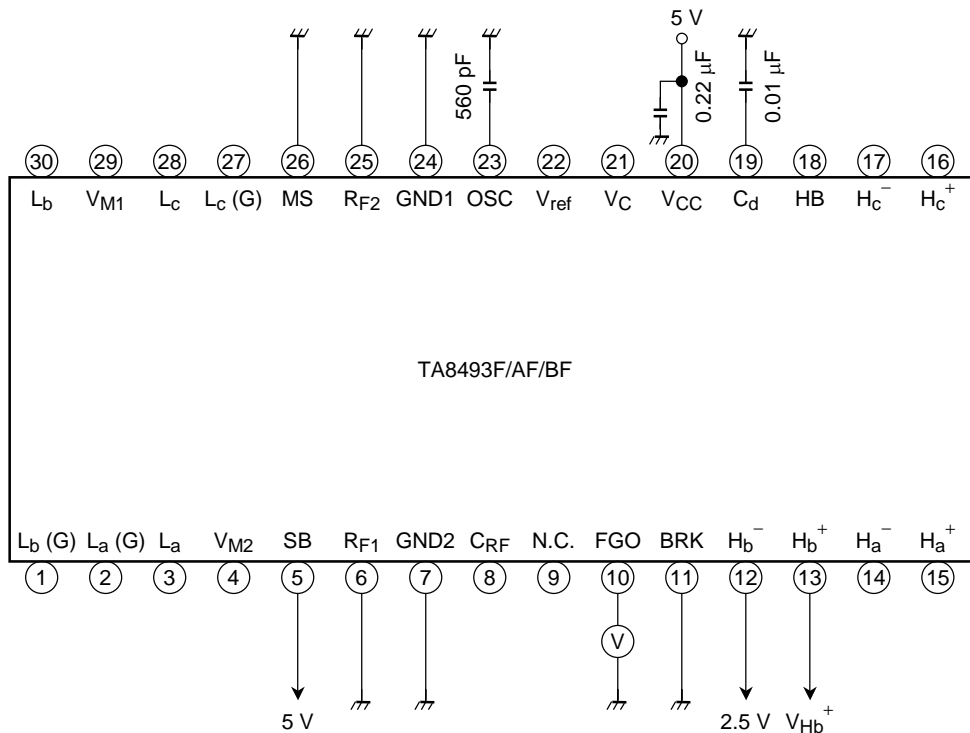

- V_{HYS} : Switch the V_{Hb^+} from high (H) to low (L) and from (L) to (H). Measure the V_{Hb^+} at the point when FGO function changes.

Application Circuit

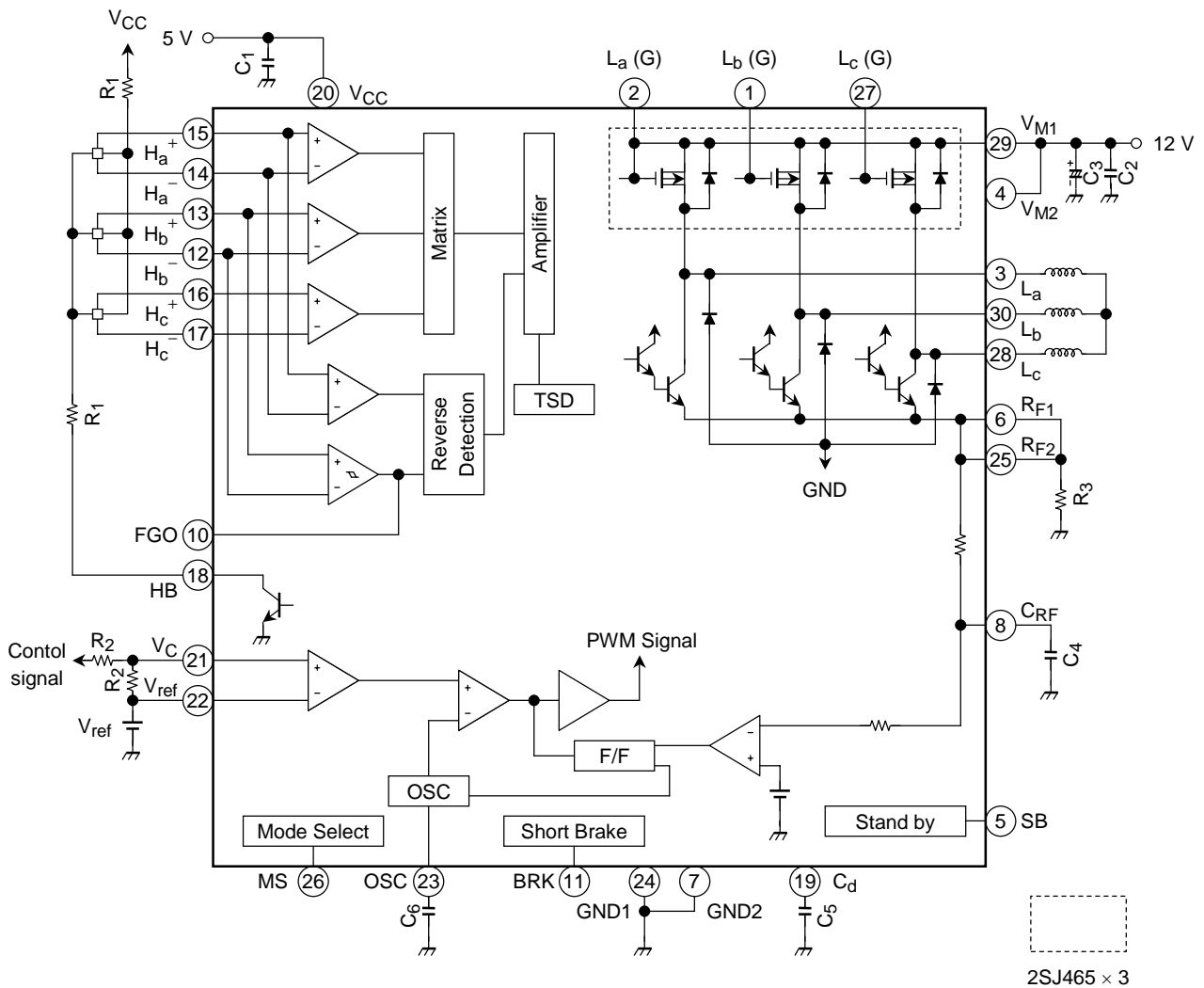

Note10: Utmost care is necessary in the design of the output line, V_{CC}, V_M and GND line since IC may be destroyed due to short-circuit between outputs, air contamination fault, or fault by improper grounding.

Package Dimensions

SSOP30-P-375-1.00

Unit : mm

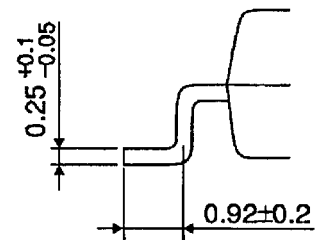
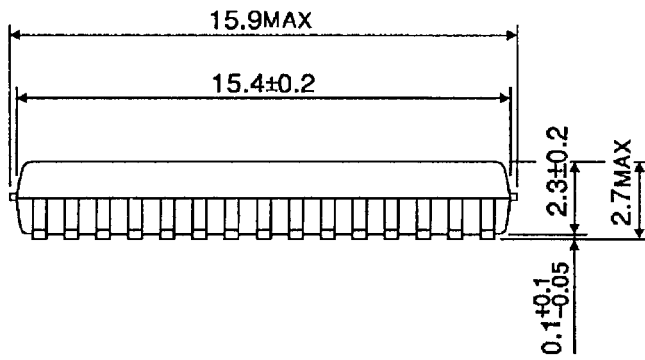
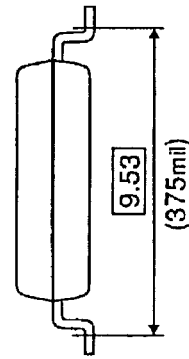
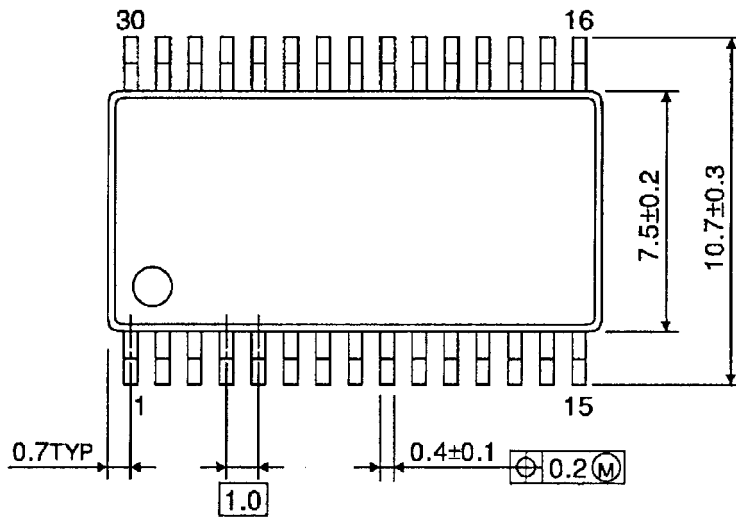

Weight: 0.63 g (typ.)

RESTRICTIONS ON PRODUCT USE

000707EBA

- TOSHIBA is continually working to improve the quality and reliability of its products. Nevertheless, semiconductor devices in general can malfunction or fail due to their inherent electrical sensitivity and vulnerability to physical stress. It is the responsibility of the buyer, when utilizing TOSHIBA products, to comply with the standards of safety in making a safe design for the entire system, and to avoid situations in which a malfunction or failure of such TOSHIBA products could cause loss of human life, bodily injury or damage to property.
In developing your designs, please ensure that TOSHIBA products are used within specified operating ranges as set forth in the most recent TOSHIBA products specifications. Also, please keep in mind the precautions and conditions set forth in the "Handling Guide for Semiconductor Devices," or "TOSHIBA Semiconductor Reliability Handbook" etc..
- The TOSHIBA products listed in this document are intended for usage in general electronics applications (computer, personal equipment, office equipment, measuring equipment, industrial robotics, domestic appliances, etc.). These TOSHIBA products are neither intended nor warranted for usage in equipment that requires extraordinarily high quality and/or reliability or a malfunction or failure of which may cause loss of human life or bodily injury ("Unintended Usage"). Unintended Usage include atomic energy control instruments, airplane or spaceship instruments, transportation instruments, traffic signal instruments, combustion control instruments, medical instruments, all types of safety devices, etc.. Unintended Usage of TOSHIBA products listed in this document shall be made at the customer's own risk.
- The products described in this document are subject to the foreign exchange and foreign trade laws.
- The information contained herein is presented only as a guide for the applications of our products. No responsibility is assumed by TOSHIBA CORPORATION for any infringements of intellectual property or other rights of the third parties which may result from its use. No license is granted by implication or otherwise under any intellectual property or other rights of TOSHIBA CORPORATION or others.
- The information contained herein is subject to change without notice.