

VIDEO COLOR SUPERIMPOSER

■ GENERAL DESCRIPTION

NJM2247 A/B is the multi-functional color superimposer IC for video base band (Y, R-Y, B-Y). Various type of Y, R-Y, B-Y output signals can be made by the digital controlled signals. The signal control at the base band, made it possible on operation with less external parts, as well as for non adjustment on operation.

■ FEATURES

- 5V Single Power Supply
- 8 Types Color Superimposer
- Burst Flag Insert Function
- Y Inversion, C Inversion Function
- NTSC/PAL Matching
- Non Operational Adjustment
- Less External Parts
- Package Outline DMP20
- Bipolar Technology

■ RECOMMENDED INPUT CONDITIONS

- Y Signal 0.7 V_{P-P}
- R-Y Signal 1.0 V_{P-P}
- B-Y Signal 0.7 V_{P-P}
- Control Voltage
- Low Level 0~0.25 V
- High Level 4.75~5 V

■ PIN CONFIGURATION

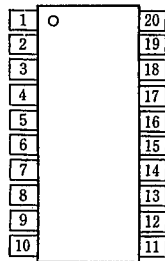

NJM2247 AM/BM

■ PACKAGE OUTLINE

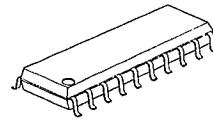

NJM2247 AM/BM

PIN FUNCTION

- | | |
|-----------------------|---------------------------------|
| 1. Y _{out} | 11. GND |
| 2. V ⁺ | 12. HBF Pulse |
| 3. R | 13. BF |
| 4. G | 14. NTSC/PAL Switching |
| 5. B | 15. Clamp Pulse |
| 6. B-Y _{in} | 16. Character Pulse |
| 7. B-Y _{out} | 17. Y _{in} |
| 8. R-Y _{in} | 18. Inversion Set up Correction |
| 9. R-Y _{out} | 19. Y Inversion |
| 10. C Inversion | 20. BLK Pulse |

■ BLOCK DIAGRAM

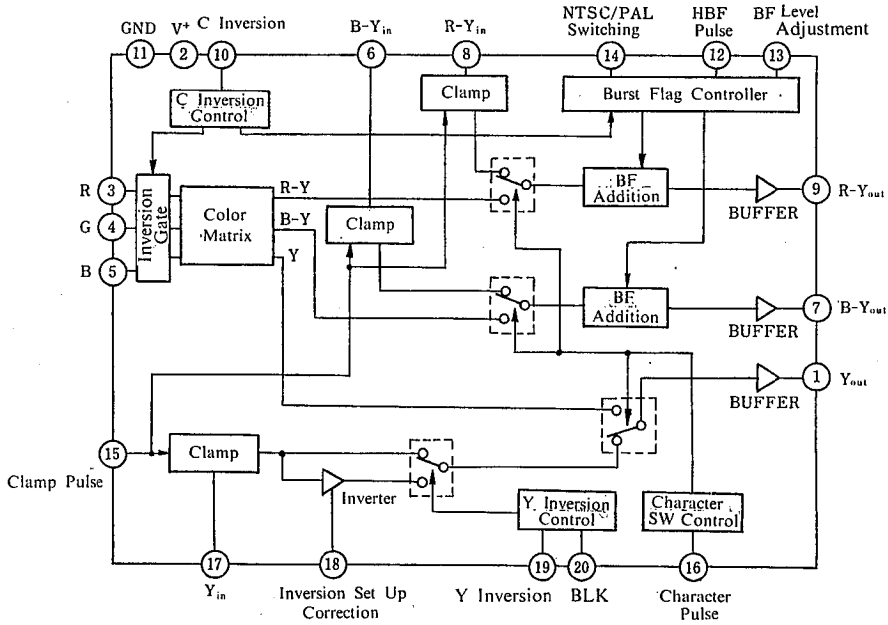

■ CONTROL PIN CHARACTERISTICS

(V⁺=5V)

PIN NO.	PIN FUNCTIONS	THRESHOLD LEVEL(V)		SINK/SOURCE CURRENT(μA)	
		LOW	HIGH	0V	5V
3	R				
4	G				
5	B				
3					
4	(at C Inversion)	0.7	0.8	-500	500
5					
10	C Inversion	2.5	2.6	-100	100
12	HBF Pulse	3.5	4.5	-200	400
14	NTSC/PAL	0.5	2.0	-2	1
15	Clamp Pulse	0.7	0.8	0	150
16	Character Pulse	2.5	2.8	-2	0
19	Y Inversion	0.5	0.9	-0.5	0
20	BLK Pulse	0.4	0.8	-0.5	0
		0.4	0.8	-0.5	0

■ TEST CIRCUIT

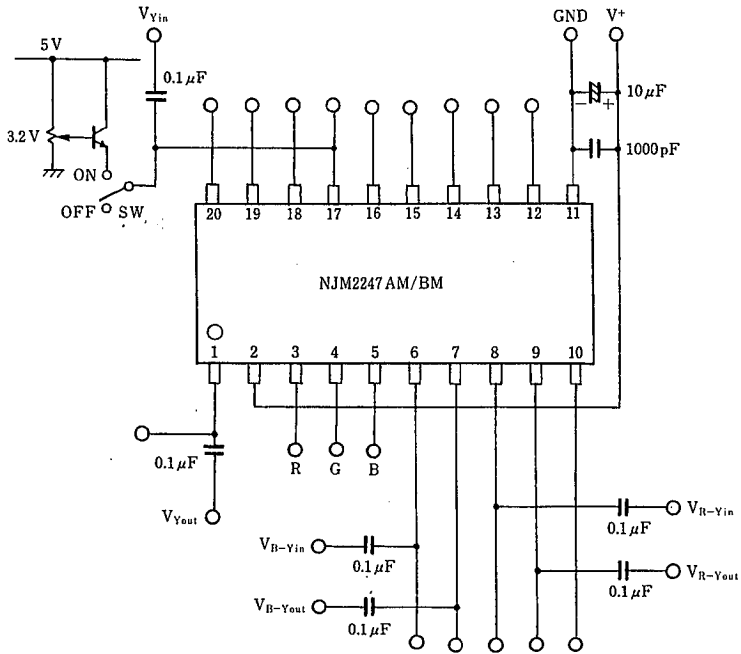

■ ABSOLUTE MAXIMUM RATINGS

(T_a=25°C)

PARAMETER	SYMBOL	RATINGS	UNIT
Supply Voltage	V*	8	V
Power Dissipation	P _D	300	mW
Operating Temperature Range	T _{opr}	-20~+75	°C
Storage Temperature Range	T _{stg}	-40~+125	°C

■ ELECTRICAL CHARACTERISTICS

(V*=5V, T_a= 25°C)

PARAMETERS	SYMBOLS	CONTROL PINS								TEST CONDITIONS	MIN.	TYP.	MAX.	UNIT
		③	④	⑤	⑩	⑫	⑬	⑮	⑰					
Operating Current	I _{CC}	0	0	0	0	0	0	0	0	NJM2247A NJM2247B	12	16.5	22	mA
Terminal Sink Current 1	I ₁₇	0	0	0	0	0	0	0	0	V ₁₇ =2.5 V	0	-	10	μA
Terminal Sink Current 2	I ₆	0	0	0	0	0	0	0	0	V ₆ =3.0 V	0	-	6	μA
Terminal Sink Current 3	I ₈	0	0	0	0	0	0	0	0	V ₈ =3.0 V	0	-	6	μA
Terminal Voltage 1	V ₁	0	0	0	0	0	5	0	0		1.68	-	1.92	V
Terminal Voltage 2	V ₇	0	0	0	0	0	5	0	0		2.18	-	2.42	V
Terminal Voltage 3	V ₉	0	0	0	0	0	5	0	0		2.18	-	2.42	V
Terminal Voltage 4	V ₁₃	0	0	0	0	0	5	0	0		0.23	-	0.37	V
Terminal Voltage 5	V ₁₈	0	0	0	0	0	5	0	0		1.68	-	1.92	V
Y Non Inversion														
Voltage Gain	G _{YP}	0	0	0	0	0	0	0	0	V _(Yin) =1 V _{P-P} , 1 MHz, SW=ON	-0.5	0	0.5	dB
Frequency Characteristics	G _{FYP}	0	0	0	0	0	0	0	0	G _{Y(6 MHz)} -G _{Y(1 MHz)} , SW=ON	-1	0	1	dB
Differential Gain	DG _P	0	0	0	0	0	0	0	0	V _(Yin) =1 V _{P-P} , Staircase, SW=ON	-3	0	3	%
Differential Phase	DP _P	0	0	0	0	0	0	0	0	V _(Yin) =1 V _{P-P} , Staircase, SW=ON	-3	0	3	deg
Y Inversion														
Voltage Gain	G _{YN}	0	0	0	0	0	0	5	5	V _(Yin) =0.6 V _{P-P} , 1 MHz, SW=ON	-2.3	-1.3	0.3	dB
Frequency Characteristics	G _{FYN}	0	0	0	0	0	0	5	5	G _{Y(6 MHz)} -G _{Y(1 MHz)} , SW=ON	-2	-0.1	1	dB
Differential Gain	DG _N	0	0	0	0	0	0	5	5	V _(Yin) =0.5 V _{P-P} , Staircase, SW=ON	-8	-	8	%
Differential Phase	DP _N	0	0	0	0	0	0	5	5	V _(Yin) =0.5 V _{P-P} , Staircase, SW=ON	-3	0	3	deg
Inversion Black Level	BL _N	0	0	0	0	0	5	0	5	① Voltage; a, BL _N =a-b	0.59	0.68	0.77	V
Inversion BLK	BL _K	0	0	0	0	0	5	0	5	① Voltage; b, BL _N =a-b				
R-Y														
Voltage Gain	G _{R-Y}	0	0	0	0	0	5	0	0	V _(R-Yin) =1 V _{P-P} , 1 MHz	-0.5	0	0.5	dB
Burst Level Non Inversion	BF _{RP}	0	0	0	0	0	5	0	0	② Voltage; d, BF _{RP} =e-d	135	150	165	mV
Burst Level Inversion	BF _{RN}	0	0	0	5	0	5	0	0	② Voltage; e, BF _{RP} =e-d				
B-Y														
Voltage Gain	G _{B-Y}	0	0	0	0	0	5	0	0	V _(B-Yin) =1 V _{P-P} , 1 MHz	-0.5	0	0.5	dB
Burst Level Non Inversion	BF _{BP}	0	0	0	0	5	5	0	0	② Voltage; g, BF _{BP} =g-h	135	150	165	mV
Burst Level Inversion	BF _{BN}	0	0	0	5	5	5	0	0	② Voltage; h, BF _{BP} =g-h				
		0	0	5	5	5	5	0	0	② Voltage; i, BF _{BN} =g-i	-165	-150	-135	mV

■ NJM2247A ELECTRICAL CHARACTERISTICS (CONTINUED)

(V⁺=5V, T_a=25°C)

PARAMETERS	SYMBOLS	CONTROL PINS								TEST CONDITIONS	MIN.	TYP.	MAX.	UNITS		
		③	④	⑤	⑩	⑫	⑬	⑮	⑱							
Character Output Level 1																
C Non Inversion																
White	Y	MPWY	5	5	5	0	0	0	5	5	0	① Voltage; A, MPWY=A-V ₁	482	530	583	mV
	R-Y	MPWR	5	5	5	0	0	0	5	5	0	⑨ Voltage; B, MPWR=B-V ₉	-14	0	14	mV
	B-Y	MPWB	5	5	5	0	0	0	5	5	0	⑦ Voltage; C, MPWB=C-V ₇	-12	0	12	mV
Yellow	Y	MPYY	5	5	0	0	0	0	5	5	0	① Voltage; A, MPYY=A-V ₁	427	470	517	mV
	R-Y	MPYR	5	5	0	0	0	0	5	5	0	⑨ Voltage; B, MPYR=B-V ₉	22	42	62	mV
	B-Y	MPYB	5	5	0	0	0	0	5	5	0	⑦ Voltage; C, MPYB=C-V ₇	-206	-186	-166	mV
Cyan	Y	MPCY	0	5	5	0	0	0	5	5	0	① Voltage; A, MPCY=A-V ₁	335	370	410	mV
	R-Y	MPCR	0	5	5	0	0	0	5	5	0	⑨ Voltage; B, MPCR=B-V ₉	-289	-266	-243	mV
	B-Y	MPCB	0	5	5	0	0	0	5	5	0	⑦ Voltage; C, MPCB=C-V ₇	40	63	87	mV
Green	Y	MPGY	0	5	0	0	0	0	5	5	0	① Voltage; A, MPGY=A-V ₁	285	313	334	mV
	R-Y	MPCR	0	5	0	0	0	0	5	5	0	⑨ Voltage; B, MPCR=B-V ₉	-243	-224	-205	mV
	B-Y	MPCB	0	5	0	0	0	0	5	5	0	⑦ Voltage; C, MPCB=C-V ₇	-145	-123	-105	mV
Magenta	Y	MPMY	5	0	5	0	0	0	5	5	0	① Voltage; A, MPMY=A-V ₁	198	218	240	mV
	R-Y	MPMR	5	0	5	0	0	0	5	5	0	⑨ Voltage; B, MPMR=B-V ₉	205	224	243	mV
	B-Y	MPMB	5	0	5	0	0	0	5	5	0	⑦ Voltage; C, MPMB=C-V ₇	105	123	145	mV
Red	Y	MPLY	5	0	0	0	0	0	5	5	0	① Voltage; A, MPLY=A-V ₁	145	160	176	mV
	R-Y	MPLR	5	0	0	0	0	0	5	5	0	⑨ Voltage; B, MPLR=B-V ₉	243	266	289	mV
	B-Y	MPLB	5	0	0	0	0	0	5	5	0	⑦ Voltage; C, MPLB=C-V ₇	-87	-63	-40	mV
Blue	Y	MPBY	0	0	5	0	0	0	5	5	0	① Voltage; A, MPBY=A-V ₁	40	58	76	mV
	R-Y	MPBR	0	0	5	0	0	0	5	5	0	⑨ Voltage; B, MPBR=B-V ₉	-62	-42	-22	mV
	B-Y	MPBB	0	0	5	0	0	0	5	5	0	⑦ Voltage; C, MPBB=C-V ₇	166	186	206	mV
Black	Y	MPPY	0	0	0	0	0	0	5	5	0	① Voltage; A, MPPY=A-V ₁	-20	0	20	mV
	R-Y	MPPR	0	0	0	0	0	0	5	5	0	⑨ Voltage; B, MPPR=B-V ₉	-14	0	14	mV
	B-Y	MPPB	0	0	0	0	0	0	5	5	0	⑦ Voltage; C, MPPB=C-V ₇	-12	0	12	mV
Character Output Level 2																
C Inversion																
White	Y	MNWy	5	5	5	0	0	5	5	0	① Voltage; A, MNWy=A-V ₁	482	530	583	mV	
	R-Y	MNWR	5	5	5	0	0	5	5	0	⑨ Voltage; B, MNWR=B-V ₉	-14	0	14	mV	
	B-Y	MNWB	5	5	5	0	0	5	5	0	⑦ Voltage; C, MNWB=C-V ₇	-12	0	12	mV	
Yellow	Y	MNYy	5	5	0	5	0	0	5	5	0	① Voltage; A, MNYy=A-V ₁	427	470	517	mV
	R-Y	MNYR	5	5	0	5	0	0	5	5	0	⑨ Voltage; B, MNYR=B-V ₉	-62	-42	-22	mV
	B-Y	MNYB	5	5	0	5	0	0	5	5	0	⑦ Voltage; C, MNYB=C-V ₇	166	186	206	mV
Cyan	Y	MNCy	0	5	5	0	0	5	5	0	① Voltage; A, MNCy=A-V ₁	335	370	410	mV	
	R-Y	MNCR	0	5	5	0	0	5	5	0	⑨ Voltage; B, MNCR=B-V ₉	243	266	289	mV	
	B-Y	MNCB	0	5	5	0	0	5	5	0	⑦ Voltage; C, MNCB=C-V ₇	-87	-63	-40	mV	
Green	Y	MNGy	0	5	0	5	0	0	5	5	0	① Voltage; A, MNGy=A-V ₁	285	313	334	mV
	R-Y	MNGR	0	5	0	5	0	0	5	5	0	⑨ Voltage; B, MNGR=B-V ₉	205	224	243	mV
	B-Y	MNCB	0	5	0	5	0	0	5	5	0	⑦ Voltage; C, MNCB=C-V ₇	105	123	145	mV
Magenta	Y	MNMy	5	0	5	5	0	0	5	5	0	① Voltage; A, MNMy=A-V ₁	198	218	240	mV
	R-Y	MNMR	5	0	5	5	0	0	5	5	0	⑨ Voltage; B, MNMR=B-V ₉	-243	-224	-205	mV
	B-Y	MNMB	5	0	5	5	0	0	5	5	0	⑦ Voltage; C, MNMB=C-V ₇	-145	-123	-105	mV
Red	Y	MNRy	5	0	0	5	0	0	5	5	0	① Voltage; A, MNRy=A-V ₁	145	160	176	mV
	R-Y	MNRR	5	0	0	5	0	0	5	5	0	⑨ Voltage; B, MNRR=B-V ₉	-289	-266	-243	mV
	B-Y	MNRB	5	0	0	5	0	0	5	5	0	⑦ Voltage; C, MNRB=C-V ₇	40	63	87	mV
Blue	Y	MNBy	0	0	5	5	0	0	5	5	0	① Voltage; A, MNBy=A-V ₁	40	58	76	mV
	R-Y	MNBR	0	0	5	5	0	0	5	5	0	⑨ Voltage; B, MNBR=B-V ₉	22	42	62	mV
	B-Y	MNBB	0	0	5	5	0	0	5	5	0	⑦ Voltage; C, MNBB=C-V ₇	-206	-186	-166	mV
Black	Y	MNPY	0	0	0	5	0	0	5	5	0	① Voltage; A, MNPY=A-V ₁	-20	0	20	mV
	R-Y	MNPR	0	0	0	5	0	0	5	5	0	⑨ Voltage; B, MNPR=B-V ₉	-14	0	14	mV
	B-Y	MNPB	0	0	0	5	0	0	5	5	0	⑦ Voltage; C, MNPB=C-V ₇	-12	0	12	mV

5

■ NJM2247B ELECTRICAL CHARACTERISTICS (CONTINUED)

(V^{*}=5V, T_a=25°)

PARAMETERS	SYMBOLS	CONTROL PINS										TEST CONDITIONS	MIN.	TYP.	MAX.	UNITS	
		③	④	⑤	⑩	⑫	⑬	⑭	⑮	⑯	⑰						
Character Output Level 1																	
C Non Inversion																	
White	Y	MPWY	5	5	5	0	0	0	5	5	0	0	① Voltage; A, MPWY=A-V ₁	630	700	770	mV
	R-Y	MPWR	5	5	5	0	0	0	5	5	0	0	⑨ Voltage; B, MPWR=B-V ₉	-14	0	14	mV
	B-Y	MPWB	5	5	5	0	0	0	5	5	0	0	⑦ Voltage; C, MPWB=C-V ₇	-12	0	12	mV
Yellow	Y	MPYY	5	5	0	0	0	0	5	5	0	0	① Voltage; A, MPYY=A-V ₁	472	525	578	mV
	R-Y	MPYR	5	5	0	0	0	0	5	5	0	0	⑨ Voltage; B, MPYR=B-V ₉	13	33	53	mV
	B-Y	MPYB	5	5	0	0	0	0	5	5	0	0	⑦ Voltage; C, MPYB=C-V ₇	-165	-146	-127	mV
Cyan	Y	MPCY	0	5	5	0	0	0	5	5	0	0	① Voltage; A, MPCY=A-V ₁	409	455	501	mV
	R-Y	MPCR	0	5	5	0	0	0	5	5	0	0	⑨ Voltage; B, MPCR=B-V ₉	-232	-209	-186	mV
	B-Y	MPCB	0	5	5	0	0	0	5	5	0	0	⑦ Voltage; C, MPCB=C-V ₇	28	50	72	mV
Green	Y	MPCY	0	5	0	0	0	0	5	5	0	0	① Voltage; A, MPGY=A-V ₁	252	280	308	mV
	R-Y	MPCR	0	5	0	0	0	0	5	5	0	0	⑨ Voltage; B, MPCR=B-V ₉	-197	-176	-155	mV
	B-Y	MPCB	0	5	0	0	0	0	5	5	0	0	⑦ Voltage; C, MPGB=C-V ₇	-117	-97	-77	mV
Magenta	Y	MPMY	5	0	5	0	0	0	5	5	0	0	① Voltage; A, MPMY=A-V ₁	378	420	462	mV
	R-Y	MPMR	5	0	5	0	0	0	5	5	0	0	⑨ Voltage; B, MPMR=B-V ₉	155	176	197	mV
	B-Y	MPMB	5	0	5	0	0	0	5	5	0	0	⑦ Voltage; C, MPMB=C-V ₇	77	97	117	mV
Red	Y	MPRY	5	0	0	0	0	0	5	5	0	0	① Voltage; A, MPRY=A-V ₁	220	245	270	mV
	R-Y	MPRR	5	0	0	0	0	0	5	5	0	0	⑨ Voltage; B, MPRR=B-V ₉	186	209	232	mV
	B-Y	MPRB	5	0	0	0	0	0	5	5	0	0	⑦ Voltage; C, MPRB=C-V ₇	-72	-50	-28	mV
Blue	Y	MPBY	0	0	5	0	0	0	5	5	0	0	① Voltage; A, MPBY=A-V ₁	156	175	194	mV
	R-Y	MPBR	0	0	5	0	0	0	5	5	0	0	⑨ Voltage; B, MPBR=B-V ₉	-53	-33	-13	mV
	B-Y	MPBB	0	0	5	0	0	0	5	5	0	0	⑦ Voltage; C, MPBB=C-V ₇	127	146	165	mV
Black	Y	MPPY	0	0	0	0	0	0	5	5	0	0	① Voltage; A, MPPY=A-V ₁	-20	0	20	mV
	R-Y	MPPR	0	0	0	0	0	0	5	5	0	0	⑨ Voltage; B, MPPR=B-V ₉	-14	0	14	mV
	B-Y	MPPB	0	0	0	0	0	0	5	5	0	0	⑦ Voltage; C, MPPB=C-V ₇	-12	0	12	mV
Character Output Level 2																	
C Inversion																	
White	Y	MNWy	5	5	5	0	0	5	5	0	0	① Voltage; A, MNWy=A-V ₁	630	700	770	mV	
	R-Y	MNWR	5	5	5	0	0	5	5	0	0	⑨ Voltage; B, MNWR=B-V ₉	-14	0	14	mV	
	B-Y	MNWB	5	5	5	0	0	5	5	0	0	⑦ Voltage; C, MNWB=C-V ₇	-12	0	12	mV	
Yellow	Y	MNYy	5	5	0	5	0	0	5	5	0	0	① Voltage; A, MNYy=A-V ₁	472	525	578	mV
	R-Y	MNYR	5	5	0	5	0	0	5	5	0	0	⑨ Voltage; B, MNYR=B-V ₉	-53	-33	-13	mV
	B-Y	MNYB	5	5	0	5	0	0	5	5	0	0	⑦ Voltage; C, MNYB=C-V ₇	127	146	165	mV
Cyan	Y	MNCy	0	5	5	5	0	0	5	5	0	0	① Voltage; A, MNCy=A-V ₁	409	455	501	mV
	R-Y	MNCR	0	5	5	5	0	0	5	5	0	0	⑨ Voltage; B, MNCR=B-V ₉	186	209	232	mV
	B-Y	MNCB	0	5	5	5	0	0	5	5	0	0	⑦ Voltage; C, MNCB=C-V ₇	-72	-50	-28	mV
Green	Y	MNGy	0	5	0	5	0	0	5	5	0	0	① Voltage; A, MNGy=A-V ₁	252	280	308	mV
	R-Y	MNGR	0	5	0	5	0	0	5	5	0	0	⑨ Voltage; B, MNGR=B-V ₉	155	176	197	mV
	B-Y	MNCB	0	5	0	5	0	0	5	5	0	0	⑦ Voltage; C, MNCB=C-V ₇	77	97	117	mV
Magenta	Y	MNMy	5	0	5	5	0	0	5	5	0	0	① Voltage; A, MNMy=A-V ₁	378	420	462	mV
	R-Y	MNMR	5	0	5	5	0	0	5	5	0	0	⑨ Voltage; B, MNMR=B-V ₉	-197	-176	-155	mV
	B-Y	MNMB	5	0	5	5	0	0	5	5	0	0	⑦ Voltage; C, MNMB=C-V ₇	-117	-97	-77	mV
Red	Y	MNRy	5	0	0	5	0	0	5	5	0	0	① Voltage; A, MNRy=A-V ₁	220	245	270	mV
	R-Y	MNRR	5	0	0	5	0	0	5	5	0	0	⑨ Voltage; B, MNRR=B-V ₉	-232	-209	-186	mV
	B-Y	MNRB	5	0	0	5	0	0	5	5	0	0	⑦ Voltage; C, MNRB=C-V ₇	28	50	72	mV
Blue	Y	MNBy	0	0	5	5	0	0	5	5	0	0	① Voltage; A, MNBy=A-V ₁	156	175	194	mV
	R-Y	MNBR	0	0	5	5	0	0	5	5	0	0	⑨ Voltage; B, MNBR=B-V ₉	13	33	53	mV
	B-Y	MNBB	0	0	5	5	0	0	5	5	0	0	⑦ Voltage; C, MNBB=C-V ₇	-165	-146	-127	mV
Black	Y	MNPY	0	0	0	5	0	0	5	5	0	0	① Voltage; A, MNPY=A-V ₁	-20	0	20	mV
	R-Y	MNPR	0	0	0	5	0	0	5	5	0	0	⑨ Voltage; B, MNPR=B-V ₉	-14	0	14	mV
	B-Y	MNPB	0	0	0	5	0	0	5	5	0	0	⑦ Voltage; C, MNPB=C-V ₇	-12	0	12	mV

■ EQUIVALENT CIRCUIT

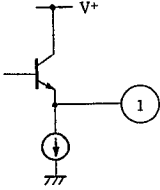
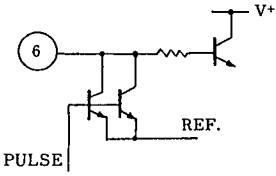
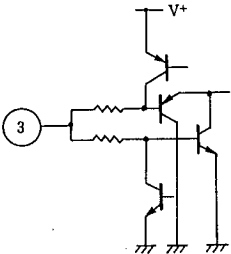
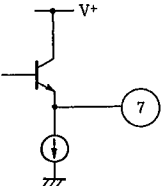
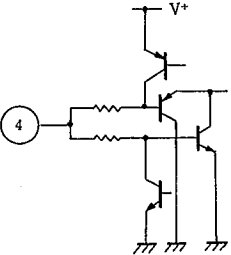
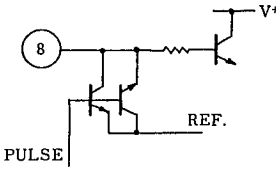
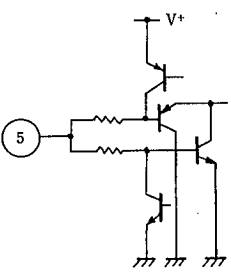
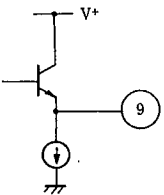
PIN NO.	PIN FUNCTION	INSIDE EQUIVALENT CIRCUIT	PIN NO.	PIN FUNCTION	INSIDE EQUIVALENT CIRCUIT
1	Y _{out}		6	B - Y _{in}	
2	V ⁺	_____			
3	R		7	B - Y _{out}	
4	G		8	R - Y _{in}	
5	B		9	R - Y _{out}	

5

■ EQUIVALENT CIRCUIT

PIN NO.	PIN FUNCTION	INSIDE EQUIVALENT CIRCUIT	PIN NO.	PIN FUNCTION	INSIDE EQUIVALENT CIRCUIT
10	C Inversion		15	Clamp Pulse	
			16	Character Pulse	
11	GND		17	Y _{in}	
12	HBF Pulse				
13	BF Level		18	Inversion Set up Correction	
14	NTSC/PAL				
19	Y Inversion		20	BLK	

5

■ INFORMATIONS

Following four points are the outstanding function of the NJM2247A/B. These functions are to go through three input (Y, R-Y, B-Y) signals control by ten control pins.

1. Color Superimpose
DC level of each equivalent colors shall be supplied to Y, R-Y and B-Y inputs.
2. Burst Flag Insertion
150 mV burst flag shall be added to R-Y, B-Y input signals.
Burst flag is selected by the NTSC/PAL switch.
3. C Inversion
The color phase of the picture shall be inverted for one hundred and eighty degrees. The color phase of the imposed character shall not be altered. This function shall be proceeded when inverting the burst flag, and at the same time, the imposed character level shall be inverted too.
4. Y Inversion
It is the brightness level inversion. The imposed character color shall not be changed. This function shall be proceeded the switching Y signal output to the inverter side.

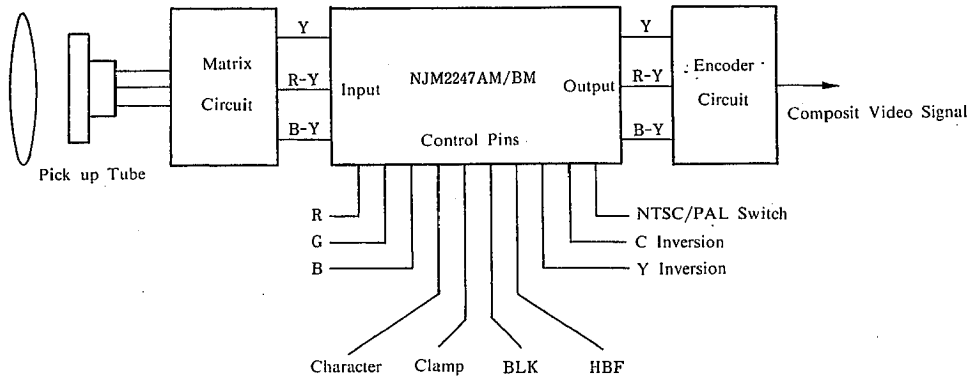

Fig. 1 Video Camera Application

■ APPLICATION NOTES

I/O Explanation

• Supply Voltage	V+	5V	②
	GND		⑩
• Input Signals	Y	0.7 V _{p-p}	⑬
	R-Y	1.0 V _{p-p}	⑧
	B-Y	0.7 V _{p-p}	⑥
• Output Signals	Y	0.7 V _{p-p}	①
	R-Y	1.0 V _{p-p}	⑨
	B-Y	0.7 V _{p-p}	⑦

APPLICATION NOTES

I/O Explanation

- Control Pin Low=0V, HIGH=5V

R^③
G^④
B^⑤ } Superimposed color adjustment

Clamp Pulse ^⑬
Character Pulse ^⑭
HBF Pulse ^⑮
BLK Pulse ^⑯ } Y, R-Y, B-Y signal process pulse input

C Inversion ^⑰
Y Inversion ^⑱ } Color difference, brightness inverting pin

NTS/PAL Switch

- Adjusting Pin (Normally open → non adjustment)
BF level ^⑲ Burst flag insert level adjusting pin.
Inversion set up correction ^⑳ Y inversion signal level adjusting pin.

1. Input Signal

Superimposed color level shall be determined by the following standard signal level.

Y 0.7V_{P-P}

R-Y 1.0V_{P-P}

B-Y 0.7V_{P-P}

The character output standard level on the specification shall be determined through calculation out of 75 % of superimposed color level.

(In order to avoid the clipping of the encoding signal, the character output level is determined to lower level)

- The character output level converting expression

The basic expression

$$E_R - E_Y = 0.70E_R - 0.59E_G - 0.11E_B$$

$$E_B - E_Y = -0.30E_R - 0.59E_G + 0.89E_B$$

$$E_Y = 0.30E_R + 0.59E_G + 0.11E_B$$

From standard level and practical input level, each color signal level imposed in R-Y, B-Y and Y signals are as in the following.

$$V_{R-Y} = 0.75 \times 1 [V_{P-P}] \times E_{R-Y} / 1.4$$

$$= 0.375E_R - 0.316E_G - 0.059E_B$$

$$V_{B-Y} = 0.75 \times 0.7 [V_{P-P}] \times E_{B-Y} / 1.78$$

$$= -0.088E_R - 0.174E_G + 0.263E_B$$

$$V_Y = 0.158E_R + 0.310E_G + 0.058E_B$$

$$(E_R, E_G, E_B \text{ は, LOW 0, HIGH 1})$$

2. Clamp Pulse

During the interval of blanking, input the pulse through clamp pulse pin ^⑳ the blanking level (0 level) of input signal (Y, R-Y, B-Y) is to be fixed at the bias point within the IC.

(Note) The pulse width of clamp pulse shall be set more than A version 6 μs and B version 3 μs. (see figure 2)

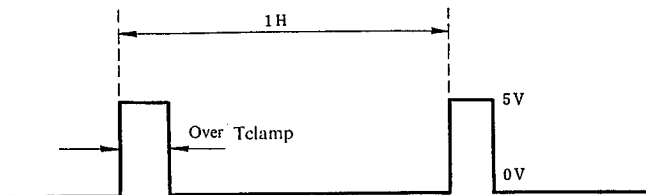

Fig. 2 Clamp Pulse Width

3. Character Color Adjustment

Superimposed color adjustment of the character can be determined in eight different colors, by choosing R, G, B input levels.

(LOW 0V, HIGH 5V)

R	G	B	COLOR
5	5	5	White
5	5	0	Yellow
0	5	5	Cyan
0	5	0	Green
5	0	5	Magenta
5	0	0	Red
0	0	5	blue
0	0	0	Black

Character Color Selecting Code

4. Character Insertion

Pulse informations from outside character generator shall be given input at the character pulse pin ⑩. During the period of pulse process, the selected color level shall be inserted into each Y, R-Y, B-Y.

5. Burst Flag Insertion

Inputting burst period pulse at the HBF pin ⑪, the burst flag (150mV) can be inserted in the B-Y, R-Y signals. At the same time, by putting NTSC/PAL switch ⑬, the burst flag can be altered to NTSC or PAL system.

	NTSC/PAL SWITCH⑬	
	LOW 0V (PAL)	HIGH 5V (NTSC)
R-Y Signal	+150 mV	non insertion
B-Y Signal	-150 mV	-150 mV

Burst Flag Inserting

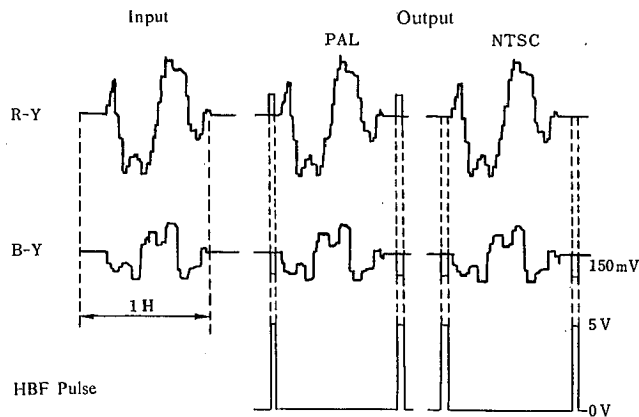

Fig.3 Burst Flag Inserting Example

6. C Inversion

The color phase of the picture shall be inverted for one hundred and eighty degrees setting C inversion pin ⑩. It is applied that the reference signal (burst flag) shall be inverted into one hundred and eighty degrees at the time of de-coding.

Superimposed character color do not change at the picture inversion.

	C INVERSION PIN ⑩	
	LOW 0V	HIGH 5V
Burst	Non Inversion	Inversion

C Inversion Form

7. Y Inversion

The brightness of the picture shall be inverted by setting Y inversion pin ⑪. It is that Y signal shall be inverted by the inverter, and then blanking period signal shall be adjusted to the black level with blanking pulse.

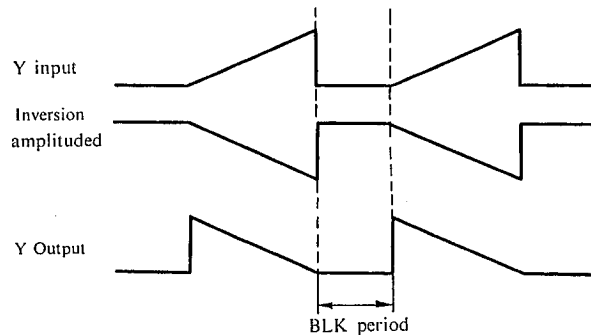

Figure 4. Y Inversion Output Example

	Y INVERSION PIN ⑪	
	LOW 0V	HIGH 5V
Y output	Non inversion	Inversion

Y Inversion Form

8. Adjusting pin

(1) BF Level Pin ⑬

It is the burst flag minor adjusting pin. The burst level shall be adjusted at the open voltage, 0.3V level adjustment. Therefore, the most recommended on operation with the open condition, as it has been controlled at 135 to 165 mV (burst level) on specification.

(2) Inversion Set Up Correction Pin ⑭

It is the minor adjusting pin of Y inversion signal level. The inverting black level shall be adjusted at the open voltage, 1.8 V level adjustment. Therefore, the most recommended on operation with the open condition, as it has been controlled with 0.59 to 0.77 V (inverting black level) on specification.

9. Pulse Timing

The pulse input timing should be proceeded as in the following.

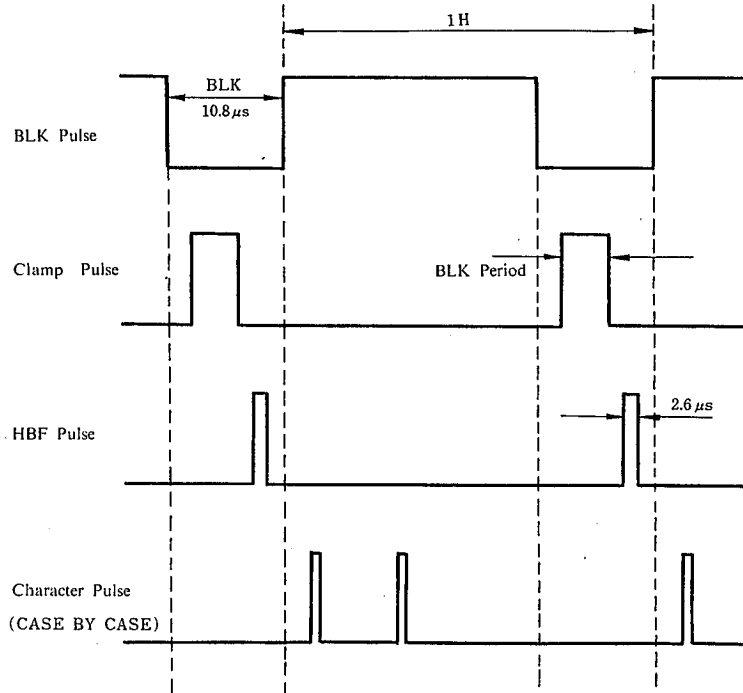

■ TYPICAL APPLICATION

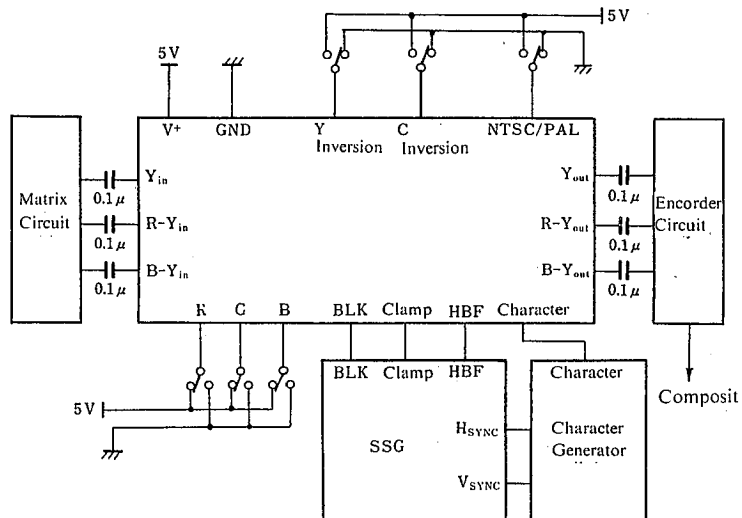

MEMO

[CAUTION]

The specifications on this databook are only given for information, without any guarantee as regards either mistakes or omissions. The application circuits in this databook are described only to show representative usages of the product and not intended for the guarantee or permission of any right including the industrial rights.