

3-INPUT VIDEO SWITCH

■ GENERAL DESCRIPTION

The NJM2234 is 3-input video switch selecting one of three input video or audio signals. Its operating supply voltage range is 5 to 12V and bandwidth is 10MHz. Crosstalk is 70dB (at 4.43MHz).

■ FEATURES

- Operating Voltage (+4.75V~+13V)
- 3 Input-1 Output
- Muting Function available
- Wide Operating Supply Voltage Range 4.75~13V
- Cross-talk 70dB (at 4.43MHz)
- Muting Function available
- Package Outline DIP-8, DMP-8, SIP-8, SSOP-8
- Bipolar Technology

■ APPLICATION

- VCR Video Camera AV-TV Video Disc Player Audio

■ PIN CONFIGURATION

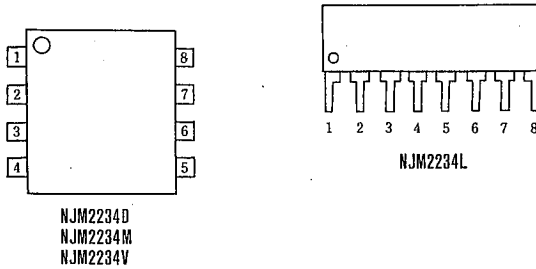

■ PACKAGE OUTLINE

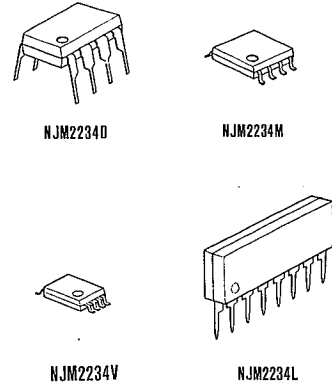

PIN FUNCTION

1. V_{in1}
2. SW1
3. V_{in2}
4. SW2
5. V_{in3}
6. V^+
7. V_{out}
8. GND

■ BLOCK DIAGRAM

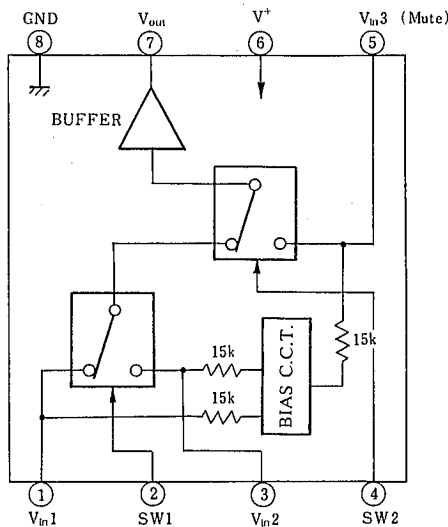

■ ABSOLUTE MAXIMUM RATINGS

(Ta=25°C)

PARAMETER	SYMBOL	RATINGS	UNIT
Supply Voltage	V*	15	V
Power Dissipation	P _D	(DIP8) 500 (DMP8) 300 (SSOP8) 250 (SIP8) 800	mW mW mW mW
Operating Temperature Range	T _{opr}	-20~+75	°C
Storage Temperature Range	T _{stg}	-40~+125	°C

■ ELECTRICAL CHARACTERISTICS

(V*=5V, Ta=25°C)

PARAMETER	SYMBOL	TEST CONDITION	MIN.	TYP.	MAX.	UNIT
Recommended Supply Voltage	V*		4.75	—	13.0	V
Operating Current	I _{CC}	S1=S2=S3=S4=S5=1	—	11.0	14.5	mA
Frequency Characteristics (1)	G _{f1}	V _i =2.5V _{pp} V _o (20Hz)/V _o (100kHz)	-1.0	—	+1.0	dB
Frequency Characteristics (2)	G _{f2}	V _i =2.0V _{pp} V _o (10MHz)/V _o (100kHz)	-1.0	—	+1.0	dB
Voltage Gain	G _v	V _i =2.5V _{pp} , 100kHz V _o /V _i	-0.5	—	+0.5	dB
Total Harmonic Distortion	THD	V _i =2.5V _{pp} , 1kHz	—	0.03	—	%
Differential Gain	DG	V _i =2V _{pp} Staircase signal	—	0	—	%
Differential Phase	DP	V _i =2V _{pp} Staircase signal	—	0	—	deg
Output Offset Voltage	V _{off}	(note 2)	-30	—	+30	mV
Crosstalk (1)	CT1	V _i =2.0V _{pp} , 4.43MHz, V _o /V _i (note 3)	—	-70	—	dB
Crosstalk (2)	CT2	V _i =2.0V _{pp} , 4.43MHz, V _o /V _i (note 4)	—	-70	—	dB
Switch Change Voltage	V _{CH}	All inside SW : ON	2.4	—	—	V
	V _{CL}	All inside SW : OFF	—	—	0.8	V
Input Impedance	R _i		—	15	—	kΩ
Output Impedance	R _o		—	10	—	Ω

(note 1): If it is not shown about switch condition, it is tested on three condition below.

a) S1=2, S2=S3=S4=S5=1 b) S2=S4=2, S1=S3=S5=1, c) S3=S5=2, S1=S2=1, S4=1 or 2.

(note 2): S1=S2=S3=1, Output DC voltage difference of three mode below.

a) S4=S5=1 b) S4=2, S5=1 c) S4=1 or 2, S5=2

(note 3): S5=1, Tested on all combination of S1~S4 excepted two below.

a) S1=2, S4=1 b) S2=S4=2

(note 4): Tested on all combination of S1~S4 excepted one.

a) S5=2, S3=2

■ INPUT CONTROL SIGNAL - OUTPUT SIGNAL

SW 1	SW 2	OUTPUT SIGNAL
L	L	V _{IN 1}
H	L	V _{IN 2}
L/H	H	V _{IN 3}

■ TEST CIRCUIT

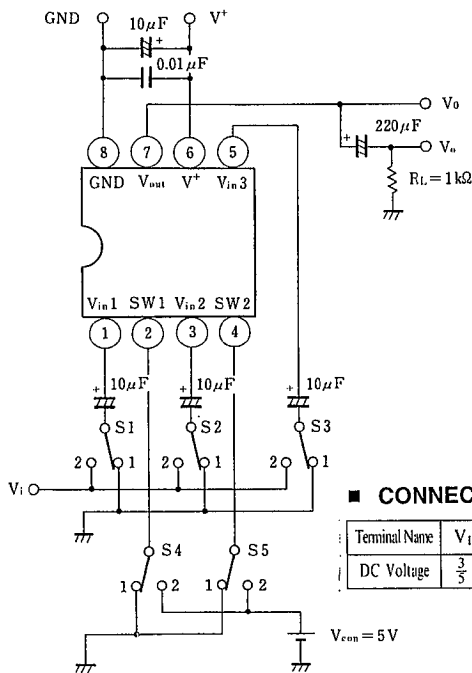

■ CONNECTION DIAGRAM

Terminal Name	V _{IN 1}	SW1	V _{IN 2}	SW2	V _{IN 3}	V ⁺	V _{OUT}	GND
DC Voltage	$\frac{3}{5} V^+$	—	$\frac{3}{5} V^+$	—	$\frac{3}{5} V^+$	—	$\frac{3}{5} V^+ - 0.7$	—

■ APPLICATION

Oscillation Prevention on light loading conditions
Recommended under circuit

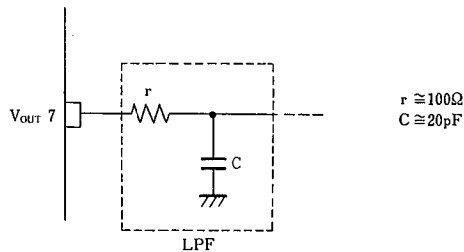

■ EQUIVALENT CIRCUIT

PIN NO.	PIN FUNCTION	INSIDE EQUIVALENT CIRCUIT	PIN NO.	PIN FUNCTION	INSIDE EQUIVALENT CIRCUIT
1	V _{IN 1}		5	V _{IN 3} (Mute)	
2	SW 1		6	V+	
3	V _{IN 2}		7	V _{OUT}	
4	SW 2		8	GND	

MEMO

[CAUTION]

The specifications on this databook are only given for information, without any guarantee as regards either mistakes or omissions. The application circuits in this databook are described only to show representative usages of the product and not intended for the guarantee or permission of any right including the industrial rights.