

## 2M-BIT MASK ROM (8 BIT OUTPUT)

### FEATURES

- Bit organization
  - 256K x 8 (byte mode)
- Fast access time
  - Random access: 70ns (max.)
- Current
  - Operating: 40mA
  - Standby: 100uA
  - (50uA for PLCC)
- Supply voltage
  - 5V ± 10%
- Package
  - 32 pin PDIP (600 mil)
  - 32 pin PLCC
  - 32 pin SOP (450 mil)
  - 32 pin TSOP (8mm x 20mm)

### PIN CONFIGURATION

#### 32 PDIP / 32 SOP

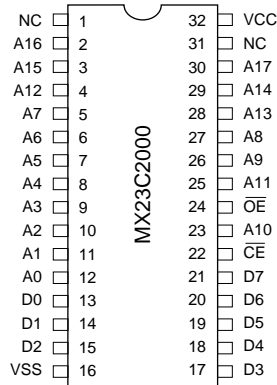

#### 32 PLCC

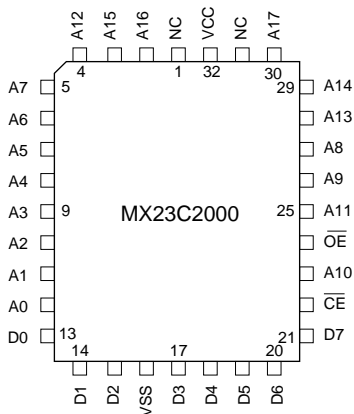

### ORDER INFORMATION

Part No.	Access Time	Package
MX23C2000PC-70	70ns	32 pin PDIP
MX23C2000PC-90	90ns	32 pin PDIP
MX23C2000PC-10	100ns	32 pin PDIP
MX23C2000PC-12	120ns	32 pin PDIP
MX23C2000PC-15	150ns	32 pin PDIP
MX23C2000QC-70	70ns	32 pin PLCC
MX23C2000QC-90	90ns	32 pin PLCC
MX23C2000QC-10	100ns	32 pin PLCC
MX23C2000QC-12	120ns	32 pin PLCC
MX23C2000QC-15	150ns	32 pin PLCC
MX23C2000MC-70	70ns	32 pin SOP
MX23C2000MC-90	90ns	32 pin SOP
MX23C2000MC-10	100ns	32 pin SOP
MX23C2000MC-12	120ns	32 pin SOP
MX23C2000MC-15	150ns	32 pin SOP
MX23C2000TC-70	70ns	32 pin TSOP
MX23C2000TC-90	90ns	32 pin TSOP
MX23C2000TC-10	100ns	32 pin TSOP
MX23C2000TC-12	120ns	32 pin TSOP
MX23C2000TC-15	150ns	32 pin TSOP

### PIN DESCRIPTION

Symbol	Pin Function
A0~A17	Address Inputs
D0~D7	Data Outputs
$\overline{CE}$	Chip Enable Input
$\overline{OE}$	Output Enable Input
$\overline{VCC}$	Power Supply Pin
VSS	Ground Pin
NC	No Connection

## 32 TSOP



## ABSOLUTE MAXIMUM RATINGS

Item	Symbol	Ratings
Power Supply Voltage	VCC	-0.5V to 7.0V
Input Voltage	VI	-0.5V to VCC + 0.5V
Output Voltage	VO	-0.5V to VCC + 0.5V
Ambient Operating Temperature	Topr	-10°C to 70°C
Storage Temperature	Tstg	-65°C to 125°C

## DC CHARACTERISTICS (Ta = 0°C ~ 70°C, VCC = 5.0V ± 10%)

Item	Symbol	MIN.	MAX.	Conditions
Output High Voltage	VOH	0.8VCC	-	IOH = -1.0mA
Output Low Voltage	VOL	-	0.4V	IOL = 2.1mA
Input High Voltage	VIH	2.2V	VCC+0.5V	
Input Low Voltage	VIL	-0.3V	0.8V	
Input Leakage Current	ILI	-	5uA	0V, VCC
Output Leakage Current	ILO	-	5uA	0V, VCC
Operating Current	ICC1	-	40mA	tRC = 100ns, all output open
Standby Current (TTL)	ISTB1	-	1mA	CE = VIH
Standby Current (CMOS)	ISTB2	-	100uA*	CE > VCC - 0.2V
Input Capacitance	CIN	-	10pF	Ta = 25°C, f = 1MHz
Output Capacitance	COUT	-	10pF	Ta = 25°C, f = 1MHz

Note : ISTB2 spec is 50uA(max.) for the PLCC package type

## AC CHARACTERISTICS (Ta = 0°C ~ 70°C , VCC = 5.0V ± 10%)

Item	Symbol	23C2000-70*		23C2000-90		23C2000-10		23C2000-12		23C2000-15	
		MIN.	MAX.	MIN.	MAX.	MIN.	MAX.	MIN.	MAX.	MIN.	MAX.
Read Cycle Time	tRC	70ns	-	90ns	-	100ns	-	120ns	-	150ns	-
Address Access Time	tAA	-	70ns	-	90ns	-	100ns	-	120ns	-	150ns
Chip Enable Access Time	tACE	-	70ns	-	90ns	-	100ns	-	120ns	-	150ns
Output Enable Time	tOE	-	30ns	-	45ns	-	50ns	-	60ns	-	70ns
Output Hold After Address	tOH	0ns	-	0ns	-	0ns	-	0ns	-	0ns	-
Output High Z Delay	tHZ	-	20ns	-	20ns	-	20ns	-	20ns	-	20ns

Note : Output high-impedance delay (tHZ) is measured from  $\overline{OE}$  or  $\overline{CE}$  going high, and this parameter guaranteed by design over the full voltage and temperature operating range - not tested.

\* 70ns speed grade is under development.

### AC Test Conditions

- Input Pulse Levels : 0.4V~2.4V  
0V~3V (for 70ns)
- Input Rise and Fall Times : 10ns
- Input Timing Level : 1.5V
- Output Timing Level : 0.8V and 2.0V  
1.5V (for 70ns)
- Output Load : See Figure

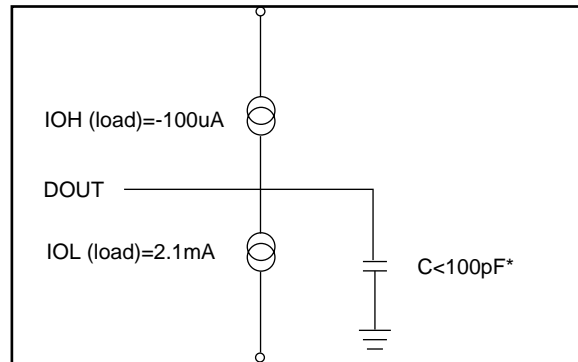

Note: No output loading is present in tester load board.

Active loading is used and under software programming control.

Output loading capacitance includes load board's and all stray capacitance.

\* CL=30pF for 70ns

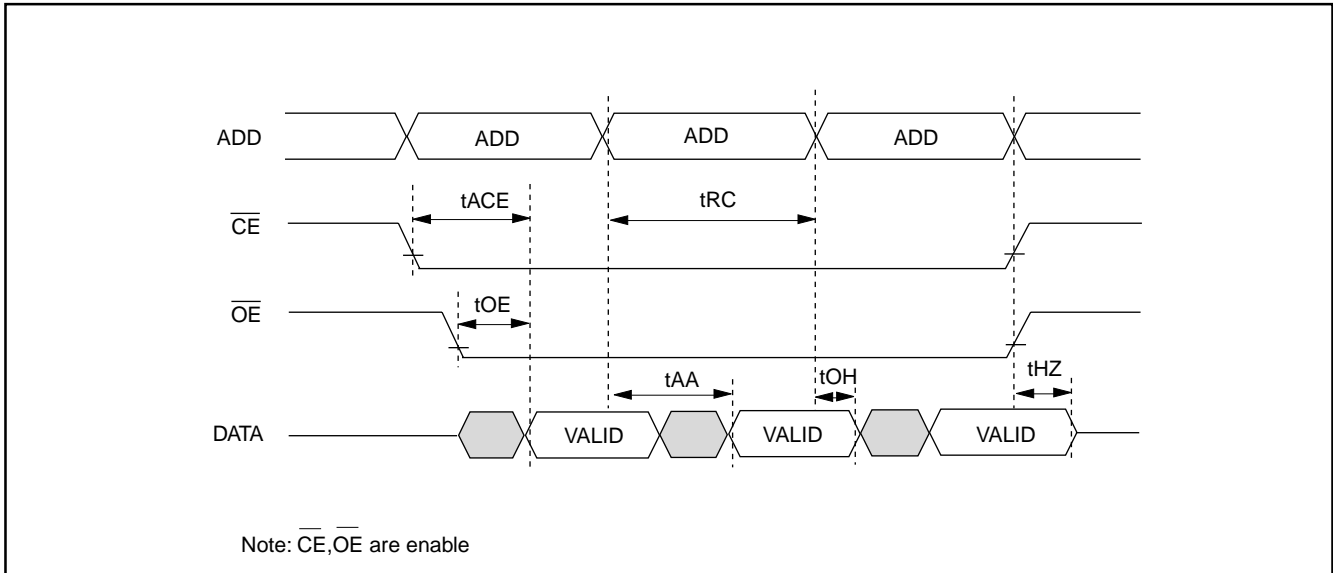
**TIMING DIAGRAM  
RANDOM READ**

## PACKAGE INFORMATION

### 32-PIN PLASTIC SOP (450 mil)

ITEM	MILLIMETERS	INCHES
A	20.95 max.	.825 max.
B	1.00 [REF]	.039 [REF]
C	1.27 [TP]	.050 [TP]
D	.40 [Typ.]	.016 [Typ.]
E	.05 min.	.002 min.
F	3.05 max.	.120 max.
G	2.69±.13	.106±.005
H	14.12±.25	.556±.010
I	11.30±.13	.445±.005
J	1.42	.056
K	.20 [Typ.]	.008 [Typ.]
L	.79	.031

**NOTE:** Each lead centerline is located within .25 mm [.01 inch] of its true position [TP] at maximum material condition.

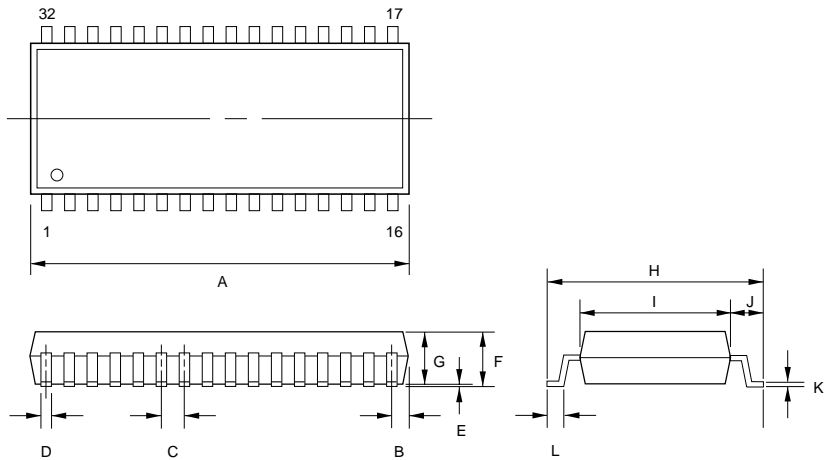

### 32-PIN PLASTIC DIP (600 mil)

ITEM	MILLIMETERS	INCHES
A	42.13 max.	1.660 max.
B	1.90 [REF]	.075 [REF]
C	2.54 [TP]	.100 [TP]
D	.46 [Typ.]	.018 [Typ.]
E	38.07	1.500
F	1.27 [Typ.]	.050 [Typ.]
G	3.30±.25	.130±.010
H	.51 [REF]	.020 [REF]
I	3.94±.25	.155±.010
J	5.33 max.	.210 max.
K	15.22±.25	.600±.010
L	13.97±.25	.550±.010
M	.25 [Typ.]	.010 [Typ.]

**NOTE:** Each lead centerline is located within .25 mm [.01 inch] of its true position [TP] at maximum material condition.

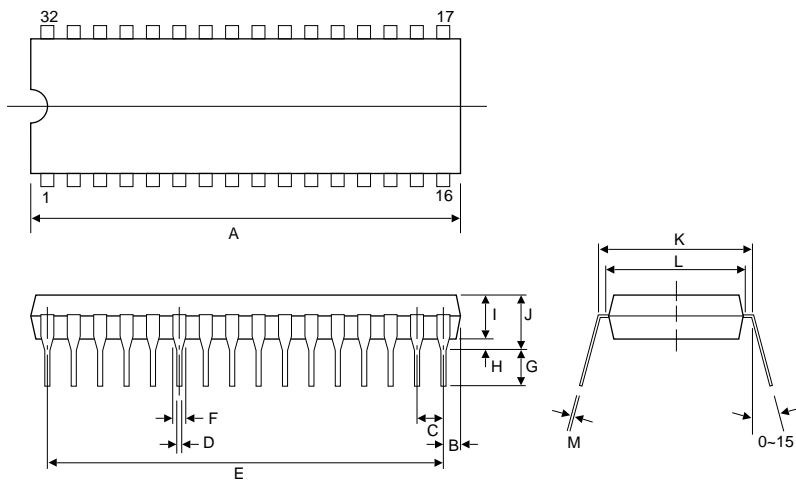

## 32-PIN PLASTIC LEADED CHIP CARRIER (PLCC)

ITEM	MILLIMETERS	INCHES
A	12.44±.13	.490±.005
B	11.50±.13	.453±.005
C	14.04±.13	.553±.13
D	14.98±.13	.590±.13
E	1.93	.076
F	3.30±.25	.130±.010
G	2.03±.13	.080±.005
H	.51±.13	.020±.005
I	1.27 [Typ.]	.050 [Typ.]
J	.71 [REF]	.028 [REF]
K	.46 [REF]	.018 [REF]
L	10.40/12.94	.410/.510
	(W) (L)	(W) (L)
M	.89 R	.035 R
N	.25 [TYP.]	.010 [TYP.]

**NOTE:** Each lead centerline is located within .25 mm [.01 inch] of its true position [TP] at maximum material condition.

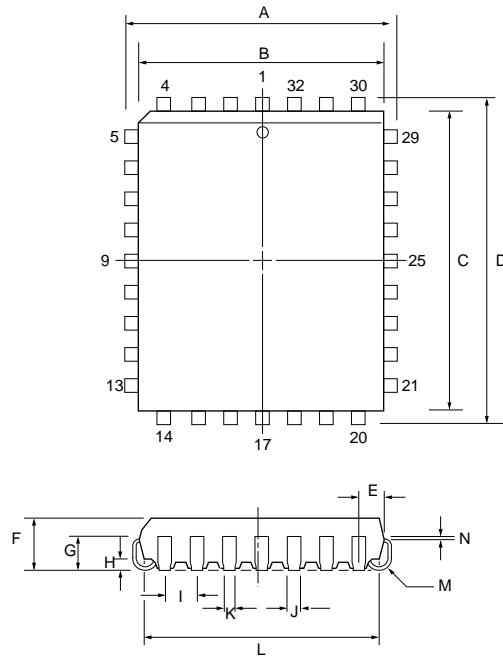



**REVISION HISTORY**

<b>REVISION</b>	<b>DESCRIPTION</b>	<b>PAGE</b>	<b>DATE</b>
3.7	To add 70ns speed grade.	P3	NOV/16/1998
3.8	Loading=30pF for 70ns.	P3	NOV/23/1998
3.9	AC Characteristics: tOH 10ns --> 0ns	P3	JAN/29/1999



**MX23C2000**

---

---

**MACRONIX INTERNATIONAL Co., LTD.**

**HEADQUARTERS:**

TEL:+886-3-578-8888

FAX:+886-3-578-8887

**EUROPE OFFICE:**

TEL:+32-2-456-8020

FAX:+32-2-456-8021

**JAPAN OFFICE:**

TEL:+81-44-246-9100

FAX:+81-44-246-9105

**SINGAPORE OFFICE:**

TEL:+65-747-2309

FAX:+65-748-4090

**TAIPEI OFFICE:**

TEL:+886-3-509-3300

FAX:+886-3-509-2200

**MACRONIX AMERICA, INC.**

TEL:+1-408-453-8088

FAX:+1-408-453-8488

**CHICAGO OFFICE:**

TEL:+1-847-963-1900

FAX:+1-847-963-1909

**[http : //www.macronix.com](http://www.macronix.com)**