

General Description

The MIC2557 switches the four voltages required by PCMCIA (Personal Computer Memory Card International Association) card V_{PP} Pins. The MIC2557 provides selectable 0V, 3.3V, 5.0V, or 12.0V ($\pm 5\%$) from the system power supply to V_{PP1} or V_{PP2} . Output voltage is selected by two digital inputs. Output current ranges up to 120mA. Four control states, V_{PP} , V_{CC} , high impedance, and active logic low are available. An auxiliary control input determines whether the high impedance (open) state or low logic state is asserted.

In either quiescent mode or full operation, the device draws very little current, typically less than 1 μ A.

The MIC2557 is available in an 8-pin SOIC and an 8-pin plastic DIP.

Applications

- PCMCIA V_{PP} Pin Voltage Switch
- Power Supply Management
- Power Analog Switch

Features

- Complete PCMCIA V_{PP} Switch Matrix in a Single IC
- No External Components Required
- Digital Selection of 0V, V_{CC} , V_{PP} , or High Impedance Output
- No $V_{PP\ OUT}$ Overshoot or Switching Transients
- Break-Before-Make Switching
- Low Power Consumption
- 120mA V_{PP} (12V) Output Current
- Optional Active Source Clamp for Zero Volt Condition
- 3.3V or 5V Supply Operation
- 8-Pin SOIC Package

Ordering Information

Part Number	Temperature Range	Package
MIC2557BM	-40°C to +85°C	8-pin SOIC
MIC2557BM T&R	-40°C to +85°C	8-SOIC Tape & Reel*

* 2,500 Parts per reel.

Typical Application

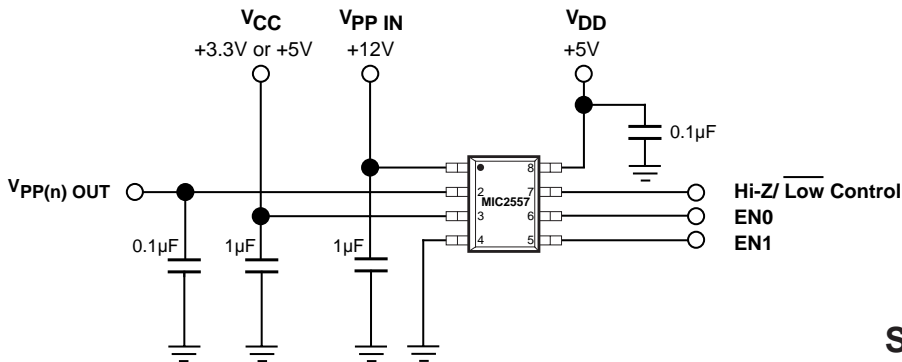

Pin Configuration

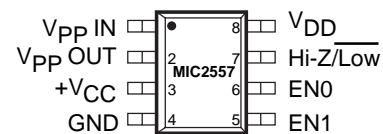

Simplified Block Diagram

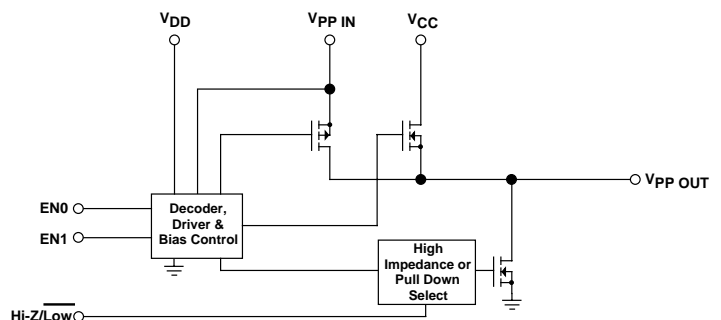

EN1	EN0	Hi-Z/Low	$V_{PP\ OUT}$
0	0	0	0V, (Sink current)
0	0	1	Hi-Z (No Connect)
0	1	x	V_{CC} (3.3V or 5.0V)
1	0	x	V_{PP}
1	1	x	Hi-Z (No Connect)

For a dual PCMCIA Card Socket V_{PP} Switching Matrix, see the MIC2558.

For a V_{PP} and V_{CC} Switching Matrix, see the MIC2560.

Absolute Maximum Ratings (Notes 1 and 2)

Power Dissipation, $T_{AMBIENT} \leq 25^{\circ}C$	
SOIC	800 mW
Derating Factors (To Ambient)	
SOIC	4 mW/ $^{\circ}C$
Storage Temperature	-65 $^{\circ}C$ to +150 $^{\circ}C$
Operating Temperature (Die)	125 $^{\circ}C$
Operating Temperature (Ambient)	-40 $^{\circ}C$ to +85 $^{\circ}C$
Lead Temperature (5 sec)	260 $^{\circ}C$
Supply Voltage, $V_{PP IN}$	15V
V_{CC}	7.5V
V_{DD}	7.5V
Logic Input Voltages	-0.3V to V_{DD}
Output Current	
$V_{PP OUT} = 12V$	600mA
$V_{PP OUT} = V_{CC}$	250mA

Logic Block Diagram

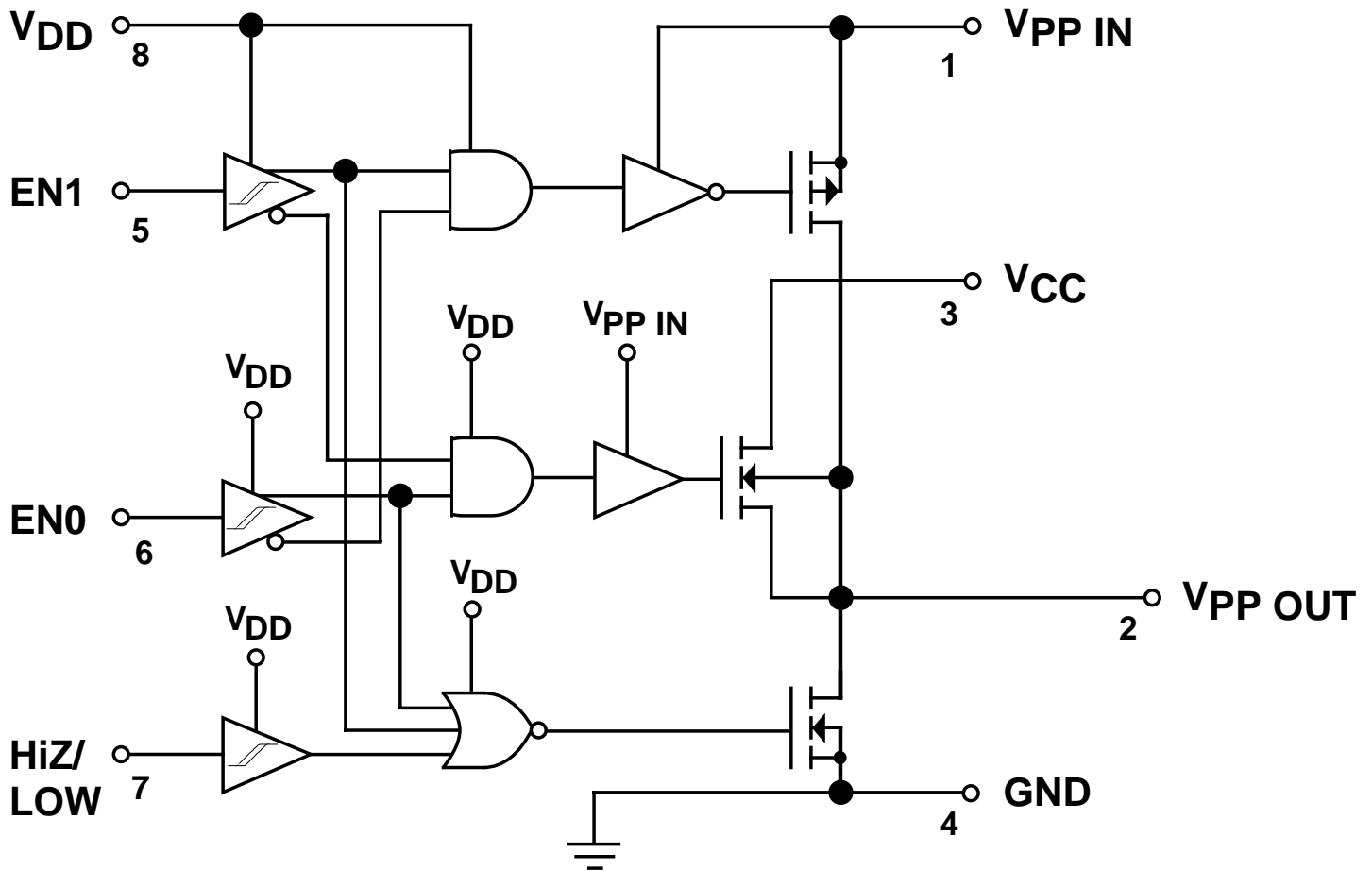

Electrical Characteristics: (Over operating temperature range with $V_{DD} = V_{CC} = 5V$, $V_{PPIN} = 12V$ unless otherwise specified.)

Symbol	Parameter	Conditions	Min	Typ	Max	Units
INPUT						
V_{IH}	Logic 1 Input Voltage	$V_{DD} = 3.3V$ or $5.0V$	2.2			V
V_{IL}	Logic 0 Input Voltage	$V_{DD} = 3.3V$ or $5.0V$			0.8	V
V_{IN} (Max)	Input Voltage Range		-5		V_{DD}	V
I_{IN}	Input Current	$0V < V_{IN} < V_{DD}$			± 1	μA
OUTPUT						
V_{OL}	Clamp Low Output Voltage	$EN0 = EN1 = HiZ = 0$, $I_{SINK} = 1.6mA$			0.4	V
I_{OUT} , Hi-Z	High Impedance Output Leakage Current	$EN0 = EN1 = 0$, $HiZ = 1$ $0 \leq V_{PPOUT} \leq 12V$		1	10	μA
R_{OC}	Clamp Low Output Resistance	Resistance to Ground. $I_{SINK} = 2mA$ $EN0 = EN1 = 0, HiZ = 0$		130	250	Ω
R_O	Switch Resistance, $V_{PPOUT} = V_{CC}$	$I_{PPOUT} = -10mA$ (Sourcing)		2.5	5	Ω
R_O	Switch Resistance, $V_{PPOUT} = V_{PPIN}$	$I_{PPOUT} = -100mA$ (Sourcing)		0.5	1	Ω
SWITCHING TIME (See Figure 1)						
t_1	Delay + Rise Time	$V_{PPOUT} = 0V$ to $5V$ (Notes 3, 5)		15	50	μs
t_2	Delay + Rise Time	$V_{PPOUT} = 5V$ to $12V$ (Notes 3, 5)		12	50	μs
t_3	Delay + Fall Time	$V_{PPOUT} = 12V$ to $5V$ (Notes 3, 5)		25	75	μs
t_4	Delay + Fall Time	$V_{PPOUT} = 5V$ to $0V$ (Notes 3, 5)		45	100	μs
t_5	Output Turn-On Delay	$V_{PPOUT} = Hi-Z$ to $5V$ (Notes 4, 5)		10	50	μs
t_6	Output Turn-Off Delay	$V_{PPOUT} = 5V$ to $Hi-Z$ (Notes 4, 5)		75	200	ns
POWER SUPPLY						
I_{DD}	V_{DD} Supply Current			-	1	μA
I_{CC}	V_{CC} Supply Current	$I_{PPOUT} = 0$		-	1	μA
I_{PP}	I_{PP} Supply Current	$V_{PPOUT} = 0V$ or $V_{PP} \cdot I_{PPOUT} = 0$.		-	10	μA
			$V_{PPOUT} = V_{CC}$	10	40	μA

Electrical Characteristics, (continued)

Symbol	Parameter	Conditions	Min	Typ	Max	Units
POWER SUPPLY, continued						
V_{CC}	Operating Input Voltage				6	V
V_{DD}	Operating Input Voltage		2.8		6	V
$V_{PP\ IN}$	Operating Input Voltage		8.0		14.5	V

- NOTE 1:** Functional operation above the absolute maximum stress ratings is not implied.
- NOTE 2:** Static-sensitive device. Store only in conductive containers. Handling personnel and equipment should be grounded to prevent damage from static discharge.
- NOTE 3:** With $R_L = 2.9k\Omega$ and $C_{OUT} = 0.1\mu F$ on $V_{PP\ OUT}$.
- NOTE 4:** $R_L = 2.9k\Omega$. R_L is connected to V_{CC} during t_5 , and is connected to ground during t_6 .
- NOTE 5:** Rise and fall times are measured to 90% of the difference between initial and final values.

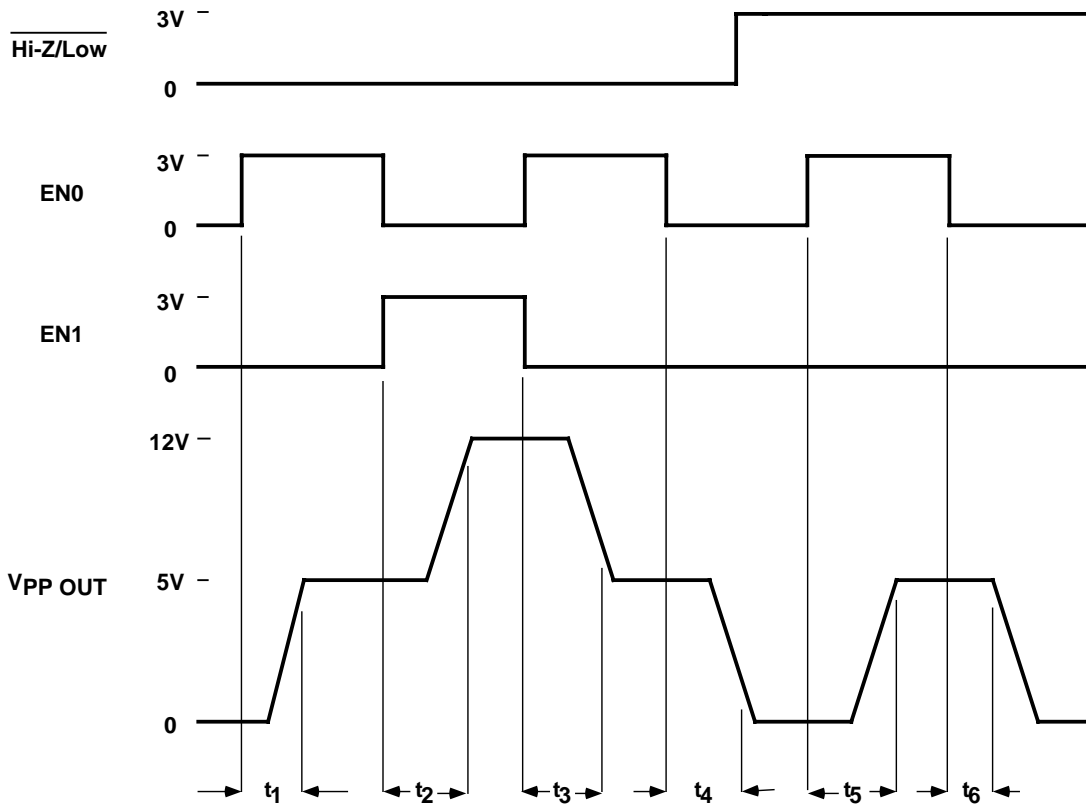

Figure 1. Timing Diagram

Applications Information

PCMCIA V_{PP} control is easily accomplished using the MIC2557 voltage selector/switch IC. Two control bits determine output voltage and standby/operate mode condition. Output voltages of 0V (defined as less than 0.4V), V_{CC} (3.3V or 5V), V_{PP} , or a high impedance state, are available. When either the high impedance or low voltage conditions are selected, the device switches into "sleep" mode, and draws only nanoamperes of leakage current.

The MIC2557 is a low-resistance power MOSFET switching matrix that operates from the computer system main power supply. Device power is obtained from V_{DD} , which may be either 3.3V or 5V, and FET drive is obtained from $V_{PP\ IN}$ (usually +12V). Internal break-before-make switches determine the output voltage and device mode.

Supply Bypassing

For best results, bypass V_{CC} and $V_{PP\ IN}$ at their inputs with $1\mu\text{F}$ capacitors. $V_{PP\ OUT}$ should have a $0.01\mu\text{F}$ to $0.1\mu\text{F}$ capacitor for noise reduction and electrostatic discharge (ESD) damage prevention. Larger values of output capacitor will create large current spikes during transitions, requiring larger bypass capacitors on the V_{CC} and $V_{PP\ IN}$ pins.

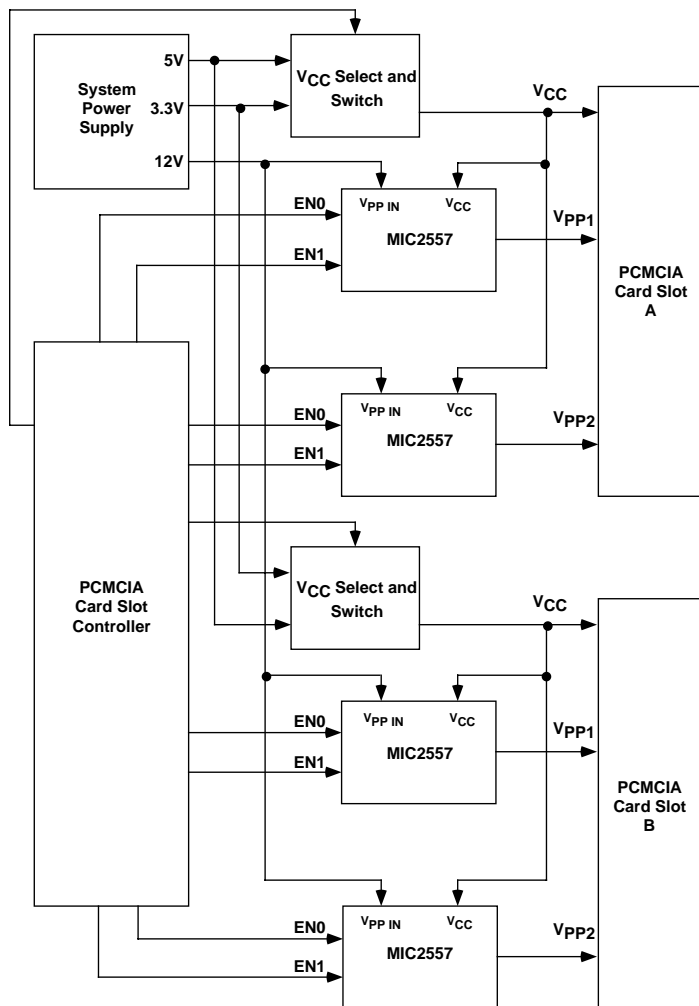

Figure 2. MIC2557 Typical two slot PCMCIA application with dual V_{CC} (5.0V or 3.3V).

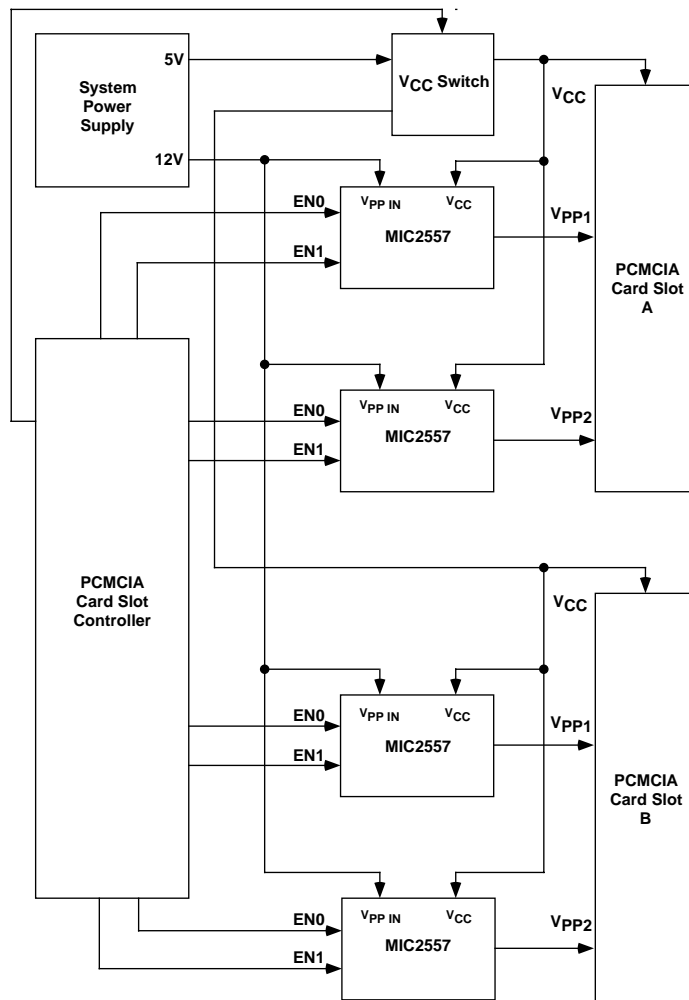

Figure 3. MIC2557 Typical two slot PCMCIA application with single 5.0V V_{CC} .

PCMCIA Implementation

The Personal Computer Memory Card International Association (PCMCIA) specification requires two V_{PP} supply pins per PCMCIA slot. V_{PP} is primarily used for programming Flash (EEPROM) memory cards. The two V_{PP} supply pins may be programmed to different voltages. Fully implementing PCMCIA specifications requires two MIC2557, and a controller. Figure 2 shows this full configuration, supporting both 5.0V and 3.3V V_{CC} operation. Figure 3 is a simplified design with fixed $V_{CC} = 5V$. Palmtop computers, where size and battery life are tantamount, can sometimes use a compromise implementation, with V_{PP1} tied to V_{PP2} (see Figure 4).

When a memory card is initially inserted, it should receive V_{CC} , usually $5.0V \pm 5\%$. The card sends a handshaking data stream to the controller, which then determines whether or not this card requires V_{PP} and if the card is designed for 5.0V or 3.3V V_{CC} . If the card uses 3.3V V_{CC} , the controller commands this change, which is reflected on the V_{CC} pins of both the PCMCIA slot and the MIC2557.

During Flash memory programming, the PCMCIA controller outputs a (1,0) to the MIC2557, which connects $V_{PP\ IN}$ to

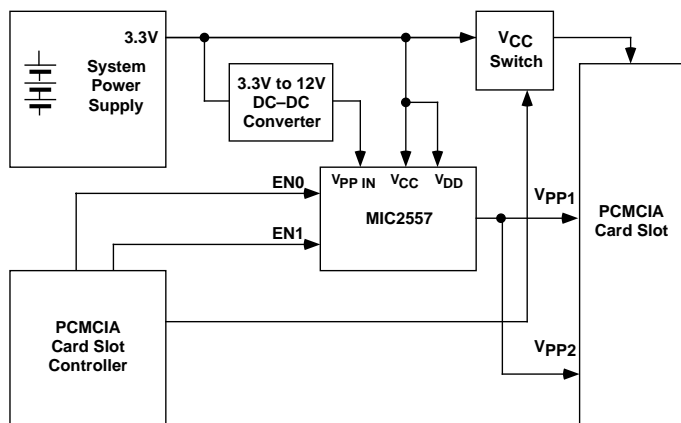

Figure 4. MIC2557 Palmtop application. Note that the V_{PP1} and V_{PP2} pins are combined. Although this does not fully satisfy PCMCIA specifications, it simplifies the circuitry and is acceptable in certain applications.

$V_{PP\ OUT}$. The low ON resistance of the MIC2557 switch requires only a small bypass capacitor on $V_{PP\ OUT}$, with the main filtering action performed by a large filter capacitor on $V_{PP\ IN}$. The $V_{PP\ OUT}$ transition from V_{CC} to 12.0V typically takes 25 μ S. After programming is completed, the controller outputs a (0,1) to the MIC2557, which then reduces $V_{PP\ OUT}$ to the V_{CC} level. Break-before-make switching action reduces switching transients and lowers maximum current spikes through the switch from the output capacitor.

If no card is inserted, or the system is in sleep mode, the controller outputs either a (0,0) or a (1,1) to the MIC2557. Either input places the switch into its shutdown mode, where only a small leakage current flows.

The HiZ/Low input controls the optional logic low output clamp. With HiZ/Low in the high state and $EN0 = EN1 = 0$, $V_{PP\ OUT}$ enters a high impedance (open) state. With HiZ/Low in the low state and $EN0 = EN1 = 0$, $V_{PP\ OUT}$ is clamped to ground, providing a logic low signal. The clamp does not require DC bias current for operation.

MOSFET drive and bias voltage is derived from $V_{PP\ IN}$. Internal device control logic is powered from V_{DD} , which should be connected to the same supply voltage as the PCMCIA controller (normally either 3.3V or 5V).

Output Current

MIC2557 output switches are capable of far more current than usually needed in PCMCIA applications. PCMCIA V_{PP} output current is limited primarily by switch resistance voltage drop ($I \times R$) and the requirement that $V_{PP\ OUT}$ cannot drop more than 5% below nominal. $V_{PP\ OUT}$ will survive output short circuits to ground if $V_{PP\ IN}$ and V_{CC} are current limited by the regulator that supplies these voltages.