TABLE OF CONTENTS

| | |
|---|---------------|
| PIN ASSIGNMENTS AND SIGNAL DESCRIPTIONS | 11-109 |
| FUNCTIONAL DESCRIPTION | 11-112 |
| Introduction | 11-112 |
| Controller Compatibility Modes | 11-112 |
| Transmit Function | 11-112 |
| Jabber Control Function | 11-113 |
| Receive Function | 11-113 |
| SQE Function | 11-113 |
| Polarity Reverse Function | 11-114 |
| Loopback Function | 11-114 |
| Collision Detection Function | 11-114 |
| Link Integrity Test Function | 11-115 |
| APPLICATION INFORMATION | 11-116 |
| External Components | 11-116 |
| Layout Requirements | 11-116 |
| Auto Port Select with External Loopback Control | 11-116 |
| Full - Duplex Support | 11-118 |
| Dual Network Support - 10BASE-T and Token Ring | 11-119 |
| Manual Port Select & Link Test Function | 11-120 |
| Three Media Application | 11-122 |
| AUI Encoder/Decoder Only | 11-123 |
| TEST SPECIFICATIONS | 11-124 |
| Absolute Maximum Values | 11-124 |
| Recommended Operating Conditions | 11-124 |
| I/O Electrical Characteristics | 11-124 |
| AUI Electrical Characteristics | 11-125 |
| Twisted-Pair Electrical Characteristics | 11-125 |
| Switching Characteristics | 11-126 |
| RCLK/Start-of-Frame Timing | 11-126 |
| RCLK/End-of-Frame Timing | 11-126 |
| Transmit Timing | 11-127 |
| Collision, COL/CI Output and Loopback Timing | 11-127 |
| Mode 1 Timing Diagrams | 11-128 |
| Mode 2 Timing Diagrams | 11-130 |
| Mode 3 Timing Diagrams | 11-132 |
| Mode 4 Timing Diagrams | 11-134 |
| Mode 5 Timing Diagrams | 11-136 |

PIN ASSIGNMENTS AND SIGNAL DESCRIPTIONS

Figure 1: LXT908 Pin Assignments

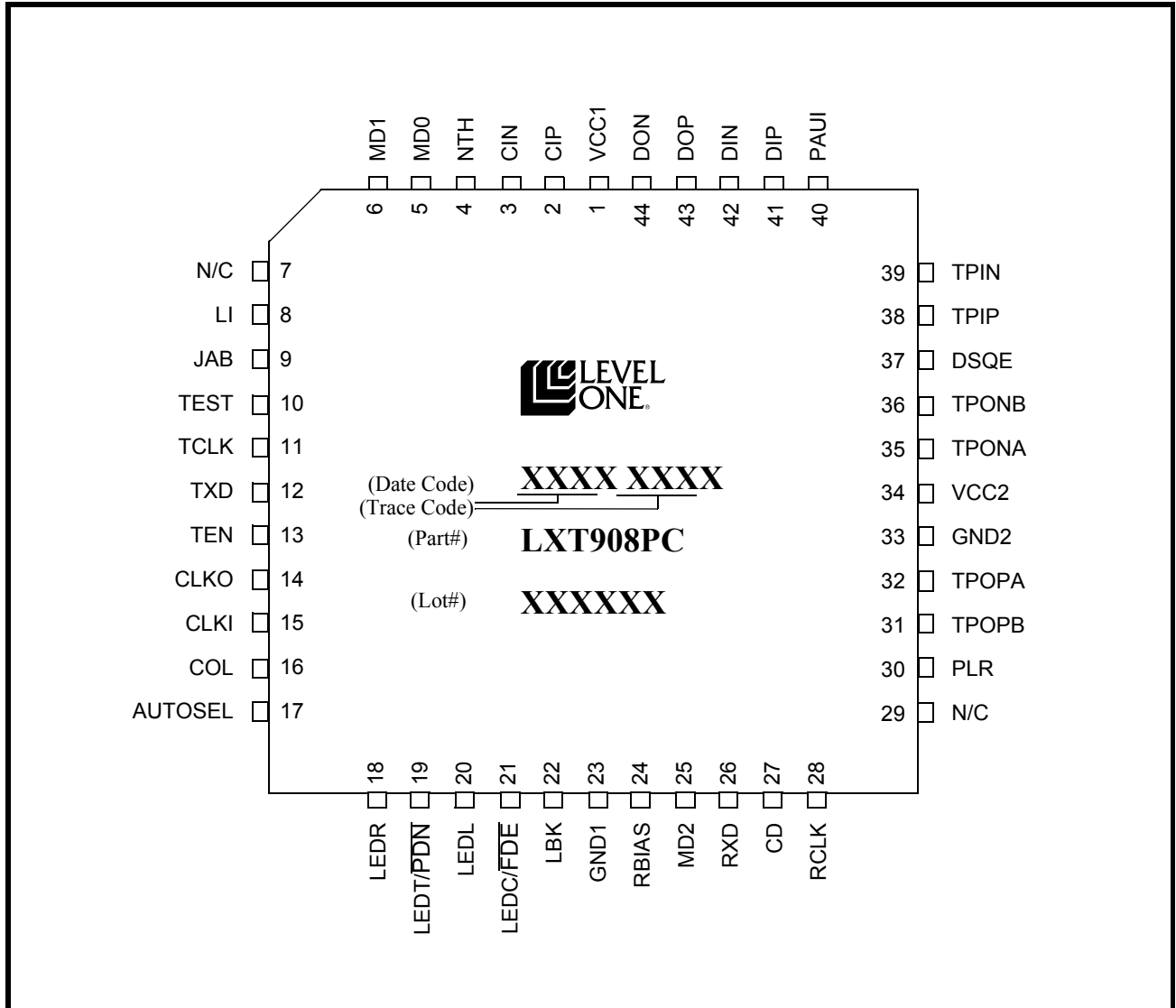

Table 1: LXT908 Signal Descriptions

| Pin # | Symbol | I/O | Description |
|--------------|-------------------|-------------|---|
| 1 34 | VCC1 VCC2 | - - | Power 1 and 2. Connect to positive power supply terminal (+3.3VDC or +5 VDC). |
| 2 3 | CIP CIN | I I | AUI Collision Pair. Differential input pair connected to the AUI transceiver CI circuit. The input is collision signaling or SQE. |
| 4 | NTH | I | Normal Threshold. When NTH is High, the normal TP squelch threshold is in effect. When NTH is Low, the normal TP squelch threshold is reduced by 4.5 dB. |
| 5 6 25 | MD0 MD1 MD2 | I I I | Mode Select 0 (MD0), Mode Select 1 (MD1) and Mode Select 2 (MD2). Mode select pins determine the controller compatibility mode as specified in Table 2. |
| 7 | N/C | - | No Connect. <i>This pin must be tied to ground or device damage may occur.</i> |
| 8 | LI | I | Link Test Enable. Controls Link Integrity Test; enabled when High, disabled when Low. |
| 9 | JAB | O | Jabber Indicator. Output goes High to indicate Jabber state. |
| 10 | TEST | I | Test. <i>This pin must be tied High.</i> |
| 11 | TCLK | O | Transmit Clock. A 10 MHz clock output. This clock signal should be directly connected to the transmit clock input of the controller. TCLK goes to high impedance (tri-state) when LEDT/PDN is pulled Low externally. |
| 12 | TXD | I | Transmit Data. Input signal containing NRZ data to be transmitted on the network. TXD is connected directly to the transmit data output of the controller. |
| 13 | TEN | I | Transmit Enable. Enables data transmission and starts the watchdog timer. Synchronous to TCLK (see Test Specifications for details). |
| 14 15 | CLKO CLKI | O I | Crystal Oscillator. A 20 MHz crystal must be connected across these pins, or a 20 MHz clock applied at CLKI with CLKO left open. |
| 16 | COL | O | Collision Detect. Output which drives the collision detect input of the controller. COL goes to high impedance (tri-state) when LEDT/PDN is pulled Low externally. |
| 17 | AUTOSEL | I | Automatic Port Select. When High, automatic port selection is enabled (the LXT908 defaults to the AUI port only if TP link integrity = Fail). When Low, manual port selection is enabled (the PAUI pin determines the active port). |
| 18 | LEDR | O | Receive LED. Open drain driver for the receive indicator LED. Output is pulled Low during receive, except when data is being looped back to DIN/DIP from a remote transceiver (external MAU). LED “On” time (i.e., Low output) is extended by approximately 100 ms. |
| 19 | LEDT/ PDN | O I | Transmit LED (LEDT)/Power Down (PDN). Open drain driver for the transmit indicator LED. Output is pulled Low during transmit. LED “On” time (i.e., Low output) is extended by approximately 100 ms. If externally tied Low, the LXT908 goes to power down state. In power down state, TCLK, COL, RXD, CD and RCLK (pins 11, 16, 26, 27 and 28, respectively) are tri-stated. |
| 20 | LEDL | O I | Link LED. Open drain driver for link integrity indicator LED. Output is pulled Low during link test pass. If externally tied Low, internal circuitry is forced to “Link Pass” state and the LXT908 will continue to transmit link test pulses. |

Table 1: LXT908 Signal Descriptions – continued

| Pin # | Symbol | I/O | Description |
|----------------------|----------------------------------|------------------|---|
| 21 | LEDC/ FDE | O I | Collision LED (LEDC)/Full Duplex Enable (FDE). Open drain driver for the collision indicator LED pulls Low during collision. LED “On” time (i.e., Low output) is extended by approximately 100 ms. If externally tied Low, the LXT908 disables the internal TP loopback and collision detection circuits to allow full duplex operation or external TP loopback. |
| 22 | LBK | I | Loopback. Enables internal loopback mode. Refer to Functional Description and Test Specifications for details. |
| 23 33 | GND1 GND2 | – – | Ground Returns 1 and 2. Connect to negative power supply terminal (ground). |
| 24 | RBIAS | I | Bias Control. A 12.4 kΩ 1% resistor to ground at this pin controls operating circuit bias. |
| 26 | RXD | O | Receive Data. Output signal connected directly to the receive data input of the controller. RXD goes to high impedance (tri-state) when LEDT/PDN is pulled Low externally. |
| 27 | CD | O | Carrier Detect. An output to notify the controller of activity on the network. CD goes to high impedance (tri-state) when LEDT/PDN is pulled Low externally. |
| 28 | RCLK | O | Receive Clock. A recovered 10 MHz clock which is synchronous to the received data and connected to the controller receive clock input. RCLK goes to high impedance (tri-state) when LEDT/PDN is pulled Low externally. |
| 29 | N/C | - | No Connect. <i>This pin must be tied to ground or device damage may occur.</i> |
| 30 | PLR | O | Polarity Reverse. Output goes High to indicate reversed polarity at the TP input. |
| 32 31 35 36 | TPOPA TPOPB TPONA TPONB | O O O O | Twisted-Pair Transmit Pairs A & B. Two differential driver pair outputs (A and B) to the twisted-pair cable. The outputs are pre-equalized. Each pair must be shorted together with an 11.5 Ω 1% resistor to match an impedance of 100Ω. |
| 37 | DSQE | I | Disable SQE. When DSQE is High, the SQE function is disabled. When DSQE is Low, the SQE function is enabled. SQE must be disabled for normal operation in Hub/Switch applications. |
| 38 39 | TPIP TPIN | I I | Twisted-Pair Receive Pair. A differential input pair from the TP cable. Receive filter is integrated on-chip. No external filters are required. |
| 40 | PAUI | I | Port/AUI Select. In Manual Port Select mode (AUTOSEL Low), PAUI selects the active port. When PAUI is High, the AUI port is selected. When PAUI is Low, the TP port is selected. In Auto Port Select mode, PAUI must be tied to ground. |
| 41 42 | DIP DIN | I I | AUI Receive Pair. Differential input pair from the AUI transceiver DI circuit. The input is Manchester encoded. |
| 43 44 | DOP DON | O O | AUI Transmit Pair. A differential output driver pair for the AUI transceiver cable. The output is Manchester encoded. |

FUNCTIONAL DESCRIPTION

Introduction

The LXT908 Universal Ethernet Interface Transceiver performs the physical layer signaling (PLS) and Media Attachment Unit (MAU) functions as defined by the IEEE 802.3 specification. It functions as an AUI (PLS-Only device) for use with 10BASE-2 or 10BASE-5 coaxial cable networks, or as an Integrated PLS/MAU for use with 10BASE-T twisted-pair networks. In addition to standard 10 Mbps operation, the LXT908 also supports full-duplex 20 Mbps operation.

The LXT908 interfaces a back end controller to either an AUI drop cable or a twisted-pair (TP) cable. The controller interface includes transmit and receive clock and NRZ data channels, as well as mode control logic and signaling. The AUI interface comprises three circuits: Data Output (DO), Data Input (DI) and Collision (CI). The twisted-pair interface comprises two circuits: Twisted-Pair Input (TPI) and Twisted-Pair Output (TPO). In addition to the three basic interfaces, the LXT908 contains an internal crystal oscillator and four LED drivers for visual status reporting.

Functions are defined from the back end controller side of the interface. The LXT908 Transmit function refers to data transmitted by the back end to the AUI cable (PLS-Only mode) or to the twisted-pair network (Integrated PLS/MAU mode). The LXT908 Receive function refers to data received by the back end from the AUI cable (PLS-Only) or from the twisted-pair network (Integrated PLS/MAU mode). In the integrated PLS/MAU mode, the LXT908 performs all required MAU functions defined by the IEEE 802.3 10BASE-T specification such as collision detection, link integrity testing, signal quality error messaging, jabber control and loopback. In the PLS-Only mode, the LXT908 receives incoming signals from the AUI DI circuit with ± 18 ns of jitter and drives the AUI DO circuit.

Controller Compatibility Modes

The LXT908 is compatible with most industry standard controllers including devices produced by Advanced Micro Devices (AMD), Motorola, Intel, Fujitsu, National Semiconductor, Seeq and Texas Instruments, as well as custom controllers. Five different control signal timing and polarity schemes (Modes 1 through 5) are required to achieve this compatibility. Mode select pins (MD2:0) determine Controller compatibility modes as listed in Table 2. Refer to Test Specifications for a complete set of timing diagrams for each mode.

Transmit Function

The LXT908 receives NRZ data from the controller at the TXD input as shown in the block diagram on the first page of this Data Sheet, and passes it through a Manchester encoder. The encoded data is then transferred to either the AUI cable (the DO circuit) or the twisted-pair network (the TPO circuit). The advanced integrated pulse shaping and filtering network produces the output signal on TPO and TPOP, shown in Figure 2. The TPO output is pre-distorted and pre-filtered to meet the 10BASE-T jitter template. An internal continuous resistor-capacitor filter is used to remove any high-frequency clocking noise from the pulse shaping circuitry. Integrated filters simplify the design work required for FCC-compliant EMI performance. During idle periods, the LXT908 transmits link integrity test pulses on the TPO circuit (if LI is enabled and integrated PLS/MAU mode is selected). External resistors control the termination impedance.

Figure 2: LXT908 TPO Output Waveform

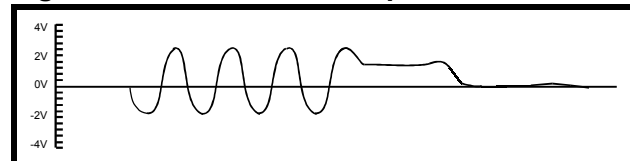

Table 2: Controller Compatibility Mode Options

| Controller Mode | MD2 | MD1 | MD0 |
|--|------|------|------|
| Mode 1 - For AMD AM7990, Motorola 68EN360, MPC860 or compatible controllers | Low | Low | Low |
| Mode 2 - For Intel 82596 or compatible controllers | Low | Low | High |
| Mode 3 - For Fujitsu MB86950, MB86960 or compatible controllers (Seeq 8005) ¹ | Low | High | Low |
| Mode 4 - For National Semiconductor 8390 or compatible controllers (TI TMS380C26) | Low | High | High |
| Mode 5 - For custom controllers (Mode 3 with TCLK, RCLK and COL inverted) | High | High | Low |

1. SEEQ controllers require inverters on CLKI, LBK, RCLK and COL in Mode 3; or on CLKI, LBK and TCLK in Mode 5.

Jabber Control Function

Figure 3 is a state diagram of the LXT908 Jabber control function. The LXT908 on-chip watchdog timer prevents the DTE from locking into a continuous transmit mode. When a transmission exceeds the time limit, the watchdog timer disables the transmit and loopback functions, and activates the JAB pin. Once the LXT908 is in the jabber state, the TXD circuit must remain idle for a period of 0.25 to 0.75 seconds before it will exit the jabber state.

Figure 3: Jabber Control Function

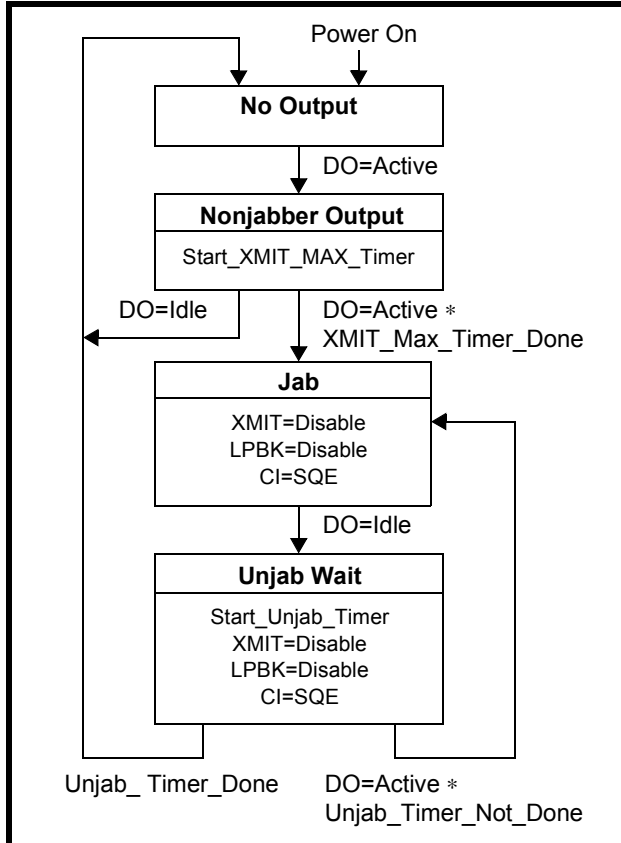

Receive Function

The LXT908 receive function acquires timing and data from the twisted-pair network (the TPI circuit) or from the AUI (the DI circuit). Valid received signals are passed through the on-chip filters and Manchester decoder then output as decoded NRZ data and recovered clock on the RXD and RCLK pins, respectively.

An internal RC filter and an intelligent squelch function discriminate noise from link test pulses and valid data streams. The receive function is activated only by valid

data streams above the squelch level and with proper timing. If the differential signal at the TPI or the DI circuit inputs falls below 75% of the threshold level (unsquelched) for 8 bit times (typical), the LXT908 receive function enters the idle state. If the polarity of the TPI circuit is reversed, LXT908 detects the polarity reverse and reports it via the PLR output. The LXT908 automatically corrects reversed polarity.

SQE Function

In the integrated PLS/MAU mode, the LXT908 supports the signal quality error (SQE) function as shown in Figure 4, although the SQE function can be disabled. After every successful transmission on the 10BASE-T network when SQE is enabled, the LXT908 transmits the SQE signal for $10BT \pm 5BT$ over the internal CI circuit which is indicated on the COL pin of the device. SQE must be disabled for normal operation in hub and switch applications. In twisted-pair applications, the SQE function is disabled when DSQE is set High, and enabled when DSQE is Low. When using the 10BASE-2 port of the LXT908, the SQE function is determined by the external MAU attached.

Figure 4: SQE Function

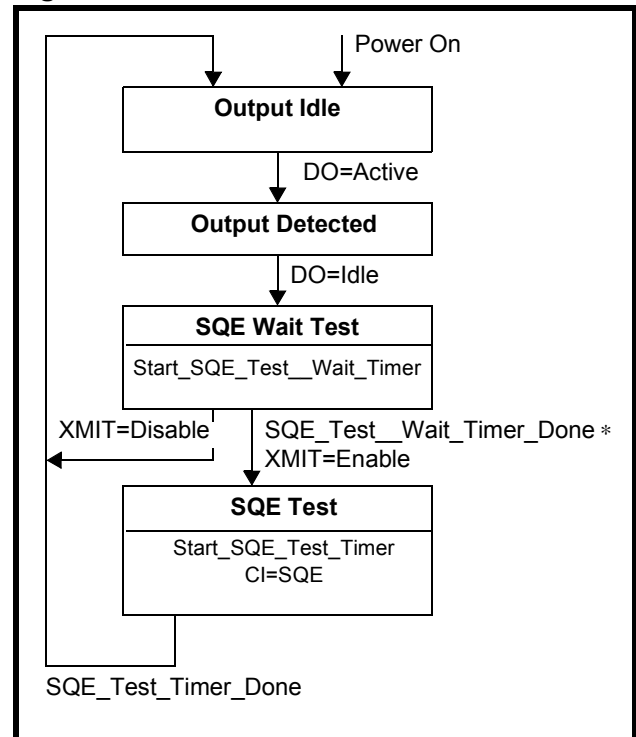

Polarity Reverse Function

The LXT908 polarity reverse function uses both link pulses and end-of-frame data to determine polarity of the received signal. A reversed polarity condition is detected when eight opposite receive link pulses are detected without receipt of a link pulse of the expected polarity. Reversed polarity is also detected if four frames are received with a reversed start-of-idle. Whenever a correct polarity frame or a correct link pulse is received, these two counters are reset to zero. If the LXT908 enters the link fail state and no valid data or link pulses are received within 96 to 128 ms, the polarity is reset to the default non-flipped condition. (If Link Integrity Testing is disabled, polarity detection is based only on received data.). Polarity correction is always enabled.

Loopback Function

The LXT908 provides the normal loopback function specified by the 10BASE-T standard for the twisted-pair port. The loopback function operates in conjunction with the transmit function. Data transmitted by the back-end is internally looped back within the LXT908 from the TXD pin through the Manchester encoder/decoder to the RXD pin and returned to the back-end. This “normal” loopback function is disabled when a data collision occurs, clearing the RXD circuit for the TPI data. Normal loopback is also disabled during link fail and jabber states.

The LXT908 also provides three additional loopback functions. An external loopback mode, useful for system-level testing, is controlled by pin 21 (LEDC). When LEDC is tied Low, the LXT908 disables the collision detection and internal loopback circuits, to allow external loopback or full-duplex operation.

“Normal” TP loopback is controlled by pin 22 (LBK). When the TP port is selected and LBK is High, TP loopback is “forced”, overriding collisions on the TP circuit. When LBK is Low, normal loopback is in effect.

AUI loopback is also controlled by the LBK pin. When the AUI port is selected and LBK is High, data transmitted by the back-end is internally looped back from the TXD pin through the Manchester encoder/decoder to the RXD pin. When LBK is Low, no AUI loopback occurs.

Collision Detection Function

The collision detection function operates on the twisted pair side of the interface. For standard (half-duplex) 10BASE-T operation, a collision is defined as the simultaneous presence of valid signals on both the TPI circuit and the TPO circuit. The LXT908 reports collisions to the back-end via the COL pin. If the TPI circuit becomes active while there is activity on the TPO circuit, the TPI data is passed to the back-end over the RXD circuit, disabling normal loopback. Figure 5 is a state diagram of the LXT908 collision detection function. Refer to Test Specifications for collision detection and COL/CI output timing (NOTE: For full-duplex operation, the collision detection circuitry must be disabled.)

Figure 5: Collision Detection Function

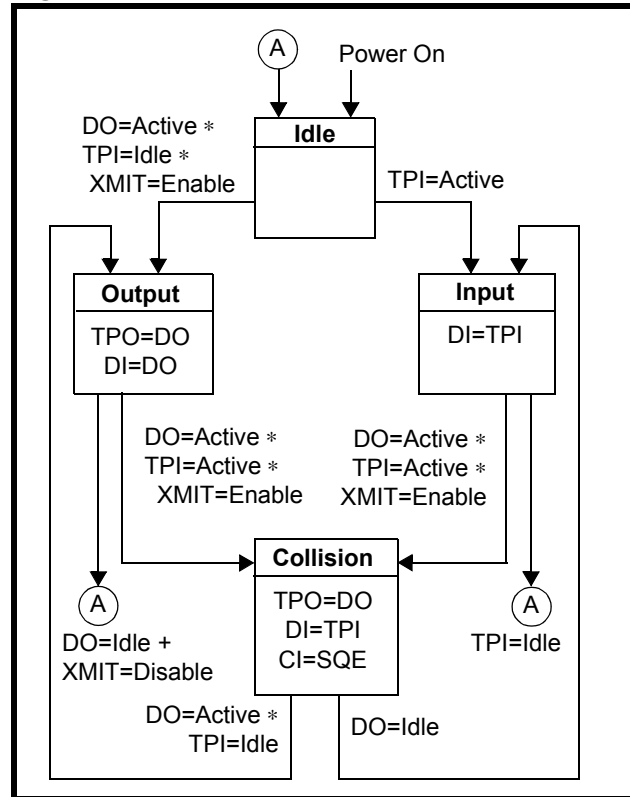

Link Pulse Transmission

The LXT908 transmits standard link pulses which meet the 10BASE-T specifications. Figure 6 shows the link integrity pulse timing.

Figure 6: Transmitted Link Integrity Pulse Timing

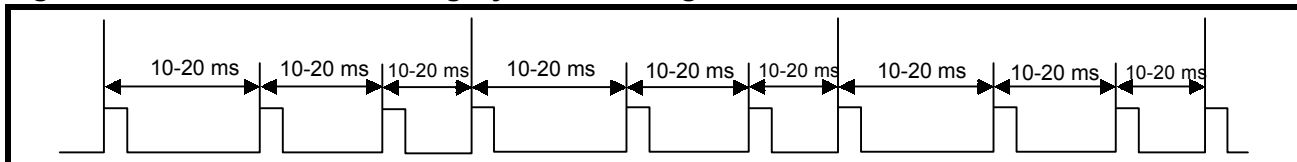

Link Integrity Test Function

Figure 7 is a state diagram of the LXT908 Link Integrity test function. The link integrity test is used to determine the status of the receive side twisted-pair cable. Link integrity testing is enabled when pin 8 (LI) is tied High. When enabled, the receiver recognizes link integrity pulses which are transmitted in the absence of receive traffic. If no

serial data stream or link integrity pulses are detected within 50 - 150ms, the chip enters a link fail state and disables the transmit and normal loopback functions. The LXT908 ignores any link integrity pulse with interval less than 2 - 7ms. The LXT908 will remain in the link fail state until it detects either a serial data packet or two or more link integrity pulses.

Figure 7: Link Integrity Test Function

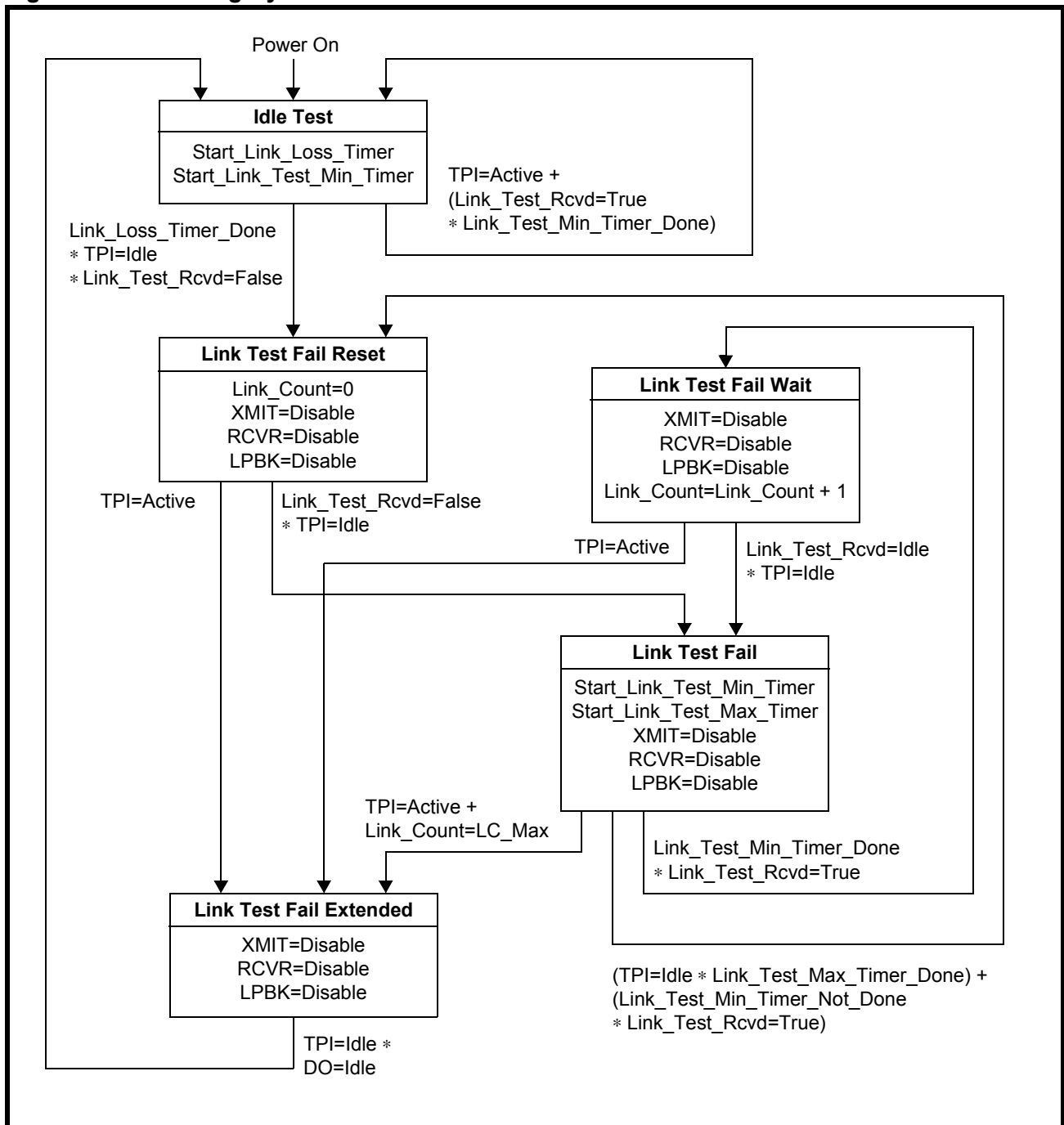

APPLICATION INFORMATION

Figures 8 through 14 show some typical LXT908 applications.

External Components

Crystal Information

Suitable crystals are available from various manufacturers. Table 3 lists some suitable crystals based on limited evaluation. Designers should test and validate all crystals before using them in production.

Table 3: Suitable Crystals

| Manufacturer | Part Number |
|--------------|-------------|
| MTRON | MP-1 |
| | MP-2 |

Magnetic Information

The LXT908 requires a 1:1 ratio for the receive transformer and a 1:2 ratio for the transmit transformer. Table 4 lists transformers suitable for the applications described in this data sheet. Designers should test and validate all magnetics before committing to a specific component.

Table 4: Suitable Magnetics

| Manufacturer | Part Number | |
|--------------|--------------|--------------|
| | Twisted-Pair | AUI |
| Belfuse | S553-5999-52 | S553-1006-AE |
| | S553-5999-86 | - |
| Fil-Mag | 23Z118 | 23Z90 |
| | 23Z118SM | 23Z90SM |
| Halo | TD74-1406Q | TD01-0756K |
| | TG74-1406N1 | TG01-0756N |
| Valor | PT4152 | LT6032 |
| | ST4152 | ST7032 |

Layout Requirements

Auto Port Select with External Loopback Control

Figure 8 is a typical LXT908 application. The diagram is arranged to group similar pins together; it does not represent the actual LXT908 pin-out. The controller interface pins (transmit data, clock and enable; receive data and clock; and the collision detect, carrier detect and loopback control pins) are shown at the top left.

Programmable option pins are grouped center left. The PAUI pin is tied Low and all other option pins are tied High. This set-up selects the following options:

- Automatic Port Selection (PAUI Low and AUTOSEL High)
- Normal Receive Threshold (NTH High)
- Mode 4, compatible with National NS8390 controllers (MD2:0 = Low, High, High)
- SQE Disabled (DSQE High)
- Link Testing Enabled (LI High)

Status outputs are grouped at lower left. Line status outputs drive LED indicators and the Jabber and Polarity status indicators are available as required.

Power and ground pins are shown at the bottom of the diagram. A single power supply is used for both VCC1 and VCC2 with a decoupling capacitor installed between the power and ground busses.

The TP and AUI interfaces are shown at upper and lower right, respectively. Impedance matching resistors for 100 UTP are installed in each I/O pair but no external filters are required.

Figure 8: LAN Adapter Board - Auto Port Select with External Loopback Control

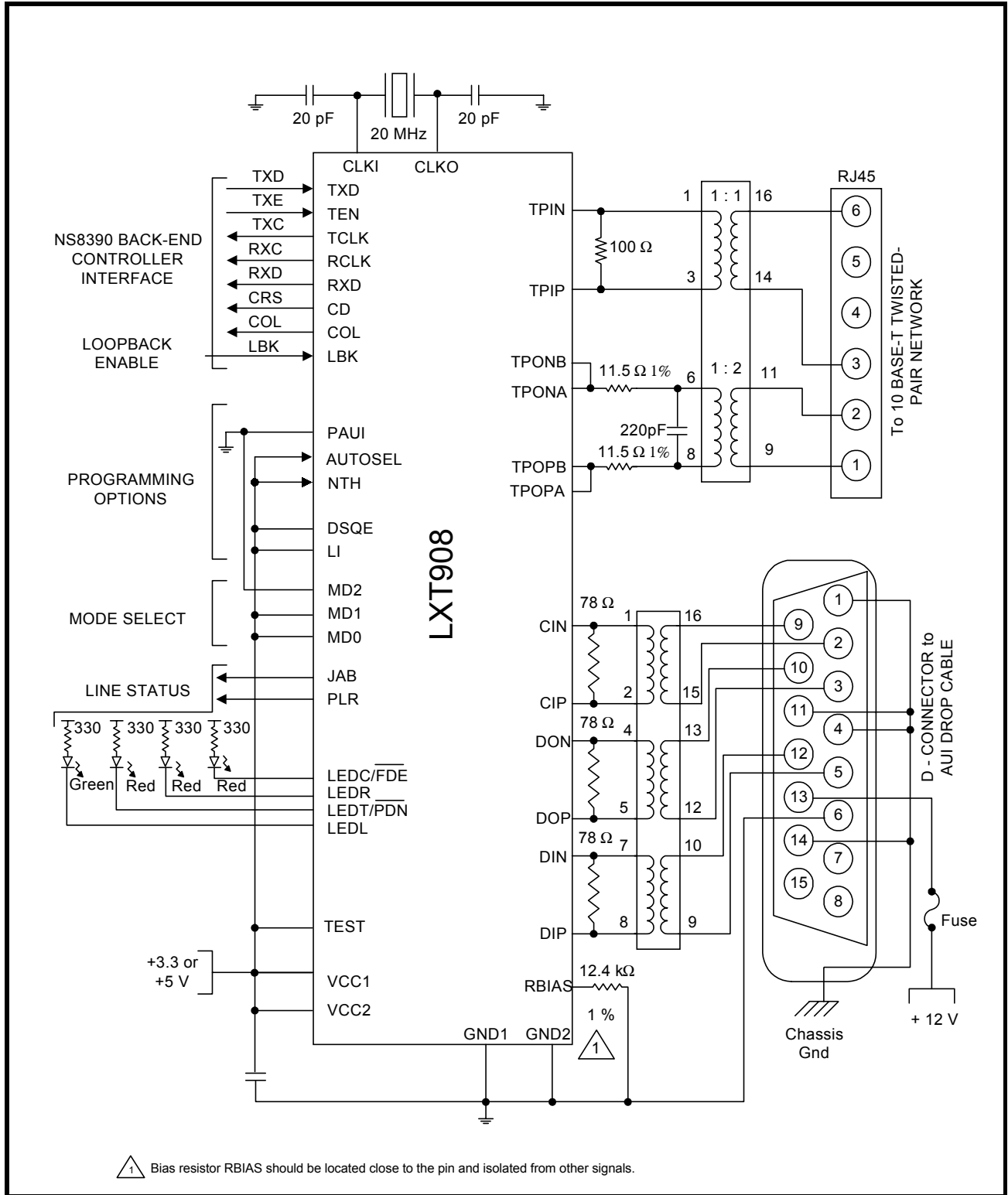

Dual Network Support-10Base T and Token Ring

Figure 10 shows the LXT908 with a Texas Instruments 380C26 CommProcessor. The 380C26 is compatible with Mode 4 (MD2:0 = Low, High, High). When used with the

380C26, both the LXT908 and a TMS38054 Token Ring transceiver can be tied to a single RJ45 allowing dual network support from a single connector. The LXT908 AUI port is not used.

Figure 10: LXT908/380C26 Interface for Dual Network Support of 10BASE-T and Token Ring

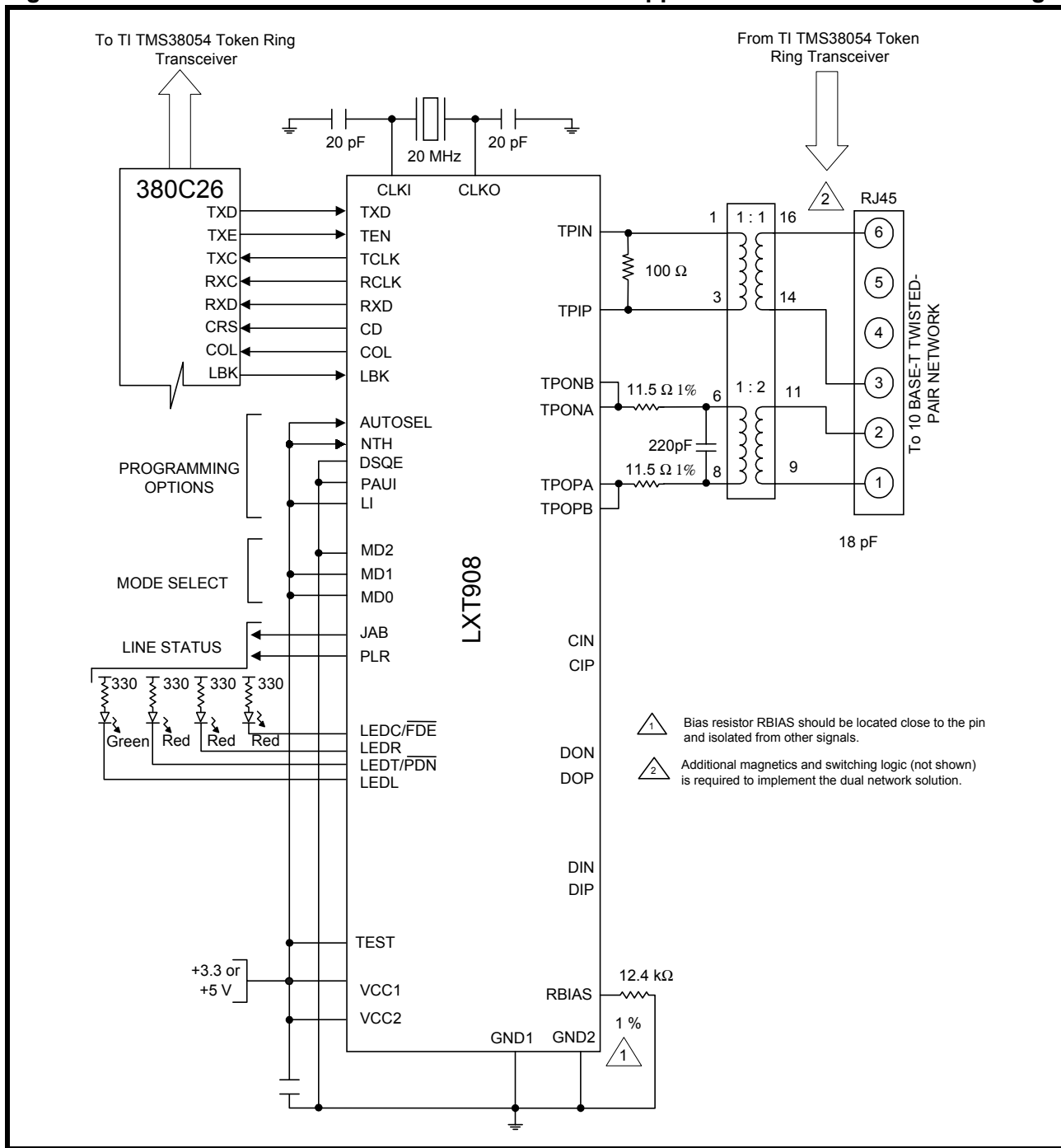

Manual Port Select & Link Test Function

With MD2:0 = Low, High, Low, the LXT908 logic and framing are set to Mode 3 (compatible with Fujitsu MB86950 and MB86960, and Seeq 8005 controllers). Figure 11 shows the setup for Fujitsu controllers. Figure 12 shows the four inverters required to interface with the Seeq

8005 controller. As in Figure 8, both these Mode 3 applications show the LI pin tied High, enabling Link Testing; and the NTH and DSQE pins are both tied High, selecting the standard receiver threshold and disabling SQE. However, in these applications AUTOSEL is tied Low, allowing external port selection through the PAUI pin.

Figure 11: LAN Adapter Board - Manual Port Select with Link Test Function

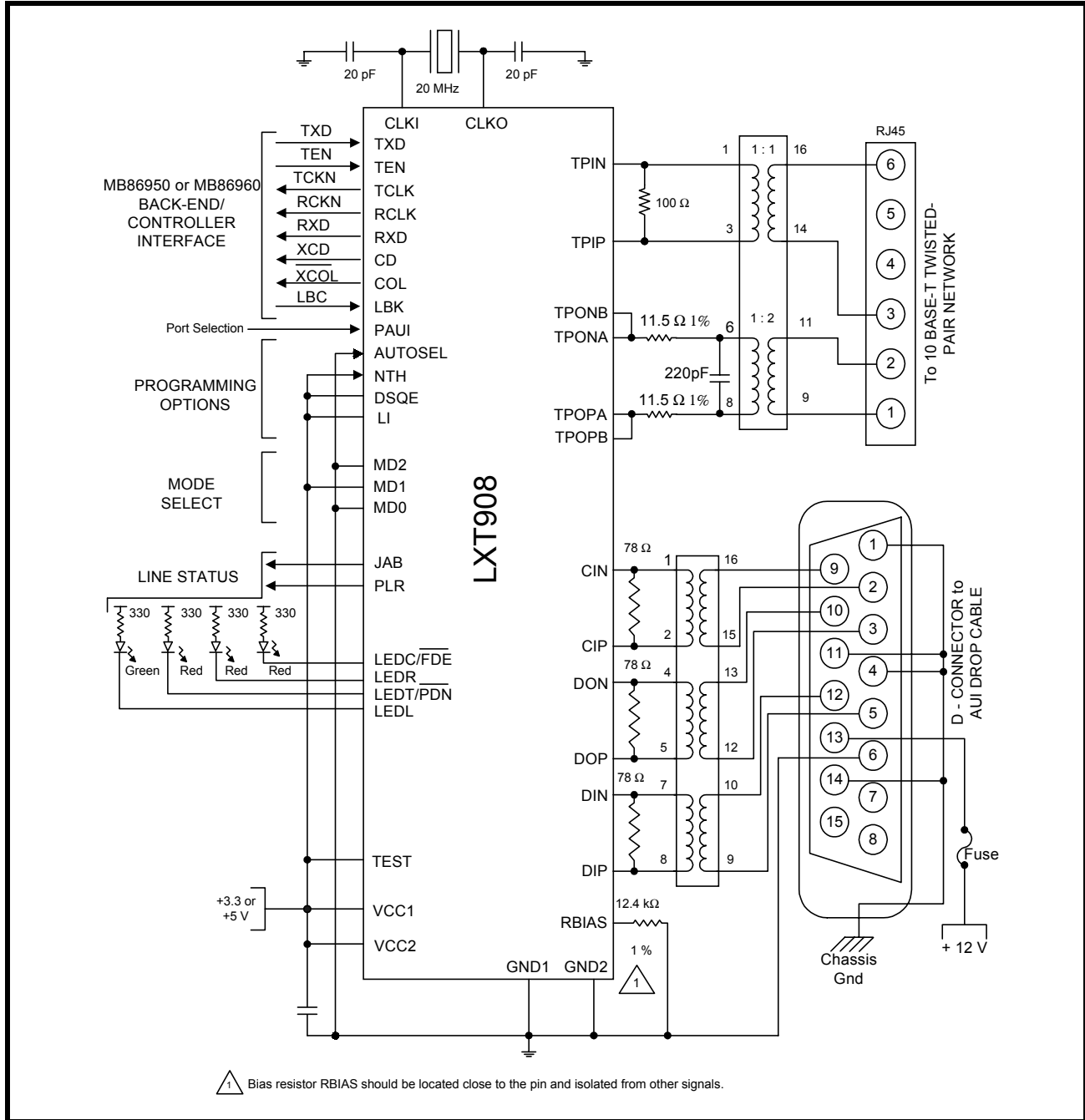
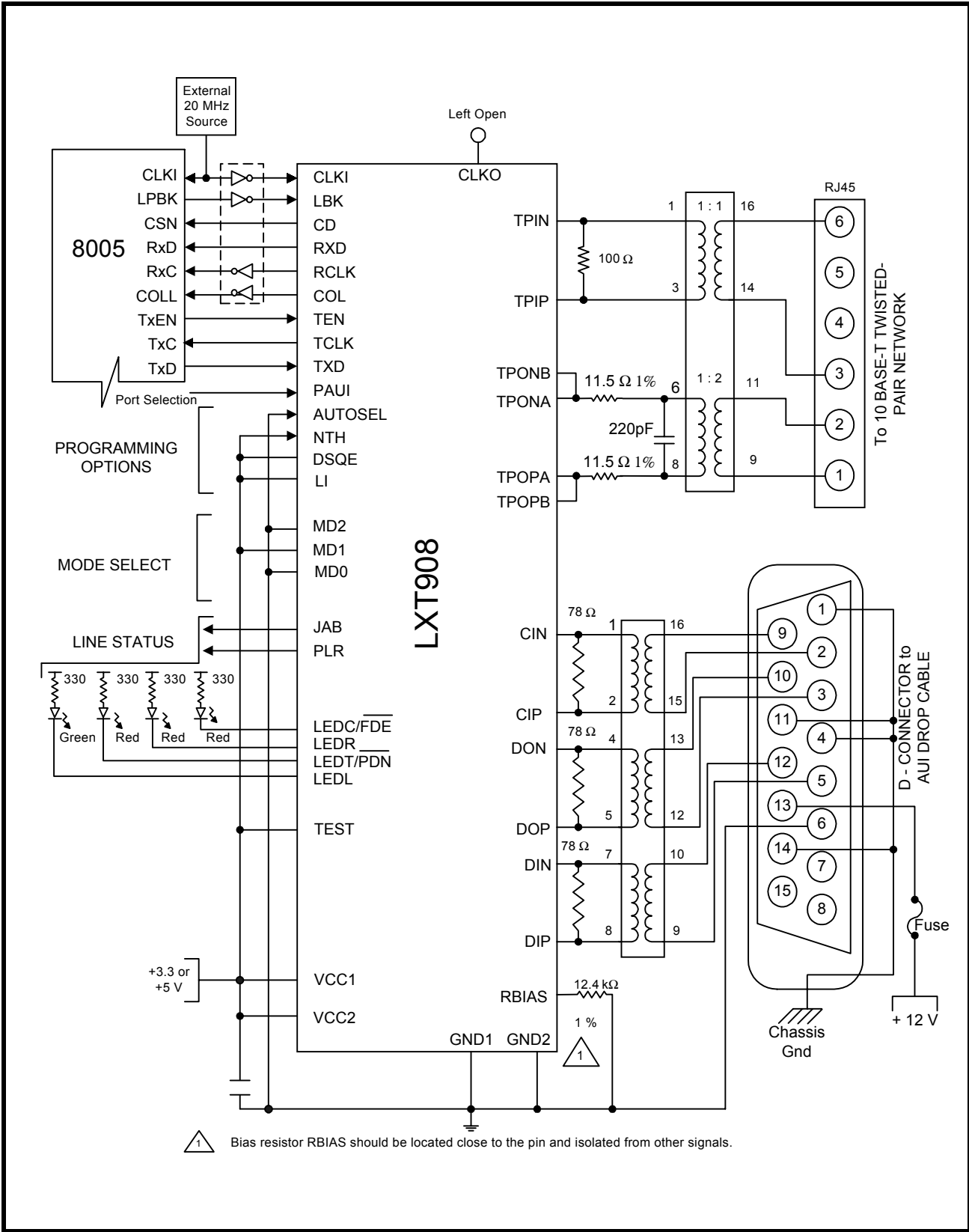

Figure 12: Manual Port Select with Seeq 8005 Controller



Three Media Application

Figure 13 shows the LXT908 in Mode 2 (compatible with Intel 82596 controllers) with additional media options for the AUI port. Two transformers are used to couple the AUI

port to either a D-connector or a BNC connector. (A DP8392 coax transceiver with PM6044 power supply are required to drive the thin coax network through the BNC.)

Figure 13: Three Media Application

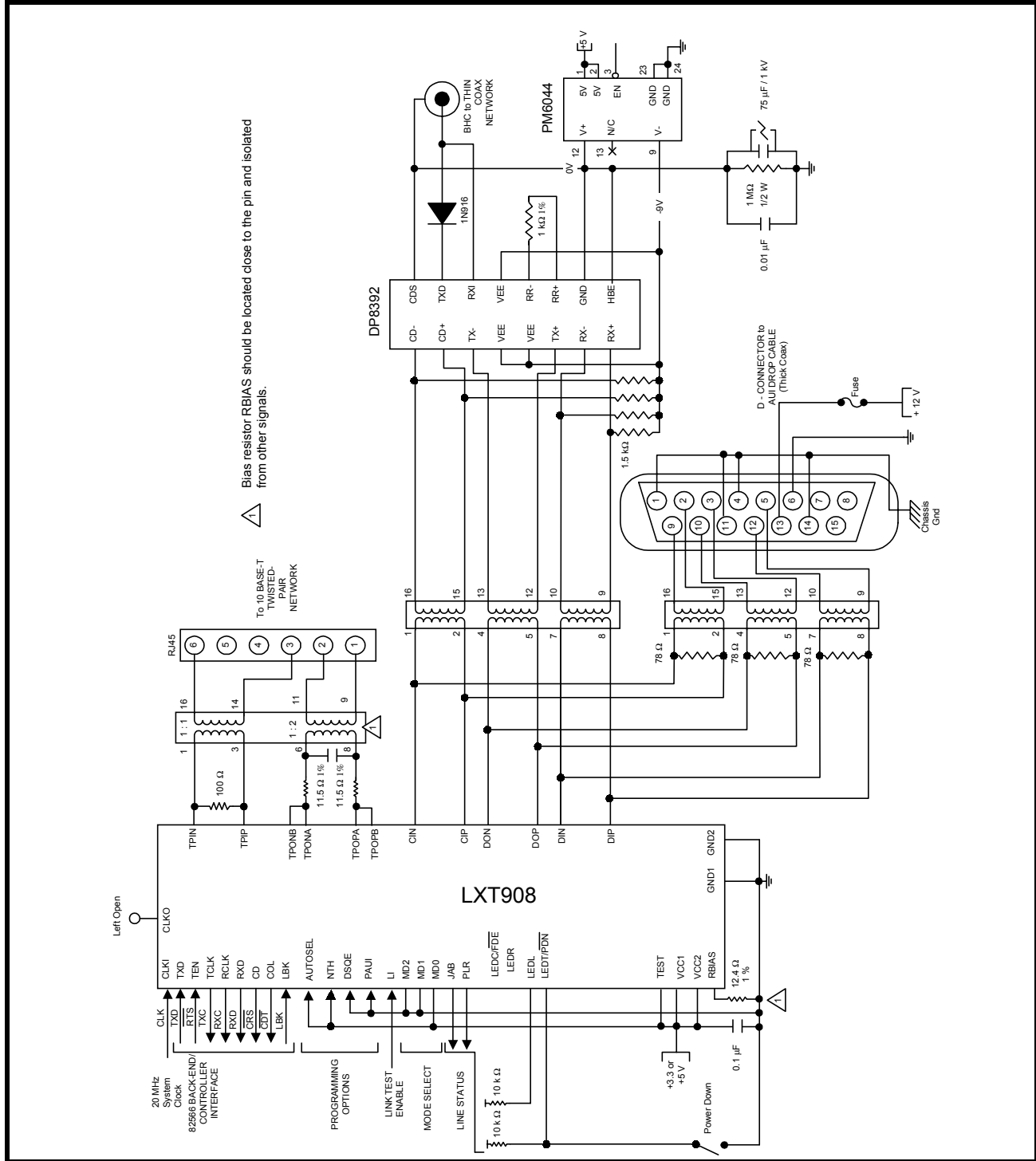

AUI Encoder/Decoder Only

In the application shown in Figure 14, the DTE is connected to a coaxial network through the AUI. AUTOSEL is tied Low and PAUI is tied High, manually selecting the AUI port. The twisted-pair port is not used. With MD2:0 all tied Low, the LXT908 logic and framing are set to Mode

1 (compatible with AMD and Motorola controllers). The LI pin is tied Low, disabling the link test function. The DSQE pin is also Low, enabling the SQE function. The LBK input controls loopback. A 20 MHz system clock is supplied at CLKI with CLKO left open.

Figure 14: AUI Encoder/Decoder Only Application

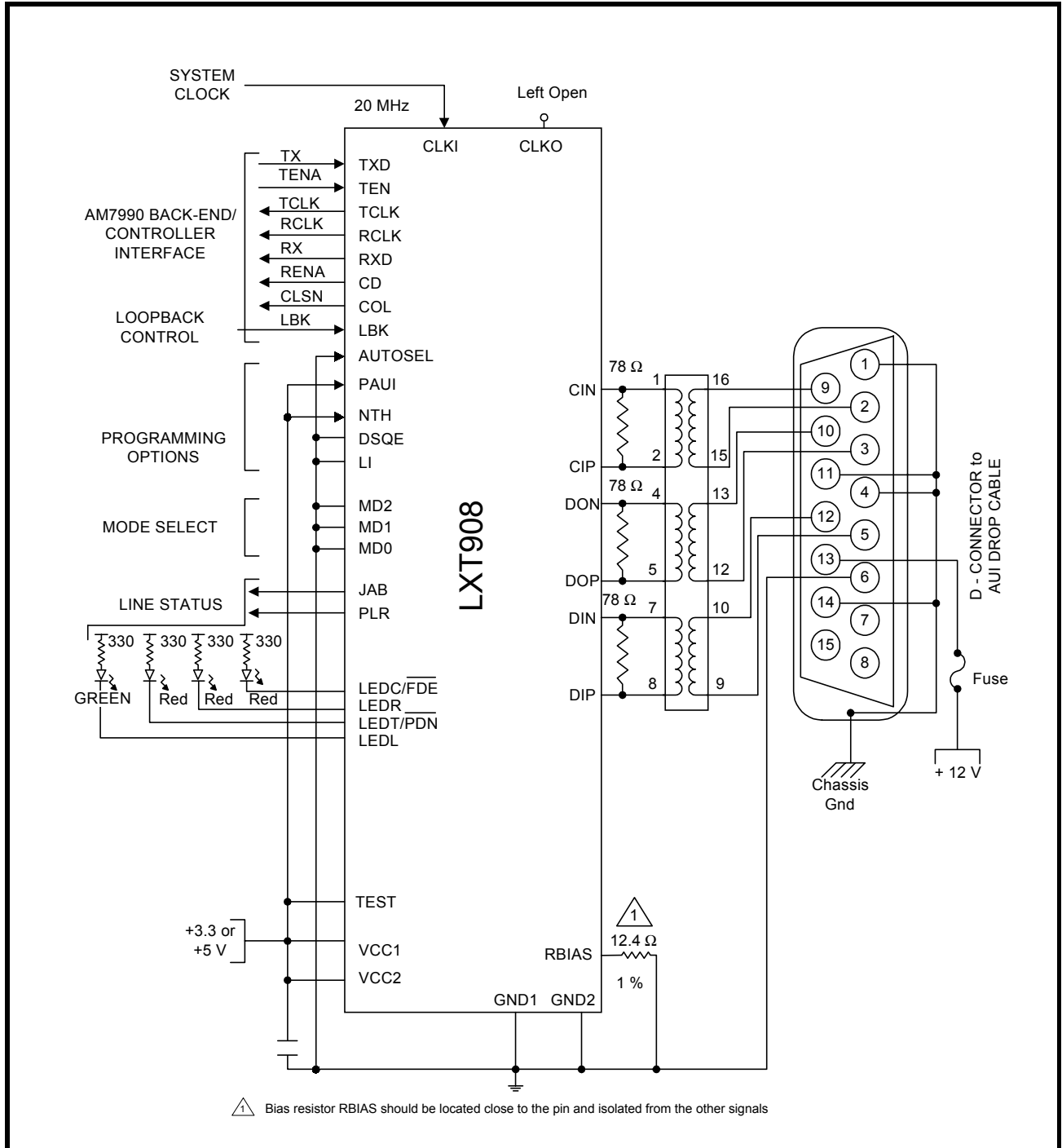

TEST SPECIFICATIONS

NOTE

The minimum and maximum values in Tables 5 through 14 and Figures 15 through 44 represent the performance specifications of the LXT908 and are guaranteed by test, except where noted by design.

Table 5: Absolute Maximum Values

| Parameter | Symbol | Min | Max | Units |
|-------------------------------|--------|------|------|-------|
| Supply voltage | VCC | -0.3 | 6 | V |
| Ambient operating temperature | TA | 0 | 70 | °C |
| Storage temperature | TSTG | -65 | +150 | °C |

CAUTION

Exceeding these values may cause permanent damage. Functional operation under these conditions is not implied. Exposure to maximum rating conditions for extended periods may affect device reliability.

Table 6: Recommended Operating Conditions

| Parameter | Symbol | Min | Typ | Max | Units | Test Conditions |
|---|--------|-------|-----|------|-------|-----------------|
| Recommended supply voltage ¹ | VCC | 3.135 | 5.0 | 5.25 | V | |
| Recommended operating temperature | TOP | 0 | – | 70 | °C | |

1. Voltages with respect to ground unless otherwise specified.

Table 7: I/O Electrical Characteristics (Over Recommended Range)

| Parameter | Sym | Min | Typ ¹ | Max | Units | Test Conditions | |
|--|------|-----|------------------|-----|-------|-----------------|---------------|
| Input Low voltage ² | VIL | – | – | 0.8 | V | | |
| Input High voltage ² | VIH | 2.0 | – | – | V | | |
| Output Low voltage | VOL | – | – | 0.4 | V | IOL = 1.6 mA | |
| | VOL | – | – | 10 | %VCC | IOL < 10 µA | |
| Output Low voltage (Open drain LED driver) | VOLL | – | – | 0.7 | V | IOLL = 10 mA | |
| Output High voltage | VOH | 2.4 | – | – | V | IOH = 40 µA | |
| | VOH | 90 | – | – | %VCC | IOH < 10 µA | |
| Output rise time TCLK & RCLK | CMOS | – | – | 3 | 12 | ns | CLOAD = 20 pF |
| | TTL | – | – | 2 | 8 | ns | |
| Output fall time TCLK & RCLK | CMOS | – | – | 3 | 12 | ns | CLOAD = 20 pF |
| | TTL | – | – | 2 | 8 | ns | |

1. Typical values are at 25 °C and are for design aid only; not guaranteed and not subject to production testing.
2. Limited functional tests are performed at these input levels. The majority of functional tests are performed at levels of 0V and 3V.

Table 7: I/O Electrical Characteristics (Over Recommended Range) – continued

| Parameter | Sym | Min | Typ ¹ | Max | Units | Test Conditions | |
|-------------------------------------|-----------------|-----|------------------|-------|-------|-----------------|---------------------|
| CLKI rise time (externally driven) | – | – | – | 10 | ns | | |
| CLKI duty cycle (externally driven) | – | – | | 40/60 | % | | |
| Supply current | Normal Mode | ICC | – | 65 | 85 | mA | Idle Mode |
| | | ICC | – | 95 | 120 | mA | Transmitting on TP |
| | | ICC | – | 90 | 120 | mA | Transmitting on AUI |
| | Power Down Mode | ICC | – | 0.75 | 2 | mA | |

1. Typical values are at 25 °C and are for design aid only; not guaranteed and not subject to production testing.
 2. Limited functional tests are performed at these input levels. The majority of functional tests are performed at levels of 0V and 3V.

Table 8: AUI Electrical Characteristics (Over Recommended Range)

| Parameter | Symbol | Min | Typ ¹ | Max | Units | Test Conditions |
|--------------------------------|--------|------|------------------|-------|-------|-------------------------|
| Input Low current | IIL | – | – | -700 | µA | |
| Input High current | IIH | – | – | 500 | µA | |
| Differential output voltage | VOD | ±550 | – | ±1200 | mV | |
| Differential squelch threshold | VDS | 150 | 260 | 350 | mV | 5 MHz square wave input |

1. Typical values are at 25 °C and are for design aid only; not guaranteed and not subject to production testing.

Table 9: Twisted-Pair Electrical Characteristics (Over Recommended Range)

| Parameter | Symbol | Min | Typ ¹ | Max | Units | Test Conditions | |
|--|--------------------------------|-----|------------------|------|-------|--|-------------------------|
| Transmit output impedance | ZOUT | – | 5 | – | Ω | | |
| Transmit timing jitter addition ² | – | – | ±6.4 | ±10 | ns | 0 line length for internal MAU | |
| Transmit timing jitter added by the MAU and PLS sections ^{2, 3} | – | – | ±3.5 | ±5.5 | ns | After line model specified by IEEE 802.3 for 10BASE-T internal MAU | |
| Receive input impedance | ZIN | – | 20 | – | kΩ | Between TPIP/TPIN, CIP/CIN & DIP/DIN | |
| Differential Squelch Threshold | Normal Threshold NTH = High | VDS | 300 | 395 | 585 | mV | 5 MHz square wave input |
| | Reduced Threshold NTH = Low | VDS | 180 | 250 | 345 | mV | 5 MHz square wave input |

1. Typical values are at 25 °C and are for design aid only; not guaranteed and not subject to production testing.
 2. Parameter is guaranteed by design; not subject to production testing.
 3. IEEE 802.3 specifies maximum jitter additions at 1.5 ns for the AUI cable, 0.5 ns from the encoder, and 3.5 ns from the MAU.

Table 10: Switching Characteristics (Over Recommended Range)

| Parameter | | Symbol | Minimum | Typical ¹ | Maximum | Units |
|-----------------------|------------------------|--------|---------|----------------------|---------|-------|
| Jabber Timing | Maximum transmit time | – | 20 | – | 150 | ms |
| | Unjab time | – | 250 | – | 750 | ms |
| Link Integrity Timing | Time link loss receive | – | 50 | – | 150 | ms |
| | Link min receive | – | 2 | – | 7 | ms |
| | Link max receive | – | 50 | – | 150 | ms |
| | Link transmit period | – | 8 | 10/20 | 24 | ms |

1. Typical values are at 25 °C and are for design aid only; not guaranteed and not subject to production testing.

Table 11: RCLK/Start-of-Frame Timing (Over Recommended Range)

| Parameter | | Symbol | Minimum | Typical ¹ | Maximum | Units |
|--|-------------------|--------|---------|----------------------|---------|-------|
| Decoder acquisition time | AUI | tDATA | – | 900 | 1100 | ns |
| | TP | tDATA | – | 1200 | 1500 | ns |
| CD turn-on delay | AUI | tCD | – | 25 | 200 | ns |
| | TP | tCD | – | 420 | 550 | ns |
| Receive data setup from RCLK | Mode 1 | trDS | 60 | 70 | – | ns |
| | Modes 2 through 5 | trDS | 30 | 45 | – | ns |
| Receive data hold from RCLK | Mode 1 | trDH | 10 | 20 | – | ns |
| | Modes 2 through 5 | trDH | 30 | 45 | – | ns |
| RCLK shut off delay from CD assert (Mode 3 and Mode 5) | | tsws | – | ±100 | – | ns |

1. Typical values are at 25° C and are for design aid only; not guaranteed and not subject to production testing.

Table 12: RCLK/End-of-Frame Timing (Over Recommended Range)

| Parameter | Type | Sym | Mode 1 | Mode 2 | Mode 3 | Mode 4 | Mode 5 | Units |
|--|------------------|--------|--------|--------|----------|--------|----------|-------|
| RCLK after CD off | Min | tRC | 5 | 1 | – | 5 | – | BT |
| RXD throughput delay | Max | tRD | 400 | 375 | 375 | 375 | 375 | ns |
| CD turn off delay ² | Max | tCDOFF | 500 | 475 | 475 | 475 | 475 | ns |
| Receive block out after TEN off | Typ ¹ | tIFG | 5 | 50 | – | – | – | BT |
| RCLK switching delay after CD off (Mode 3 and 5) | Typ ¹ | tsWE | – | – | 120(±80) | – | 120(±80) | ns |

1. Typical values are at 25° C and are for design aid only; not guaranteed and not subject to production testing.

2. CD turn-off delay measured from middle of last bit; timing specification is unaffected by the value of the last bit.

Table 13: Transmit Timing (Over Recommended Range)

| Parameter | Symbol | Minimum | Typical ¹ | Maximum | Units |
|----------------------------------|--------|---------|----------------------|---------|-------|
| TEN setup from TCLK | tEHCH | 22 | – | – | ns |
| TXD setup from TCLK | tDSCH | 22 | – | – | ns |
| TEN hold after TCLK | tCHEL | 5 | – | – | ns |
| TXD hold after TCLK | tCHDU | 5 | – | – | ns |
| Transmit start-up delay - AUI | tSTUD | – | 220 | 450 | ns |
| Transmit start-up delay - TP | tSTUD | – | 430 | 450 | ns |
| Transmit through-put delay - AUI | tTPD | – | – | 300 | ns |
| Transmit through-put delay - TP | tTPD | – | 305 | 350 | ns |

1. Typical values are at 25° C and are for design aid only; not guaranteed and not subject to production testing.

Table 14: Collision, COL/CI Output and Loopback Timing (Over Recommended Range)

| Parameter | Symbol | Minimum | Typical ¹ | Maximum | Units |
|-------------------------------|---------|---------|----------------------|---------|-------|
| COL turn-on delay | tCOLD | – | 40 | 500 | ns |
| COL turn-off delay | tCOLOFF | – | 420 | 500 | ns |
| COL (SQE) Delay after TEN off | tSQED | 0.65 | 1.2 | 1.6 | μs |
| COL (SQE) Pulse Duration | tSQEP | 500 | 1000 | 1500 | ns |
| LBK setup from TEN | tKHEH | 10 | 25 | – | ns |
| LBK hold after TEN | tKHEL | 10 | 0 | – | ns |

1. Typical values are at 25° C and are for design aid only; not guaranteed and not subject to production testing.

Timing Diagrams for Mode 1 (MD2, 1, 0 = Low, Low, Low) Figures 15 through 20

Figure 15: Mode 1 RCLK/Start-of-Frame Timing

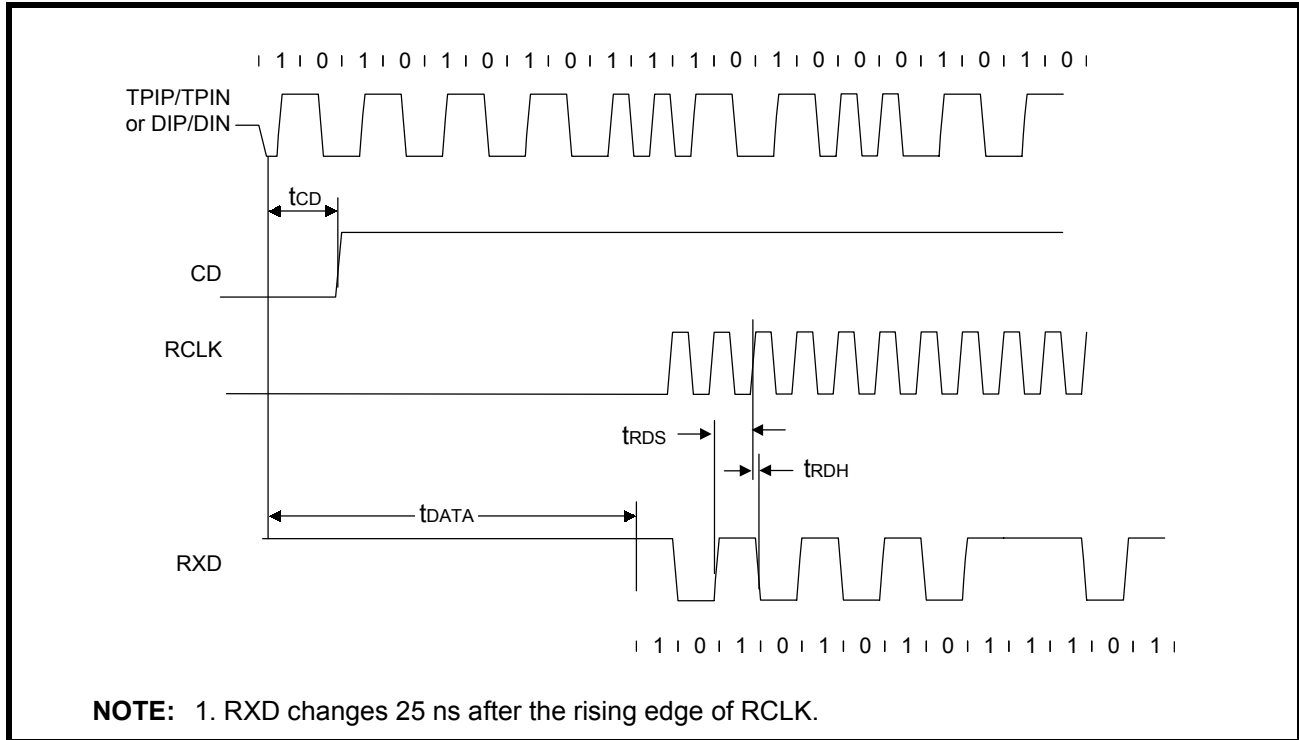

Figure 16: Mode 1 RCLK/End-of-Frame Timing

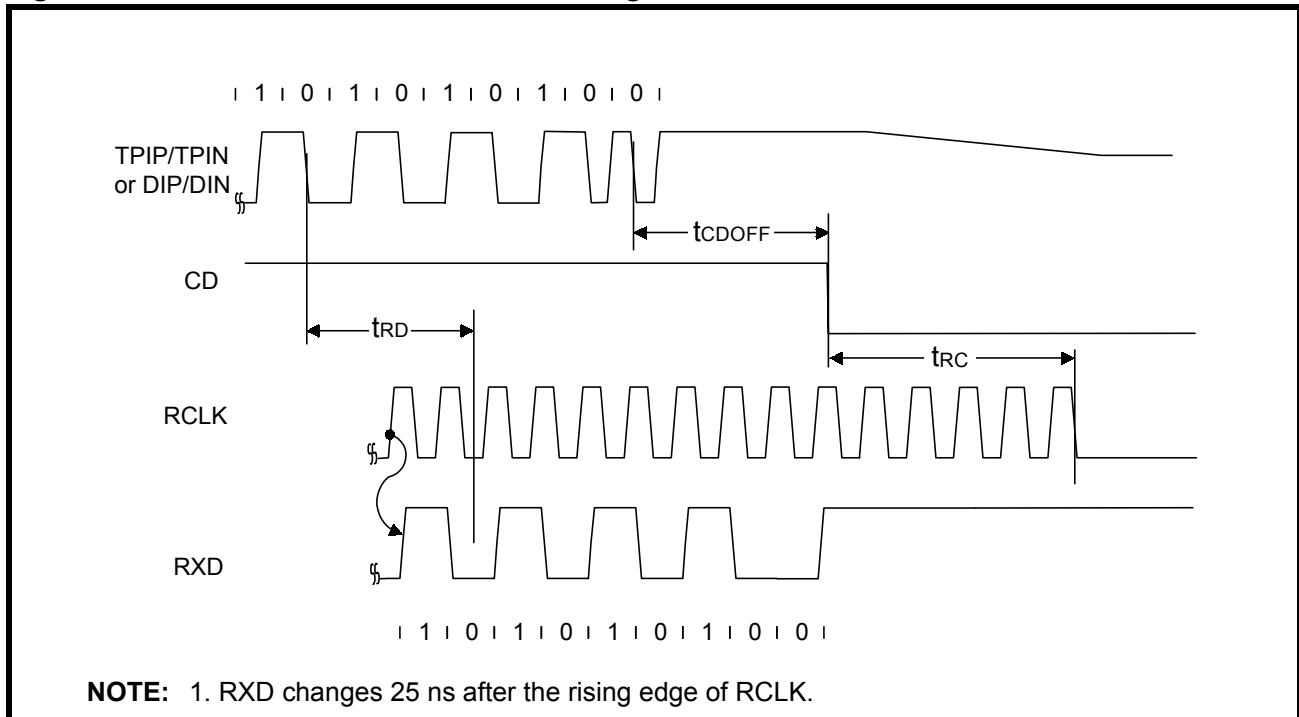

Figure 17: Mode 1 Transmit Timing

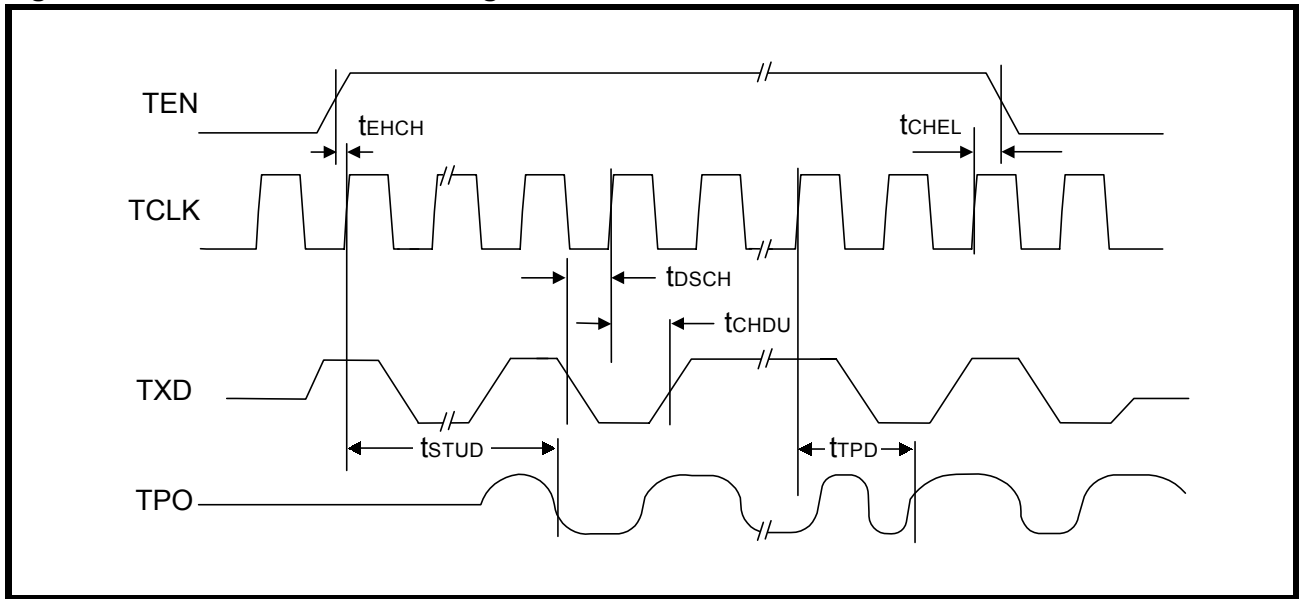

Figure 18: Mode 1 Collision Detect Timing

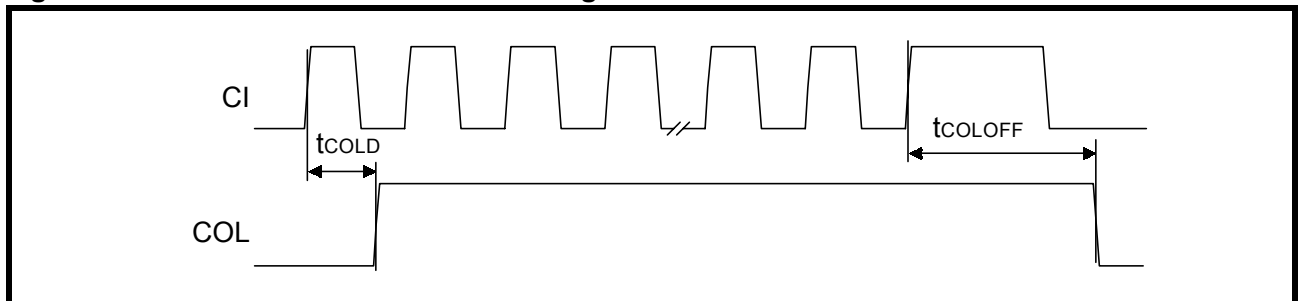

Figure 19: Mode 1 COL/SQE Output Timing/CI Output Timing

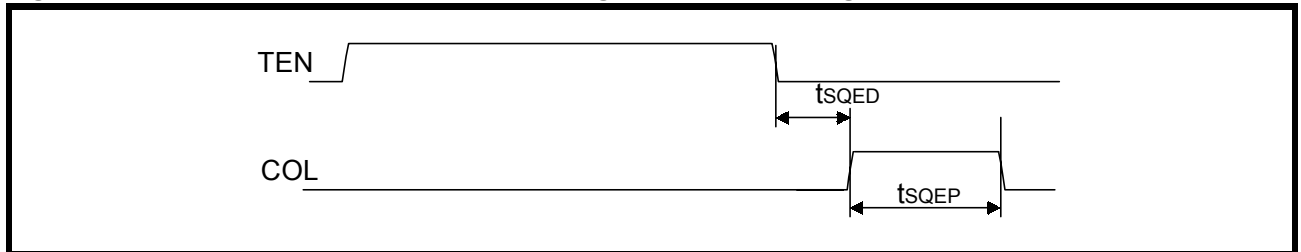
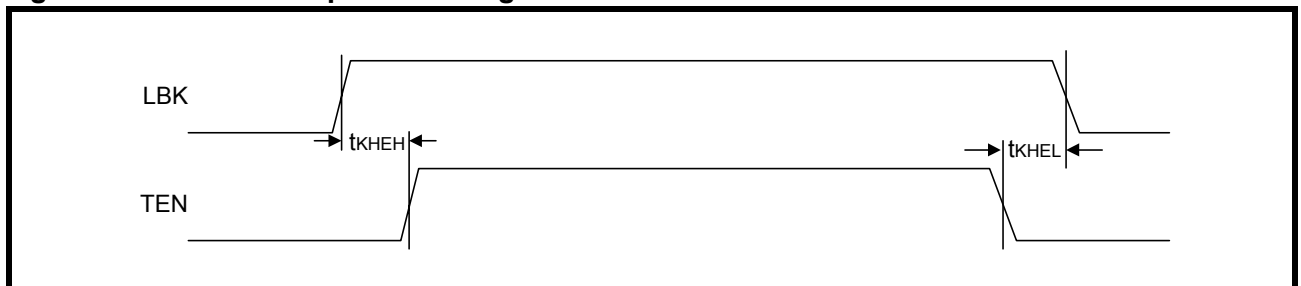

Figure 20: Mode 1 Loopback Timing



Timing Diagrams for Mode 2 (MD2, 1, 0 = Low, Low, High) Figures 21 through 26

Figure 21: Mode 2 RCLK/Start-of-Frame Timing

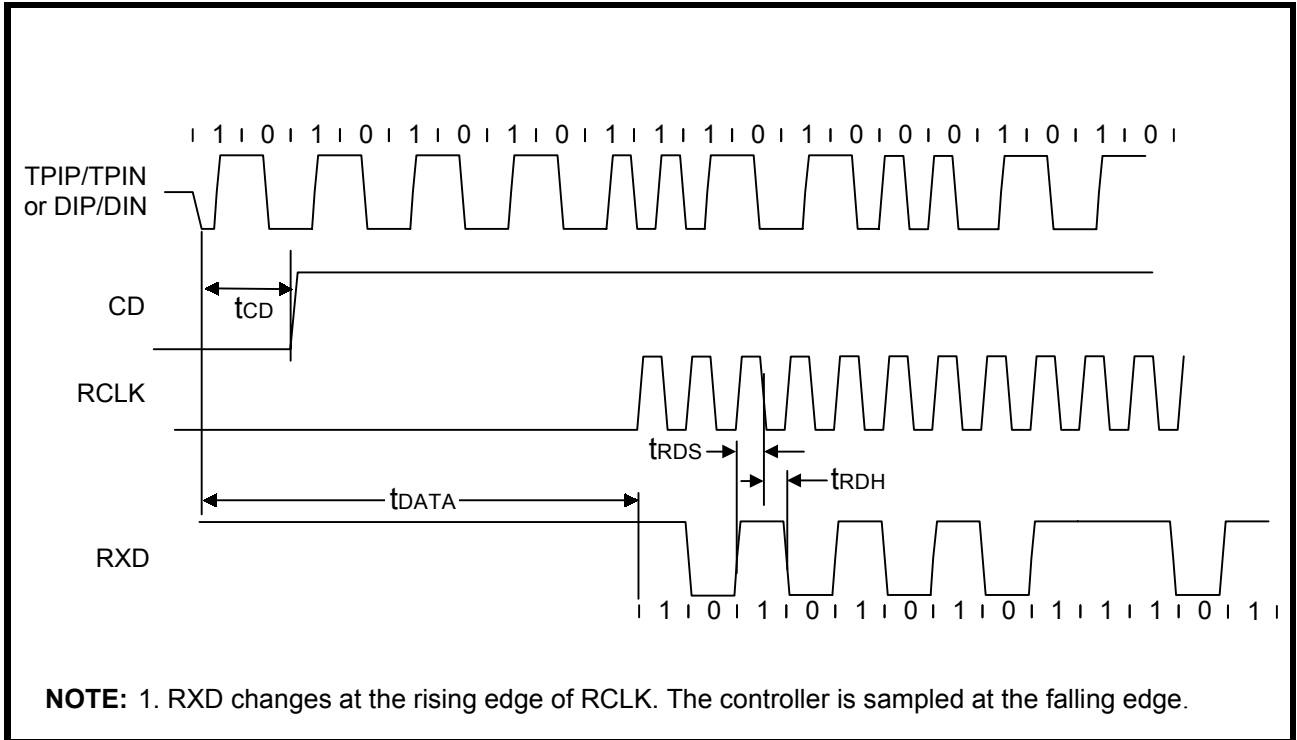

Figure 22: Mode 2 RCLK/End-of-Frame Timing

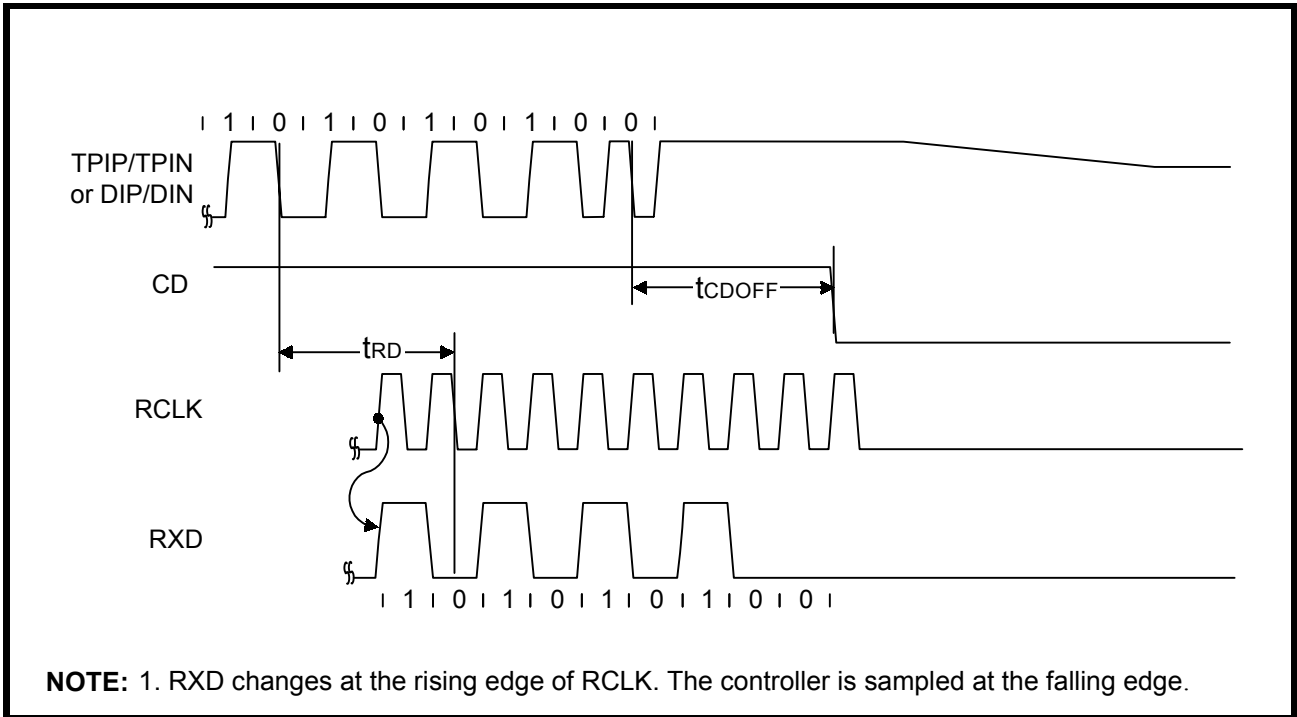

Figure 23: Mode 2 Transmit Timing

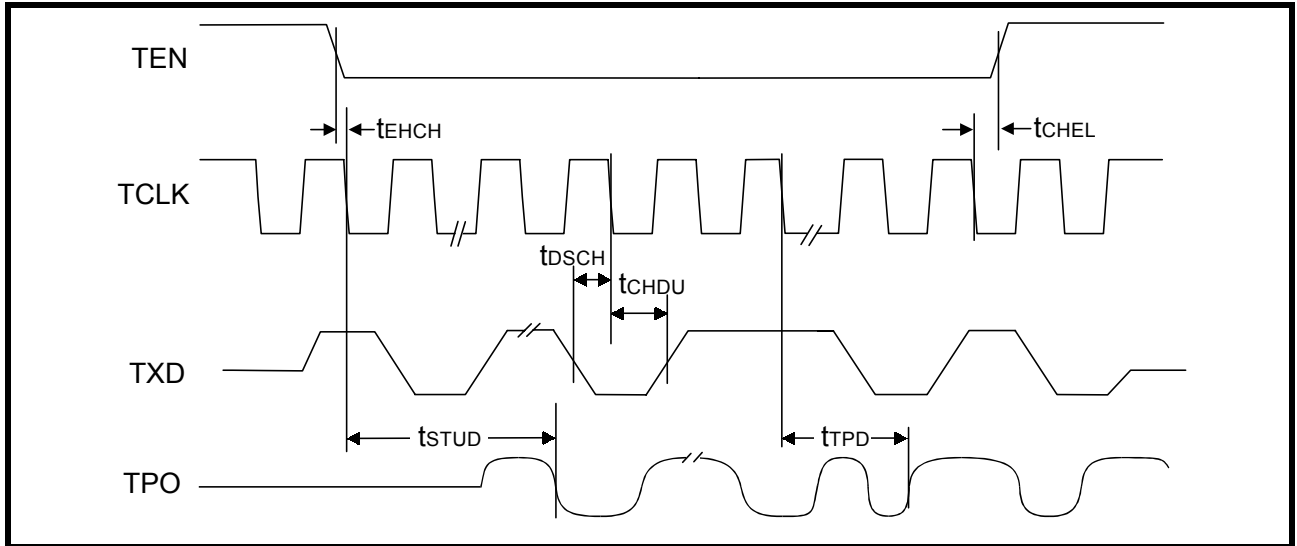

Figure 24: Mode 2 Collision Detect Timing

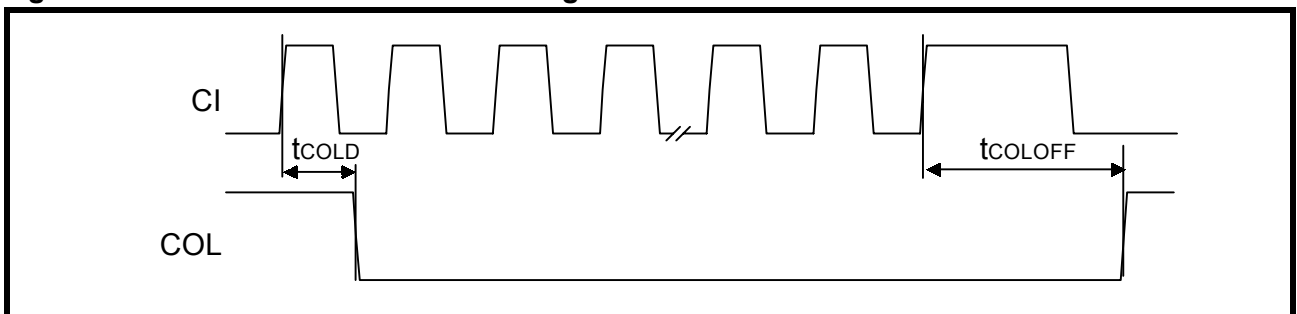

Figure 25: Mode 2 COL/SQE Output Timing

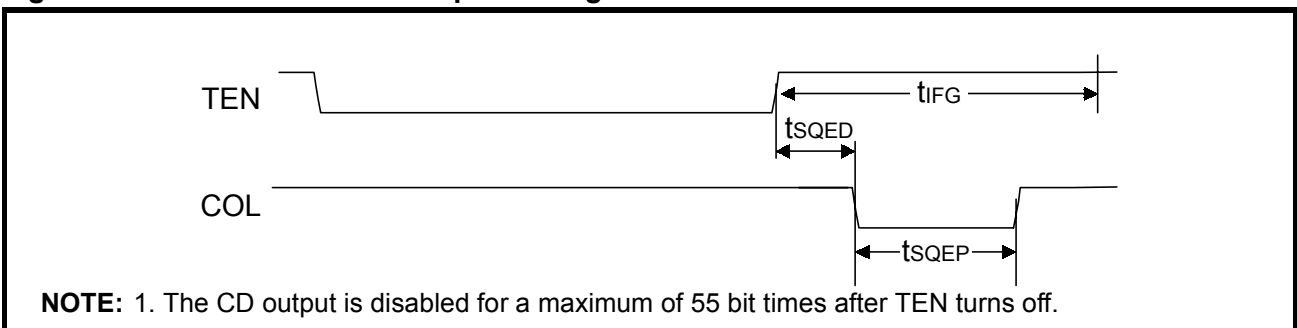
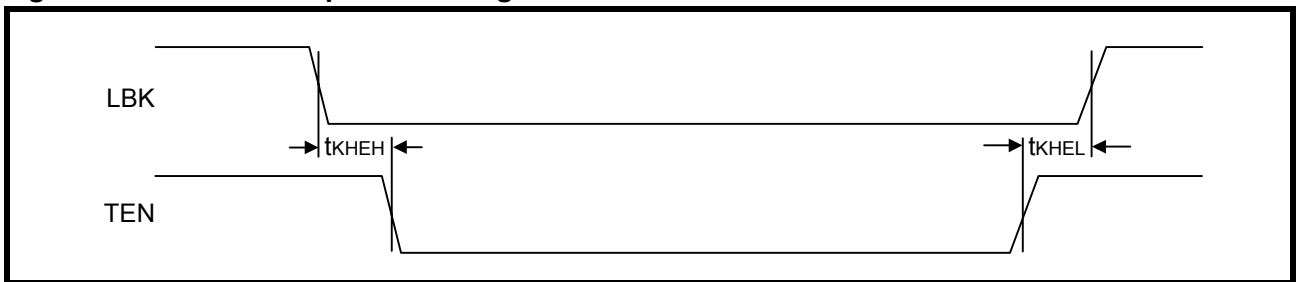

Figure 26: Mode 2 Loopback Timing



Timing Diagrams for Mode 3 (MD2, 1, 0 = Low, High, Low) Figures 27 through 32

Figure 27: Mode 3 RCLK/Start-of-Frame Timing

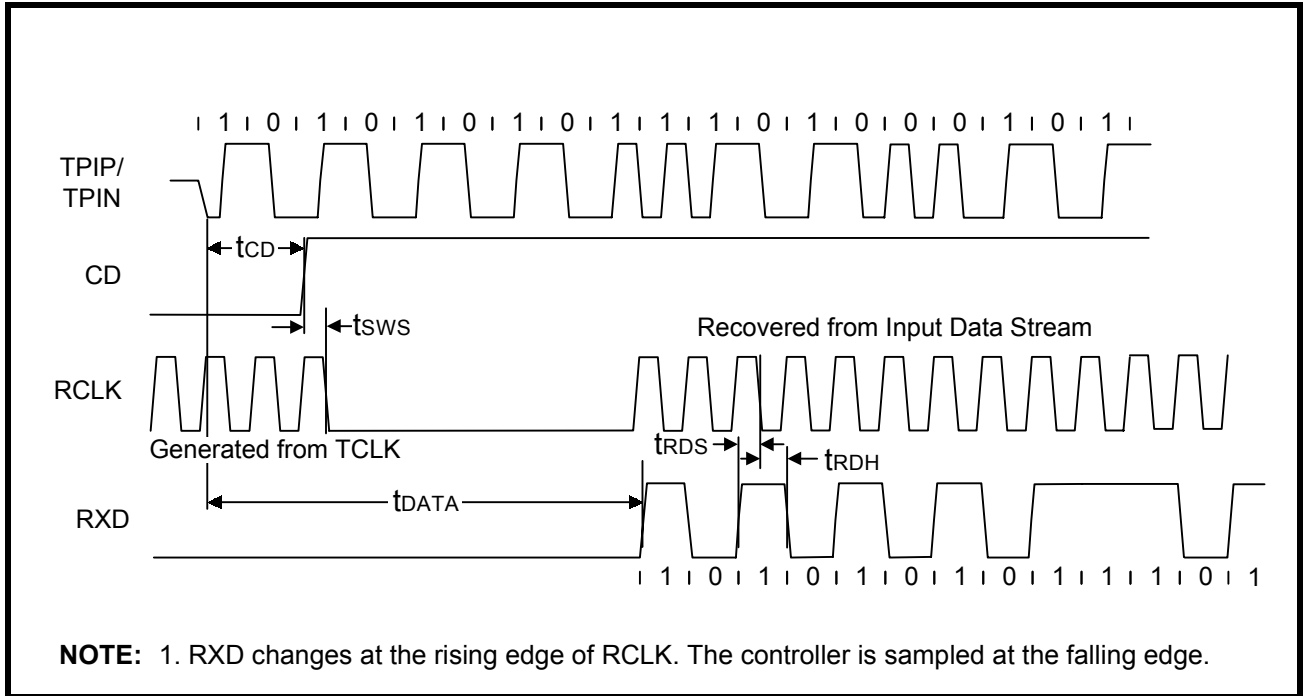

Figure 28: Mode 3 RCLK/End-of-Frame Timing

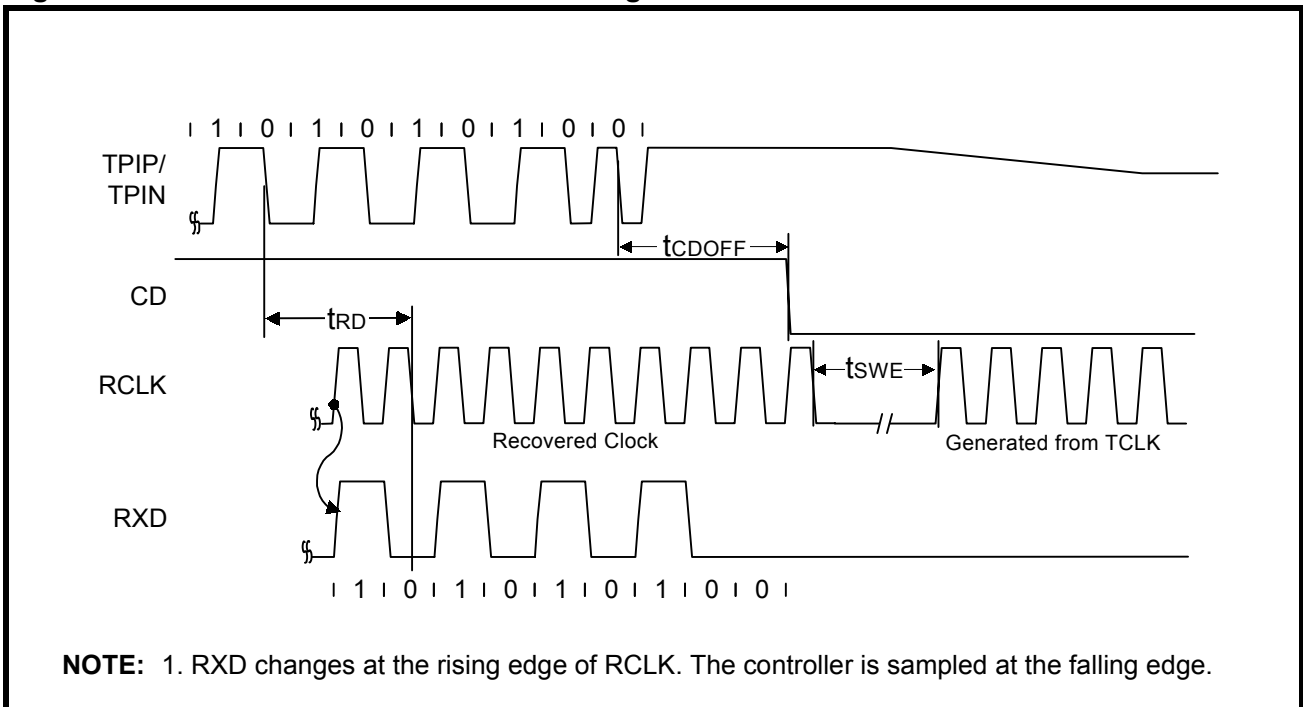

Figure 29: Mode 3 Transmit Timing

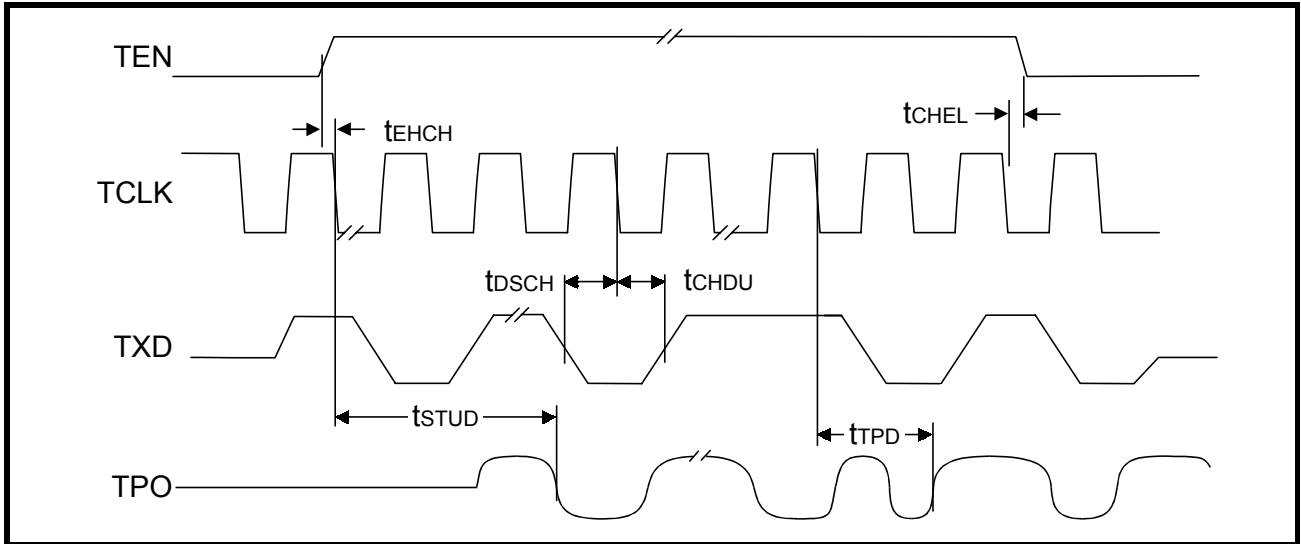

Figure 30: Mode 3 Collision Detect Timing

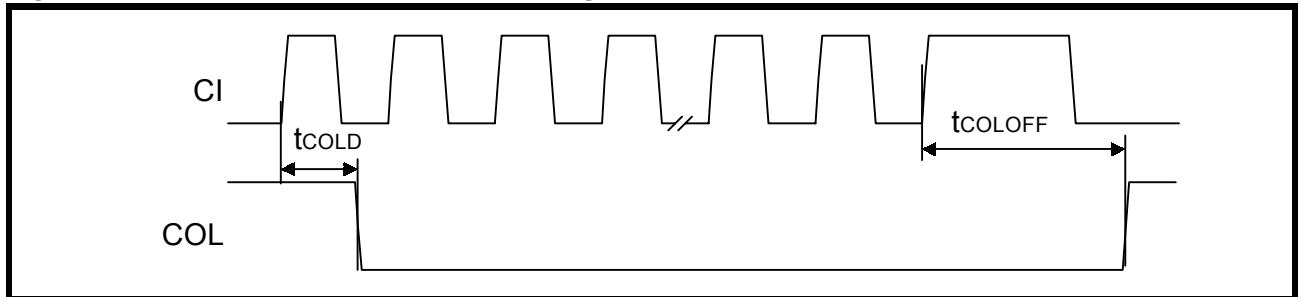

Figure 31: Mode 3 COL/SQE Output Timing

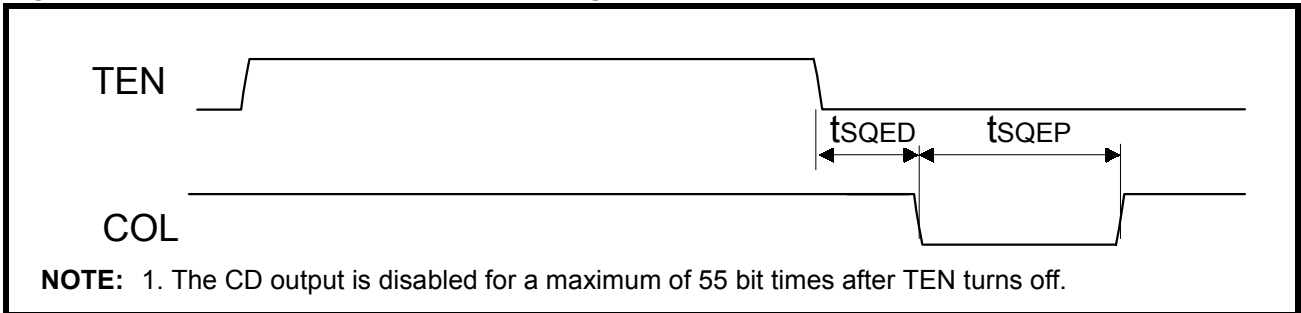
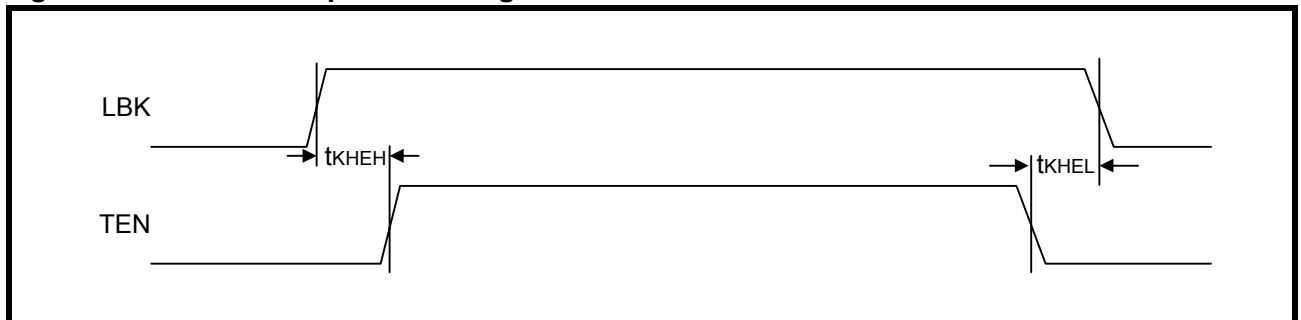

Figure 32: Mode 3 Loopback Timing



Timing Diagrams for Mode 4 (MD2, 1, 0 = Low, High, High) Figures 33 through 38

Figure 33: Mode 4 RCLK/Start-of-Frame Timing

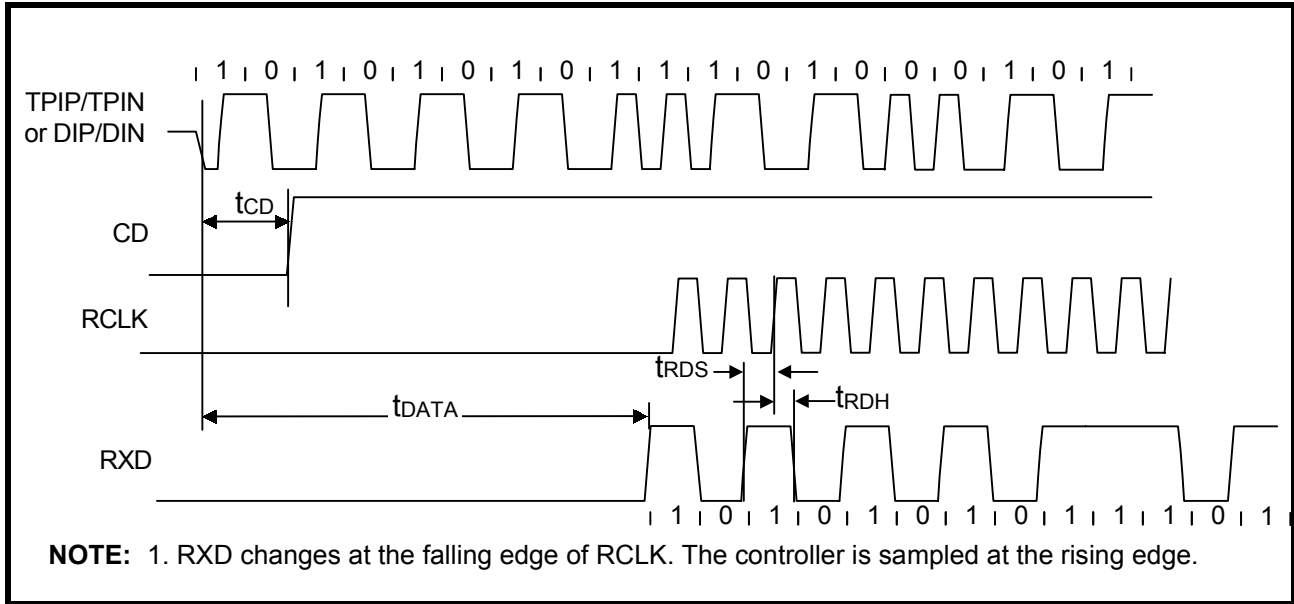

Figure 34: Mode 4 RCLK/End-of-Frame Timing

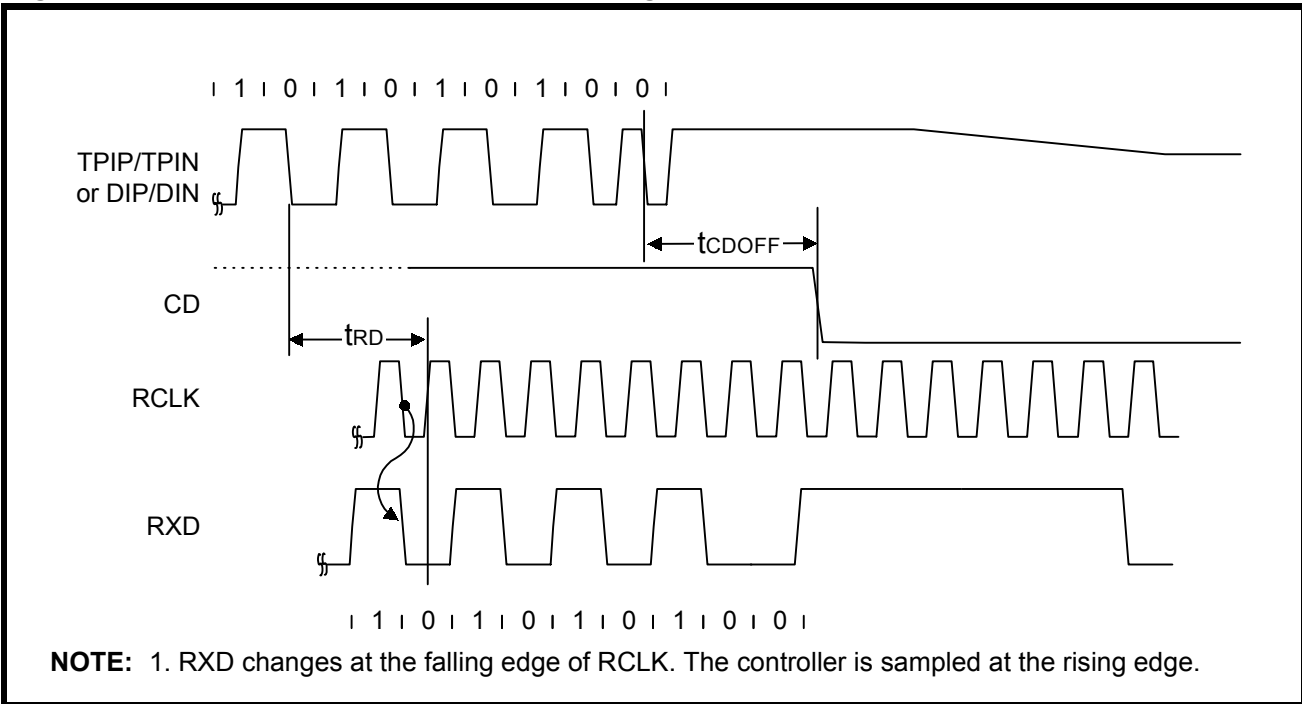

Figure 35: Mode 4 Transmit Timing

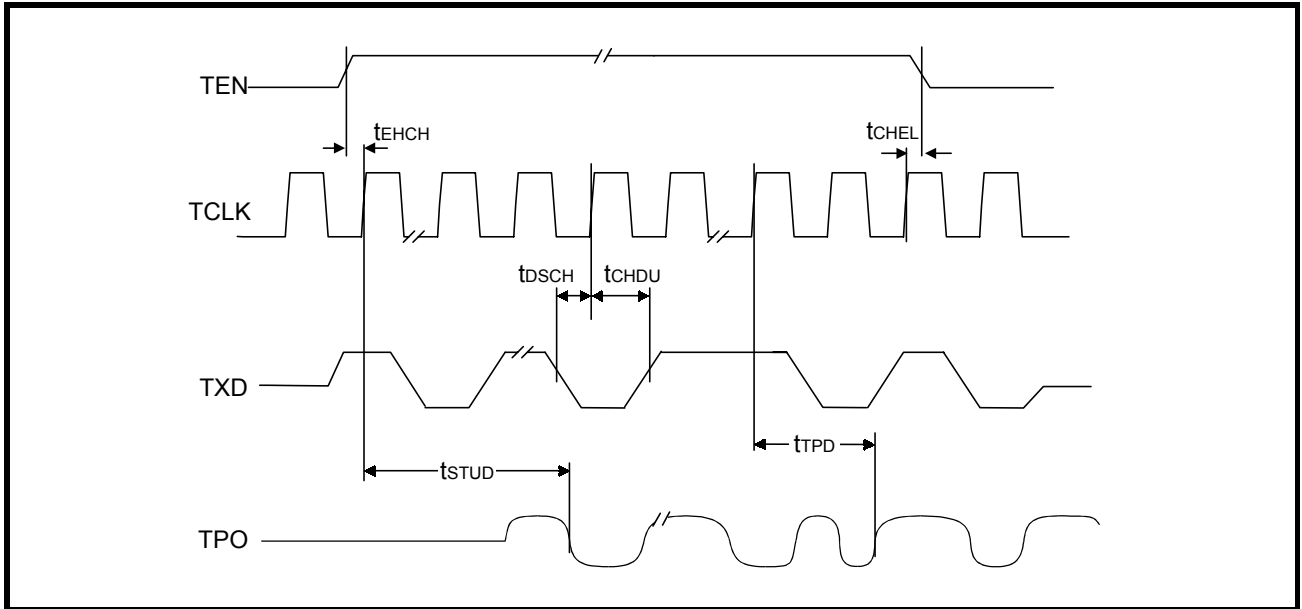

Figure 36: Mode 4 Collision Detect Timing

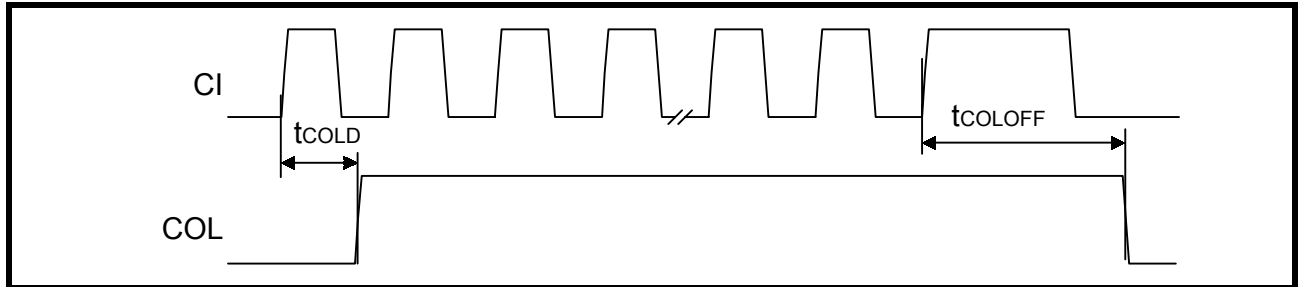

Figure 37: Mode 4 COL/SQE Output Timing

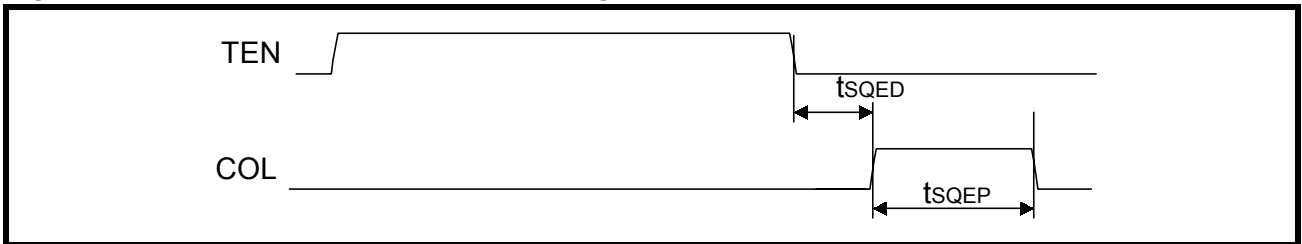
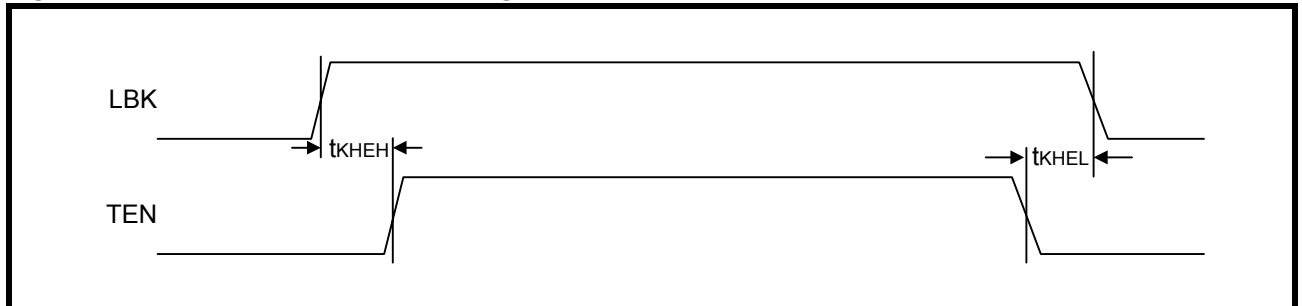

Figure 38: Mode 4 Loopback Timing



Timing Diagrams for Mode 5 (MD2, 1, 0 = High, High, Low) Figures 39 through 44

Figure 39: Mode 5 RCLK/Start-of-Frame Timing

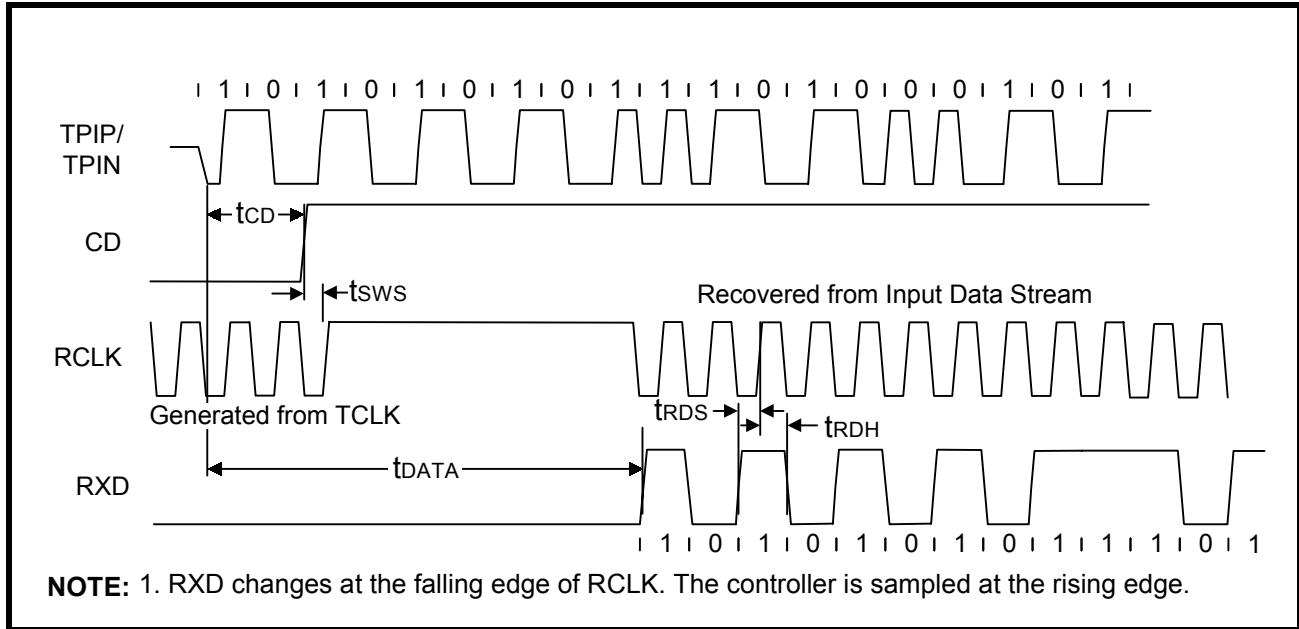

Figure 40: Mode 5 RCLK/End-of-Frame Timing

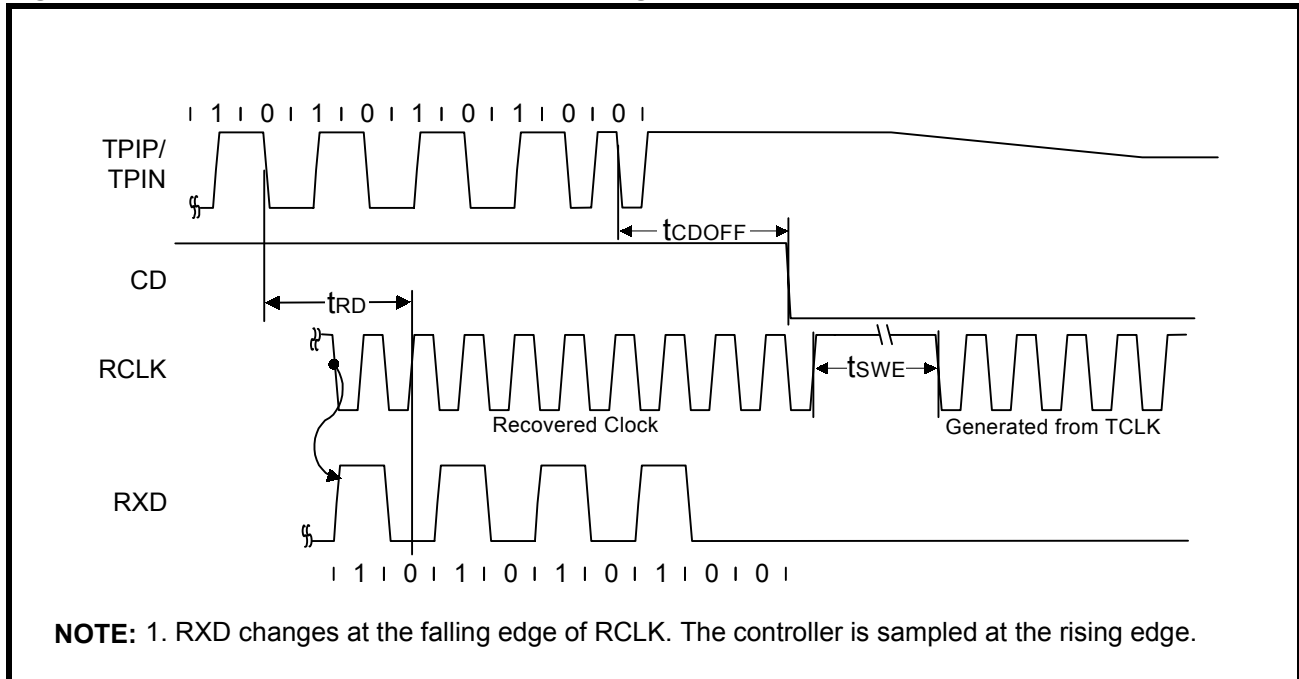

Figure 41: Mode 5 Transmit Timing

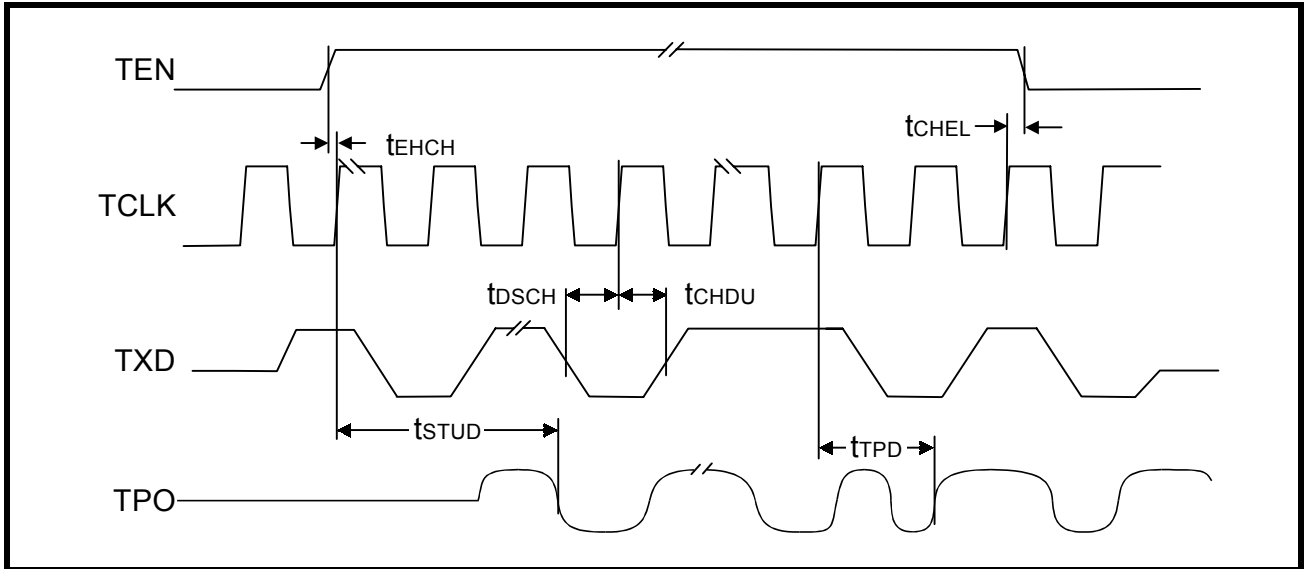

Figure 42: Mode 5 Collision Detect Timing

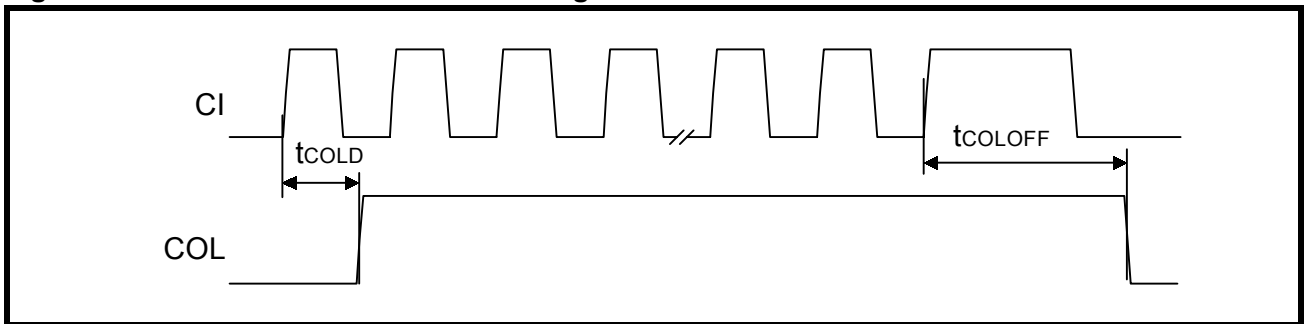

Figure 43: Mode 5 COL/SQE Output Timing

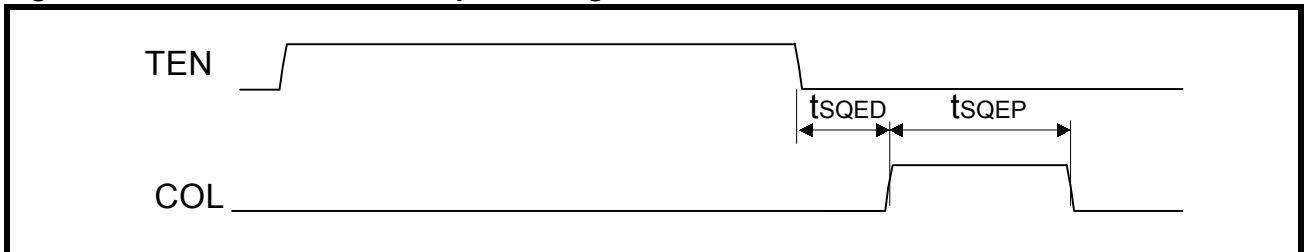
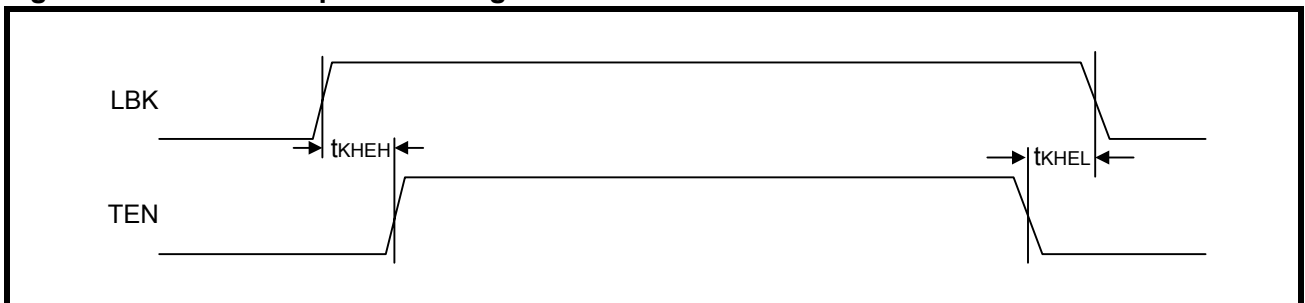

Figure 44: Mode 5 Loopback Timing



NOTES
