HA12228F/HA12229F

Ordering Information

Operating Voltage

Product	Min	Max	Unit
HA12228F	6.5	12	V
HA12229F			

Note: 1. These ICs are designed to operate on single supply.

Standard Level

Product	Package	PB-OUT Level
HA12228F	FP-40B	300 mVrms
HA12229F		

Function

Product	PB-EQ	Music Sensor	Mute	Dolby B-NR
HA12228F	○	○	○	○
HA12229F	○	○	○	×

Pin Description, Equivalent Circuit ($V_{CC} = 9\text{ V}$ single supply, $T_a = 25^\circ\text{C}$, No Signal, The value in the table shows typical value.)

Pin No.	Terminal Name	Note	Equivalent Circuit	Description
13	MSI	$V = V_{CC}/2$		MS input *1
4	TAI(L)			Tape input
27	TAI(R)			
23 *2	DET(R)	$V = 2.5\text{ V}$		Time constant pin for NR rectifier
8 *2	DET(L)			
26	RIP	$V = V_{CC}/2$		Ripple filter
5 *3	Bias	$V = 0.28\text{ V}$		Dolby bias current input
14	MSDET	—		Time constant pin for MS rectifier *1

- Notes: 1. MS: Music Sensor
 2. Non connection regarding HA12229F.
 3. Test pin regarding HA12229F. Usually open or pull down to GND with 18 kΩ.

HA12228F/HA12229F

Pin Description, Equivalent Circuit ($V_{CC} = 9\text{ V}$ single supply, $T_a = 25^\circ\text{C}$, No Signal, The value in the table shows typical value.) (cont.)

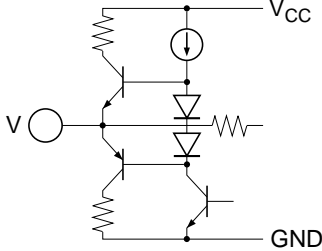
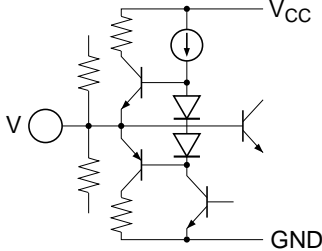
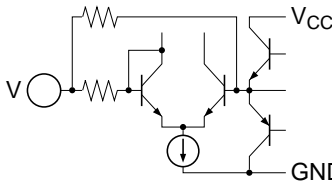
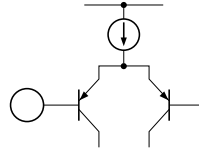
Pin No.	Terminal Name	Note	Equivalent Circuit	Description
25	PBOUT(R)	$V = V_{CC}/2$		PB output
6	PBOUT(L)			
12	MAOUT			MS amp. output *1
29	EQOUT(R)	$V = V_{CC}/2$		Equalizer output
2	EQOUT(L)			
30	M-OUT(R)	$V = V_{CC}/2$		Equalizer output for time constant
1	M-OUT(L)			
37	FIN(R)	—		Equalizer input (FORWARD)
39	FIN(L)			
35	RIN(R)	—		Equalizer input (REVERSE)
33	RIN(L)			

Note: 1. MS: Music Sensor

Pin Description, Equivalent Circuit ($V_{CC} = 9\text{ V}$ single supply, $T_a = 25^\circ\text{C}$, No Signal, The value in the table shows typical value.) (cont.)

Pin No.	Terminal Name	Note	Equivalent Circuit	Description
20	MUTE ON/OFF	—		Mode control input
21 * ¹	NR ON/OFF			
19	120/70			
17	F/R			
18	S/R(MS G _v)			
16	MSOUT	—		MS output (to MPU) * ²
10	MS G _v (S)	$V = V_{CC}/2$		MS gain terminal * ²
11	MS G _v (R)			
31	NFI(R)	$V = V_{CC}/2$		Equalizer output for time constant
40	NFI(L)			

Notes: 1. Non connection regarding HA12229F.

2. MS: Music Sensor

HA12228F/HA12229F

Pin Description, Equivalent Circuit ($V_{CC} = 9\text{ V}$ single supply, $T_a = 25^\circ\text{C}$, No Signal, The value in the table shows typical value.) (cont.)

Pin No.	Terminal Name	Note	Equivalent Circuit	Description
32	VREF1	$V = V_{CC}/2$		Reference output
38	VREF2			
28	VREF3			
3	VREF4			

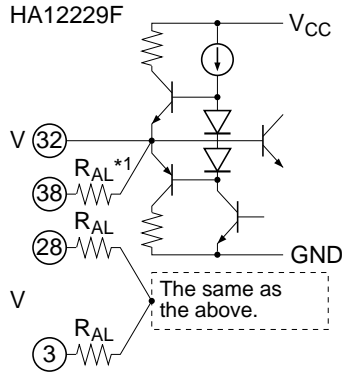

15	V_{CC}	—		V_{CC} pin
36	GND	—		GND pin
7	NC	—		
9				
22				
24				
34				

Note: 1. R_{AL} : Parasitic metal resistance

Block Diagram

HA12228F

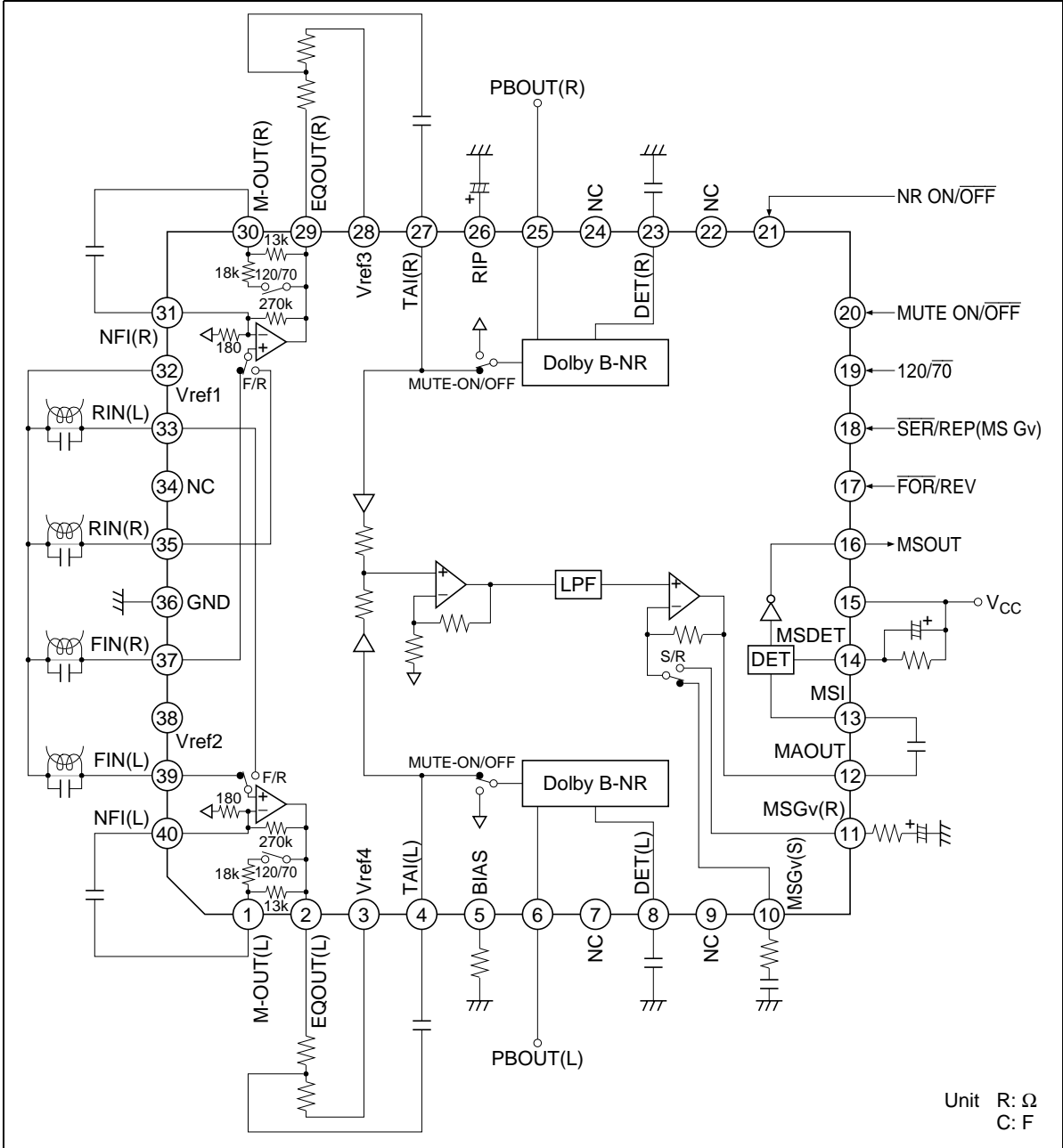

Unit R: Ω
C: F

HA12228F/HA12229F

HA12229F

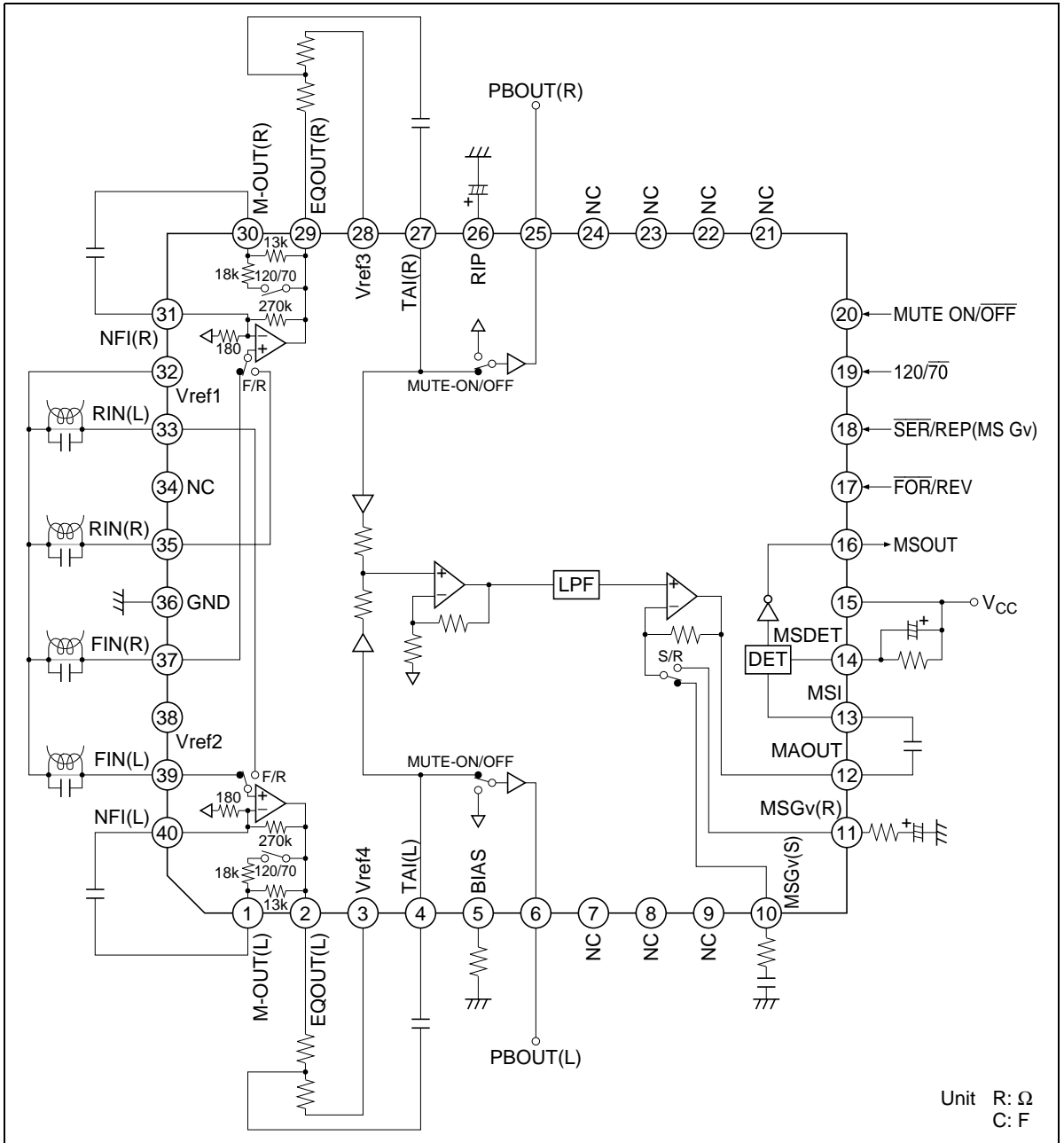

Functional Description

Power Supply Range

HA12228F/HA12229F are provided with three line output level, which will permit on optimum overload margin for power supply conditions. And these are designed to operate on single supply only.

Table 1 Supply Voltage Range

Product	Single Supply
HA12228F	6.5 V to 12.0 V
HA12229F	

Note: The lower limit of supply voltage depends on the line output reference level.
 The minimum value of the overload margin is specified as 12 dB by Dolby Laboratories.

Reference Voltage

These devices provide the reference voltage of half the supply voltage that is the signal grounds. As the peculiarity of these devices, the capacitor for the ripple filter is very small about 1/100 compared with their usual value. The block diagram is shown as figure 1.

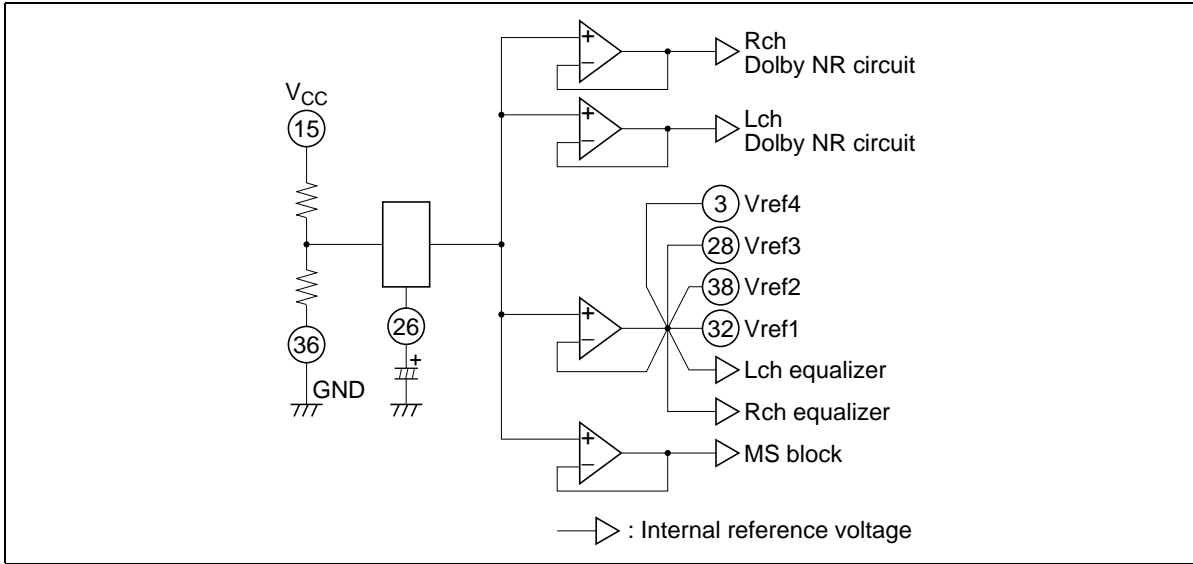

Figure 1a The HA12228F Block Diagram of Reference Supply Voltage

HA12228F/HA12229F

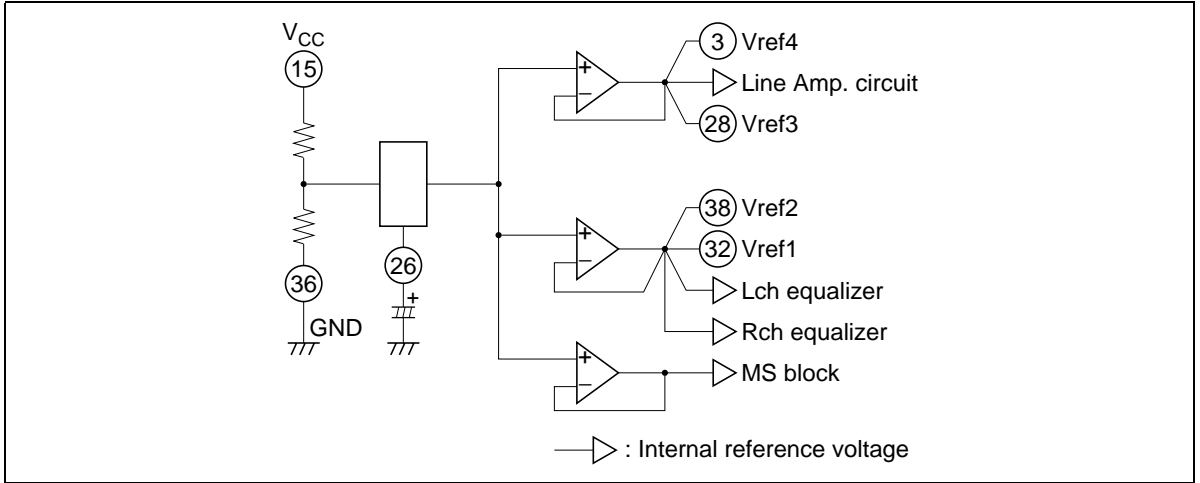

Figure 1b The HA12229F Block Diagram of Reference Supply Voltage

Operating Mode Control

HA12228F/HA12229F provides fully electronic switching circuits. And each operating mode control are controlled by parallel data (DC voltage).

When a power supply of this IC is cut off, for a voltage, in addition to a mode control terminal even though as do not destruct it, in series for resistance.

Table 2 Threshold Voltage (V_{TH})

Pin No.	Lo	Hi	Unit	Test Condition
17, 18, 19, 20, 21*	-0.2 to 1.0	3.5 to V_{CC}	V	Input Pin Measure

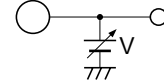

Note: * Non connection regarding HA12229F.

Table 3 Switching Truth Table

Pin No.	Pin Name	Lo	Hi
17	Forward/Reverse	Forward	Reverse
18	Search/Repeat	Search (FF or REV)	Repeat (Normal speed)
19	120 μ/70 μ	70 μ (Metal or Chrome)	120 μ (Normal)
20	MUTE ON/OFF	MUTE-OFF	MUTE-ON
21*	NR ON/OFF	NR-OFF	NR-ON

Notes: * Non connection regarding HA12229F.

1. Each pins are on pulled down with 100 kΩ internal resistor. Therefore, it will be low-level when each pins are open.
2. Over shoot level and under shoot level of input signal must be the standardized. (High: V_{CC} , Low: -0.2 V)
3. Reducing pop noise is so much better for 10 kΩ to 22 kΩ resistor and 1 μF to 22 μF capacitor shown figure 2.

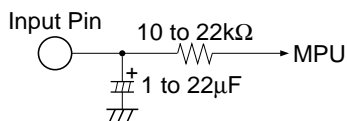

Figure 2 Interface for Reduction of Pop Noise

HA12228F/HA12229F

Input Block Diagram and Level Diagram

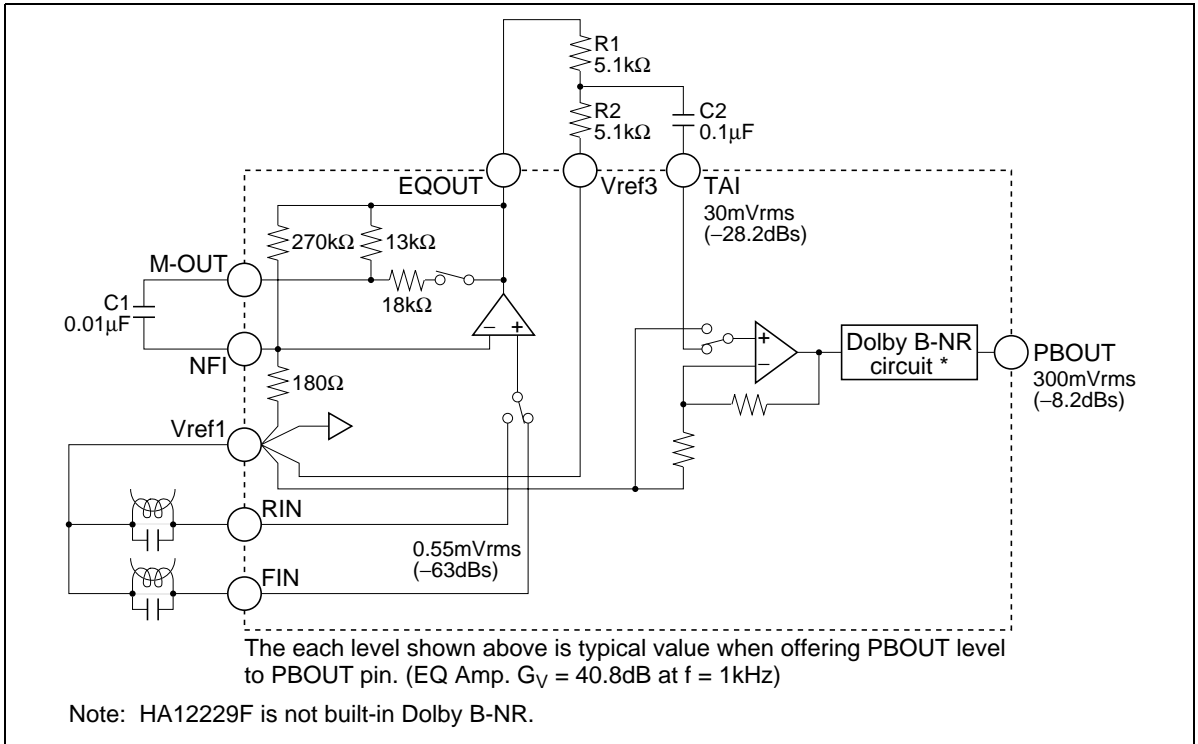

Figure 3 Input Block Diagram

Adjustment of Playback Dolby Level

After replace R5 and R6 with a half-fix volume of 10 kΩ, adjust playback Dolby level.

The Sensitivity Adjustment of Music Sensor

Adjusting MS Amp. gain by external resistor, the sensitivity of music sensor can set up. The music sensor block diagram is shown in figure 4, and frequency response is shown in figure 5.

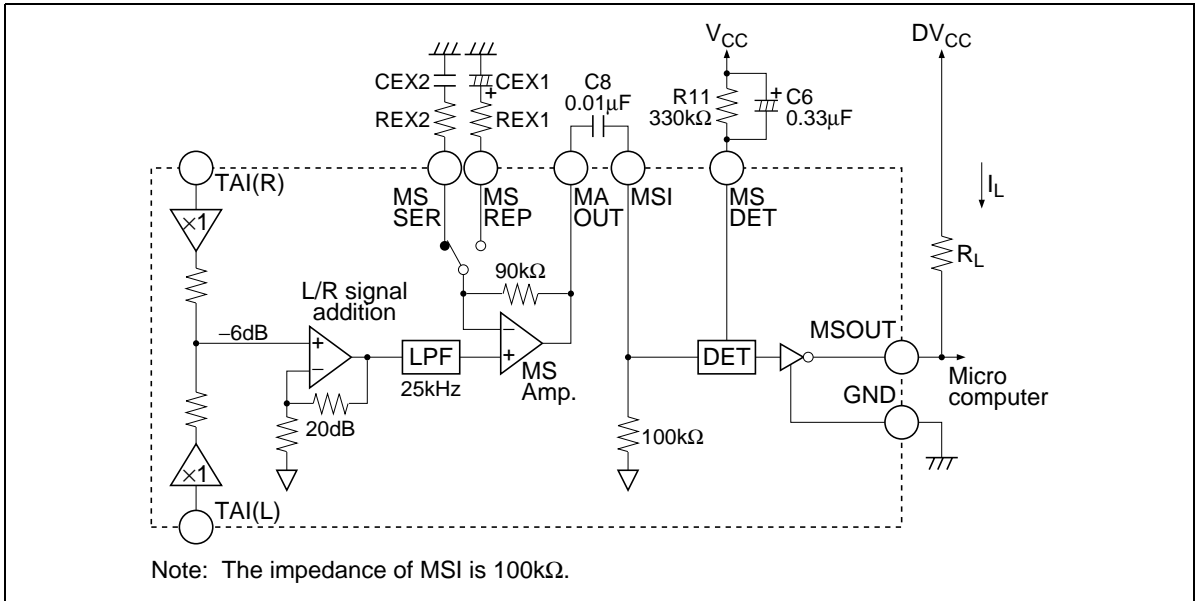

Figure 4 Music Sensor Block Diagram

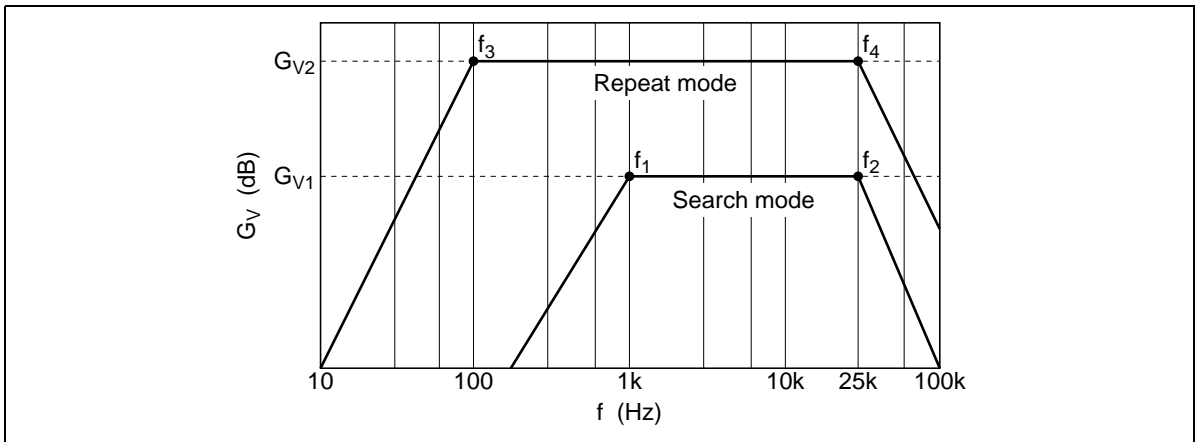

Figure 5 Frequency Response

HA12228F/HA12229F

1. Search mode

$$G_{V1} = 20\text{dB} + 20 \log \left(1 + \frac{90\text{k}}{\text{REX2}} \right) \text{ [dB]}$$

$$f_1 = \frac{1}{2\pi \cdot \text{CEX2} \cdot \text{REX2}} \text{ [Hz]}, \quad f_2 = 25\text{k} \text{ [Hz]}$$

2. Repeat mode

$$G_{V2} = 20\text{dB} + 20 \log \left(1 + \frac{90\text{k}}{\text{REX1}} \right) \text{ [dB]}$$

$$f_3 = \frac{1}{2\pi \cdot \text{CEX1} \cdot \text{REX1}} \text{ [Hz]}, \quad f_4 = 25\text{k} \text{ [Hz]}$$

G_{VIA} : L-R signal addition circuit gain.

The sensitivity of music sensor (S) is computed by the formula mentioned below.

$$S = - \left(G_{V1} - 20 \log \frac{130^{*3}}{30^{*2}} \right) = 12.7 - G_V \text{ [dB]}$$

- Note:
1. Search mode: G_{V1} , Repeat mode: G_{V2}
 2. Standard level of TAI pin (Dolby level correspondence) = 30 mVrms
 3. Standard sensing level of music sensor = 130 mVrms

Item	REX1, 2	CEX1, 2	$G_{V1,2}$	$f_{1,3}$	$f_{2,4}$	S (one side channel)	S (both channel)
Search mode	24 k Ω	0.01 μ F	33.5 dB	663 Hz	25 kHz	-14.8 dB	-20.8 dB
Repeat mode	2.4 k Ω	1 μ F	51.7 dB	66.3 Hz	25 kHz	-33.0 dB	-39.0 dB

Note: S is 6 dB down in case of one-side channel. And this MS presented hysteresis lest MSOUT terminal should turn over again High level or Low level, in case of thresh S level constantly.

Music Sensor Time Constant

1. Sensing no signal to signal (Attack) is determined by C6, 0.01 μ F to 1 μ F capacitor C6 can be applicable.
2. Sensing signal to no signal (Recovery) is determined by C6 and R11, however preceding (1), 100 k Ω to 1 M Ω can be applicable.

Music Sensor Output (MSOUT)

As for the internal circuit of music sensor block, music sensor output pin is connected to the collector of NPN type directly, therefore, output level will be “high” when sensing no signal. And output level will be “low” when sensing signal.

$$I_L = \frac{DV_{CC} - \text{MSOUT}_{LO}^*}{R_L}$$

* MSOUT_{LO} : Sensing signal (about 1V)

Note: 1. Supply voltage of MSOUT pin must be less than V_{CC} voltage.

The Tolerances of External Components for Dolby NR (Only HA12228F)

For adequate Dolby NR tracking response, take external components shown below.
Also, leak is small capacity, and please employ a good quality object.

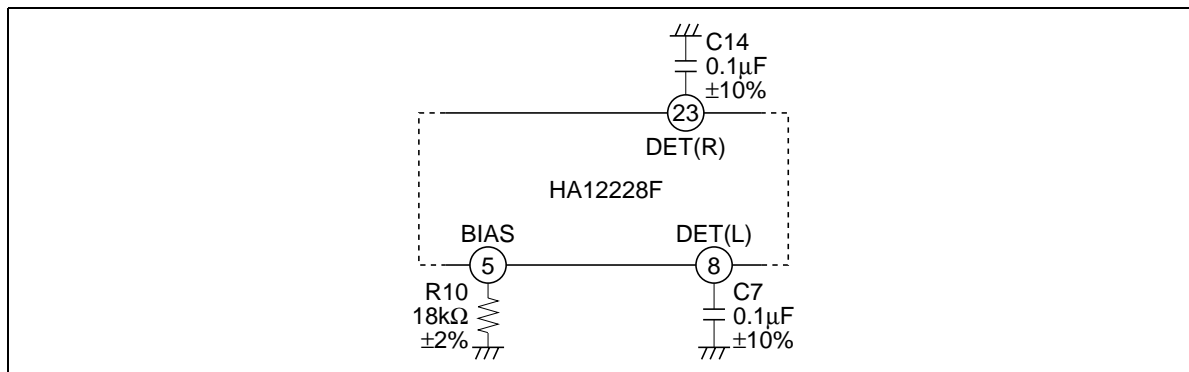

Figure 6 Tolerance of External Components

Countermeasure of a Cellular Phone Noise

This IC have reinforced a cellular phone noise countermeasure, to show it hereinafter.

However, it is presumed that this effect change it greatly, by a mount set.

Please sufficiently examine an arrangement of positions, shield method, wiring pattern, in order to obtain a maximum effect.

A high terminal of a noise sensitivity of this IC is FIN, RIN, NFI and RIP.

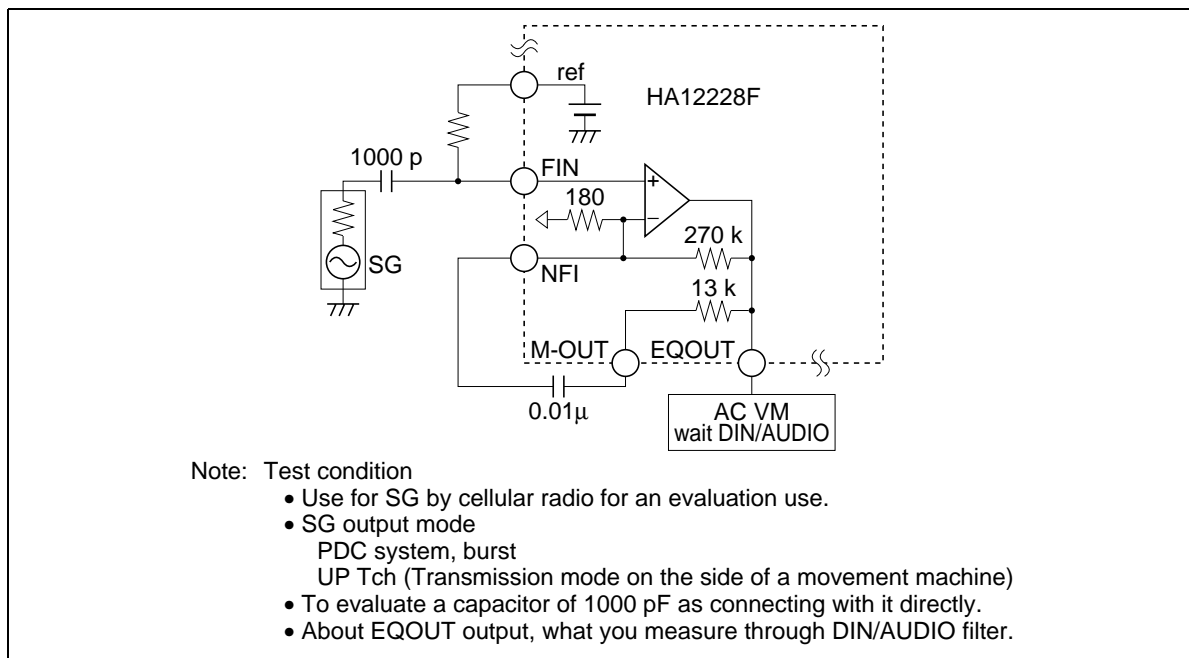

Note: Test condition

- Use for SG by cellular radio for an evaluation use.
- SG output mode
PDC system, burst
UP Tch (Transmission mode on the side of a movement machine)
- To evaluate a capacitor of 1000 pF as connecting with it directly.
- About EQOUT output, what you measure through DIN/AUDIO filter.

Figure 7 Test Circuit

HA12228F/HA12229F

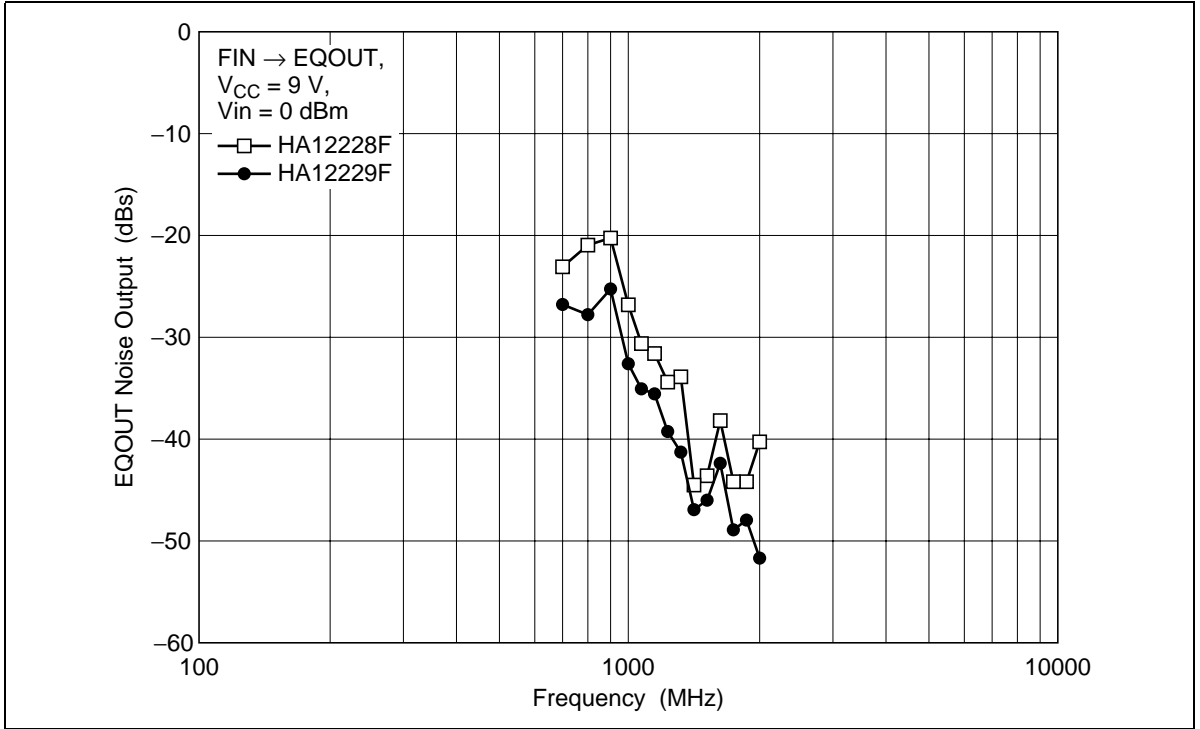

Figure 8 EQOUT Noise Output vs. Transmission Frequency Characteristic

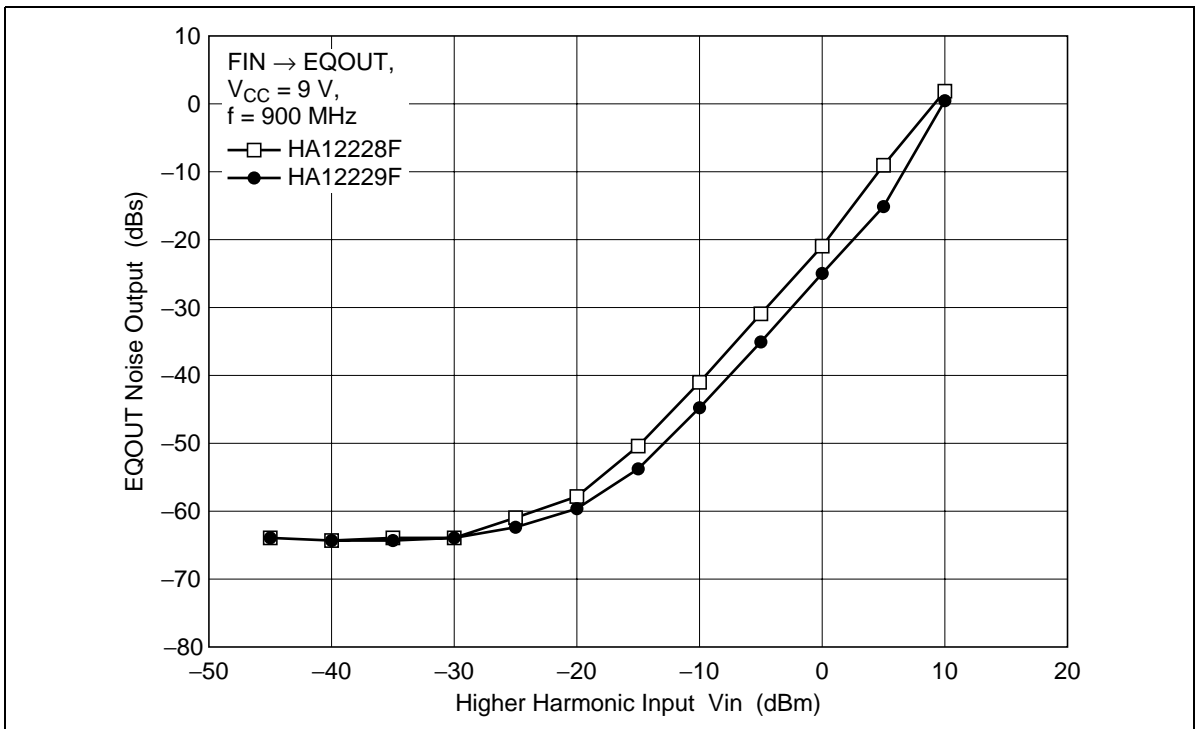

Figure 9 EQOUT Noise Output vs. Transmission Signal Input Level Characteristic

Absolute Maximum Ratings (Ta = 25°C)

Item	Symbol	Rating	Unit	Note
Maximum supply voltage	V _{cc} Max	16	V	
Power dissipation	Pd	400	mW	Ta ≤ 85°C
Operating temperature	Topr	-40 to +85	°C	
Storage temperature	Tstg	-55 to +125	°C	

HA12228F/HA12229F

Electrical Characteristics

HA12228F

(Ta = 25°C, V_{CC} = 9 V, Dolby level 0 dB = PBOULT level 0 dB = PBOULT level 0 dB = 300 mVrms, EQOUT level 0 dB = 60 mVrms)

Item	Symbol	Test Condition										Specification						Application Terminal			
		IC Condition					Test Condition					Min	Typ	Max	Unit	Input		Output		COM	Remark
		NR ON/OFF	MUTE ON/OFF	120μ/70μ	SER/REP	FOR/REV	fin (Hz)	PBOULT level (dB)	EQOUT level (dB)	Other	R					L	R	L			
Quiescent current	I _Q	OFF	OFF	70μ	SER	FOR	1k	—	—	—	No signal	4.0	9.5	15.0	mA	—	—	—	—	15	
Input Amp. gain B-type decode cut	G _V /A	OFF	OFF	—	—	—	1k	0	—	—	—	19.0	20.0	21.0	dB	27	4	25	6		
	DEC 2k (1)	ON	OFF	—	—	—	2k	-20	—	—	—	-5.8	-4.3	-2.8	dB	27	4	25	6		
	DEC 2k (2)	ON	OFF	—	—	—	2k	-30	—	—	—	-10.0	-8.5	-7.0	dB	27	4	25	6		
	DEC 5k (1)	ON	OFF	—	—	—	5k	-20	—	—	—	-4.7	-3.2	-1.7	dB	27	4	25	6		
	DEC 5k (2)	ON	OFF	—	—	—	5k	-30	—	—	—	-9.7	-8.2	-6.7	dB	27	4	25	6		
PBOULT offset	V _{ofs}	OFF	OFF→ON	—	—	—	—	—	—	—	No signal	-150	0	150	mV	—	—	25	6	1	
Signal handling	V _{o max}	ON	OFF	—	—	—	1k	—	—	—	THD=1%	12.0	13.0	—	dB	27	4	25	6	2	
Signal to noise ratio	S/N	ON	OFF	—	—	—	1k	(0)	—	—	Rg=10kΩ, CCIR/ARM	70.0	80.0	—	dB	27	4	25	6		
Total Harmonic Distortion	THD	ON	OFF	—	—	—	1k	0	—	—	—	—	0.05	0.3	%	27	4	25	6		
Channel separation	CTRL (1)	—	—	—	—	FOR	1k	(+20)	—	—	—	50.0	60.0	—	dB	37	39	29	2	2	2
	CTRL (2)	OFF	OFF	—	—	—	1k	(+12)	—	—	—	70.0	80.0	—	dB	27	4	25	6	2	2
MUTE attenuation	CT MUTE	OFF	OFF→ON	—	—	—	1k	(+12)	—	—	—	70.0	80.0	—	dB	27	4	25	6		
PB-EQ gain	G _V EQ 1k	—	—	120μ	—	FOR/REV	1k	—	—	—	—	37.8	40.8	43.8	dB	37/35	39/33	29	2		
	G _V EQ 10k(1)	—	—	120μ	—	FOR	10k	—	—	—	—	33.9	36.9	39.9	dB	37	39	29	2		
	G _V EQ 10k(2)	—	—	70μ	—	FOR	10k	—	—	—	—	29.6	32.6	35.6	dB	37	39	29	2		
PB-EQ Maximum output level	V _{OM}	—	—	120μ	—	FOR	1k	—	—	—	THD=1%	300	600	—	mVrms	37	39	29	2		
PB-EQ T.H.D.	THD-EQ	—	—	120μ	—	FOR/REV	1k	—	—	—	+14dB	—	0.1	0.3	%	37/35	39/33	29	2		
PB-EQ input conversion noise	V _N	—	—	120μ	—	FOR/REV	(1k)	—	—	—	Rg=680Ω, DIN-AUDIO	—	0.7	1.5	μVrms	37/35	39/33	29	2		
MS sensing level	V _{ON} (1)	OFF	OFF	—	SER	—	5k	—	—	—	—	-36.0	-32.0	-28.0	dB	27	4	25	6	16	3
	V _{ON} (2)	OFF	OFF	—	REP	—	5k	—	—	—	—	-18.0	-14.0	-10.0	dB	27	4	25	6	16	3
MS output low level	V _{OL}	OFF	OFF	—	SER	—	5k	0	—	—	—	—	1.0	1.5	V	27	4	—	—	16	
MS output leakage current	I _{OH}	—	—	—	—	—	—	—	—	—	No signal	—	0.0	2.0	μA	—	—	—	—	16	
Control voltage	V _{IL}	—	—	—	—	—	—	—	—	—	—	-0.2	—	—	V	—	—	—	—	17 to 21	
	V _{IH}	—	—	—	—	—	—	—	—	—	—	3.5	—	V _{CC}	V	—	—	—	—	—	

- Notes: 1. V_{CC} = 12V
 2. V_{CC} = 6.5V
 3. For inputting signal to one side channel

HA12229F

(Ta = 25°C, V_{CC} = 9 V, P_{BOUT} level 0 dB = 300 mVrms, EQOUT level 0 dB = 60 mVrms)

Item	Symbol	Test Condition										Specification				Application Terminal						
		IC Condition					Other					Min	Typ	Max	Input		Output		COM	Remark		
		MUTE ON/OFF	120μ/70μ SER	SER/REP	FOR/REV	fin (Hz)	PBOUT level (dB)	EQOUT level (dB)	No signal	Other	Unit				R	L	R	L				
Quiescent current	I _Q	OFF	—	—	FOR	—	—	—	—	1k	0	—	3.0	5.0	8.0	mA	—	—	—	15		
Input Amp. gain	G _V IA	OFF	—	—	—	—	—	—	—	1k	—	—	19.0	20.0	21.0	dB	27	4	25	6		
PBOUT offset	V _{ofs}	OFF→ON	—	—	—	—	—	—	—	—	—	—	-150	0	150	mV	—	—	25	6	1	
Signal handling	V _{o max}	OFF	—	—	—	1k	—	—	—	1k	—	—	12.0	13.0	—	dB	27	4	25	6	2	
Signal to noise ratio	S/N	OFF	—	—	—	1k	(0)	—	—	1k	—	—	70.0	80.0	—	dB	27	4	25	6	—	
Total Harmonic Distortion	THD	OFF	—	—	—	1k	0	—	—	1k	—	—	—	0.05	0.3	—	dB	27	4	25	6	—
Channel separation	CTRL (1)	—	—	—	FOR	1k	(+20)	—	—	1k	—	—	50.0	60.0	—	dB	37	39	29	2	29	
	CTRL (2)	OFF	—	—	—	1k	(+12)	—	—	1k	—	—	70.0	80.0	—	dB	27	4	25	6	25	
MUTE attenuation	CT MUTE	OFF→ON	—	—	—	1k	(+12)	—	—	1k	—	—	70.0	80.0	—	dB	27	4	25	6	—	
PB-EQ gain	G _V EQ 1k	—	120μ	—	FOR/REV	1k	—	0	—	1k	—	—	37.8	40.8	43.8	dB	37/35	39/33	29	2	—	
	G _V EQ 10k(1)	—	120μ	—	FOR	10k	—	0	—	10k	—	—	33.9	36.9	39.9	dB	37	39	29	2	—	
	G _V EQ 10k(2)	—	70μ	—	FOR	10k	—	0	—	10k	—	—	29.6	32.6	35.6	dB	37	39	29	2	—	
PB-EQ Maximum output level	V _{OM}	—	120μ	—	FOR	1k	—	—	—	1k	—	—	300	600	—	mVrms	37	39	29	2	—	
PB-EQ T.H.D.	THD-EQ	—	120μ	—	FOR/REV	1k	—	+14dB	—	1k	—	—	—	0.1	0.3	%	37/35	39/33	29	2	—	
PB-EQ input conversion noise	V _N	—	120μ	—	FOR/REV	(1k)	—	—	—	(1k)	—	—	—	0.7	1.5	μVrms	37/35	39/33	29	2	—	
MS sensing level	V _{ON} (1)	OFF	—	SER	—	5k	—	—	—	5k	—	—	-36.0	-32.0	-28.0	dB	27	4	25	6	16	
	V _{ON} (2)	OFF	—	REP	—	5k	—	—	—	5k	—	—	-18.0	-14.0	-10.0	dB	27	4	25	6	16	
MS output low level	V _{OL}	OFF	—	SER	—	5k	0	—	—	5k	—	—	—	1.0	1.5	V	27	4	—	—	16	
MS output leakage current	I _{OH}	—	—	—	—	—	—	—	—	—	—	—	—	0.0	2.0	μA	—	—	—	—	16	
Control voltage	V _{IL}	—	—	—	—	—	—	—	—	—	—	—	-0.2	—	1.0	V	—	—	—	—	17 to 20	
	V _{IH}	—	—	—	—	—	—	—	—	—	—	—	3.5	—	V _{CC}	V	—	—	—	—	—	

Notes: 1. V_{CC} = 12V
 2. V_{CC} = 6.5V
 3. For inputting signal to one side channel

HA12228F/HA12229F

Test Circuit

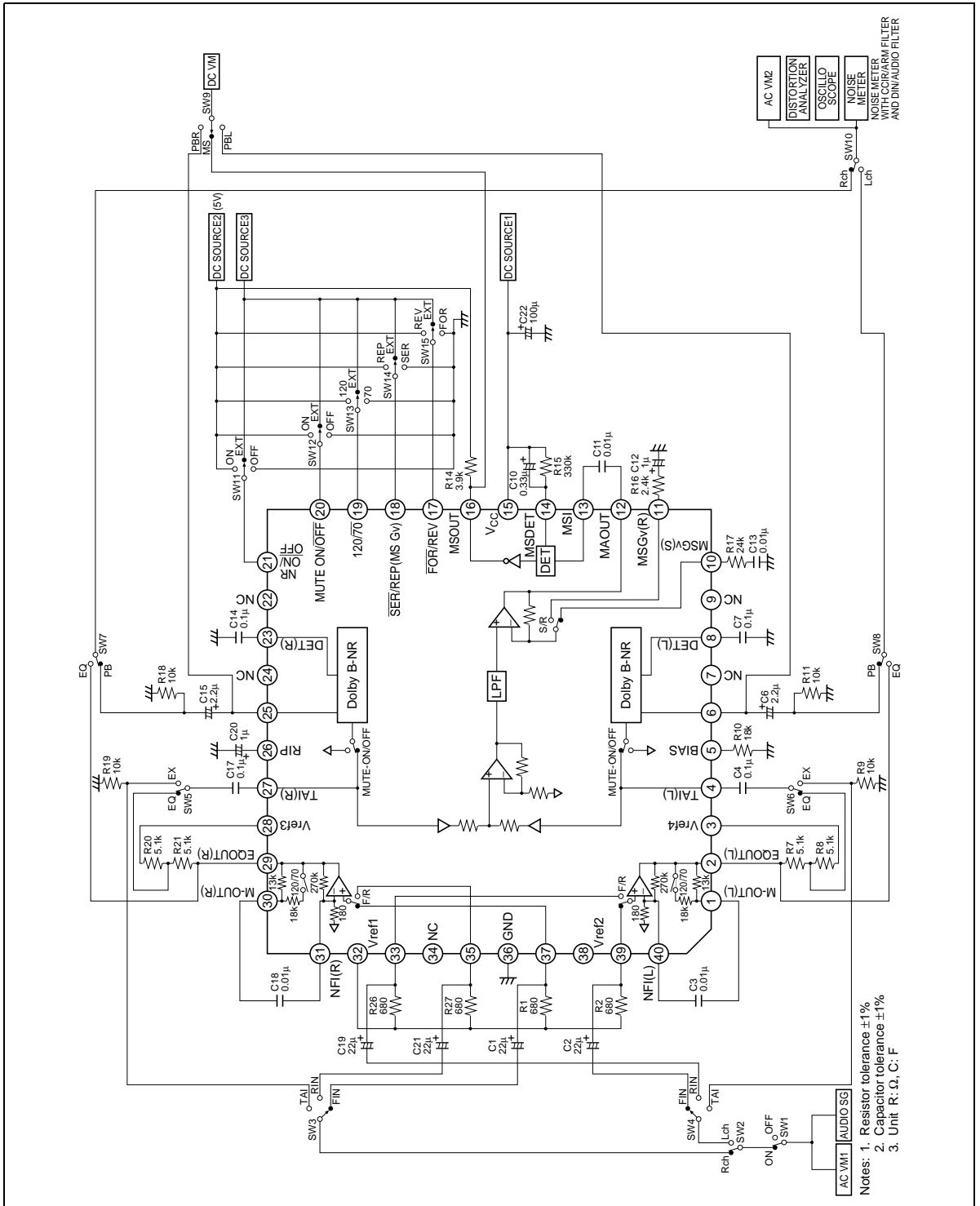

Characteristic Curves

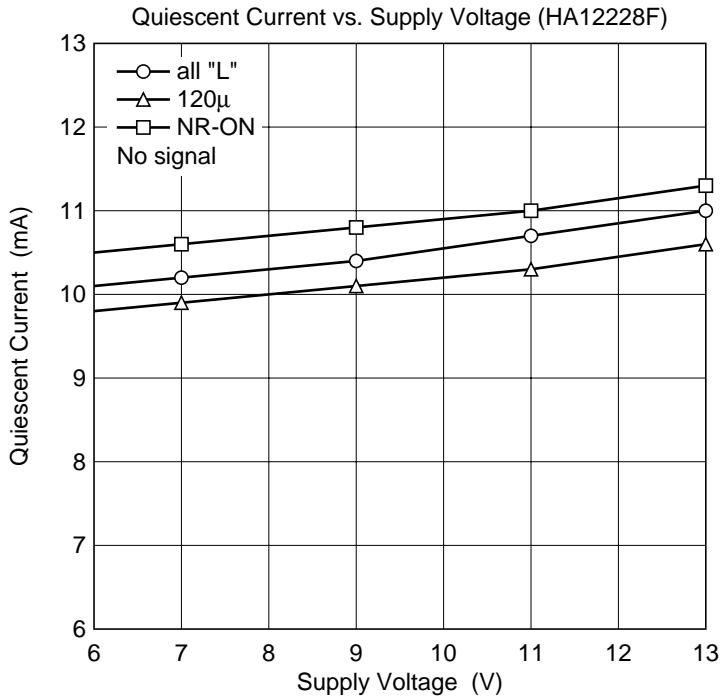
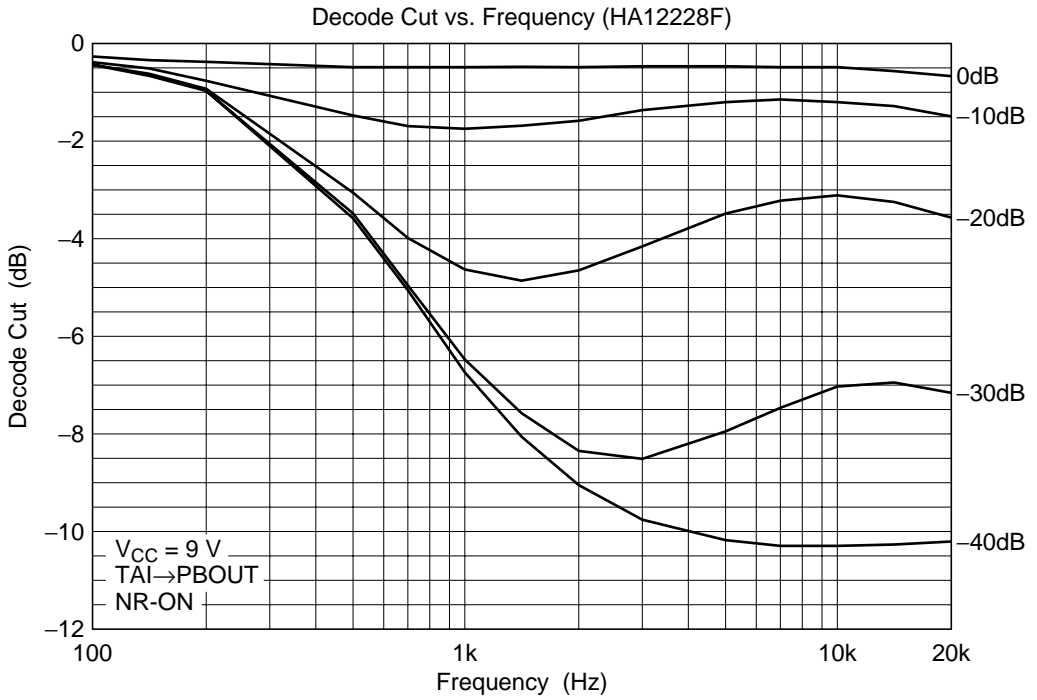

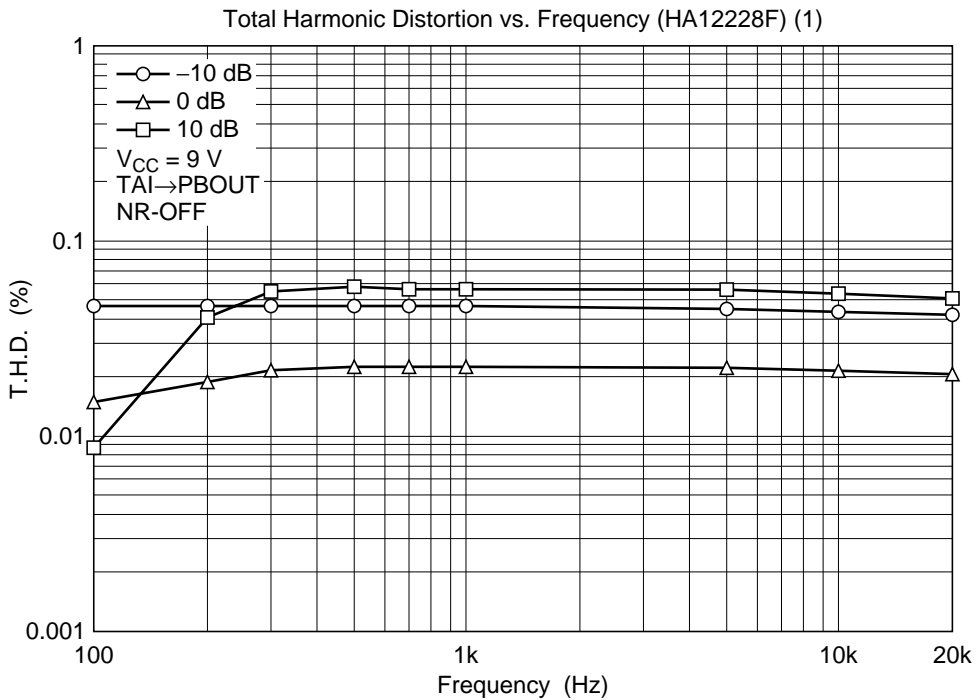
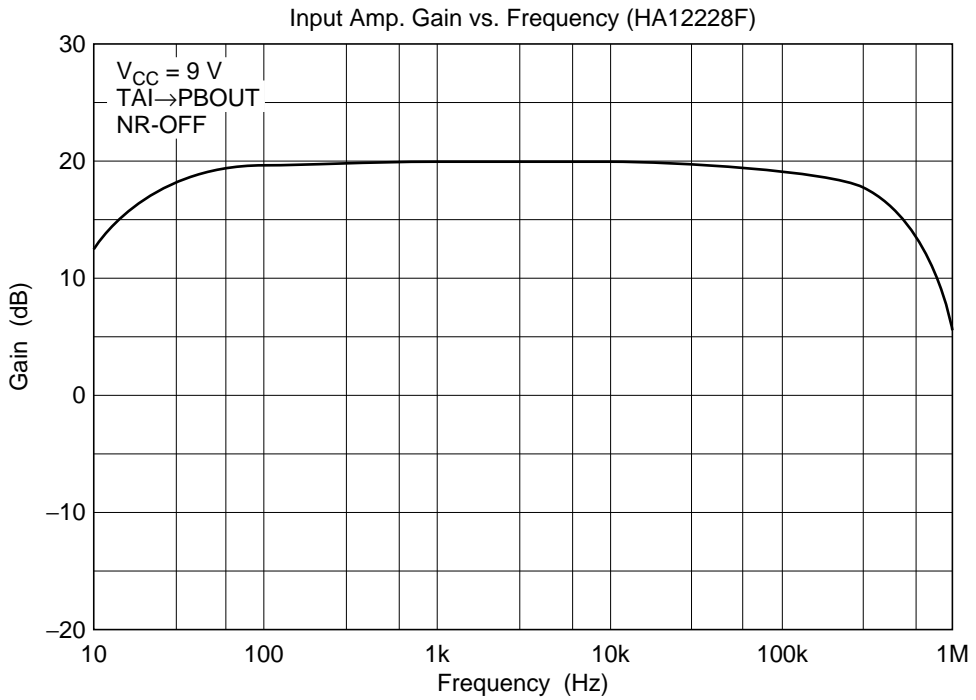

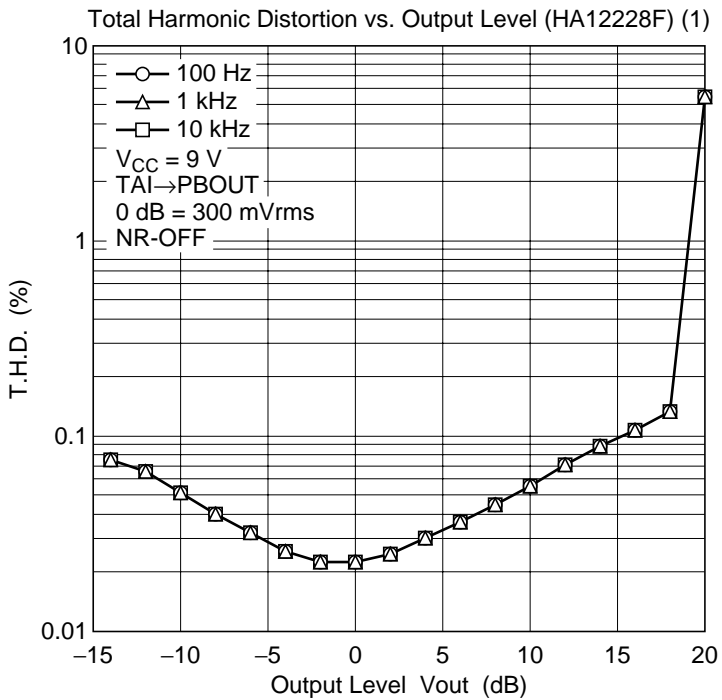
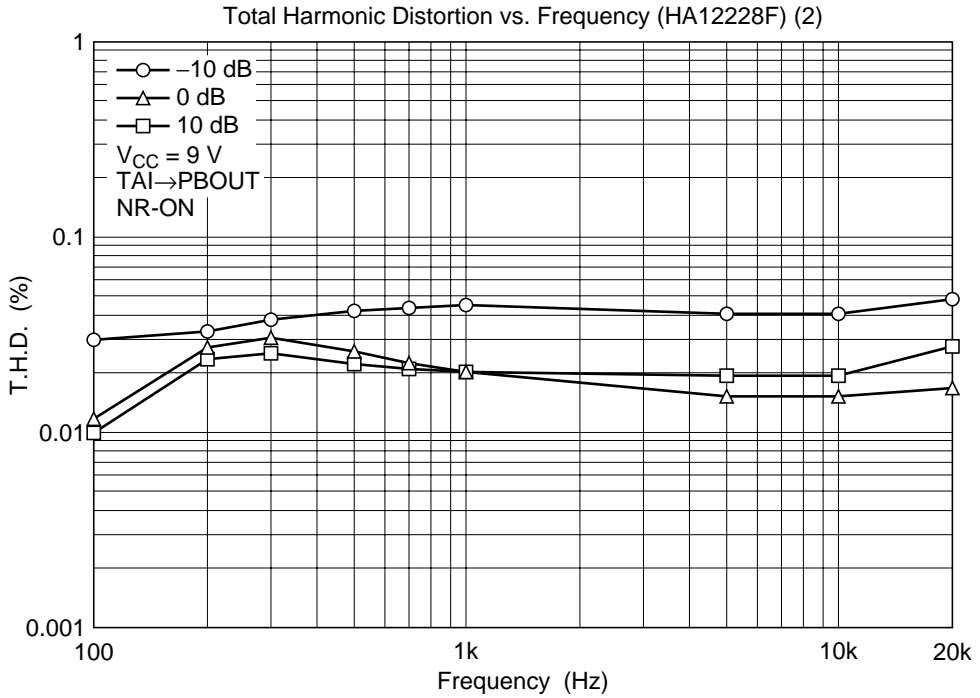

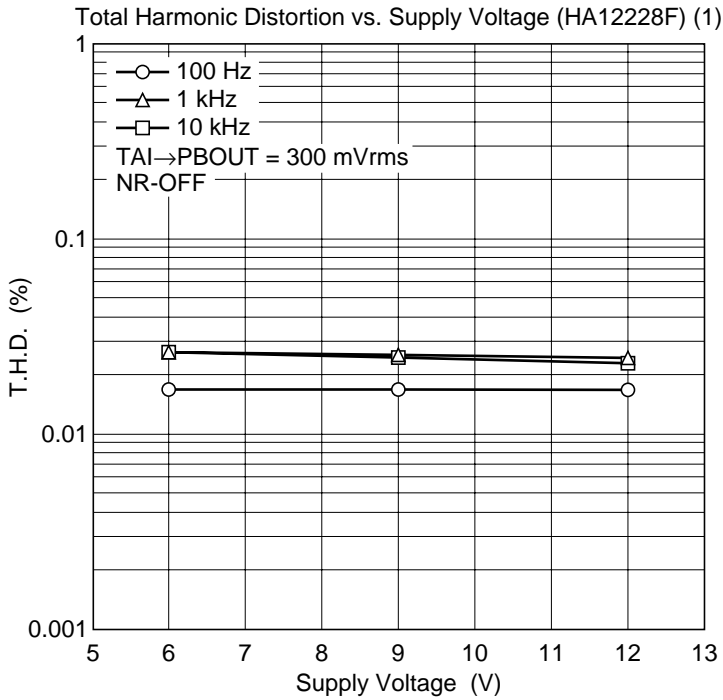
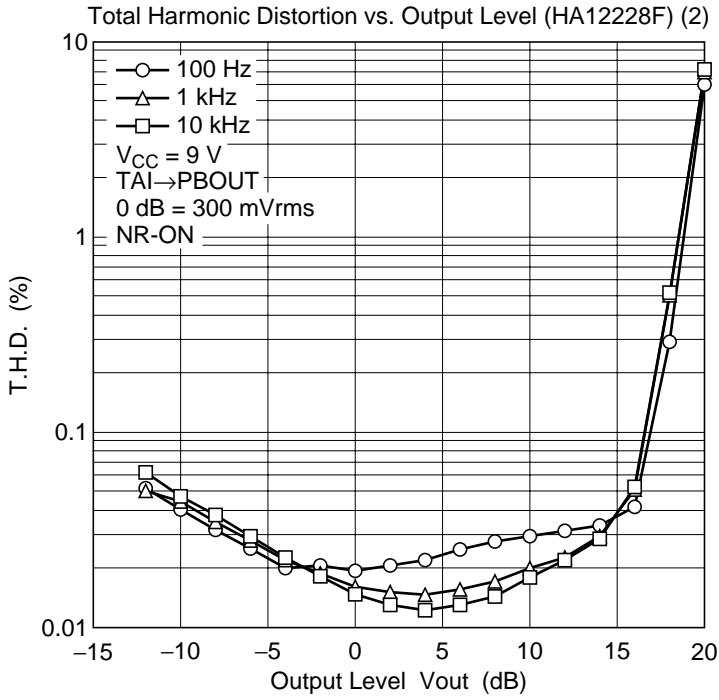

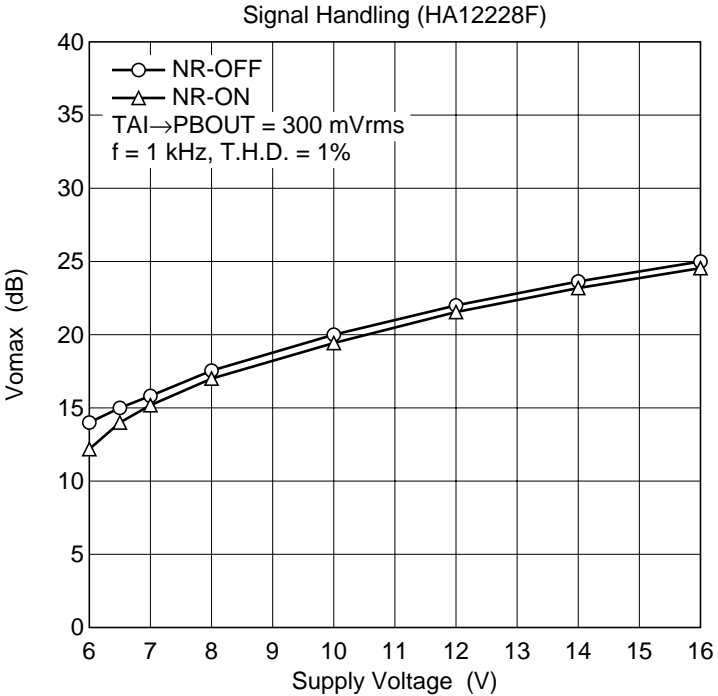
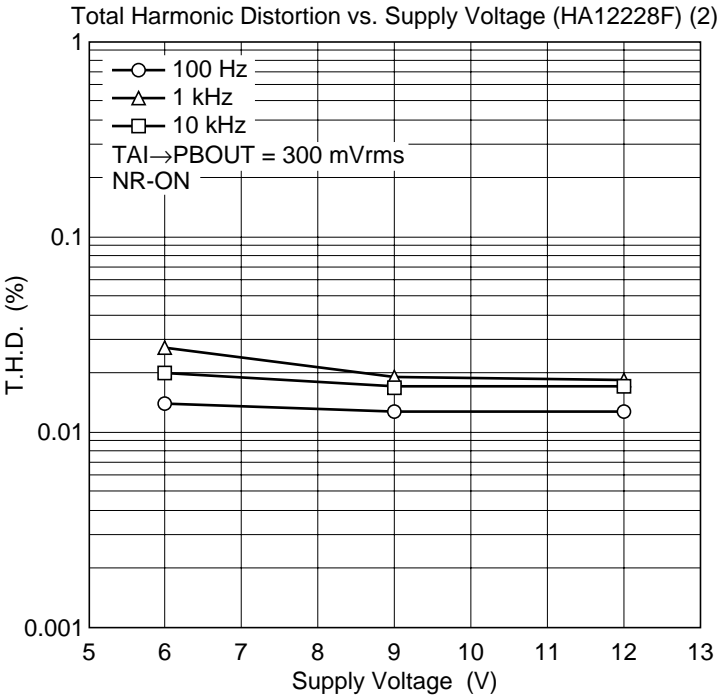

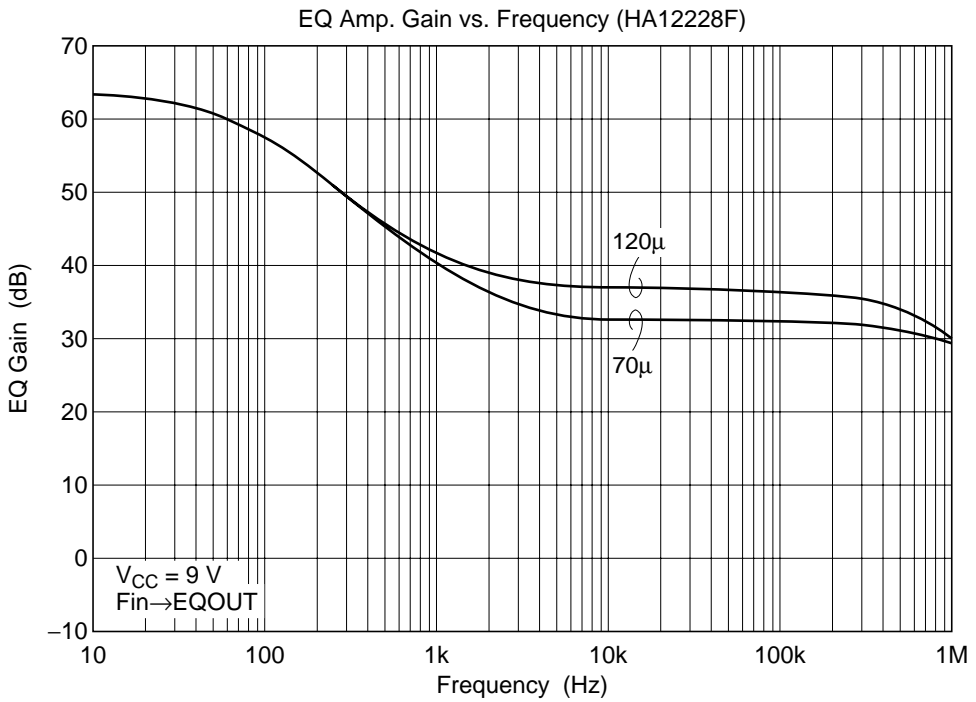
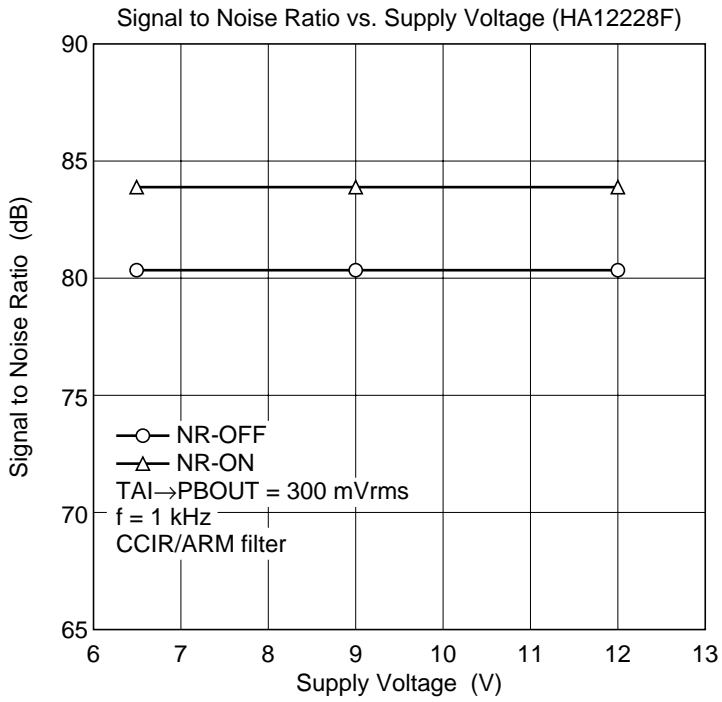

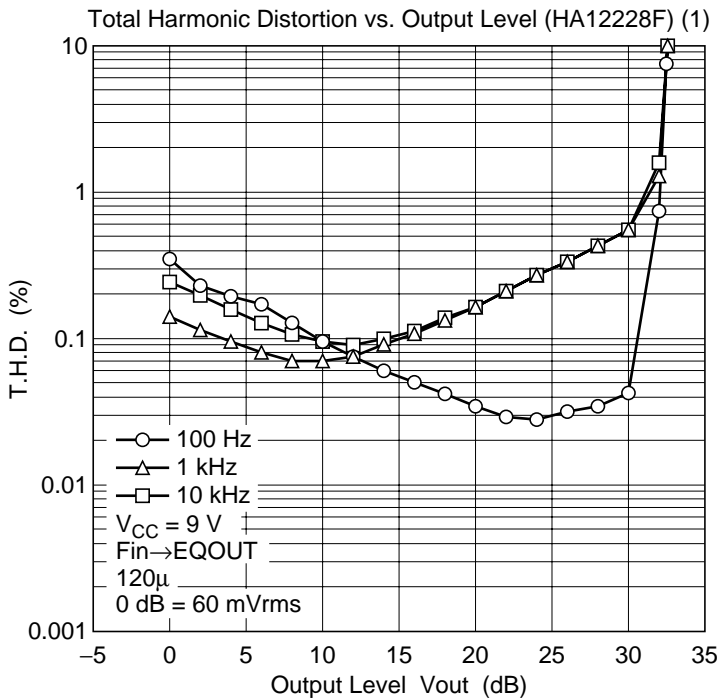
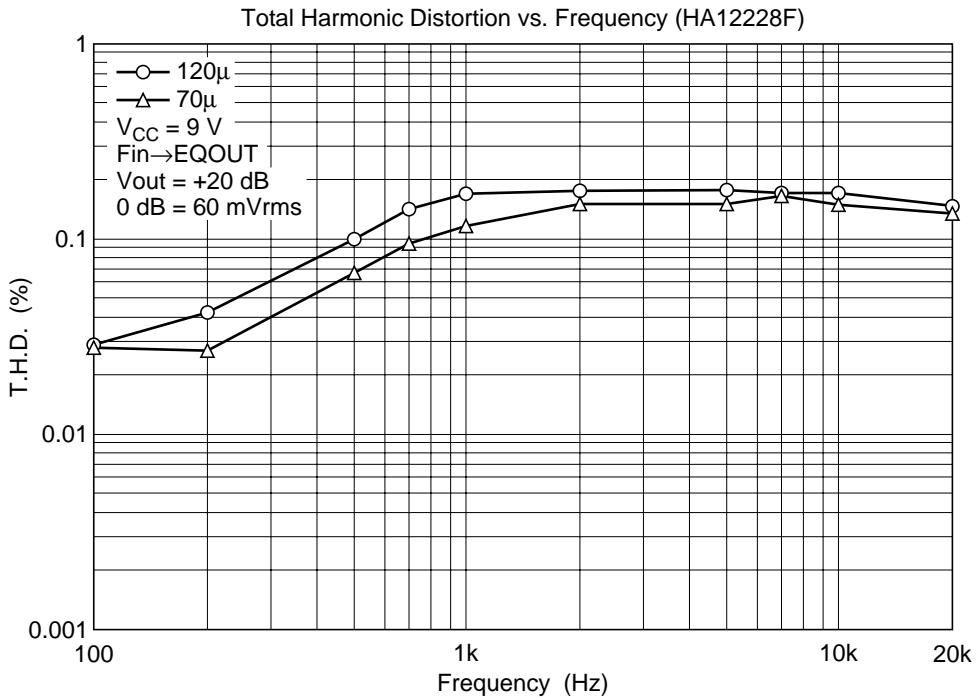

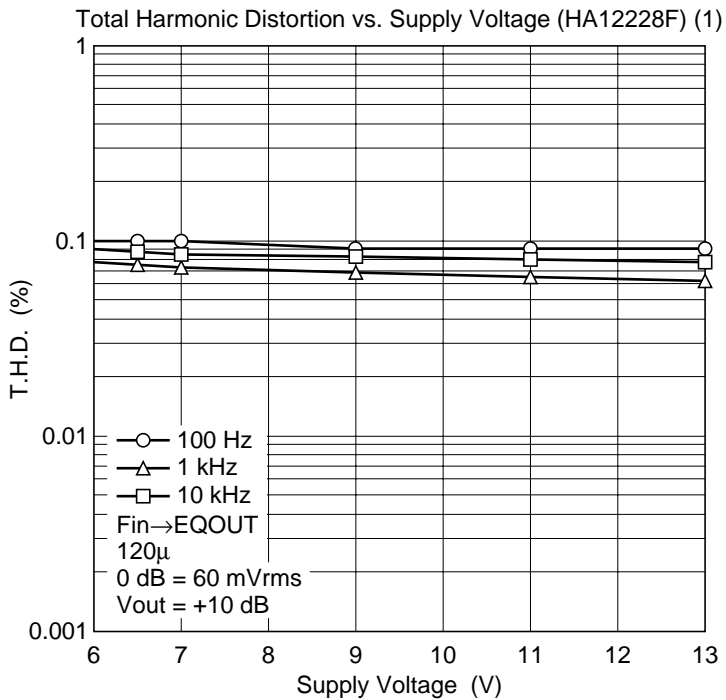
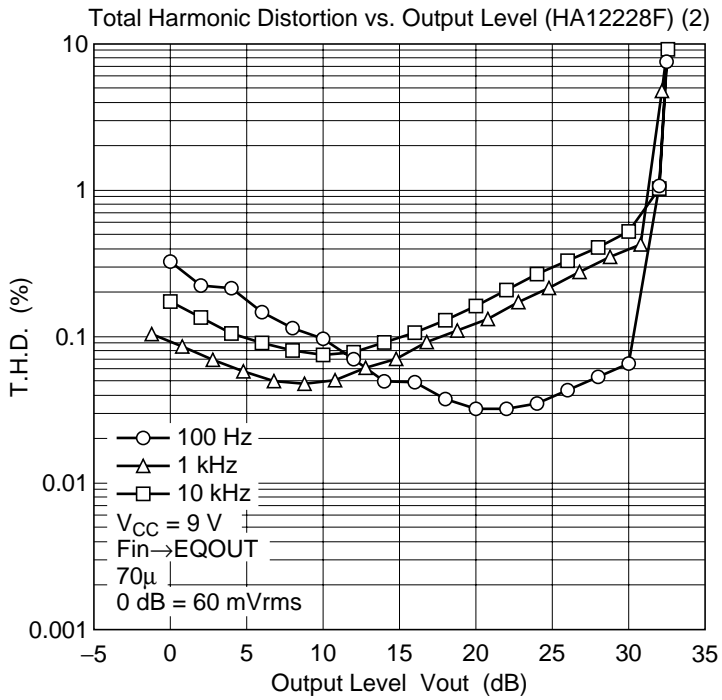

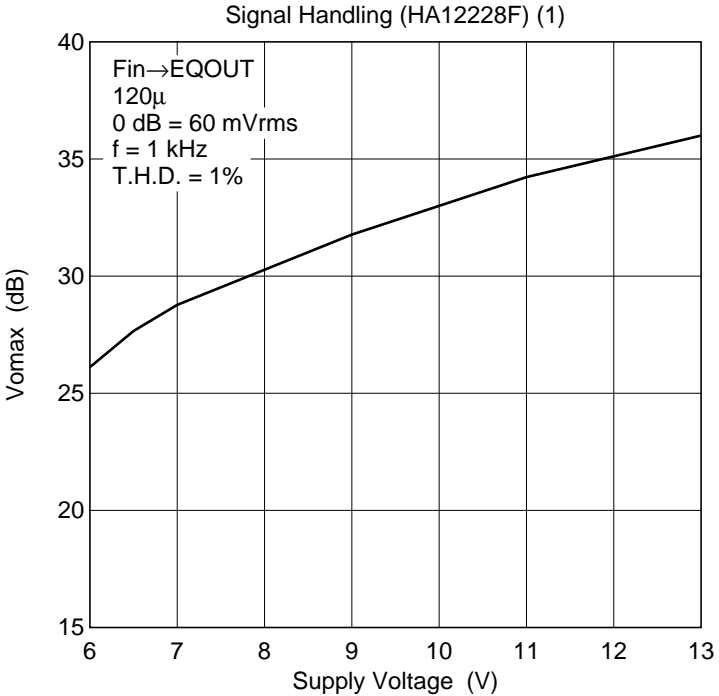
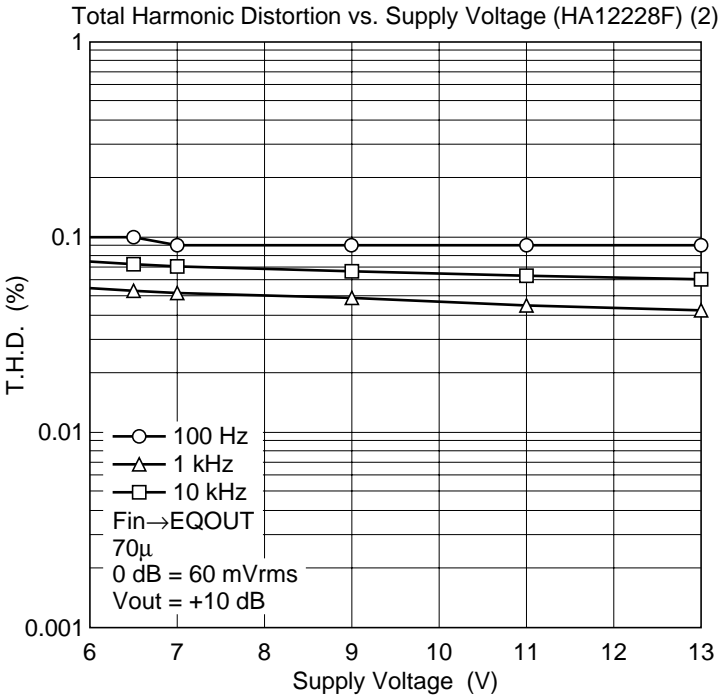

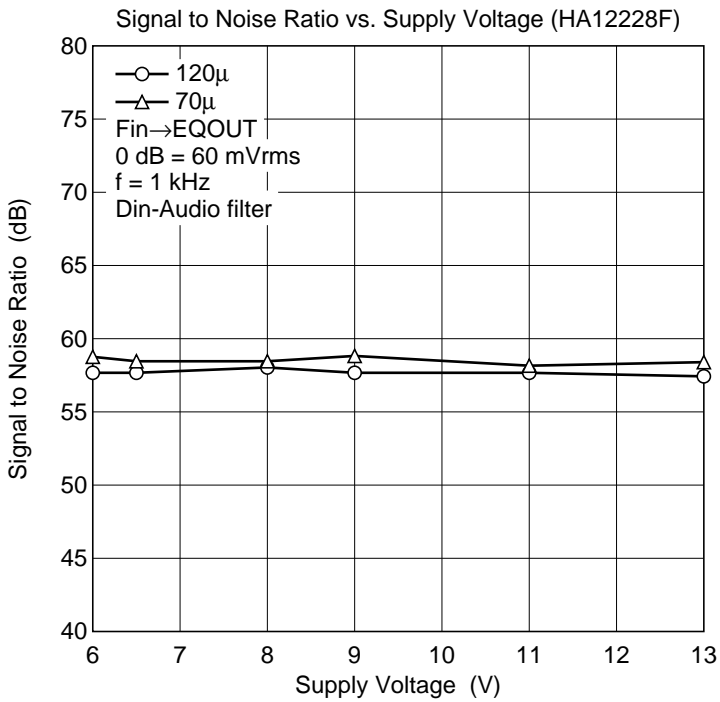
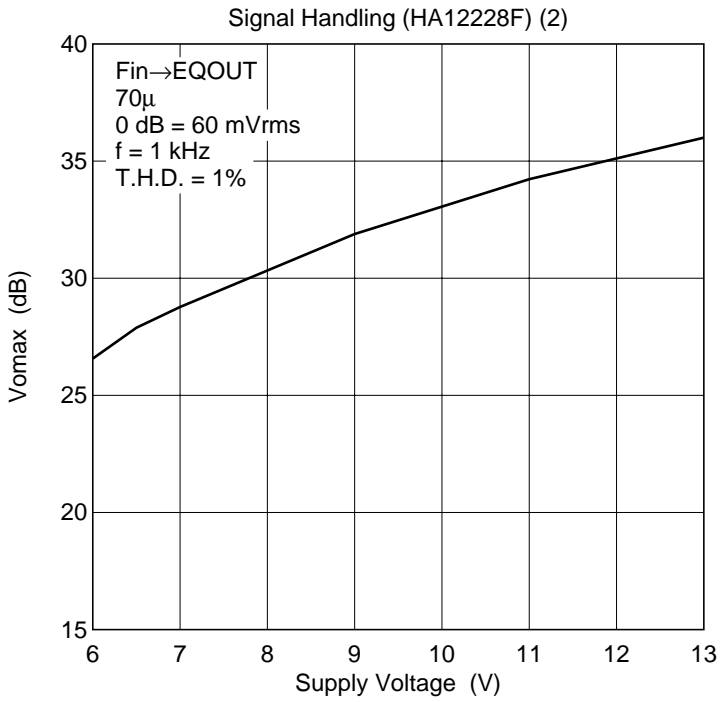

Ripple Rejection Ratio vs. Frequency (HA12228F) (1)

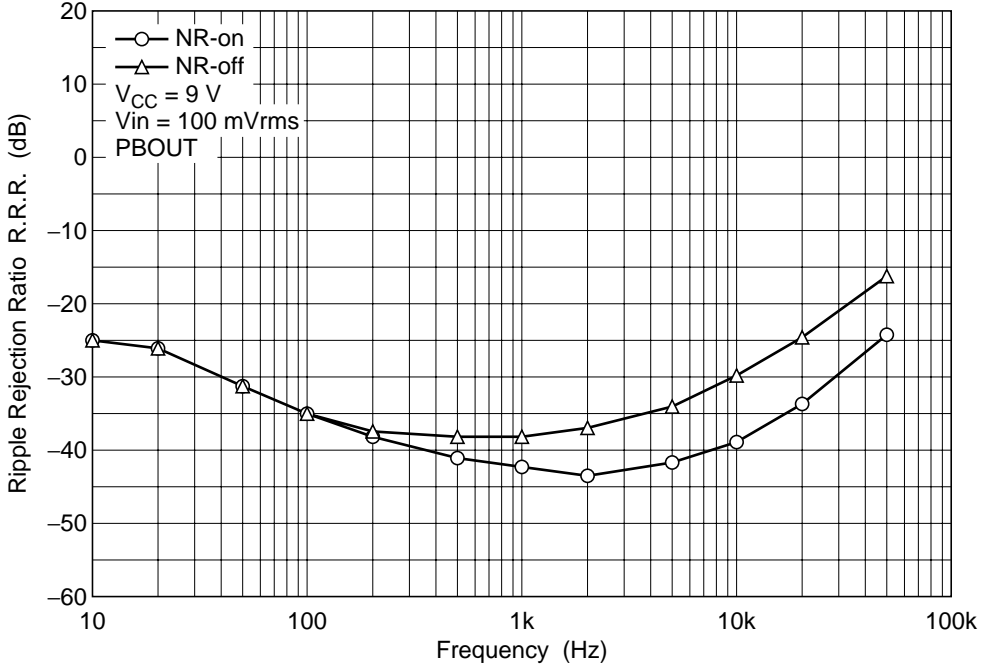

Ripple Rejection Ratio vs. Frequency (HA12228F) (2)

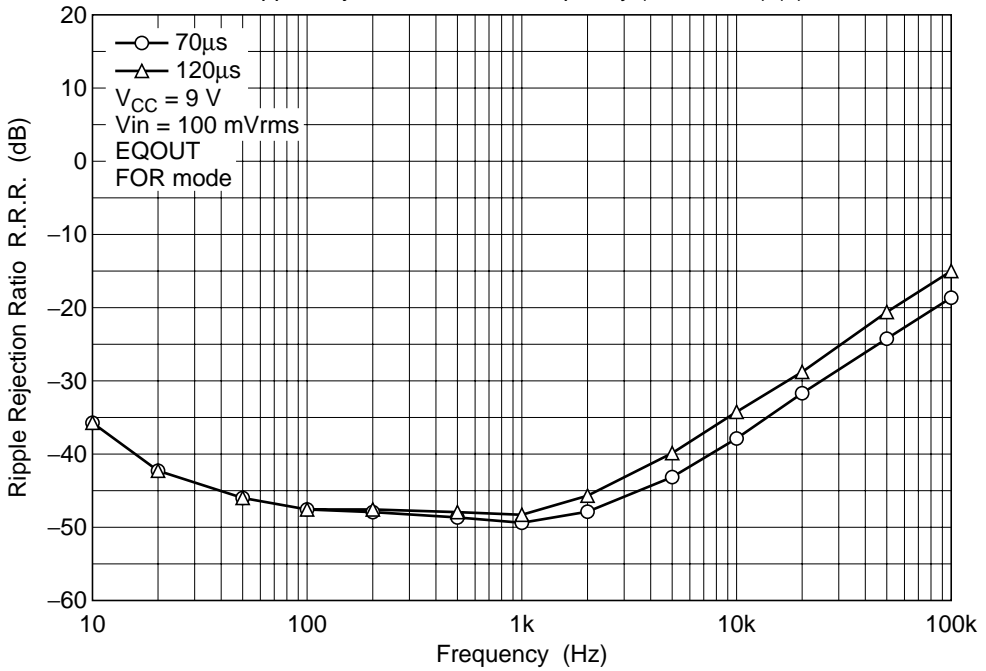

Channel Separation vs. Frequency (HA12228F) (1)

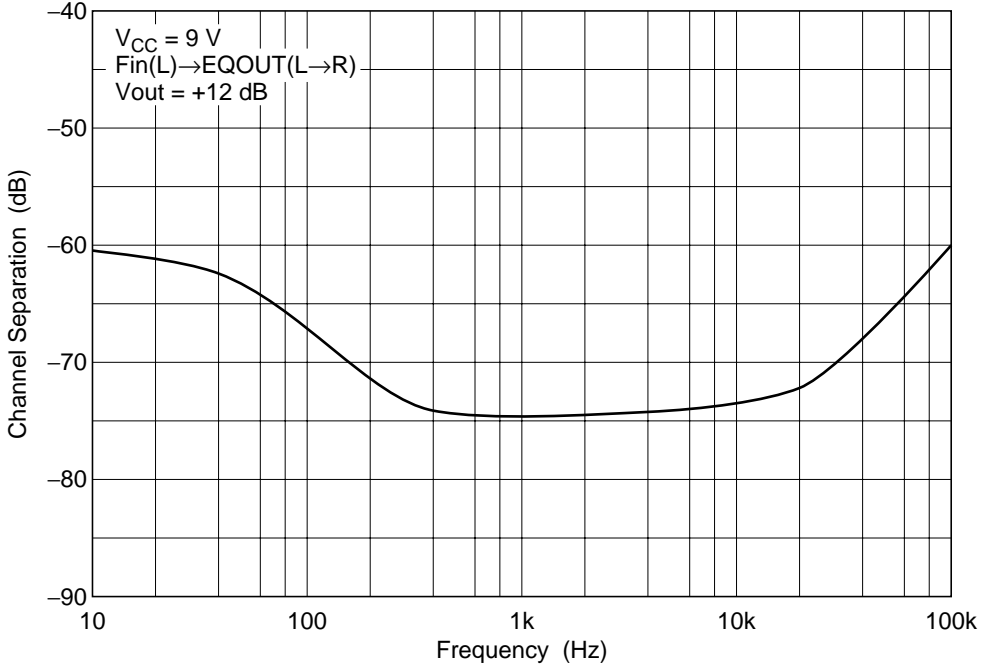

Channel Separation vs. Frequency (HA12228F) (2)

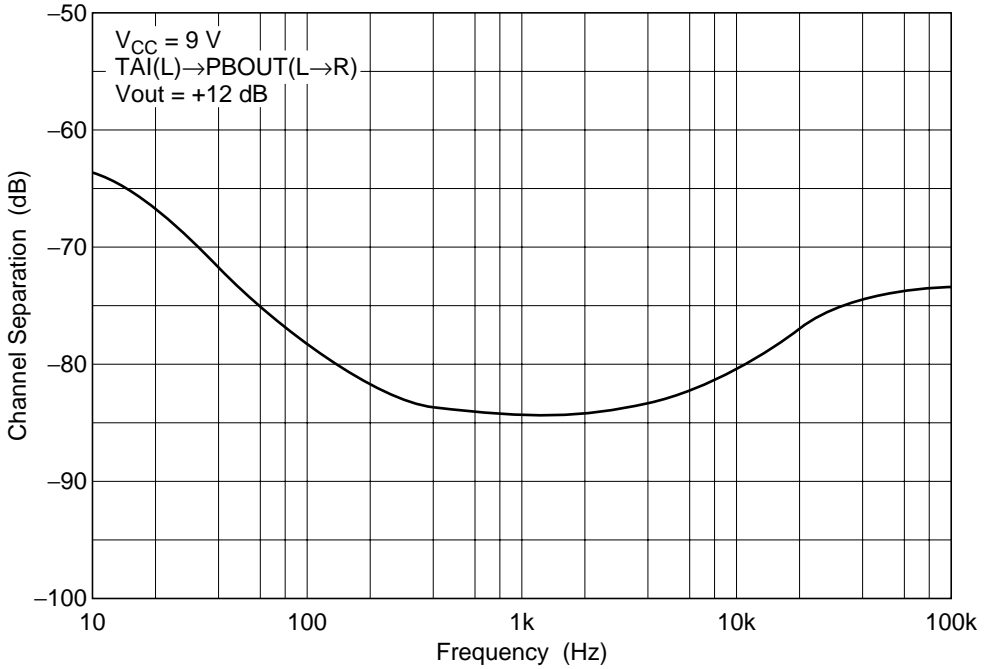

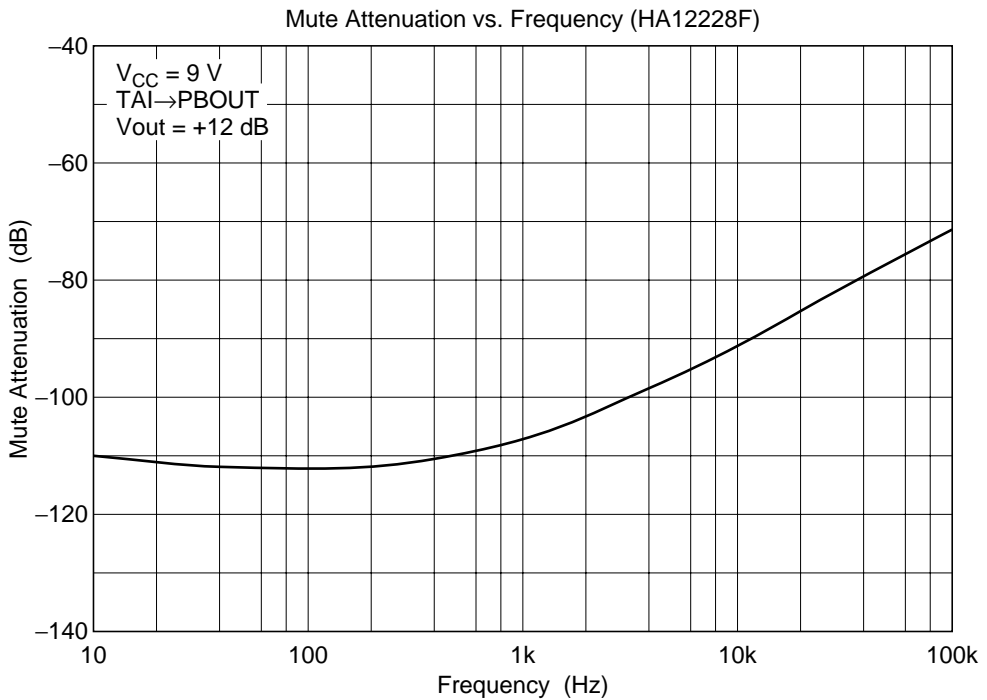
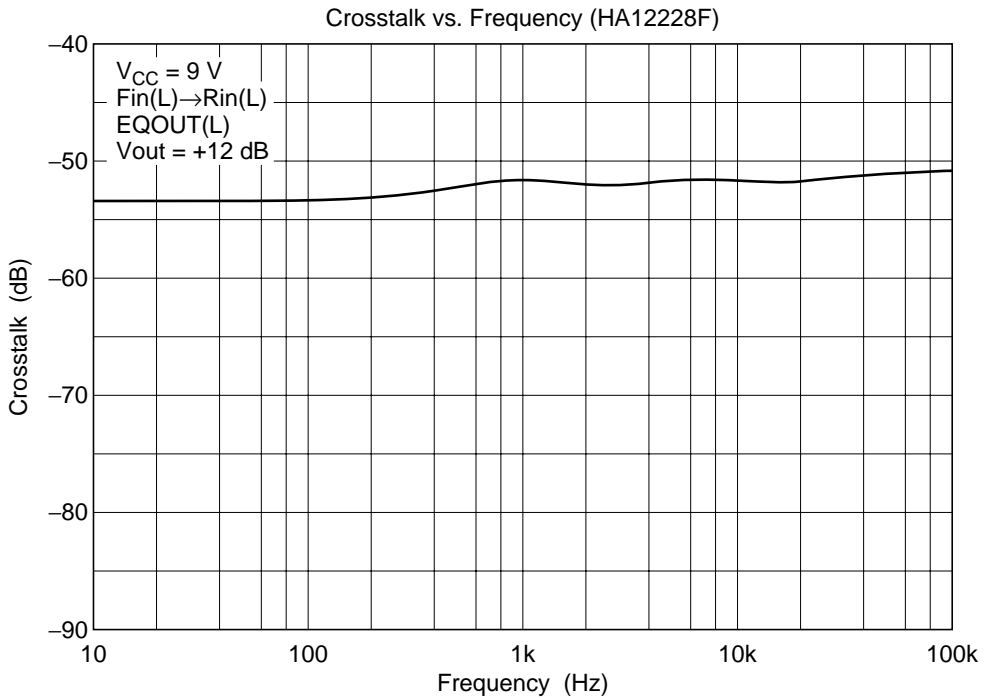

HA12228F/HA12229F

MS Amp. Gain vs. Frequency (HA12228F) (1)

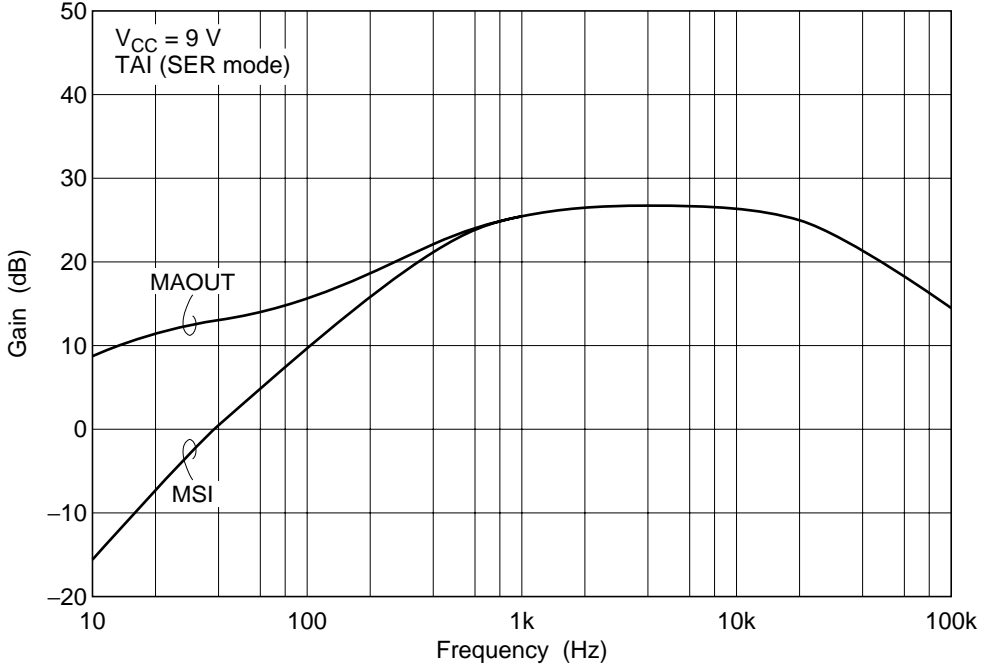

MS Amp. Gain vs. Frequency (HA12228F) (2)

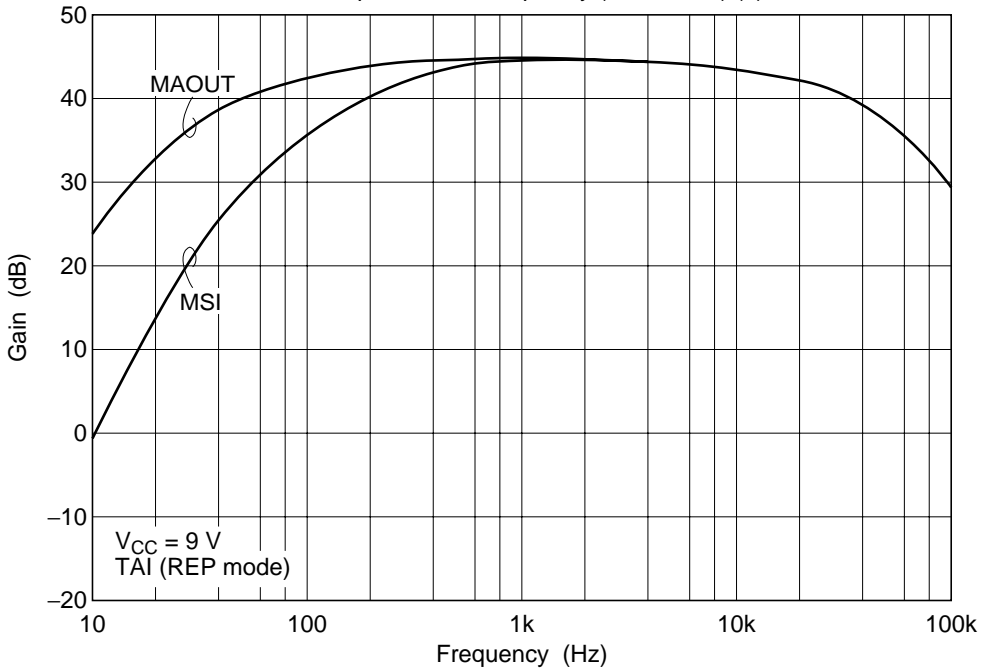

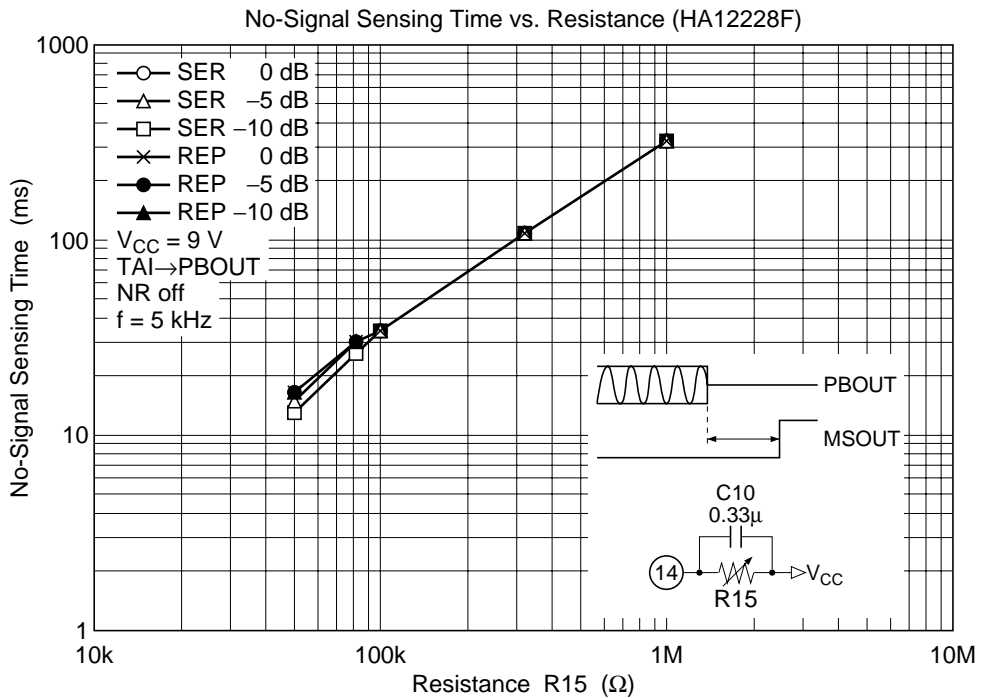
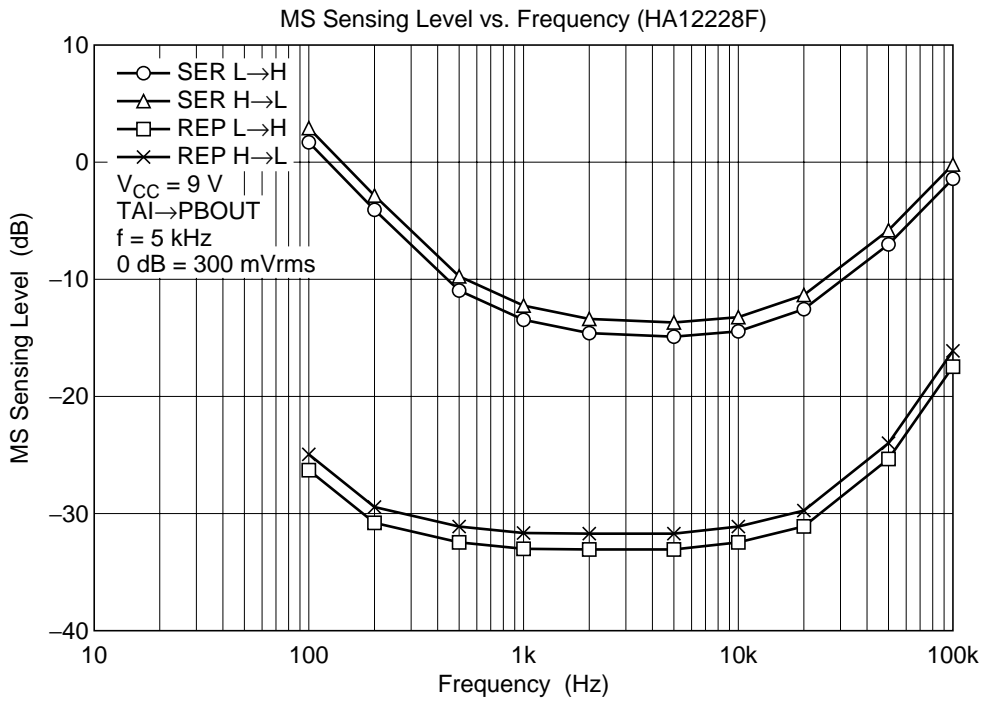

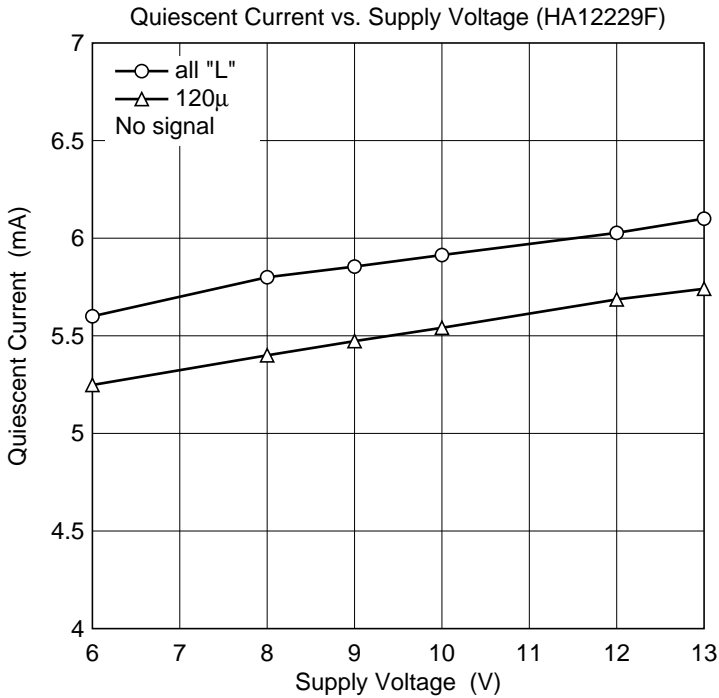
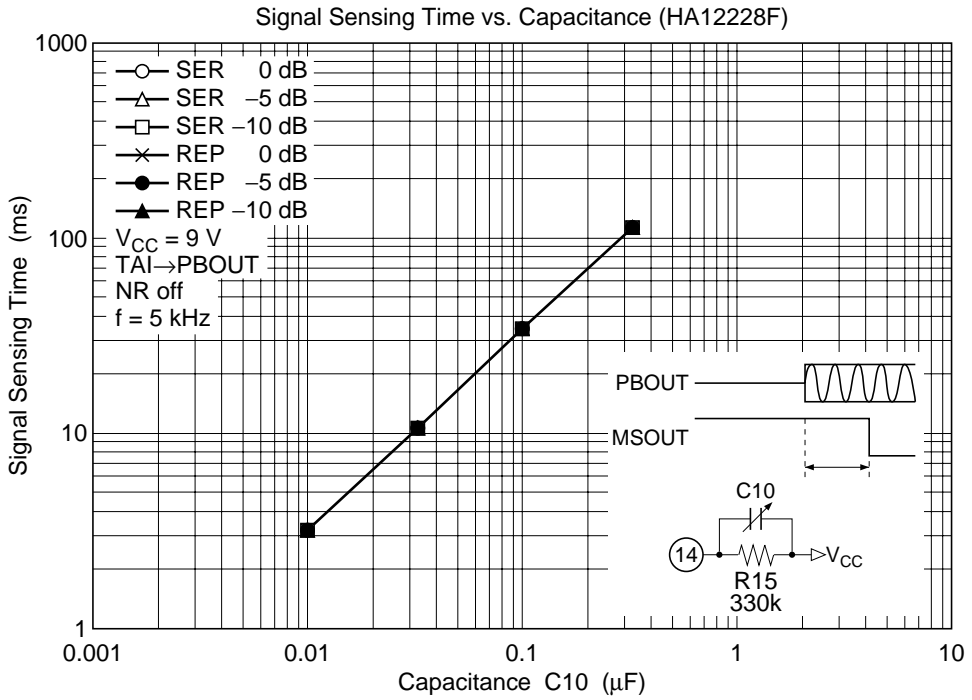

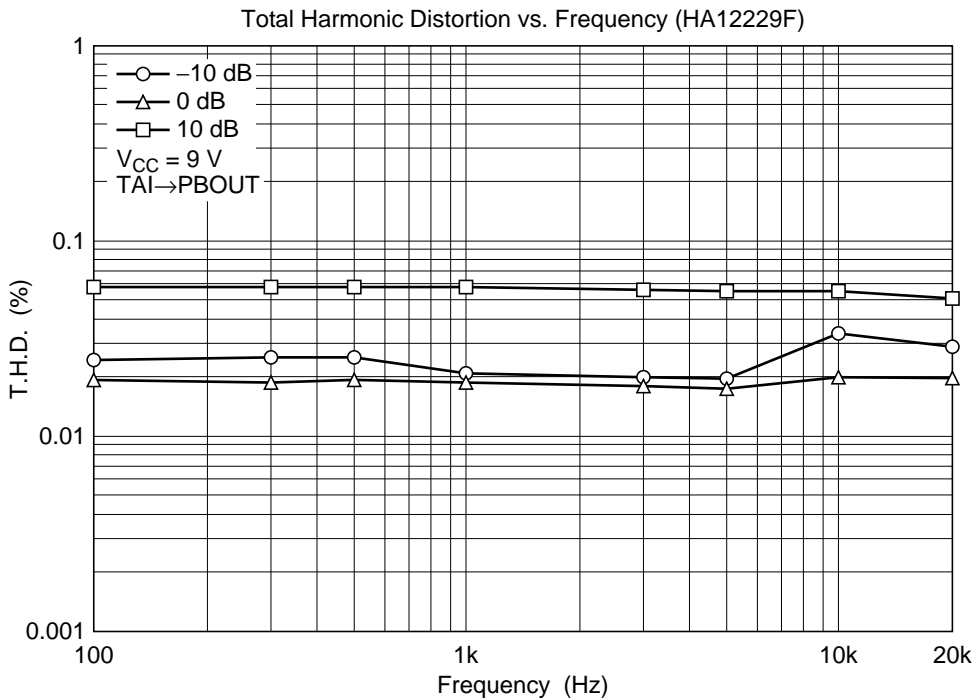
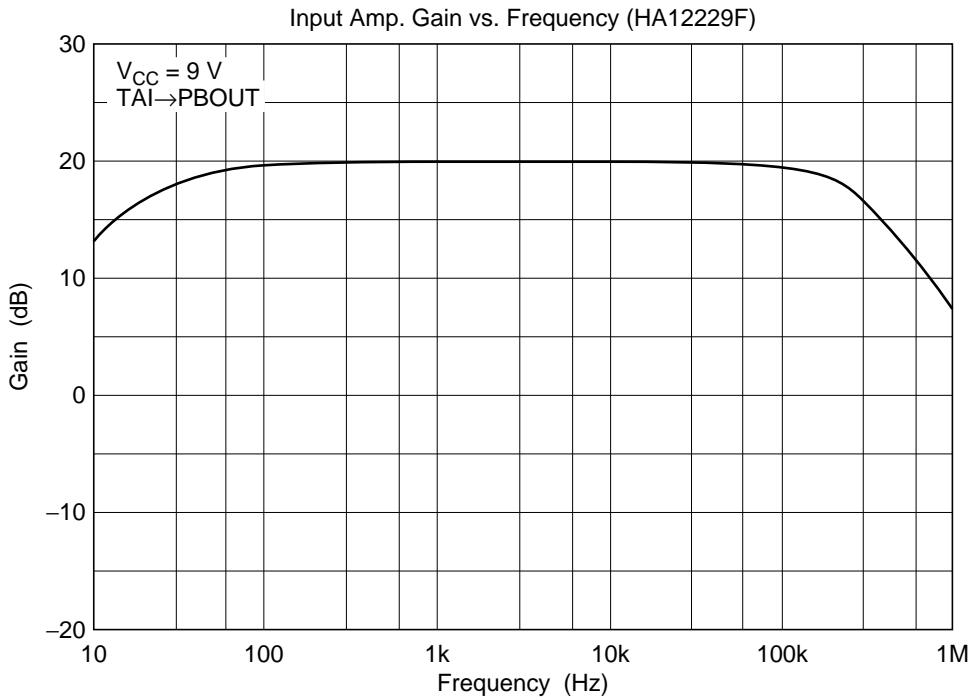

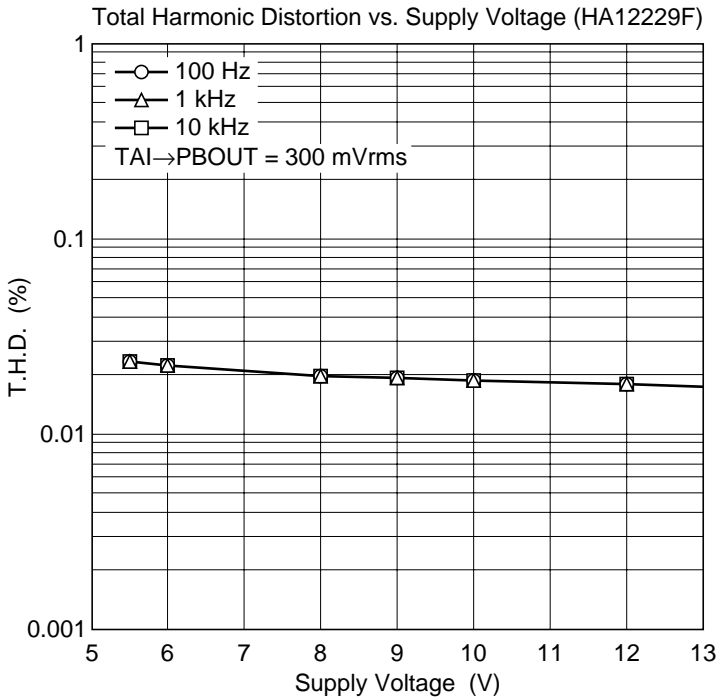
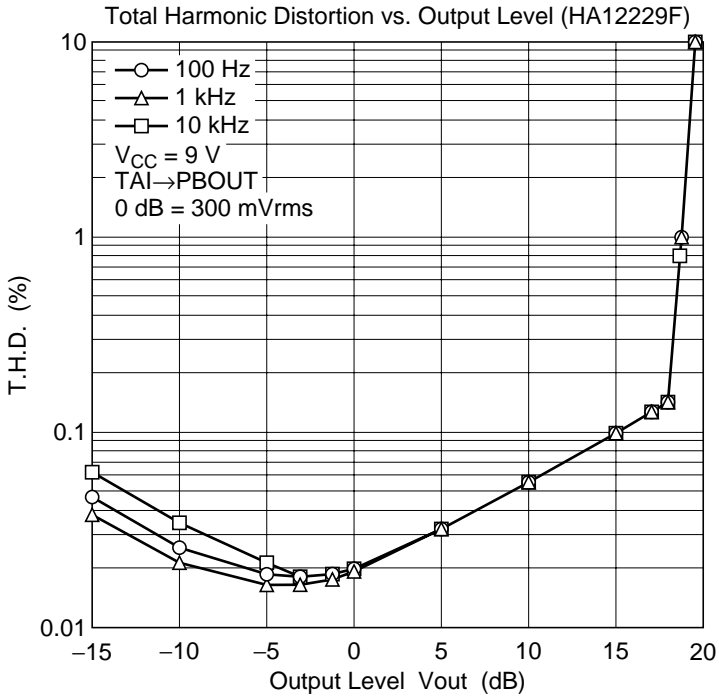

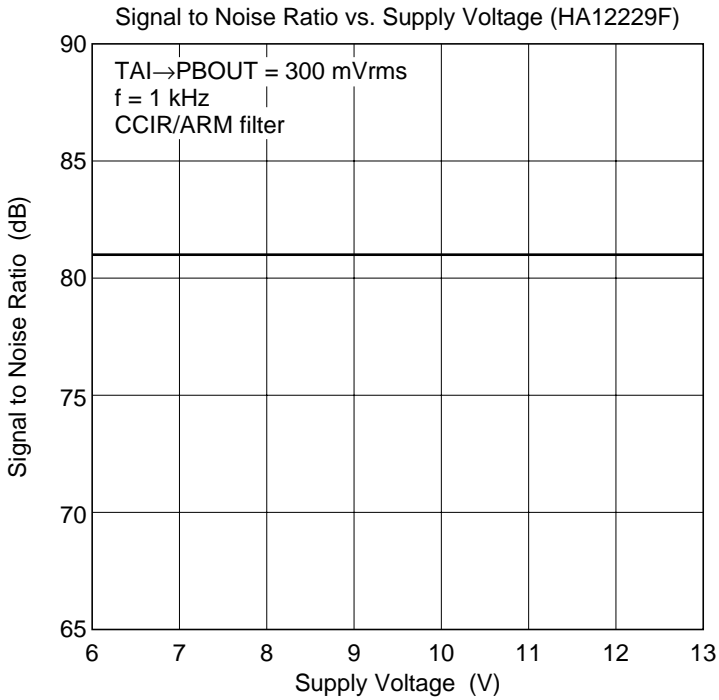
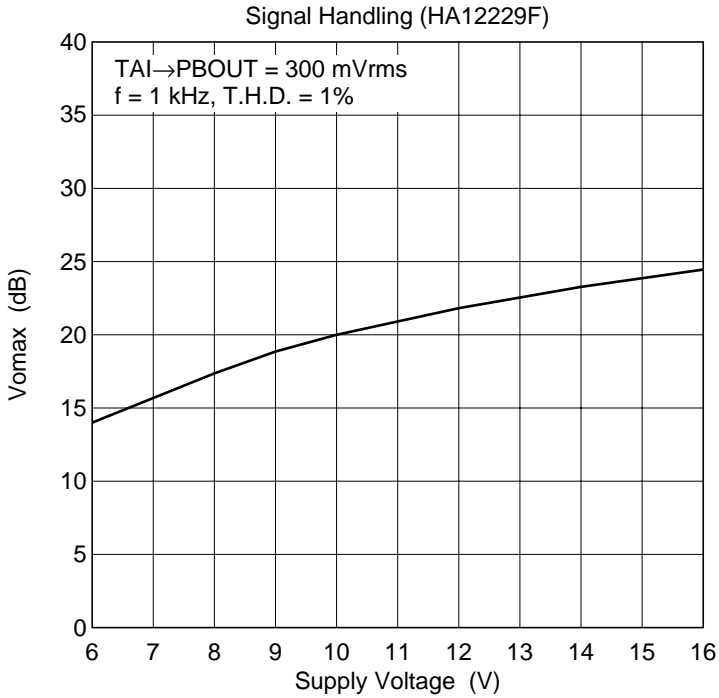

EQ Amp. Gain vs. Frequency (HA12229F)

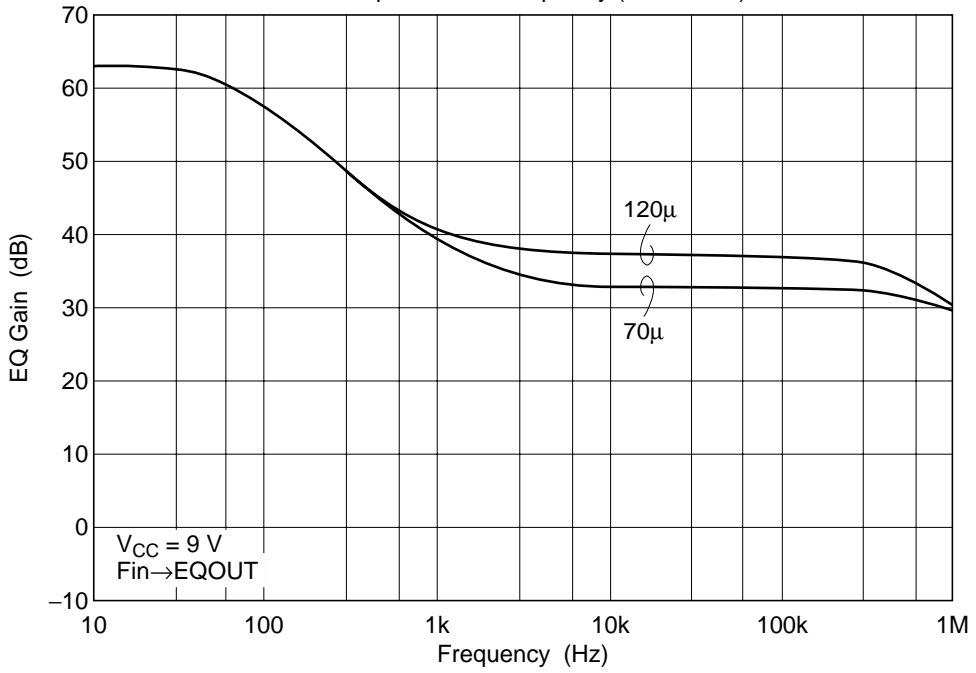

Total Harmonic Distortion vs. Frequency (HA12229F)

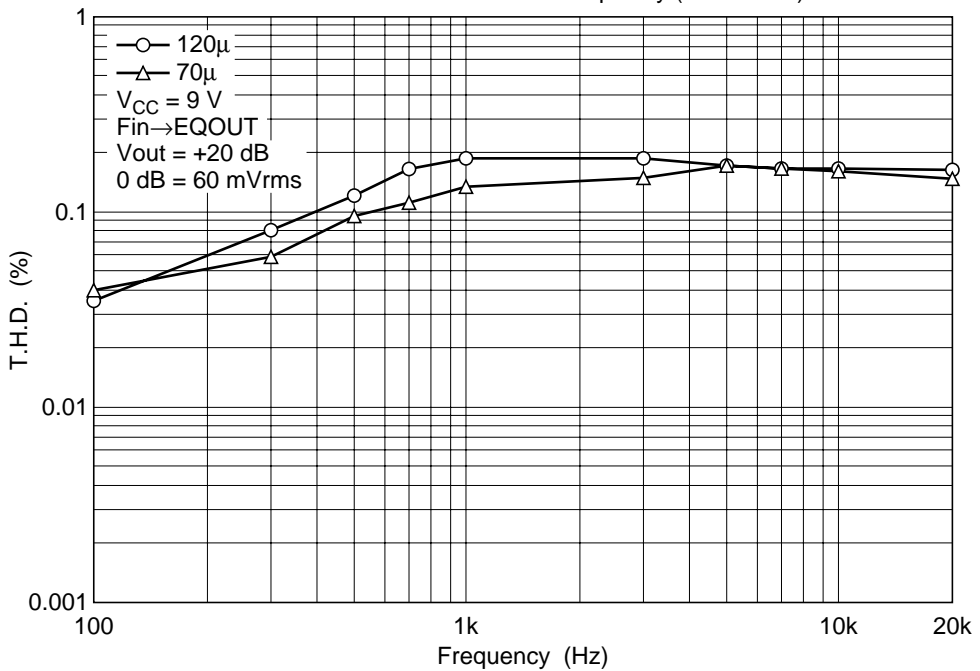

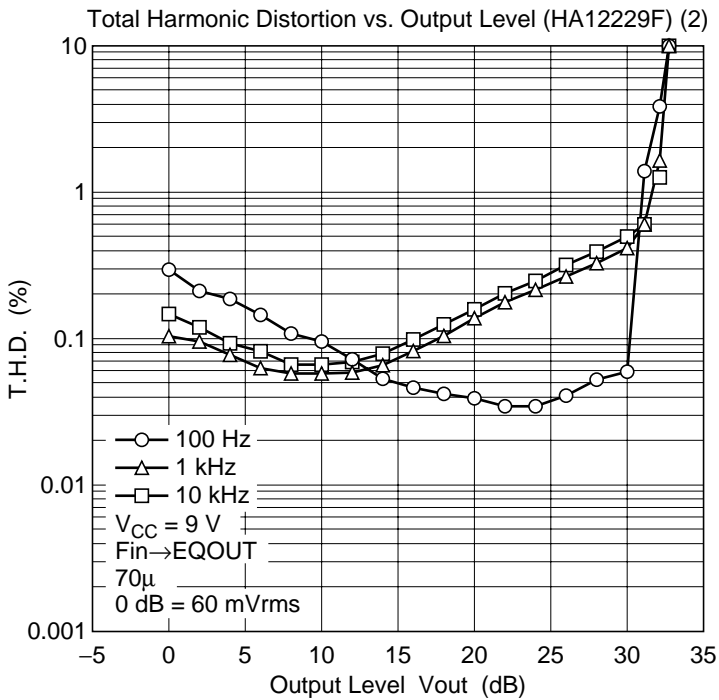
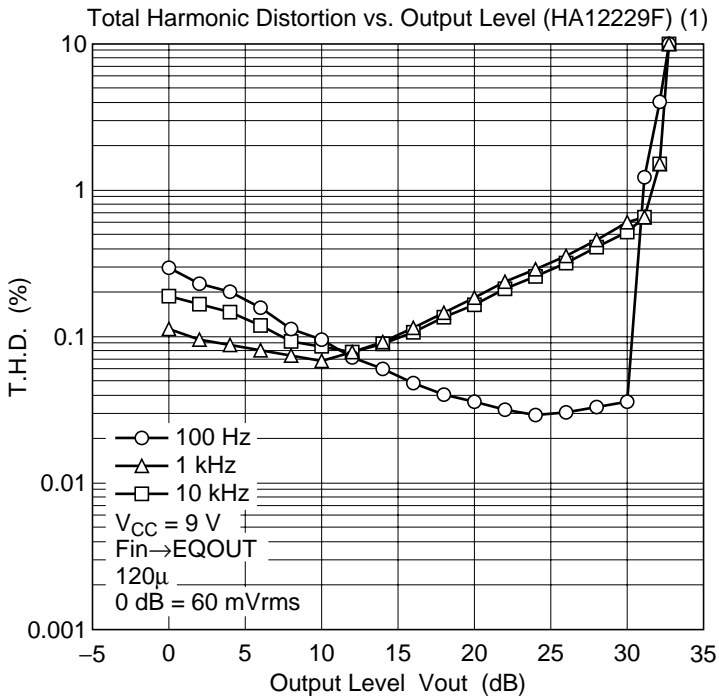

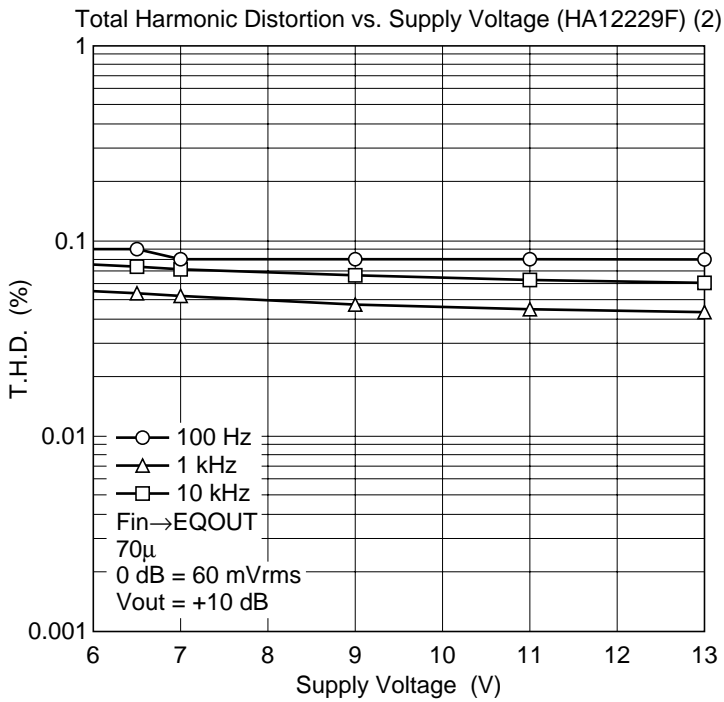
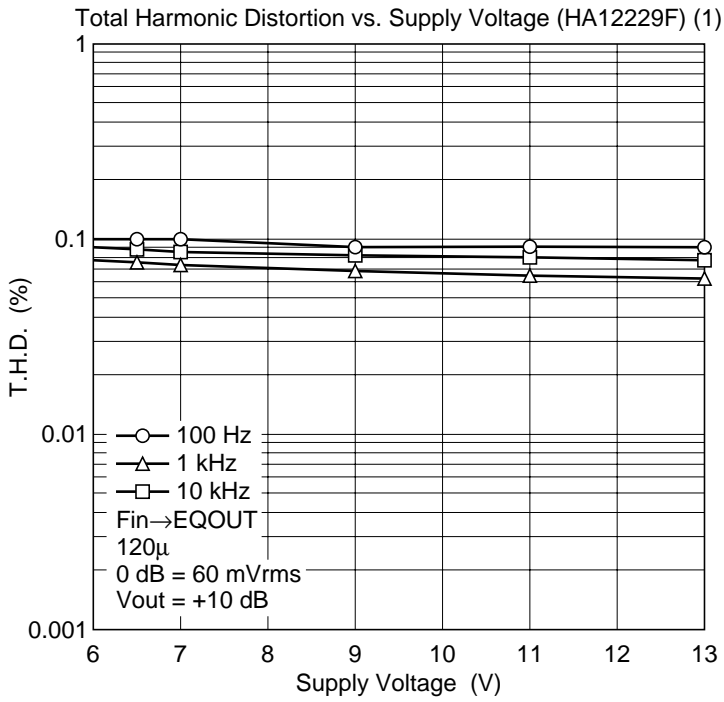

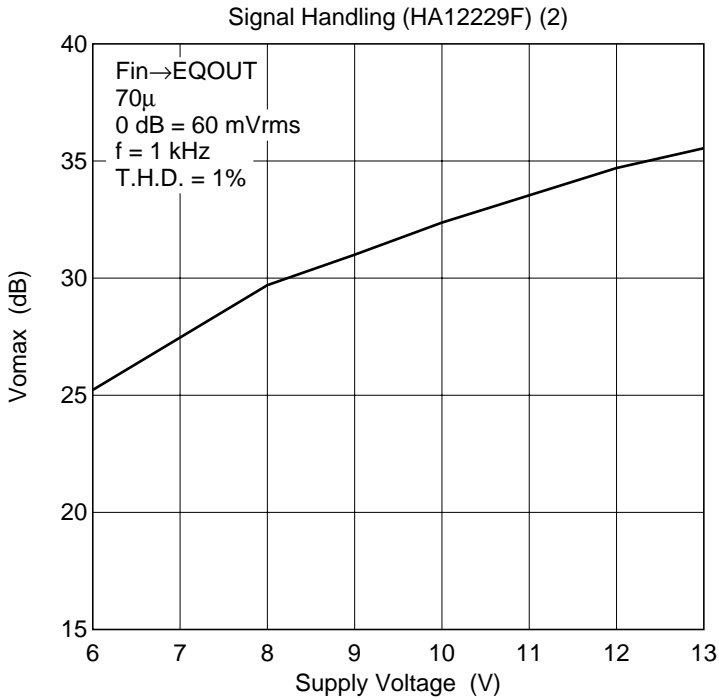
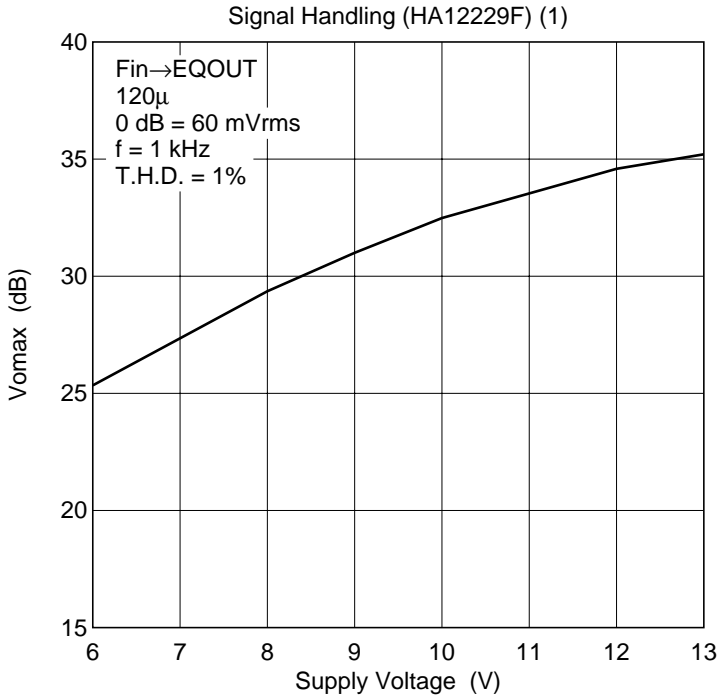

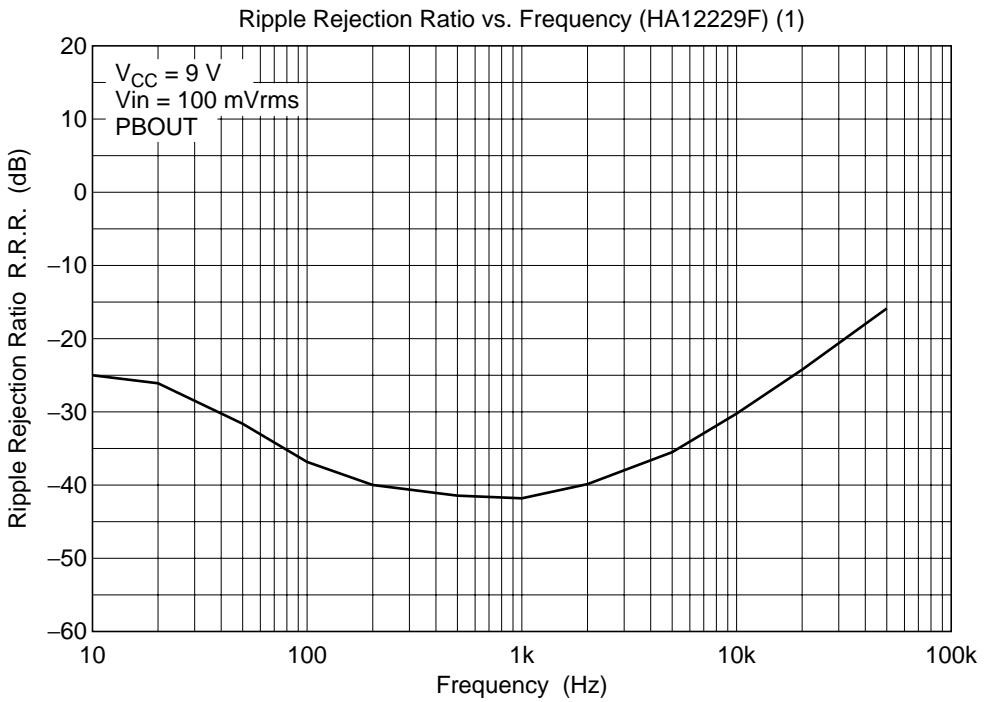
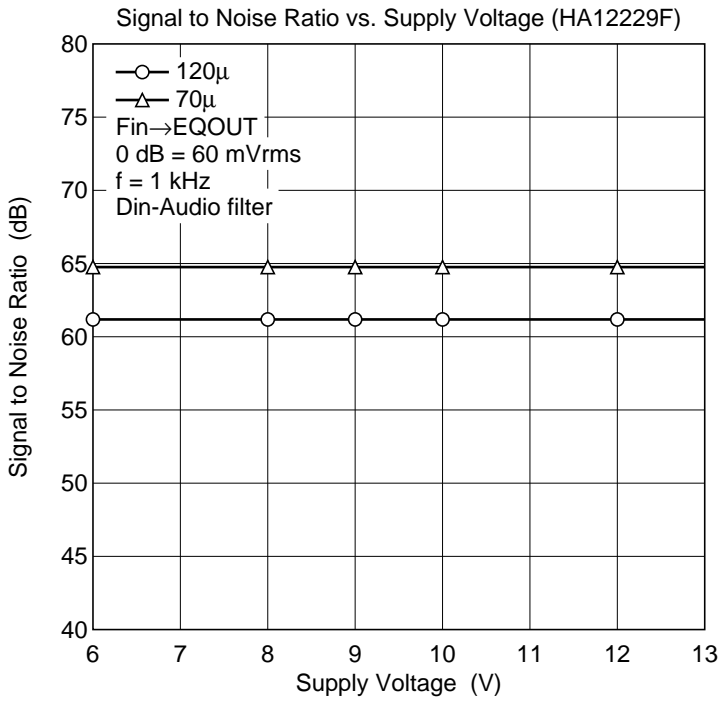

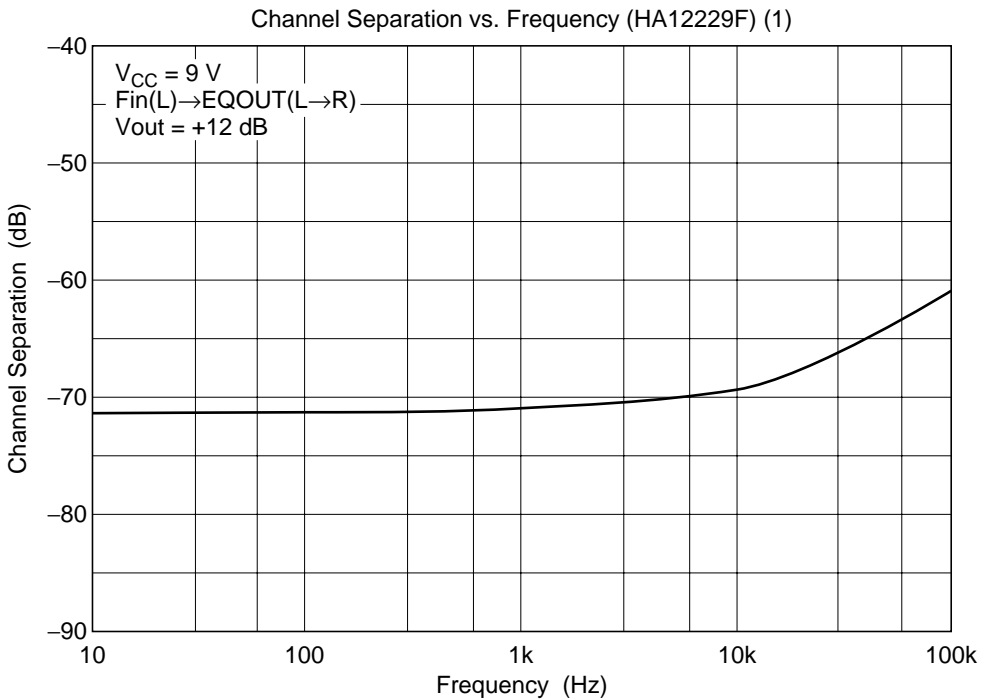
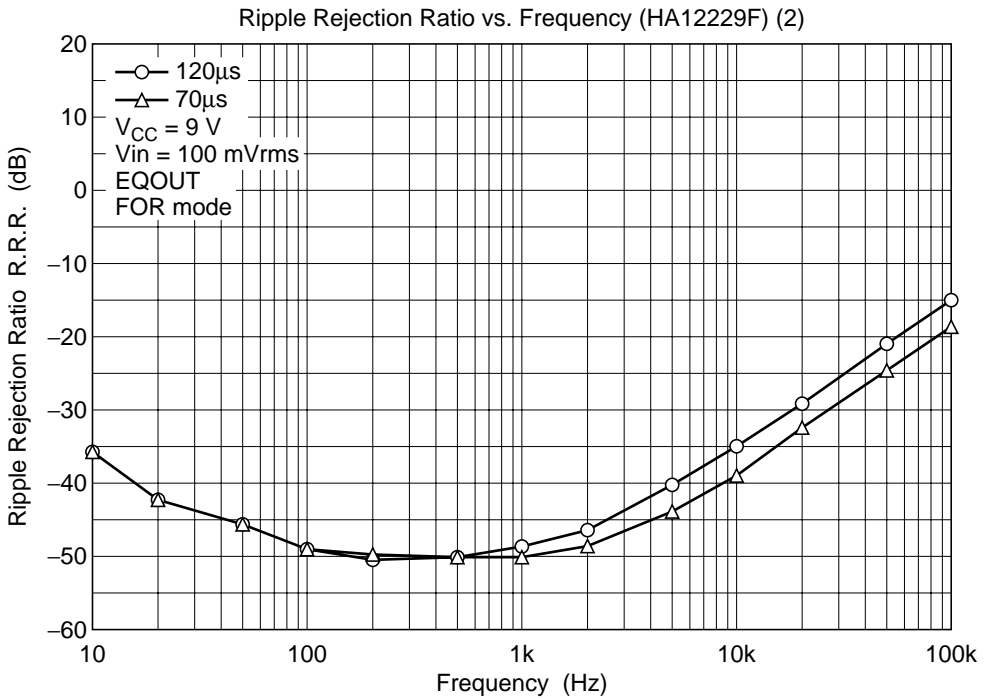

HA12228F/HA12229F

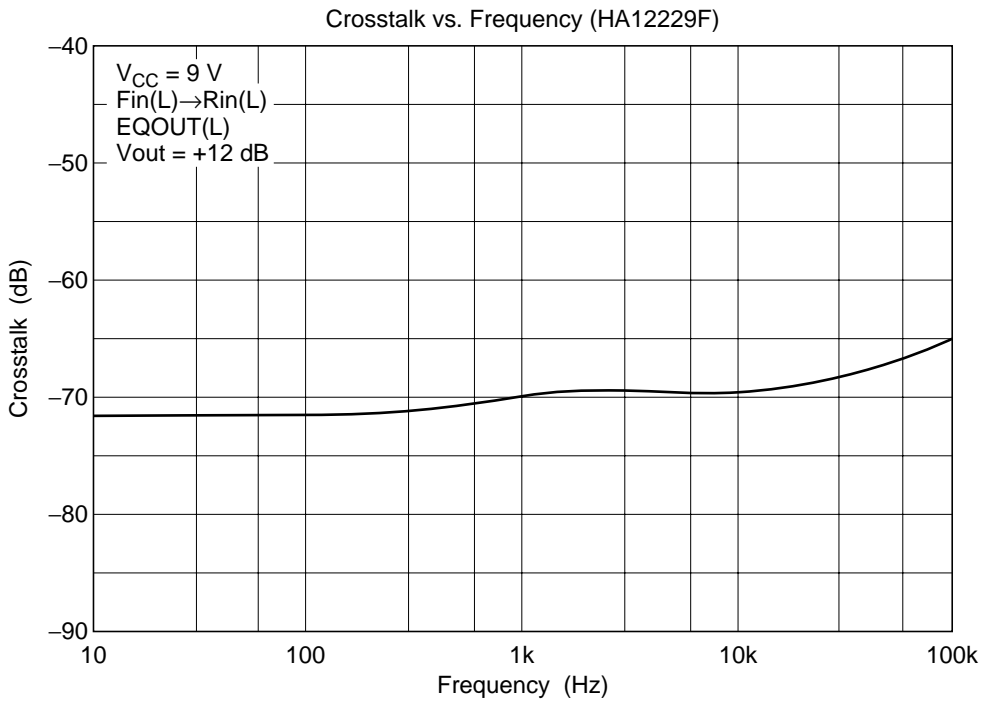
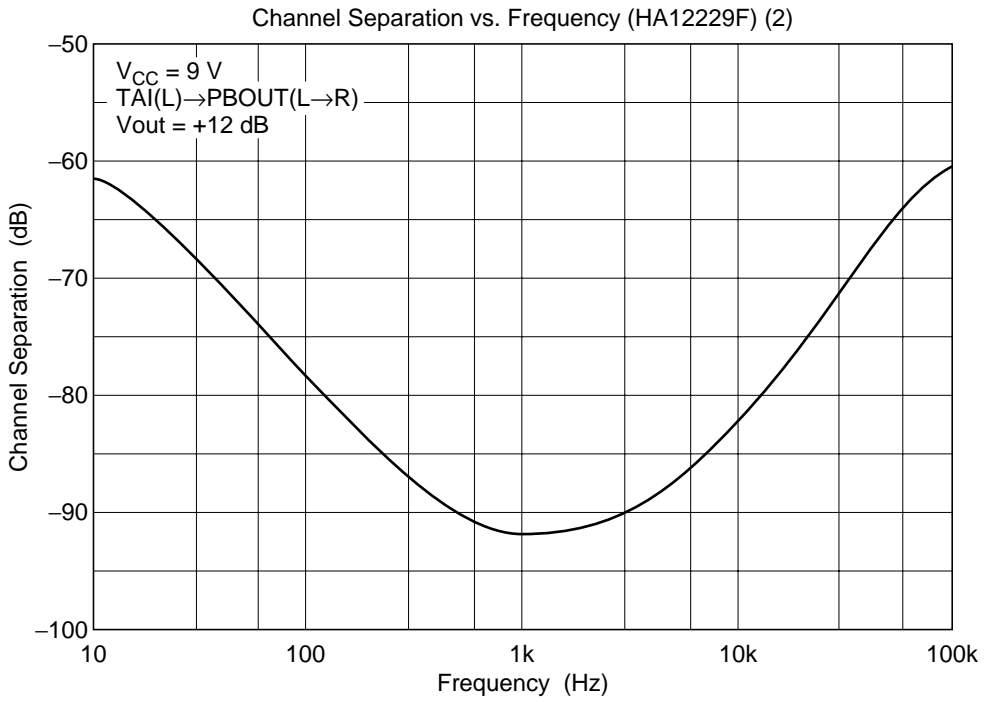

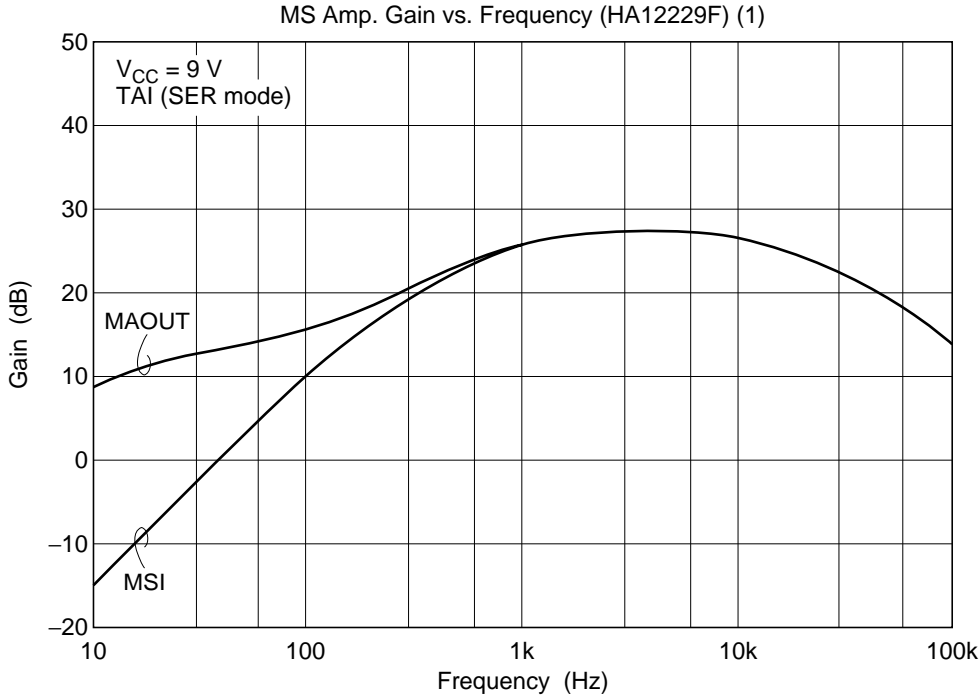
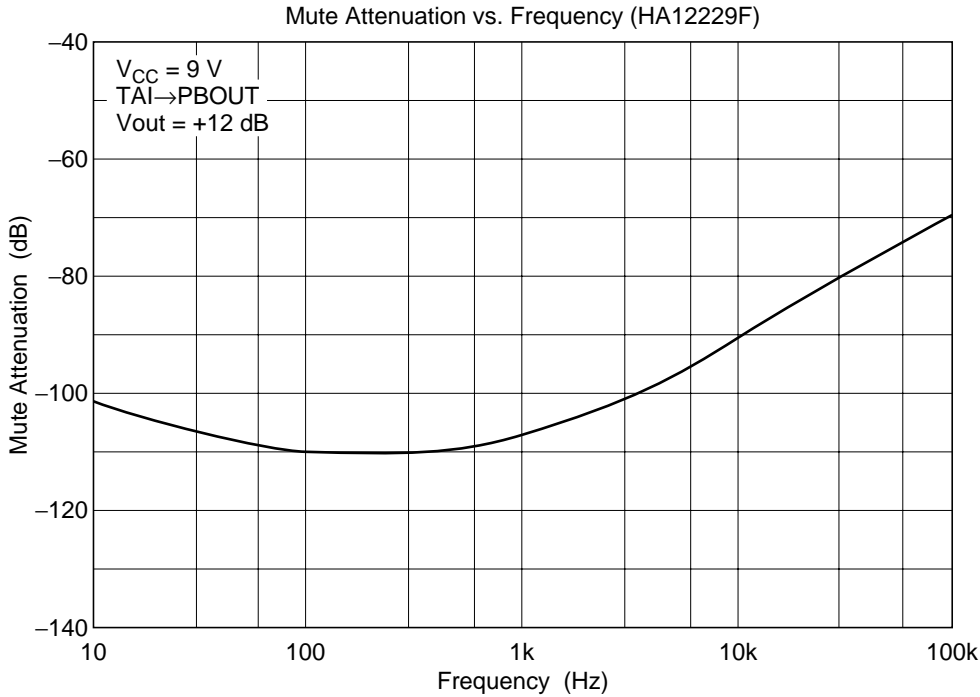

MS Amp. Gain vs. Frequency (HA12229F) (2)

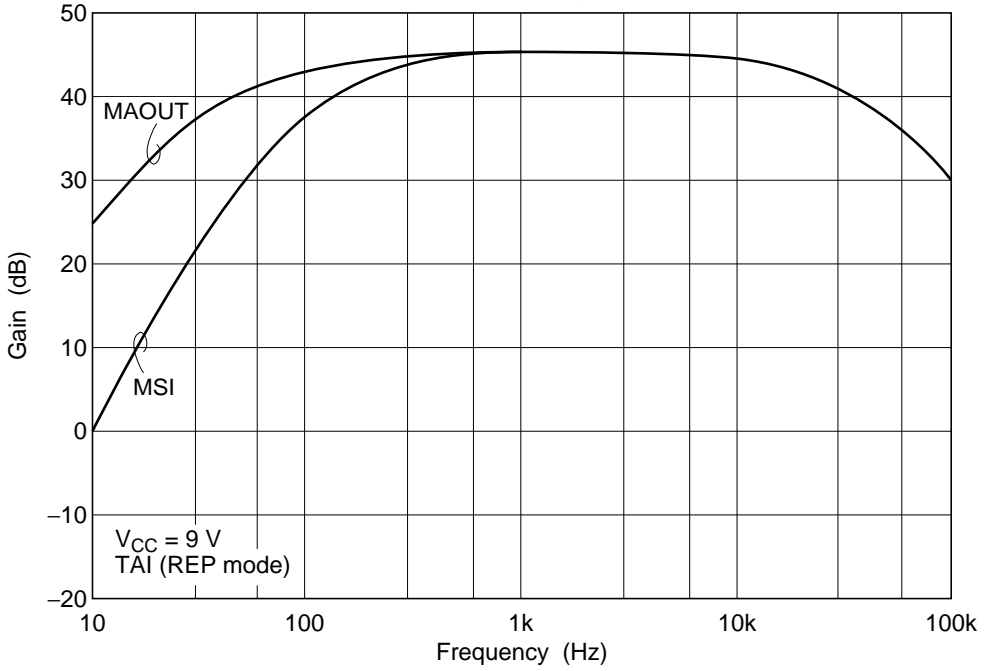

MS Sensing Level vs. Frequency (HA12229F)

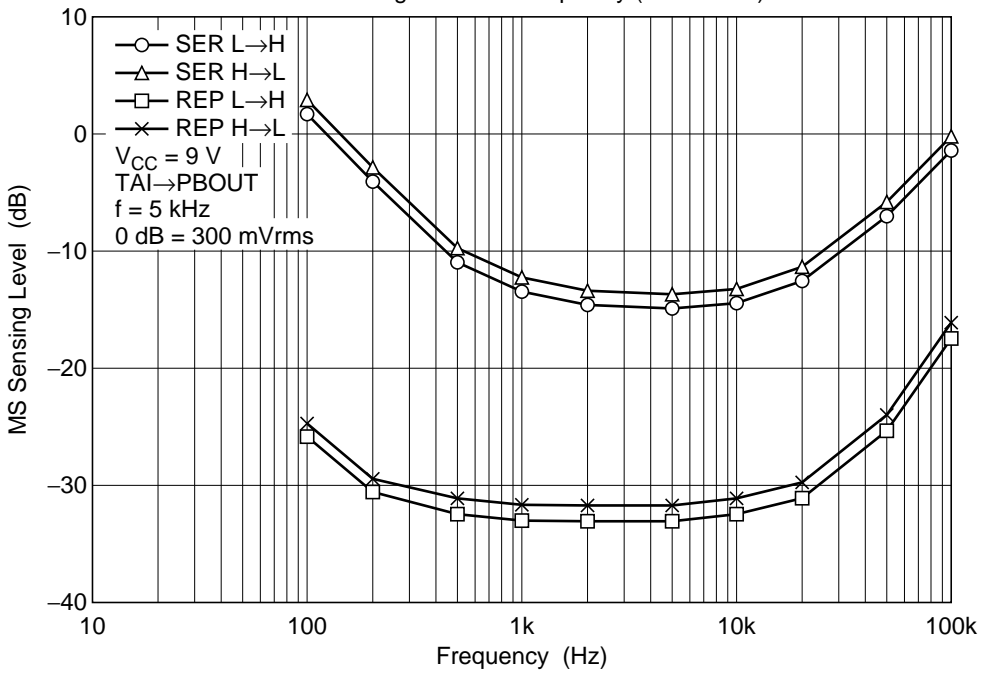

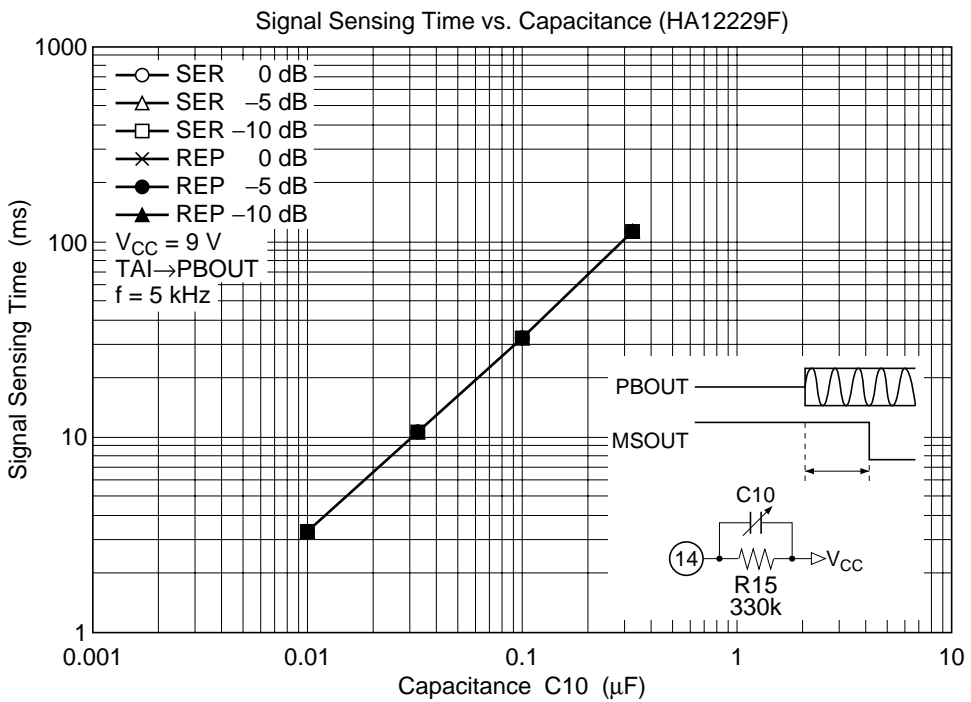
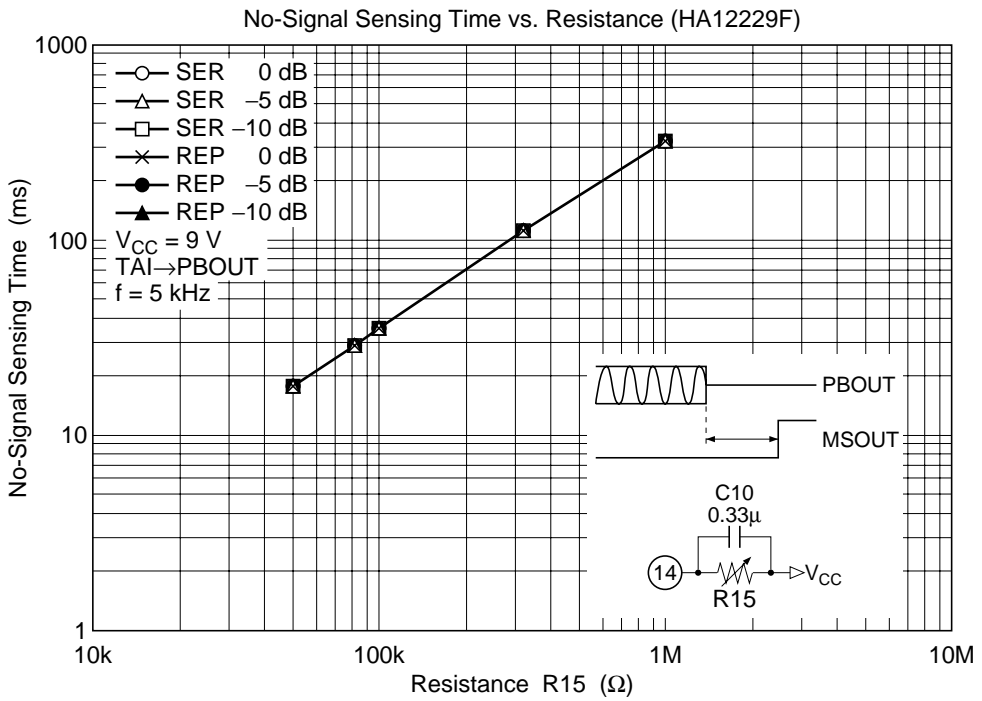

HA12228F/HA12229F

Package Dimensions

Unit: mm

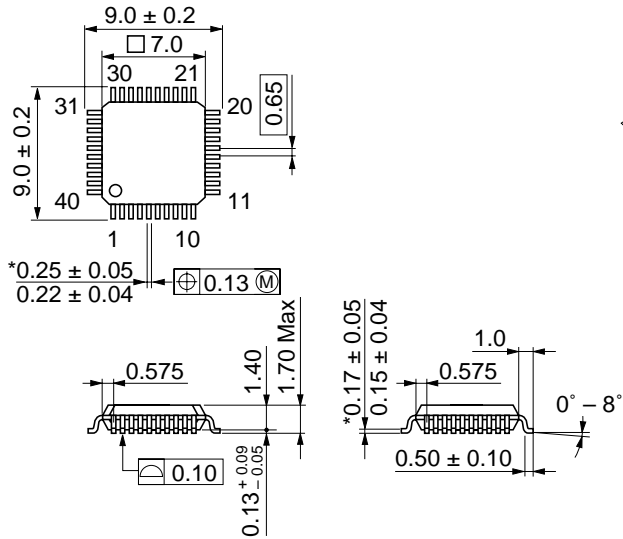

*Dimension including the plating thickness
Base material dimension

Hitachi Code	FP-40B
JEDEC	—
EIAJ	Conforms
Mass (reference value)	0.2 g

Disclaimer

1. Hitachi neither warrants nor grants licenses of any rights of Hitachi's or any third party's patent, copyright, trademark, or other intellectual property rights for information contained in this document. Hitachi bears no responsibility for problems that may arise with third party's rights, including intellectual property rights, in connection with use of the information contained in this document.
2. Products and product specifications may be subject to change without notice. Confirm that you have received the latest product standards or specifications before final design, purchase or use.
3. Hitachi makes every attempt to ensure that its products are of high quality and reliability. However, contact Hitachi's sales office before using the product in an application that demands especially high quality and reliability or where its failure or malfunction may directly threaten human life or cause risk of bodily injury, such as aerospace, aeronautics, nuclear power, combustion control, transportation, traffic, safety equipment or medical equipment for life support.
4. Design your application so that the product is used within the ranges guaranteed by Hitachi particularly for maximum rating, operating supply voltage range, heat radiation characteristics, installation conditions and other characteristics. Hitachi bears no responsibility for failure or damage when used beyond the guaranteed ranges. Even within the guaranteed ranges, consider normally foreseeable failure rates or failure modes in semiconductor devices and employ systemic measures such as fail-safes, so that the equipment incorporating Hitachi product does not cause bodily injury, fire or other consequential damage due to operation of the Hitachi product.
5. This product is not designed to be radiation resistant.
6. No one is permitted to reproduce or duplicate, in any form, the whole or part of this document without written approval from Hitachi.
7. Contact Hitachi's sales office for any questions regarding this document or Hitachi semiconductor products.

Sales Offices

HITACHI

Hitachi, Ltd.

Semiconductor & Integrated Circuits.
 Nippon Bldg., 2-6-2, Ohte-machi, Chiyoda-ku, Tokyo 100-0004, Japan
 Tel: Tokyo (03) 3270-2111 Fax: (03) 3270-5109

URL NorthAmerica : <http://semiconductor.hitachi.com/>
 Europe : <http://www.hitachi-eu.com/hel/ecg>
 Asia : <http://sicapac.hitachi-asia.com>
 Japan : <http://www.hitachi.co.jp/Sicd/indx.htm>

For further information write to:

Hitachi Semiconductor
 (America) Inc.
 179 East Tasman Drive,
 San Jose, CA 95134
 Tel: <1>(408) 433-1990
 Fax: <1>(408) 433-0223

Hitachi Europe GmbH
 Electronic Components Group
 Dornacher Straße 3
 D-85622 Feldkirchen, Munich
 Germany
 Tel: <49> (89) 9 9180-0
 Fax: <49> (89) 9 29 30 00

 Hitachi Europe Ltd.
 Electronic Components Group.
 Whitebrook Park
 Lower Cookham Road
 Maidenhead
 Berkshire SL6 8YA, United Kingdom
 Tel: <44> (1628) 585000
 Fax: <44> (1628) 585160

Hitachi Asia Ltd.
 Hitachi Tower
 16 Collyer Quay #20-00,
 Singapore 049318
 Tel : <65>-538-6533/538-8577
 Fax : <65>-538-6933/538-3877
 URL : <http://www.hitachi.com.sg>

Hitachi Asia Ltd.
 (Taipei Branch Office)
 4/F, No. 167, Tun Hwa North Road,
 Hung-Kuo Building,
 Taipei (105), Taiwan
 Tel : <886>-(2)-2718-3666
 Fax : <886>-(2)-2718-8180
 Telex : 23222 HAS-TP
 URL : <http://www.hitachi.com.tw>

Hitachi Asia (Hong Kong) Ltd.
 Group III (Electronic Components)
 7/F., North Tower,
 World Finance Centre,
 Harbour City, Canton Road
 Tsim Sha Tsui, Kowloon,
 Hong Kong
 Tel : <852>-(2)-735-9218
 Fax : <852>-(2)-730-0281
 URL : <http://www.hitachi.com.hk>

Copyright © Hitachi, Ltd., 2000. All rights reserved. Printed in Japan.
 Colophon 2.0