

3.3V ABT 16-bit buffer/driver (3-State)

74LVT16541A

FEATURES

- 16-bit universal bus interface
- 3-State buffers
- Output capability: +64mA/-32mA
- TTL input and output switching levels
- Input and output interface capability to systems at 5V supply
- Bus-hold data inputs eliminate the need for external pull-up resistors to hold unused inputs
- Live insertion/extraction permitted
- Power-up 3-State
- No bus current loading when output is tied to 5V bus
- Latch-up protection exceeds 500mA per JEDEC JC40.2 Std 17
- ESD protection exceeds 2000V per MIL STD 883 Method 3015 and 200V per Machine Model

DESCRIPTION

The LVT16541A is a high-performance BiCMOS product designed for V_{CC} operation at 3.3V.

This device can be used as two octal buffers or one 16-bit buffer. The device is ideal for driving bus lines.

QUICK REFERENCE DATA

SYMBOL	PARAMETER	CONDITIONS $T_{amb} = 25^{\circ}C; GND = 0V$	TYPICAL	UNIT
t_{PLH} t_{PHL}	Propagation delay nAx to nYx	$C_L = 50pF;$ $V_{CC} = 3.3V$		ns
C_{IN}	Input capacitance nOEx	$V_I = 0V$ or $3.0V$	4	pF
C_{OUT}	Output pin capacitance	Outputs disabled; $V_O = 0V$ or $3.0V$	10	pF
I_{CCZ}	Total supply current	Outputs disabled; $V_{CC} = 3.6V$	100	μA

ORDERING INFORMATION

PACKAGES	TEMPERATURE RANGE	ORDER CODE	DRAWING NUMBER
48-Pin Plastic Shrink Small Outline (SSOP) Type III	$-40^{\circ}C$ to $+85^{\circ}C$	74LVT16541ADL	SOT370-1
48-Pin Plastic Thin Shrink Small Outline (TSSOP) Type II	$-40^{\circ}C$ to $+85^{\circ}C$	74LVT16541ADGG	SOT362-1

LOGIC SYMBOL

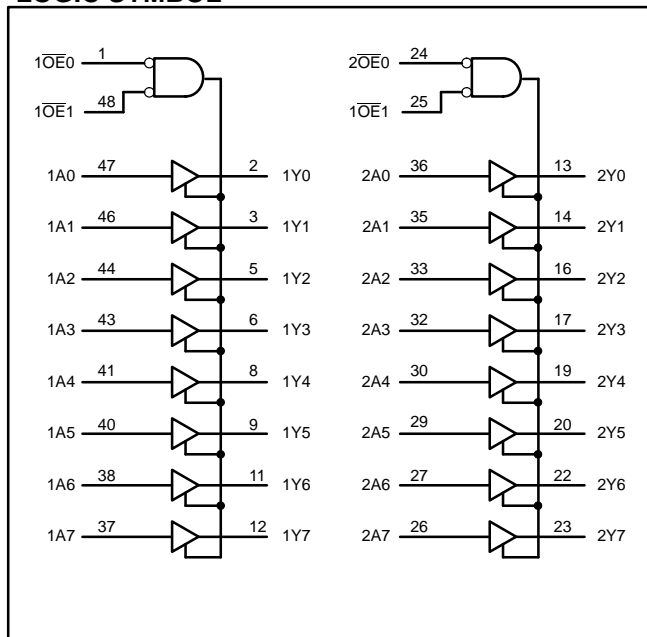

LOGIC SYMBOL (IEEE/IEC)

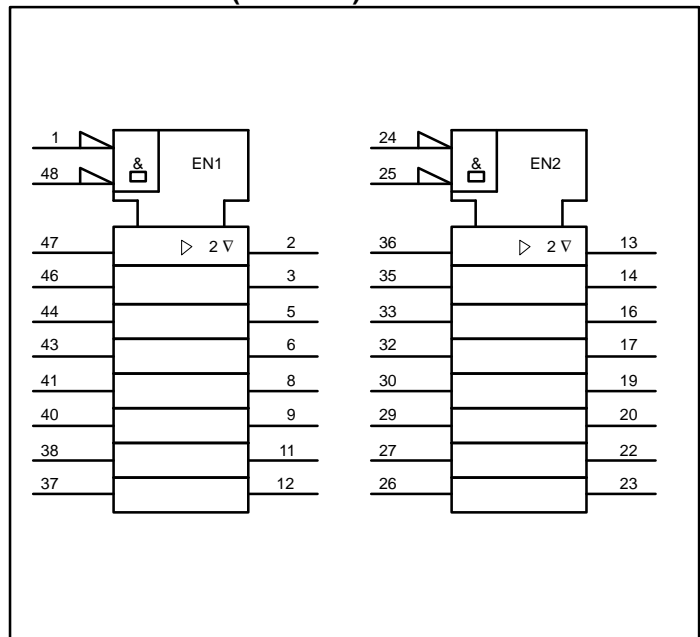

3.3V ABT 16-bit buffer/driver (3-State)

74LVT16541A

PIN CONFIGURATION

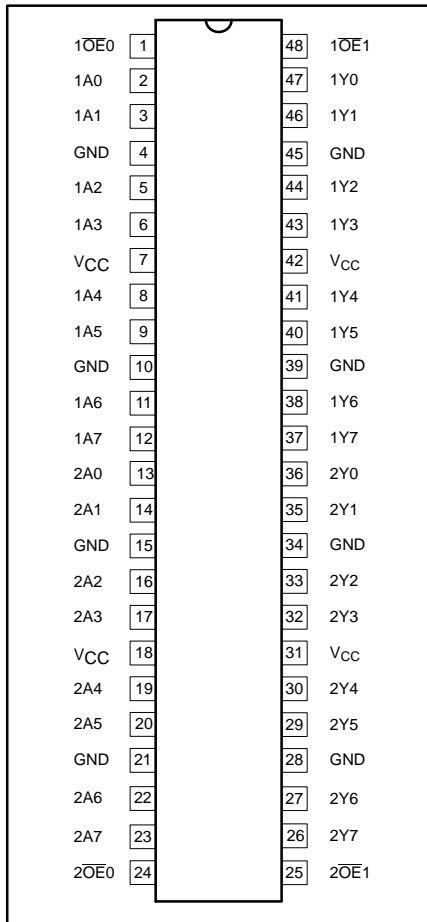

PIN DESCRIPTION

PIN NUMBER	SYMBOL	NAME AND FUNCTION
47, 46, 44, 43, 41, 40, 38, 37, 36, 35, 33, 32, 30, 29, 27, 26	1A0–1A7 2A0–2A7	Data inputs
2, 3, 5, 6, 8, 9, 11, 12, 13, 14, 16, 17, 19, 20, 22, 23	1Y0–1Y7 2Y0–2Y7	Data outputs
1, 48 24, 25	1OE0, 1OE1, 2OE0, 2OE1	Output enables
4, 10, 15, 21, 28, 34, 39, 45	GND	Ground (0V)
7, 18, 31, 42	V _{CC}	Positive supply voltage

FUNCTION TABLE

INPUTS			OUTPUTS
nOE0	nOE1	nAx	nYx
L	L	L	L
L	L	H	H
X	H	X	Z
H	X	X	Z

H = High voltage level
 L = Low voltage level
 X = Don't care
 Z = High Impedance "off" state

3.3V ABT 16-bit buffer/driver (3-State)

74LVT16541A

ABSOLUTE MAXIMUM RATINGS^{1,2}

SYMBOL	PARAMETER	CONDITIONS	RATING	UNIT
V _{CC}	DC supply voltage		-0.5 to +4.6	V
I _{IK}	DC input diode current	V _I < 0	-50	mA
V _I	DC input voltage ³		-0.5 to +7.0	V
I _{OK}	DC output diode current	V _O < 0	-50	mA
V _{OUT}	DC output voltage ³	Output in Off or High state	-0.5 to +7.0	V
I _{OUT}	DC output current	Output in Low state	128	mA
		Output in High state	-64	
T _{stg}	Storage temperature range		-65 to +150	°C

NOTES:

- Stresses beyond those listed may cause permanent damage to the device. These are stress ratings only and functional operation of the device at these or any other conditions beyond those indicated under "recommended operating conditions" is not implied. Exposure to absolute-maximum-rated conditions for extended periods may affect device reliability.
- The performance capability of a high-performance integrated circuit in conjunction with its thermal environment can create junction temperatures which are detrimental to reliability. The maximum junction temperature of this integrated circuit should not exceed 150°C.
- The input and output negative voltage ratings may be exceeded if the input and output clamp current ratings are observed.

RECOMMENDED OPERATING CONDITIONS

SYMBOL	PARAMETER	LIMITS		UNIT
		MIN	MAX	
V _{CC}	DC supply voltage	2.7	3.6	V
V _I	Input voltage	0	5.5	V
V _{IH}	High-level input voltage	2.0		V
V _{IL}	Input voltage		0.8	V
I _{OH}	High-level output current		-32	mA
I _{OL}	Low-level output current		32	mA
	Low-level output current; current duty cycle ≤ 50%; f ≥ 1kHz		64	
Δt/Δv	Input transition rise or fall rate; Outputs enabled		10	ns/V
T _{amb}	Operating free-air temperature range	-40	+85	°C

3.3V ABT 16-bit buffer/driver (3-State)

74LVT16541A

DC ELECTRICAL CHARACTERISTICS

SYMBOL	PARAMETER	TEST CONDITIONS	LIMITS			UNIT
			Temp = -40°C to +85°C			
			MIN	TYP ¹	MAX	
V _{IK}	Input clamp voltage	V _{CC} = 2.7V; I _{IK} = -18mA			-1.2	V
V _{OH}	High-level output voltage	V _{CC} = 2.7 to 3.6V; I _{OH} = -100μA	V _{CC} -0.2			V
		V _{CC} = 2.7V; I _{OH} = -8mA	2.4			
		V _{CC} = 3.0V; I _{OH} = -32mA	2.0			
V _{OL}	Low-level output voltage	V _{CC} = 2.7V; I _{OL} = 100μA				V
		V _{CC} = 2.7V; I _{OL} = 24mA				
		V _{CC} = 3.0V; I _{OL} = 16mA				
		V _{CC} = 3.0V; I _{OL} = 32mA				
		V _{CC} = 3.0V; I _{OL} = 64mA				
I _I	Input leakage current	V _{CC} = 3.6V; V _I = V _{CC} or GND	Control pins		±1	μA
		V _{CC} = 0 or 3.6V; V _I = 5.5V			10	
		V _{CC} = 3.6V; V _I = V _{CC}	Data pins ⁴		1	
		V _{CC} = 3.6V; V _I = 0			-5	
I _{OFF}	Output off current	V _{CC} = 0V; V _I or V _O = 0 to 4.5V			±100	μA
I _{HOLD}	Bus Hold current A inputs	V _{CC} = 3V; V _I = 0.8V	75		μA	
		V _{CC} = 3V; V _I = 2.0V	-75		μA	
I _{EX}	Current into an output in the High state when V _O > V _{CC}	V _O = 5.5V; V _{CC} = 3.0V			125	μA
I _{PU/PD}	Power up/down 3-State output current ³	V _{CC} ≤ 1.2V; V _O = 0.5V to V _{CC} ; V _I = GND or V _{CC} ; OE/OE = Don't care			±100	μA
I _{OZH}	3-State output High current	V _{CC} = 3.6V; V _O = 3.0V; V _I = V _{IL} or V _{IH}			5	μA
I _{OZL}	3-State output Low current	V _{CC} = 3.6V; V _O = 0.5V; V _I = V _{IL} or V _{IH}			-5	μA
I _{CCH}	Quiescent supply current	V _{CC} = 3.6V; Outputs High, V _I = GND or V _{CC} , I _O = 0	0.13	0.12	mA	
I _{CCL}		V _{CC} = 3.6V; Outputs Low, V _I = GND or V _{CC} , I _O = 0	3.5	5		
I _{CCZ}		V _{CC} = 3.6V; Outputs Disabled; V _I = GND or V _{CC} , I _O = 0	0.13	0.12		
ΔI _{CC}	Additional supply current per input pin ²	V _{CC} = 3V to 3.6V; One input at V _{CC} -0.6V, Other inputs at V _{CC} or GND			0.2	mA

NOTES:

- All typical values are at V_{CC} = 3.3V and T_{amb} = 25°C.
- This is the increase in supply current for each input at the specified voltage level other than V_{CC} or GND
- This parameter is valid for any V_{CC} between 0V and 1.2V with a transition time of up to 10msec. From V_{CC} = 1.2V to V_{CC} = 3.3V ± 0.3V a transition time of 100μsec is permitted. This parameter is valid for T_{amb} = 25°C only.
- Unused pins at V_{CC} or GND.

AC CHARACTERISTICS

GND = 0V; t_R = t_F = 2.5ns; C_L = 50pF; R_L = 500Ω; T_{amb} = -40°C to +85°C.

SYMBOL	PARAMETER	WAVEFORM	LIMITS				UNIT
			V _{CC} = 3.3V ± 0.3V			V _{CC} = 2.7V	
			MIN	TYP ¹	MAX	MAX	
t _{PLH} t _{PHL}	Propagation delay nAx to nYx	1					ns
t _{PZH} t _{PZL}	Output enable time to High and Low level	2					ns
t _{PHZ} t _{PLZ}	Output disable time from High and Low Level	2					ns

NOTE:

- All typical values are at V_{CC} = 3.3V and T_{amb} = 25°C.

3.3V ABT 16-bit buffer/driver (3-State)

74LVT16541A

AC WAVEFORMS

$V_M = 1.5V$, $V_{IN} = GND$ to $2.7V$

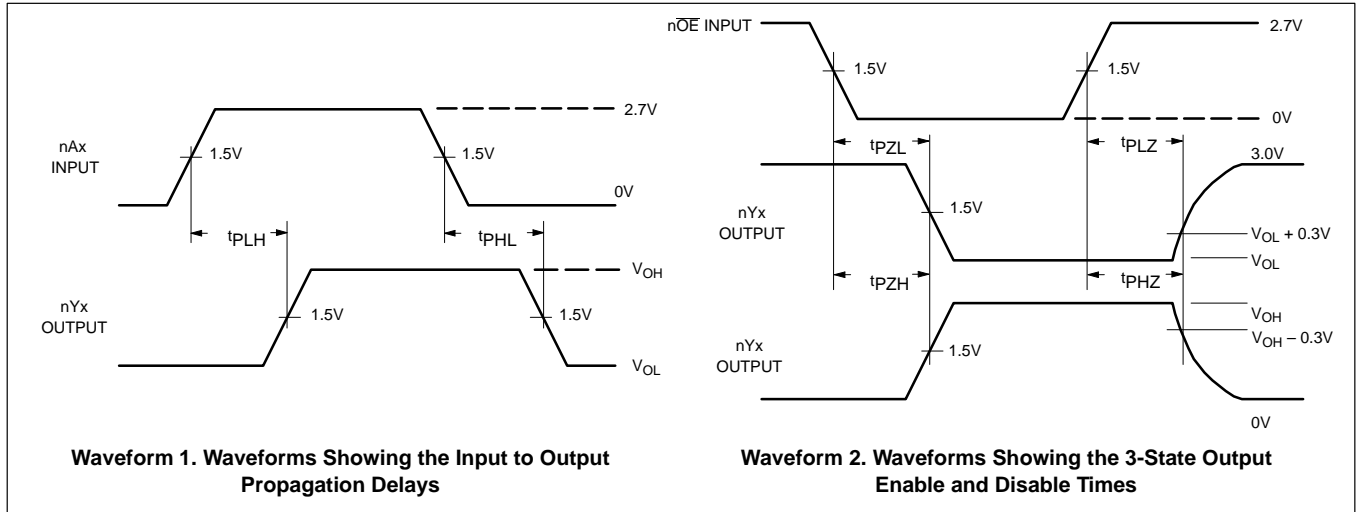

TEST CIRCUIT AND WAVEFORMS

