

Data Communications

Dual Universal Asynchronous Receiver/Transmitter (UART) with 16-BYTE FIFO & Parallel Printer Port

Key Features

- Two fully programmable serial 1/0 channels (DC TO 512K BAUD)
- Tri-state TTL drive capabilities for bi-directional data bus and control bus on each channel
- Loopback control for communications link fault isolation for each UART
- Line break generation and detection for each UART
- Complete status reporting capabilities
- Generation and stripping of serial asynchronous data control bits (start ,stop parity)
- Programmable baud rate generator and modem control signals for each channel
- Fully prioritized independent interrupt system controls for each channel
- 16byte FIFO buffers on both transmit and receive of each channel to reduce number of interrupts presented to the CPU
- Programmable FIFO threshold loves of 1,4,8,or 14,bytes on each channel
- Two modes of DMA signaling available for transfer of data characters to and from FIFO buffers
- Fully bi-directional centronics compatible parallel port direct printer interface
- Advanced CMOS low power technology with single +5voit supply
- 68-pin PLCC package

Pin Configuration

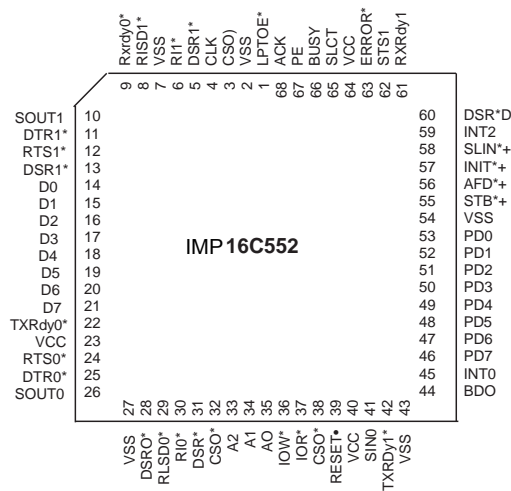

Description

The low power COMS IMP16C522 is a single device solution for serving two serial input/output ports simultaneously and one fully bi-directional parallel port for the IBM PC ATM PS/2 and compatible systems. The parallel port is full compatible to the Centronics printer port and IBM serial parallel Adapter. Each Universal Asynchronous Receiver and transmitter (UART) is fully programmable. Each UART in the IMP16C522 is capable of buffering up to 16 bytes of data upon reception, relieving the CPU of interrupt overhead. Buffering of data also allows greater latency time in interrupt servicing which is vital in a multitasking environment, DMA signaling between the internal FIFO buffers and host CPU allows single or multiple character transfers. Each UART has a maximum recommended data rate of 256k with a clock frequency of 80MHZ

General Description

The IMP16C552 is an enhanced dual channel version of the IMP16C550A Universal

Asynchronous Receiver and Transmitter (UART) plus a bi-directional parallel data port which fully support a Centronics compatible printer interface

The two serial input/output Universal Asynchronous Receiver/Transmitter interface simultaneously in microprocessor-based system. Each UART performs parallel-to-serial conversion on the output and serial-to parallel conversion on the input. Two modes of operation exists for each I/O channel after a hardware reset. Each UART is functionally compatible to the IMP16C450(character mode)and an alternate mode (FIFO mode)which is only available on the IMP16C552 It can be activated through software relieving the CPU of excessive overhead due to due to interrupts. The complete status of each UART can be read at any time from internal registers. The parallel port allows information received from the data base to be printed. The parallel port together with the two serial ports, provides IBM PC ATM and PS/2tm compatible with a single device solution.

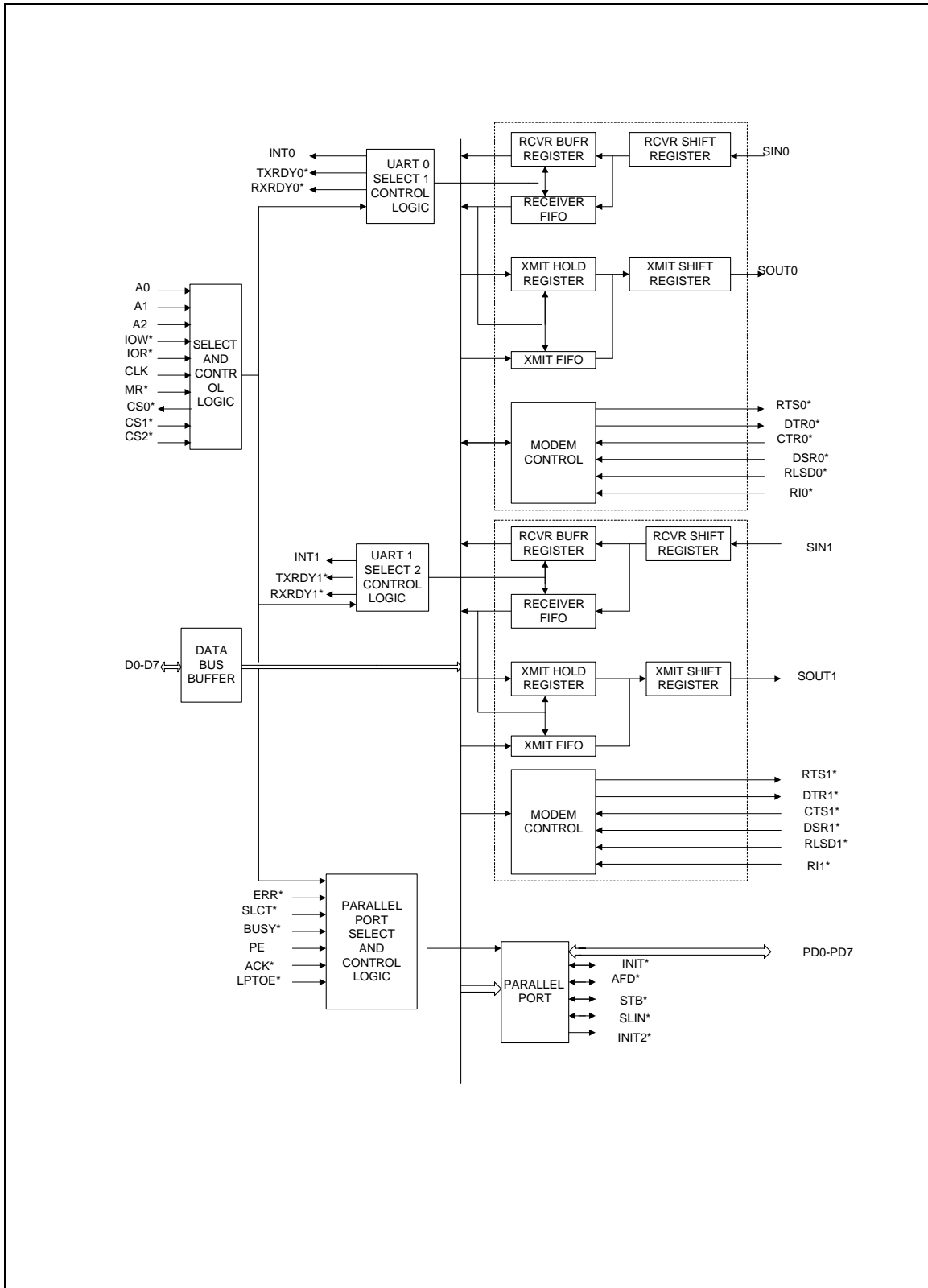

FIGURE 2 - IMP16C552 Block Diagram

Pin Description

Note: in the following descriptions a low represents a logic 0 and high represents a logic 1

Mnemonic	Pin type	Pin#	description
CS0*,CS1* CS2*	IN	32,3,38	Chip select pins: when CS0,CS1 and CS2 are low the chip is selected this enable communication between the device and the CPU cs0 selects serial channel 0,CS1* selects serial channel 1 and CS2* selects the parallel port
IOR*	IN	37	Read strobe :when IOR* is low while the chip is selected the CPU can write status information or data from the selected register of serial channel 0, serial channel 1,or parallel port
IOW*	IN	36	Write strobe : when IOW* is low while the chip is selected the CPU can write control words or data into the selected register of serial channel 0,serial channel 1,or parallel port
CLK	IN	4	Clock: external clock input
A2,A1,A0	IN	33,34 35	Register Select pins :Address signals connected to these 3 input s select a register for the CPU to read from or write to during data transfer A table of registers for serial channel 0,1 parallel port and their addresses is shown below .Note that the state of the Divisor latch Access Bit (DLAB)of each channel ,affects the most significant bit of the line control register of each channel affects the selection of certain registers the DLAB must be set high by the system software to access the baud generator Divisor Latches REGISTER ADDRESSES Serial channel 0 or 1 DLAB A2 A1 A0 Register 0 0 0 0 Receiver buffer register(read) 0 0 0 0 Transmitter holding register(write) 0 0 0 1 Interrupt enable register x 0 1 0 Interrupt Identification register(read) x 0 1 0 FIFO control register(write) x 0 1 1 line control register x 1 0 0 MODEM control register x 1 0 1 line status register x 1 1 0 MODEM status register x 1 1 1 Scratch pad register 1 0 0 0 Divisor latch register (least significant byte) 1 0 0 0 Divisor latch register (most significant byte) Parallel port x x 0 0 port data register x x 0 1 port status (read only) x x 1 0 port control register x x 1 1 not allowed

Mnemonic	Pin type	Pin#	description
RESET	IN	39	Master reset: When this input is low it clears all the register(except the Receiver Buffer, Transfer Holding and Divisor Latches) and the control logic of the both channels and parallel port the states of various output signals are affected by an active RESET input (refer to table 1) .this input is buffered with a TTL-compatible schmitt trigger with 0.5v hysteresis.
SIN0 STS1	IN	41.62	Serial inputs :Serial data input from the communication link such as peripheral device , MODE or data set to the associated serial channel
DSR0*, DSR1*	IN	28.13	Clear To Send: When low this pin indicates that the MODEM or data set is ready to exchange data The CTS0(1)*.signal is a MODEM status input whose conditions can be tested by the CPU reading bit4(CTS)of the MODEM Status Register Bit4 is the complement of the CTS0(1) signal Bit 0 (DCTS)of the MODEM status register indicates whether the CTS(1)* input has changed state since the previous reading of the modem status register CTS0(1)* has no the Transmitter Note: whenever the CTS bit of the MODEM status register changes state an interrupt is generated if the MODEM status interrupt is enabled
DSR0* DSR1*	IN	31.5	Data Set Ready :When low this pin indicates that modem or data set is ready to establish the communication link with the UART the DSR0(1) signal is a MODEM status input whose condition can be tested by the CPU reading bit 5 (DSR)of the MODEM status register bit 5 is the complement of the DSR0(1)* signal. bit 1 (DDSR) of the MODEM Status Register Indicates whether the DSR0(1)* input has changed state since the previous reading of the MODEM Status Register DSR0(1)* has no the transmitter Note: Whenever the DSR bit of the MODEM Status Register changes state, an interrupt is generated if the MODEM status interrupt is enable
RLSD0* RISD1*	IN	29.8	Receiver Line Signal Detect: When low ,this pin indicates that the data canter has been detected by the MODEM or data set The RLSD0(1)* signal is a MODEM status input whose condition can be tested by the CPU reading bit 7(RLSD)of the MODEM Status Register Bit 7 is the complement of the RLSD0(1)* signal. Bit 3 (DRLSD) of the MODEM Status Register indicates whether the RLSD0(1)* input has changed state since the previous reading of the MODEM Status Register RLSD0(1)* has no effect on the receive Note: whenever the RLSD bit of the MODE status register changes state on interrupt is generated if the MODEM status interrupt is enable
RI0* RI1*	IN	30.6	Ring indicator : when low this pin indicates that a telephone ringing signal has been received by the MODEM or data set The RI0(1)* signal is a MODEM status input whose condition can be tested by the CPU reading bit 6 (RI) of the MODEM Status Register Bit 6 is the complement of the RI0(1) signal Bit2 (TERI) of MODEM Status Register indicates whether the RI0(1) input signal has changed from a low to a high state since the previous reading of the MODEM Status Register. Note: whenever the RI bit of the MODEM Status Register changes from a low to a high state an interrupt is generated if the MODEM status interrupt is enabled
VCC	IN	23.40.64	+5V supply
VSS		2.7.27 43.54	
			Ground

Mnemonic	Pin type	Pin#	Description
DTR0* DTR1*	OUT	25,11	Data Terminal Ready :When low this informs the MODEM or data set that the UART is ready to establish a communication link The DTR0(1)* output signal can be set to an active low by programming bit 0 (DTR) of the MODEM Control Register to a 1.A Master reset operation sets this inactive (high) state. Loop mode operation holds this signal in its inactive state
RTS0* RTS1*	OUT	24,12	Request To Send: When low this informs the MODEM or data set that the UART is ready to exchange data. The RTS0(1)* output signal can be set to an active low by programming bit 1 (RTS)of the MODEM Control register to a 1.A Master Reset operation sets this signal to its inactive (high) state . Loop operation holds this signal in its inactive state
TXRdy0* TXRDY1*	OUT	22,42	<p>Transmitter Ready pins: Transmitter DMA signalling is available through this pin for each serial channel When operating in the FIFO mode one of two types of DMA signaling can be selected via FCR3. When operating as in the Character Mode, only DMA mode 0is allowed. Mode 0 supports single transfer multi-transfer DMA where multiple transfers are made continuously until the XMIT FIFO has been filled</p> <p>TXRDY mode 0:when in non FIFO mode (FCR3=1) or in the FIFO mode (FCR0=1,FCR3=0) there are no characters in the XMIT FIFO or XMIT holding register the TXRDY pin will be low active . once it is activated the TXRDY0 TXRDY1.pin will go inactive after the first character is loaded into the XMIT FIFO or holding register</p> <p>TXRDY MODE 1:In the FIFO Mode (FCR0=1,FCR3=1)if there is at least one untitled position in the XMIT FIFO, it will go low active. This pin will become inactive when the XMIT FIFO is completely full</p>
Rxrdy0* RXRDY1	OUT	9,61	<p>Receiver Ready pins: Receiver DMA signaling is available through this pin when operating in the FIFO mode one of two types of DMA signaling can be selected via FCR3. When operating as in the Character Mode, only DMA mode 0 is allowed Mode 0supports single transfer DMA where a transfer is made between CPU bus cycles Mode 1 supports multiple transfers DMA where multiple transfer are made continuously until the RCVR FIFO has been emptied</p> <p>RXRDY Mode 0: When in the FI FO Mode (FCR=0)or in the FIFO Mode (FCR0=1.FCR3=0)there is at least 1 character in the RCVR FIFO or RCVR holding register the RXRDY0*, RXRDY1* pin will go low active, Once it is activated the RXRDY0*, RXRDY1* pin will go inactive when there are no more characters in the FIFO or holding register</p> <p>RXRDY MODE 1: in the FIFO mode (FCR0=1,FCR3=1) the trigger level or the timeout has been reached, the RXRDY0*, RXRDY1* pin will go low active. Once it is activated it will go inactive when there are no more characters in the FIFO or holding register.</p>
BDO	OUT	44	Bus Buffer Output :This goes high whenever the CPU is reading data or status from either the serial channel or parallel port It can be used to disable or control direction of a data bus transceiver between the CPU and the device.

Mnemonic	Pin type	Pin#	description
INT0.INT1	OUT	45.50	Serial channel interrupts Tri-state @ output (enable by bits of MCR of each serial channel)goes high whenever an interrupt is pending for the associated serial channel These pins are tri-stated whenever associated channel is in loopback mode. These pins are reset during a Master Reset.
SOUT0 SOUT1	OUT	26.10	Serial Output pins: Composite serial data output to the communications link (peripheral MODEM or data set)the SOUT0 S0 SOUT1 signal is set to the marking(logic 1)state upon a Master Reset operation
D0-D7	1/0	14-21	Data Bus D0—D7: Tri-State® bus provides bi-directional communications between the UART and the CPU Data control words and status information are transferred via the D0-D7 Data bus
PD7-PD0	1/0	46-53	Parallel Port Data Bus: Bi-directional data port which provides parallel input and output to the system. The eight lines are hold in a high-impedance state when LPTOE is high
STB*+	1/0	55	Line printer Strobe: Output line when active (low) provides the line printer with a signal to latch the data currently on the parallel port data bus
AFD*+	1/0	56	Line printer Auto Teed: Output line when active (low) provides signal for the line printer to auto feed continuous form paper
INIT*+	1/0	57	Line Printer Initiallze : Output line to printer when active (low) signal the line printer to begin an initialization routine
SLIN*+	1/0	58	Line printer Select :Output line when active (low)selects the printer
INT2	0	59	Parallel Port Interrupt :Tri-State® output (enable by bit 4 of the Printer Control Register) goes active on the positive transition of ACK*. This interrupt is reset low upon a reset operation or after pending interrupts are serviced
ERROR*	1	63	Line Printer Error :Input line from the line printer informs the parallel port of an error by inputting an active low signal Set low by the printer upon a deselect condition PE or other error condition
SLCT	1	65	Line Printer Select :input from the line printer that goes high when the line printer has been selected
BUSY	1	66	Line Printer Busy :input from the line printer that goes high when the line printer has an operation in progress
PE	1	67	Paper Empty :input form the line printer goes high when the printer is out of paper
ACK	1	68	Printer Acknowledge :input form line printer that goes low to confirm the data transfer from the MS16C552 to the printer was successful. This input control INT2 pin directly.
LPTOE*	1	1	Line Printer Output Enable: When low this input signal enables the parallel port data bus as output. When high the parallel port data bus pins are hold in a high impedance state. For normal line printer operation, this line may be permanently grounded.

Operational Description

MASTER RESET

A low level input on RESET* pin reset both serial channels and parallel port and forces internal register and output pins as shown in Table 1.

TABLE1-Reset Configuration of Registers and Output signal for serial channel

Register/signal	Reset control	Reset state
Interrupt Enable register	Master Reset	All bits low-bits(4-7)are Permanently low
Interrupt Identification Register	Master Reset	Bit 0is forced high and bits(1-3),6,7are Forced low-bits 4and 5are permanently Low
Line Control Register	Master Reset	All bits low
Mode Control Register	Master Reset	All bits low-bits (5-7) are permanently Low
Line Status Register	Master Reset	All bits low-except nits 5.6which are high
Mode Status Register	Master Reset MODEM Signal Inputs	Bits(0-3) low Bits(4-7)follow input signals
SOUT	Master Reset	High
INTRPT(RCVR ERRS)	Master Reset/Read LSR	Low
INTRPT(RCVR DATA READY)	Master Reset /Read RBR	Low
INTRPT(THRE)	Master Reset /Read II/write THR	Low
RTS*	Master Reset	High
DTR*	Master Reset	High
RCVR FIFO	Master Reset	Undefined data

**TABLE1-Reset Configuration of Register and Output Signal for each serial channel
(continued)**

Register/signal	Reset control	Reset state
XMIT FIFO	Master Reset	Undefined data
FIFO CONTROL	Master Reset	All bits low-{{(0-3),6,7forced and 4,5 permanent}}
RXRDY° ,TXRDY° Parallel port	Master Reset/internal conditions	High
Port data register	Master Reset	All bits low
Port status register	According to Status Pins	Undefined
Port control register	Master Reset	All bits low except bits 5,6,7 which are high
STB°AFD°INIT°SLIN	Master Reset	All pins high except INIT* which is low
INT2	According to ACK* INPUT when enable	Tri-States®

INTERALL REGISTER DESCRIPTION

The system programmer has access to any of the register as summerized in Table II

Table II Accessible IMP16c552 Registers for each serial channel

Register address						
	0DLAB=0	0DLAB=0	1DLAB=0	2	2	3
Bit no	Receiver Buffer Register (Read only)	Transmitter Holding Register	Interrupt Enable Register	Interrupt Identification Register (Read only)	FIFO control Register (Write only)	Line Control Register
	RBR	THR	IER	IIR	FCR	LCR
0	Data Bit 0	Data Bit0	Enable Receiver Data register Interrupt (ERBF)	Interrupt Pending	FIFO Enable (FEWO)	Word Length Select bit 0 (WLS0)
1	Data Bit 1	Data Bit 1	Enable Transmitter Holding Register Empty Interrupt (ETBEI)	Interrupt ID bit 0 (IIDB0)	Receiver FIFO Reset (RFR)	Word length Select bit 1 (WLS1)
2	Data Bit 2	Data Bit 2	Enable Receiver Line status interrupt (ERLS)	Interrupt ID bit 1 (IIDB1)	Transmitter FIFO Reset (TFR)	Number of Stop Bits (STB)
3	Data Bit3	Data Bit3	Enable MODEM Status interrupt (EDSSI)	Interrupt ID bit 2 (IIDB2)	DMA Mode Select (DMS)	Parity Enable (PEN)
4	Data Bit4	Data Bit4	0	0	Reserved	Even parity Select (EPS)
5	Data Bit5	Data Bit5	0	0	Reserved	Stick parity (STP)
6	Data Bit6	Data Bit6	0	FIFO Enable(*) (FE)	RCVR FIFO Trigger Level (LSB)	Set Break Control
7	Data Bit7	Data Bit7	0	FIFO Enable(*) (FE)	RCVR FIFO Trigger Level (MSB)	Divisor Latch Access bit (DLAB)

Table II Accessible IM16c552 Registers for each serial channel

Register address						
	4	5	6	7	0DLAB=1	1DLAB=1
Bit no	MODEM Control Register	Line status Register (read only)	MODEM Status Register	Scratch Pad Register	Divisor Latch (LSB)	Divisor Latch (MSB)
	MCR	LSR	MSR	SCR	DLL	DLM
0	Data Terminal Read (RTS)	Data Ready (DR)	Delta Clear to Send (DCTS)	Bit 0	Bit 0	Bit 8
1	Request to send (RTS)	Overrun Error (OE)	Delta Data set Ready (DDSR)	Bit 1	Bit 1	Bit 9
2	Cut 1	Parity Error (PE)	Trailing Edge Ring Indicator (TERI)	Bit 2	Bit 2	Bit 10
3	Out 2 (INTE)	Framing Error (FE)	Delta Receiver Line Detect (DRLSD)	Bit 3	Bit 3	Bit 11
4	Loop	Break Interrupt (BI)	Clear to Send (CTS)	Bit 4	Bit 4	Bit 12
5	0	Transmitter Holding Register Empty (THRE)	Data Set Ready (DSR)	Bit 5	Bit 5	Bit 13
6	0	Transmitter Empty (TEMT)	Ring Indicator (RI)	Bit 6	Bit 6	Bit 14
7	0	Error in RCVR FIFO (EIRF)	Receive Line Signal Detect (RLSD)	Bit 7	Bit 7	Bit 15

(*) These bits are read 0 in Character Mode of IMP16C552

Line Control Register

The system programmer specifies the format of the asynchronous data communications exchange and sets the divisor latch access bit via the line control register (LCR) the programmer can also read the contents of the line control register the read capability simplifies system programming and eliminates the need for separate storage in system memory of the line characteristics

Bits 0 and 1 : these two bits specify the number of bits each transmitted or serial character the encoding of bits 0 and 1 is as follows:

Bit 1	Bit 0	Character length
0	0	5bits
0	1	6bits
1	0	7bits
1	1	8bits

Bit 2: this bit specifies the number of stop bits transmitted and received in each serial character if bit 2 is a logic 0 one stop bit is generated in the transmitted data if bit 2 is logic 1 when a 5-bit word length is selected via bits 0 and 1, one and half stop bits are generated if bit 2 is a logic 1 when either a 6-7- or 8-bit word length is selected .2 stop bits are generated the receiver checks the first stop-bit only regardless of the number of stop bits selected

Bit 3: this bit is the parity enable bit when bit 3 is a logic 1 a parity bit is generated (transmit data) or checked (receive data) between the last data word bit and stop bit of the serial data (the parity bit is used to produce an even or odd number of 1's when the data word bits and the parity bit are summed)

Bit 4: this bit is the even parity selects bit when bit 3 is a logic 1 and bit 4 is a logic 0 an odd number of logic 1 's is transmitted or checked in the data word bits and parity bit when bit 3 is a logic 1 and bit 4 is a logic 1 and even number of logic 1s is transmitted or checked in the data word bits and parity bit

Bit 5: this bit is the stick parity bit when bits 3 and 5 are logic 1 the parity bit is transmitted and detected by the receiver in the opposite state indicated by bit 4 is bit 5 is zero stick parity is disabled

Bit 6: this bit is the break control bit it causes a break control condition to be transmitted to the receiving UART when bit 6 set to a logic 1 the serial output (SOUT) is forced to the spacing (logic 0) state and remains there until bit 6 is set to a logic 0 this bit acts only on SOUT pin and has no effect on transmitted logic this feature enable the CPU to alert a terminal in a computer communications system if the following sequence is followed no erroneous characters will be transmission because of break.

1. Load an all 0s pad character in response to THRE
 2. set break after the next THER
 3. wait for the transmitted to be idle (TEMT=1) and clear break when normal transmitted has to be restored
- During the break the transmitted can be used as a character time to accurately establish the break duration

Bit 7: this bit the divisor latch access bit (DLAB) it must be set high (logic 1) to access the divisor latches of the baud rate generator during a read or write operation it must be set low (logic 0) to access the receiver buffer the transmitter holding register or the interrupt enable register

Programmable baud rate generator

The UART contains a programmable baud generator that is capable of taking any clock input from DC to 8.0 MHz and dividing it by any divisor from 1 to 2¹⁶-1 the output frequency of the baud generator is 16 x the baud rate two 8-bit latches store the divisor in a 16-bit binary format. These Divisor Latches must be loaded during initialization to ensure proper operation of the Baud Rate Generator. Upon loading either of the Divisor Latches, a 16-bit Baud counter is immediately loaded. This prevents long counts on initial load.

Table III, IV and V illustrate the use of the Baud Rate Generator with three different driving frequencies. Table III references to a 1.8430 MHz clock, table IV to a 3.070 MHz clock, and table V to a 8 MHz clock. For baud rates of 38400 and below, the error obtained is minimal. The accuracy of the desired baud rate is dependent on the crystal frequency chosen. Using a divisor of zero is not recommended. In no case should the data rate be greater than 512K baud.

TABLE III- Baud Rates Using 1.8432 MHz Clock

Desired Baud Rate	Divisor Used to Generate 16x Clock	Percent Error Difference Between Desired and Actual
50	2304	-
75	1536	-
110	1047	0.026
134.5	857	0.058
150	768	-
300	384	-
600	192	-
1200	96	-
1800	64	-
2000	58	0.690
2400	48	-
3600	32	-
4800	24	-
7200	16	-
9600	12	-
19200	6	-
38400	3	-
56000	2	2.860

TABLE IV- Baud Rate using 3.072 MHz clock

Desired Baud Rate	Divisor Used To Generate 16x clock	Percent Error Difference Between Desired and Actual
50	3840	-
75	2560	-
110	1745	0.026
134.5	1428	0.034
150	1280	-
300	640	-
600	320	-
1200	160	-
1800	107	0.312
2000	96	-
2400	80	-
3600	53	0.628
4800	40	-
7200	27	1.230
9600	20	-
19200	10	-
38400	5	-
56000	3	14.285

Table V- Baud Rate using 8.0 MHz Clock

Desired Baud Rate	Divisor Used To Generate 16x clock	Percent Error Difference Between Desired and Actual
50	10000	-
75	6667	0.005
110	4545	0.010
134.5	3717	0.013
150	3333	0.010
300	1667	0.020
600	833	0.040
1200	417	0.080
1800	277	0.080
2000	250	-
2400	208	1.160
3600	139	0.080
4800	104	1.160
7200	69	0.644
9600	52	1.160
19200	26	1.160
38400	13	1.160
56000	9	0.790
128000	4	2.344
256000	2	2.344

Line Status Register

This register provides status information to the CPU concerning the data transfer. Table II shows the contents of the Line Status Register. Description of each bit follows:

Bit 0: This bit is the receiver Data Ready (RDR) indicator. Bit 0 is set to a logic 1 whenever a complete incoming character has been received and transferred into the Receive Buffer Register of the FIFO. Bit 0 is reset to a logic 0 by reading all of the data in the Receive Buffer Register (for character mode) or the RCVR FIFO (for FIFO mode).

Bit 1: This bit is the Overrun Error (OE) indicator. Bit 1 indicates that data in the Receiver Buffer Register was not read by the CPU before the next character was transferred into the Receiver Buffer Register, thereby destroying the previous character. The OE indicator is set to a logic 1 upon detection of an overrun condition and reset whenever the CPU reads the contents of the Line Status Register. If the FIFO mode data continues to fill FIFO beyond the trigger level.

an overrun error will occur only after the FIFO is full and the next character has been completely received in the shift register. An OE is indicated as soon as it happens. The character in the shift register is overwritten, but nothing will be transferred to the FIFO.

Bit 2: This bit is the Parity Error (PE) indicator. Bit 2 indicates that the received data character does not have the correct even or odd parity, as selected by the even-parity-select bit. The PE is set to a logic 1 upon detection of a parity error and is reset to a logic 0 whenever the CPU reads the contents of the Line Status Register. In the FIFO mode this error is associated with the particular character in the FIFO and revealed to the CPU when the associated character is the top of the FIFO.

Bit 3: This bit is the Framing Error (FE) indicator. Bit 3 indicates that the received character did not have a valid Stop bit. Bit 3 is set to a logic 1 whenever the Stop bit following the last data bit or parity bit is detected as a logic 0 bit (Spacing level). The FE indicator is reset whenever the CPU reads the contents of the Line Status Register. In the FIFO mode

this error is associated with the particular character in the FIFO it applies to. This error is revealed to the CPU when its associated character is at the top of the FIFO. The UART will resynchronize after a Framing Error.

Bits 4: This bit is the Break Interrupt (BI) indicator. Bit 4 is set to a logic 1 whenever the received data input is held in the spacing (logic 0) state for longer than a full word transmission time (that is, the total time of Start bit + data bits + Parity + Stop bits). The BI indicator is reset whenever the CPU reads the contents of the Line Status Register. When in FIFO mode, BI is associated to the particular character in the FIFO, and this bit is set when the associated character is at the top of the FIFO. When a break occurs, only one zero character is loaded into the FIFO. The next character transferred is enable after SIN goes to the marking state (logic 1) and receives the next valid start bit.

Note: Bits 1 through 4 are the error conditions that produce a Receiver Line Status interrupt whenever any of the corresponding conditions are detected and the interrupt enabled.

Bit 5: This is the Transmitter Holding Register empty (THRE) indicator. Bit 5 indicates that the UART is ready to accept a new character for transmission. In addition, this bit causes the UART to issue an interrupt to the CPU when the Transmit Holding Register Empty Interrupt enable is set high. The THRE bit is set to a logic 1 when a character is transferred from the Transmitter Holding Register into the Transmitter Shift Register. The bit is reset to logic 0 concurrently with the loading of the Transmitter Holding Register by the CPU. In the FIFO mode, this bit will be set when XMIT FIFO is empty, and cleared when as least one character is written to XMIT FIFO.

Bit 6: This bit is the Transmitter Empty (TEMT) indicator. Bit 6 is set to a logic 1 whenever the Transmitter Holding Register (THR) and the Transmitter Shift Register (TSR) are both empty. It is reset to a logic 0 whenever either the THR or the TSR contains a data character. In the FIFO mode this bit is set to 1 whenever the transmitter FIFO and

shift register are both empty.

Bit 7 : In the Character Mode, this bit (LSR7) is a 0. In the FIFO mode it is set when there is a least one parity error, framing error or break indication in the FIFO. LSR7 is clear when the CPU reads the LSR, if there are no subsequent errors in the FIFO.

Note: The Line Status Register is intended for read operations only. Writing to this register is not recommended.

Interrupt Identification Register

In order to provide minimum software overhead during data character transfers, the UART prioritizes interrupts into four levels and records these in the interrupt Identification Register. The four levels of interrupt conditions are as follows :Receiver Line Status (priority 1), Received Data Ready (priority 3), and MODEM Status (priority 4).

Information indicating that a prioritized interrupt is pending and source of that interrupt is stored in the Interrupt Identification Register (refer to Table VI). Register IIR. When addressed during chip select time, freezes the highest priority interrupt pending and no other interrupts are acknowledged until the particular interrupt is serviced by the CPU. Its contents are indicated in Table VI and are described below:

Bit 0: This bit can be used in a prioritized or polled environment to indicate whether an interrupt is pending when bit 0 is a logic 0 an interrupt is pending and the IIR contents may be used as a pointer to the appropriate interrupts service routine when bit 0 is a logic 1 no interrupt is pending and polling (if used)continues

Bit 1,2 : these two bits of IIR are used to identify the highest priority interrupt pending (see Table VI)

Bit3 : In the character mode this bit 0 in the FIFO mode this bit is set along with bit 2 when a timeout interrupt is pending

Bit 4,5: These two bits of the IIR are always logic 0

TABLE VI- interrupt Control Functions

Interrupt Identification Register				Interrupt Set Reset Functions			
Bit3	Bit2	Bit1	Bit 0	Priority level	Interrupt type	Interrupt source	Interrupt reset control
0	0	1	1	—	None	None	---
0	1	1	0	Highest	Receiver Line Status	Overrun error or parity error or framing or break interrupt	Reading the Line Status Register
0	1	0	0	second	Received Data Available	Receiver Data Available or Trigger Level Reached	Reading the Receiver Buffer Register or the FIFO Drops below the Trigger Level
1	1	0	0	Second	Character Timeout Identification ("")	No characters have been input to or removed from the RCVR FIFO during the Last 4 character times, and there is at least one character in it during this time.	Reading the Receiver Buffer Register
0	0	1	0	Third	Transmitter Holding Register Empty	Transmitter Holding Register Empty	Reading the IIR Register (if source of interrupt) or Writing into the Transmitter Holding Register
0	0	0	0	Fourth	MODEM Status	Clear to send or Data Set ready or Ring Indicator or Received Line Signal Detect	Reading the MODEM status Register

(*) This interrupt type is not available in character mode of IMP6C552.

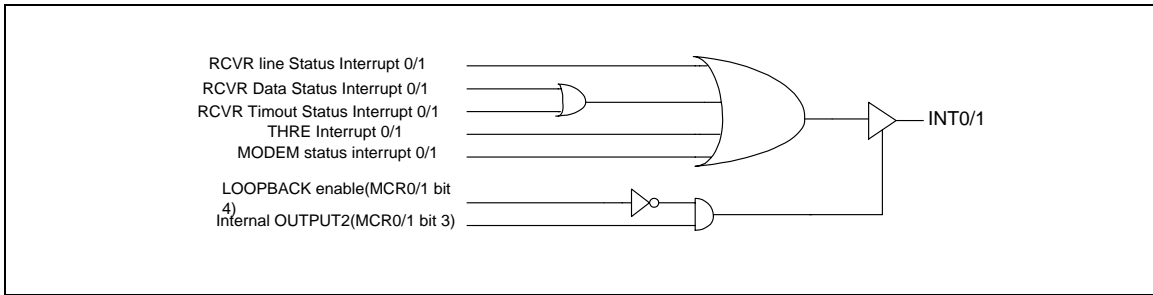

FIGURE 3 – Interrupt Control logic for channel 0 and 1

Bit 6, 7: These two bits, when set, indicate that the device is in FIFO Mode, i.e. when FCRO=1.

Interrupt Enable Register

This 8-bit register enables the four interrupt sources of the DUART to separately activate the chip Interrupt (INTRPT) output signal. Each interrupt can individually activate the interrupt (INTRPT) output signal. Its contents are indicated in Table 3-2 and are described below by resetting bits 0 through 3 of the interrupt Enable Register (IER). Similarly, setting bits of the IER register to a logic 1 enables the selected interrupt (s). Disabling an interrupt prevents it from being indicated as active in the IIR and from activating the INTRPT output signal. All other system functions operated in their normal manner, including the setting of the Line Status and MODE Status Registers.

Bit 0: This bit enables the Received Data Available Interrupt (and timeout interrupt in the FIFO mode) when set to logic 1.

Bit 1: This bit enables the Transmitter Holding Register Empty Interrupt when set to logic 1.

Bit 2: This bit enables the Receiver Line Status Interrupt when set to logic 1.

Bit 3: This bit enables the MODEM Status Interrupt when set to logic 1.

Bit 4-7: These four bits are always logic 0.

Scratch Pad Register

This 8-bit Read/Write Register does not control the UART in anyway. It is intended as a scratch pad register to be used by the programmer to hold general purpose data temporarily.

FIFO Control Register

This write only register is located at the same address as the IIR (read only). This register is used to enable FIFO Mode, clear FIFO's, set the RCVr FIFO trigger levels, and select the mode of DMA signaling.

Bit 0: Writing a 1 to this bit enables both the XMIT and RCVr FIFO's. When changing from FIFO Mode to Character Mode and vice versa, data is not automatically cleared from the FIFO's. This bit must be a 1 when writing to other FCR bits or they will not be programmed.

Bit 1: Writing a 1 to FCR1 will reset its counters to 0, and then self clear this bit to 0. The shift register is not cleared.

Bit 2: Functions the same as bit 1, except for XMIT FIFO counters.

Bit 3: If FCRO=1, setting FCR# to a 1 will cause the RXRDY and TXRDY pins to change from mode 0 to mode 1 (see description of RXRDY and TXRDY pins).

Bit 4, 5: FCR 4 and FCR5 are reserved for future use.

Bit 6,7: FCR6 and FCR7 are used to set the trigger level for the RCVR FIFO interrupt as follows:

7	6	RCVR FIFO Trigger Level (In bytes)
0	0	01
0	1	04
1	0	08
1	1	14

MODEM Control Register

This 8-bit register controls the interface with the MODEM or data set (or a peripheral device emulating a MODEM). The contents of the MODEM Control Register are indicated in Table II and are described below:

Bit 0: This bit controls the Data Terminal Ready (DTR*) output. When bit 0 is set to a logic 1, DTR* output is forced to a logic 0. When bit 0 is reset to a logic 0, DTR* output is forced to a logic 1.

Note: the DTR* output of the UART may be applied to an EIA inverting line driver (such as DS1488) to obtain the proper polarity input at the succeeding MODEM or data set.

Bit 1: This bit controls the Request to Send (RTS*) output. Bit 1 affects the RTS* output in a manner identical to that bit 0 affects output DTR*.

Bit 2: This bit controls the internal OUTPUT 1 signal, which is an auxiliary user-designated output. Bit 2 affects the OIUTPUT 1 in a manner identical to bit 0 affects output DTR*. Internal OUTPUT1 signal is not connected the external pin.

Bit 3: This bit controls the internal OUTPUT2 signal, which is an auxiliary user-designated output. Bit 3 affects the OUT2* output in a manner identical to bit not connected to the external pin. When set, this bit enables INT2 pin internally.

Bit 4: This bit provides a local loopback feature for diagnostic testing of the UART.

When bit 4 is set to logic 1, the following occur. The transmitter Serial Output (SOUT) is set to a logic 1 (high) state: the receiver Serial Input (SIN) is disconnected; the output of the Transmitter Shift Register is "looped back" into the Receiver Shift Register input: the four MODEM Control inputs (CTS*, DSR*, RLS* and RI*) are disconnected. And the MODEM Control output pins (RST*, DTR*) are forced to their inactive state (high). In the diagnostic mode, data that is transmitted is immediately received. This feature allows the processor to verify the transmit-and receive-data paths of the UART.

In the diagnostic mode, the receiver and transmitter interrupts are full operational. Their sources are external to the part. The MODEM control Interrupts are also operational, but the sources of interrupts are now the lower four bits of the MODEM Control Register instead of the four MODEM control inputs. The interrupts are still controlled by the Interrupt Enable Register.

Bit 5-7: These bits are permanently set to logic 0.

MODEM STATUS Register

This 8-bit register provides the current state of the control lines from the MODEM or data set (or a peripheral device emulating a modem) to the CPU. In addition to this current-state information, four bits of the MODEM Status Register provide change information. These bits are set to a logic 1 whenever a control input from the MODEM changes state. They are reset to logic 0 whenever the CPU reads the MODEM Status Register.

The contents of the MODEM Status Register are indicated in Table II and described below:

Bit 0: This bit is the Delta Clear to Send (DCTS) indicator. Bit 0 when set to logic 1, indicates that the CTS* input to the chip has changed state since the last time it was read by the CPU.

Bit 1: This bit is the Delta Data Set Ready (DDSR) indicator, Bit 1 when set to logic 1, indicates that the DSR input to the chip has

changed state since the last time it was read by the CPU.

Bit 2: This bit is the Trailing Edge of Rin Indicator (TREI) detector. Bit 2 indicates that the RI input to the chip has changed from a low to high state since the last time it was read by the CPU.

Bit 3: This bit is the Delta Received Line Signal Detector (DRLSD) indicator. Bit 3 when set to logic 1, indicates that the RLSD input to the chip has changed state since the last time it was read by the CPU.

Note: Whenever bit 0, 1, 2, or 3 is set to logic 1, a MODEM Status Interrupt is generated, if bit 3 (EDSSI) of the interrupt enable register is set.

Bit 4: This bit is the complement of the Clear to Send (CTS*) input. This bit is equivalent to bit RTS of the MODEM control register, if bit 4 of the MCR is set to 1 (loop mode).

Bit 5: This bit is the complement of the Data Set Ready (DSR)* input. This bit is equivalent to bit DTR of the MODEM control register, if bit 4 of the MCR is set to 1(loop mode).

Bit 6: This bit is the complement of the Ring Indicator (RI)* input. This bit is equivalent to bit OUT1 of the MODEM control register, if bit 4 the MCR is set to 1 (loop mode).

Bit 7: This bit is the complement of the Received Line Signal Detect (RLSD) input. This bit equivalent to bit OUT2 of the MODEM control register, if bit 4 of the MCR is set to 1 (loop mode).

FIFO Interrupt Mode Operation

When the RCVR FIFO and receiver interrupts are enabled, (FCR0=1, IER0=1) RCVR interrupts will occur as follows:

A. The receive data available interrupt will be issued to the CPU when the FIFO has reached its programmed trigger level; it will be cleared as soon as the FIFO drops below its programmed

trigger level.

- B. The IIR receive data available indication also occurs when the FIFO trigger level is reached, and like the interrupt, it is cleared when the FIFO drops below the trigger level.
- C. The receiver line status interrupt (IIR=06), as before, has higher priority than the received data available (IIR=04) interrupt.
- D. The data ready bit (LSR bit 0) is set as soon as a character is transferred from the shift register to the RCVR FIFO. It is reset when the FIFO is empty.

When RCVR FIFO and receiver interrupts are enabled, RCVR FIFO timeout interrupts will occur as follows:

- A. A FIFO timeout interrupt will occur, if the following conditions exists:
 - at least one character is in the RCVR FIFO.
 - the most recent serial character received was longer than 4 continuous character times ago (if 2 stop bits are programmed the second one is included in this time delay).
 - the most recent CPU read of the FIFO was longer than 4 continuous character times ago.

This will cause a maximum character received to interrupt issued delay of 160 ms at 300 BAUD with a 12 bit character.

- B. character times are calculated by using the RCLK input for a clock signal (this makes the delay proportional to the baud rate).
- C. When a timeout interrupt has occurred, it is cleared and the timer is reset when the CPU reads one character form the RCVR FIFO.
- D. When a timeout interrupt has not occurred the ` timeout timer is reset after a new character is received or after the

CPU reads the RCVR FIFO.

When the XMIT FIFO and transmitter interrupts are enabled (FCR0=1, IER1=1), XMIT interrupts will occur as follows:

- A. The transmitter holding register interrupt (02) occurs when the XMIT FIFO is empty; it is cleared as soon as the transmitter holding register is written to (1 to 16 characters may be written to this XMIT FIFO while servicing this interrupt) or the IIR is read.
- B. The transmitter FIFO empty indications will be delayed 1 character time minus the last stop bit time whenever the following occurs: THRE=1 and there have not been at least two bytes at the same time in the transmit FIFO, since the last THRE=1, The first transmitter interrupt after changing FCR0 will be immediate, if it is enabled.

Character timeout and RCVR FIFO trigger level interrupts have the same priority as the current received data available interrupt; XMIT FIFO empty has the same priority as the current transmitter holding register empty interrupt.

FIFO Polled Mode Operation

With FCR0=1 RESETTING IER1, IER2, IERR3 or all to zero puts the UART in the RCVR and XMITTER are controlled separately either one or both can be in the polled mode of operation.

In this mode the users program will check RCVR and XMITTED status via the LSR. As stated previously:

LSR0 will be set as long as there is one byte in the RCVR FIFO.

LSR1 to LSR4 will specify which error(s) has occurred. Character error status is handled the same way as when in the interrupt mode, the IIR is not affected since IER2=0.

LSR5 will indicate when the XMIT FIFO is empty.

LSR6 will indicate that both the XMIT FIFO and shift register are empty.

LSR7 will indicate whether there are any errors in the RCVR FIFO.

There is no trigger level reached or timeout condition indicated in the FIFO Polled Mode. However, the RCVR and XMIT FIFO's are still fully capable of holding characters.

Parallel Port Description

The parallel port supports Centronics type printers. When CS2* is low, the parallel port is selected allowing access to all parallel port data, control and status registers.

PARALLEL PORT REGISTER ADDRESSES

Cs2*	A1	A0	IOR*	LOW*	Operation
0	0	0	0	1	Read Port Data Register
0	0	1	0	1	Read Port Status Register
0	1	0	0	1	Read Port Control Register
0	1	1	0	1	Invalid Operation
0	0	0	1	0	Write Port Data Register
0	0	1	1	0	Invalid Operation
0	1	0	1	0	Write Port Control Register
0	1	1	1	0	Invalid Operation

ACCESSIBLE PARALLEL PORT REGISTERS

Bit No	Port Data Register	Port Status Register (Read only)	Port Control Register
0	Data Bit 0	1	STBE
1	Data Bit 1	1	AFDE
2	Data Bit 2	1	INITE*
3	Data Bit 3	ERRORS*	SLINE
4	Data Bit 4	SLCTS	INTE
5	Data Bit 5	PES	1
6	Data Bit 6	ACKS*	1
7	Data Bit 7	BUSYS*	1

- Bits 0:2:** these bits are always read as 1.
- Bits 3:** Reports status of ERROR* pin.
- Bits 4:** Reports status of SLCT pin.
- Bits 5:** Reports status of PE pin.
- Bits 6:** Reports status of ACK*.
- Bits 7:** Reports inverted status of BUSY pin.

Port Control Register

This register controls output pins STB*, AFD*, INIT*, SLIN*, INT2. When read, it reports the status of the control pins.

Bits 0: This bit, when written 1/0, force STB* pin low/high.

Bits 1: This bit, when written 1/0, force AFD* pin low/high.

Bits 2: This bit, when written 1/0, force INIT* pin low/high.

Bits 3: This bit, when written 1/0, force SLIN* pin low/high.

Bits 4: This bit, when written 1/0, enables / disables INT2 pin.

Bits 5-7: Always read as 1.

Register Description

Port Data Register

This 8-bit data register can be modified by the CPU to write data to the parallel port.

Bits 0-7: Data bits

Port Status Register

This register is a read only register reporting the state of status input pins ERROR*, SLCT, PE, ACK*, and BUSY.

AC, DC TIMING SPECIFICATION

Absolute Maximum Ratings	
Temperature Under Bias	0 ⁰ c to +70 ⁰ c
Storage or Output Voltage	-65 ⁰ c to +150 ⁰ c
All Input or Output Voltages With Respect to VSS	-0.5 V to + 7.0 V
Power Dissipation	500 mw

If Military/Aerospace specified devices are required, contact Modular for availability and specifications. Note: Maximum rating indicate limits beyond which permanent damage may occur. Continuous operation at these limits is not intended and should be limited to those conditions specified under DC electrical characteristics.

DC ELECTRICAL CHARACTERISTICS

TA=0⁰C to + 70⁰c, Vcc=+5V±5%, Vss=0V, unless otherwise specified

Symbol	Parameter	Conditions	Min	Max	Units
VILX	Clock Input Low Voltage		-0.5V	0.8	V
VIHX	Clock Input High Voltage		2.0	Vcc	V
VIL	Input Low Voltage		-0.5V	0.8	V
VIH	Input High Voltage		2.0	Vcc	V
VOL	Output Low Voltage	IOL = 4.0 mA on D0-D7 = 12 mA on PD0-PD7 = 10 mA on INT*, AFD*, STB*, SLIN*(note1) = 2mA on all other OUTPUTS		0.4	V
VOH	Output High Voltage	IOH = -1.0 mA (note 1) = -2.0 mA on PD0-PD7 = -0.2 mA on INT*, AFD* STB*, SLIN* = -0.2mA on all other OUTPUTS	2.4		V
ICC(AV)	Avg. Power Supply Current(Vcc)	Vcc = 5.25V, f=4MHz No Loads on outputs SIN, DSR, DCD All other inputs = 0.8V		10	mA
IIL	Input Leakage	Vcc=5.25V, Vss=0V All other pins floating		±10	µA
ICL	Clock Leakage	VOUT = 0v, 5.25v		±10	µA
LOZ	Tri-State® Leakage	VCC=5.25V, VSS=0V VOUT = 0V, 5.25V 1) chip deselected 2) WRITE mode, chip selected		±10	µA
VILMR	MR Schmitt VIL		2.0	0.8	V
VIHMR	MR Schmitt VIH				V

CAPACITANCE

TA=25°C, VCC=VSS=0V

Symbol	Parameter	Conditions	Min	Typ	Max	Units
CXIN	Clock Input Capacitance	Fc = 1 MHz		15	20	pF
CXOUT	Clock Output Capacitance	Unmeasured pins Returned to VSS		20	30	pF
CIN	Input Capacitance			6	10	pF
COUT	Output Capacitance			10	20	pF

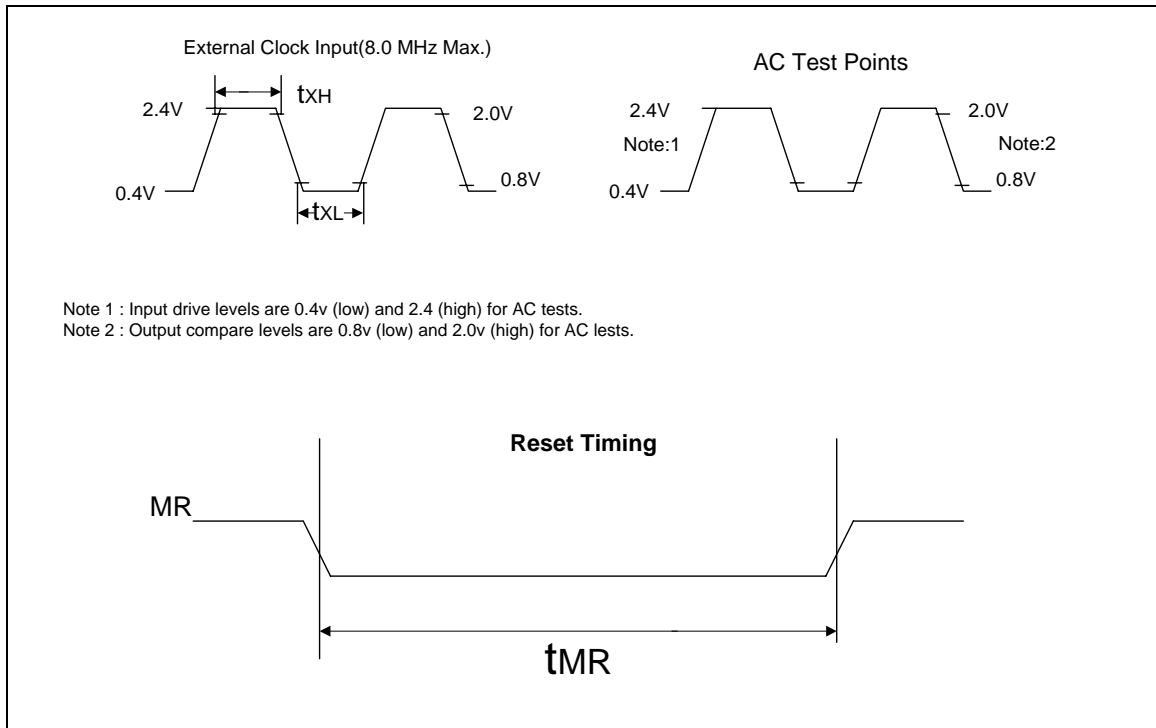

FIGURE 4 – Clock and Reset Timing

Symbol	Parameter	Min	Max	Units	Test Conditions
txh	Duration of External Clock High Pulse	55		nsec	External Clock (8.0 MHz Max)
txl	Duration of External Clock Low Pulse	55		nsec	1TTL Load (8.0 MHz Max)
tMR	Master Reset Pulse Width	5.0		nsec	1TTL Load

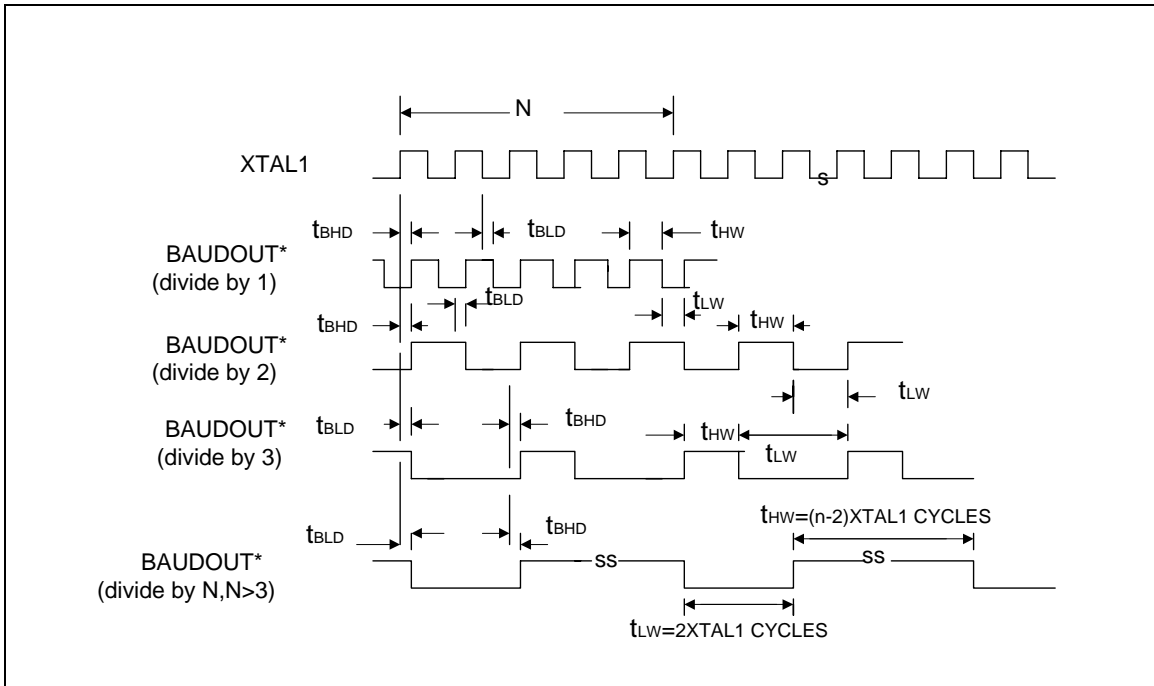

FIGURE 5 – Baud Rate General Timing

Symbol	Parameter	Min	Max	Units	Test Conditions
N	Baud Rate Divisor	1	$(2^{16}-1)$		
tBLD	Baud Output Negative Edge Delay		125	nsec	100pF Load
tBLD	Baud Output Positive Edge Delay		125	nsec	100pF Load
tLW	Baud Output Low Time	75		nsec	100pF Load
tHW	Baud Output High Time	100		nsec	100pF Load (fx=8.0 MHz+2)

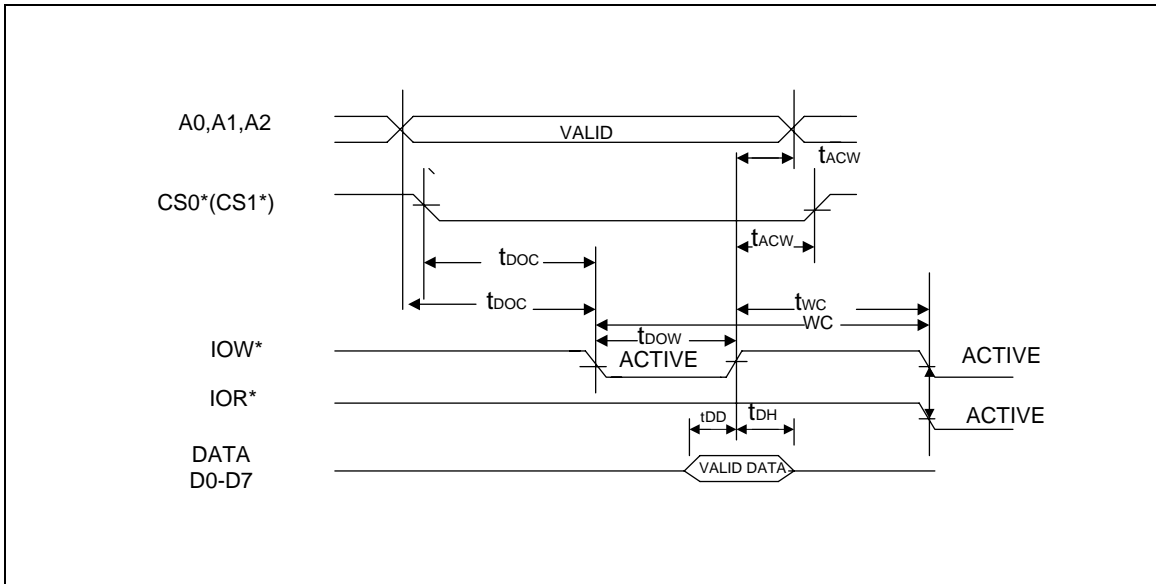

FIGURE 6 – Write cycle Timing

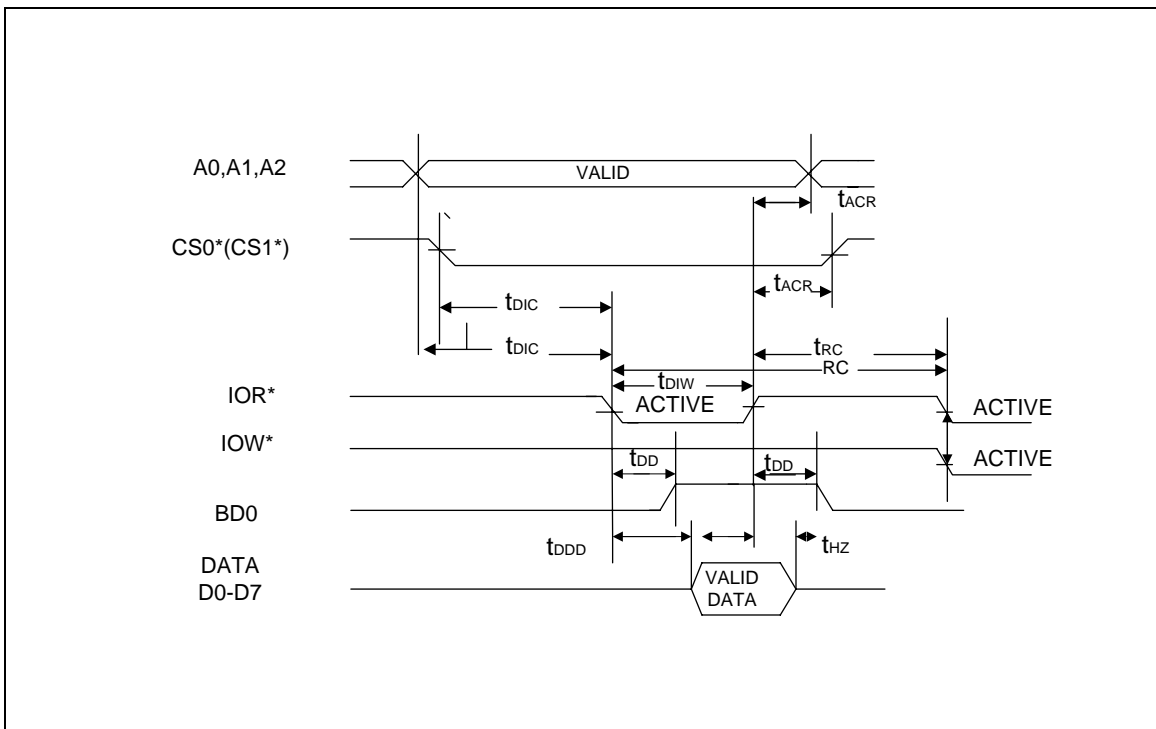

FIGURE 7- Read Cycle Timing

Symbol	Parameter	Min	Max	Units	Test conditions
TDIW	IOR* Strobe Width	50		nsec	1 TTL Load
RC	Read Cycle(tDIC + tDIW + tRC)	105		nsec	1 TTL Load
tDD	IOR* to Driver Enable/Disable Delay	0	60	nsec	@100pF Load
tDDD	Delay from IOR* to Data		40	nsec	@100pF Load
tHZ	IOR* to floating Data Delay	0	100	nsec	@100pF Load
tDOW	IOW* Strobe Width	50		nsec	1 TTL Load
WC	Write Cycle (tDOC + tDOW + tWC)	110		nsec	1 TTL Load
tDS	Data Setup Time	15		nsec	1 TTL Load
tDH	Data Hold Time	15		nsec	1 TTL Load
tDIC	IOR* delay from chip Select or Address	25		nsec	1 TTL Load
tDOC	IOW* delay from chip Select or Address	25		nsec	1 TTL Load
tACR	Address and Chip Select Hold time from IOR*	2		nsec	1 TTL Load
tACW	Address and Chip Select Hold time from IOW*	2		nsec	1 TTL Load
tWC	Write Cycle Delay	60		nsec	1 TTL Load
tRC	Read Cycle Delay	50		nsec	1 TTL Load

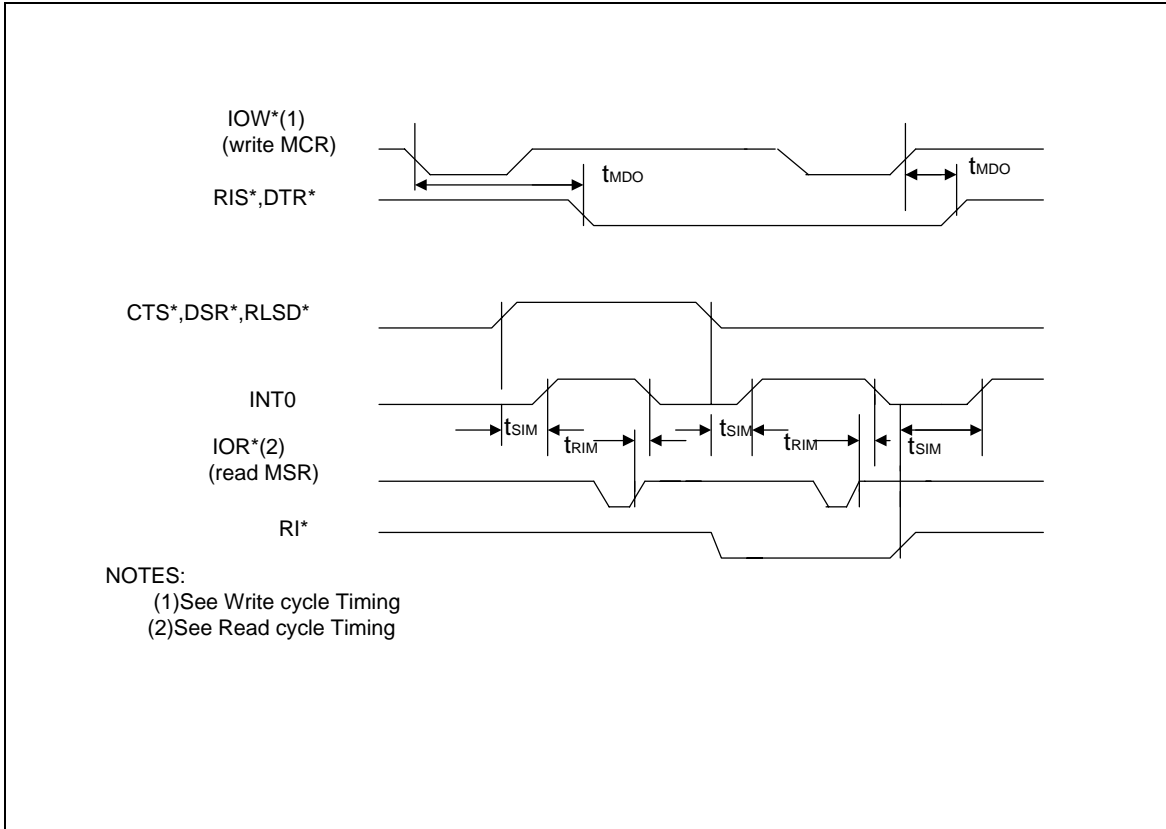

FIGURE 8 – Modem Control Timing

Symbol	Parameter	Min	Max	Units	Test Conditions
tMDO	Delay from IOW* (WR MCR)		200	nsec	100pF Load
tSIM	Delay to Set Interrupt From MODEM Input		200	nsec	100pF Load
tRIM	Delay to Reset Interrupt From IOR* (RD MSR)		30	nsec	100pF Load

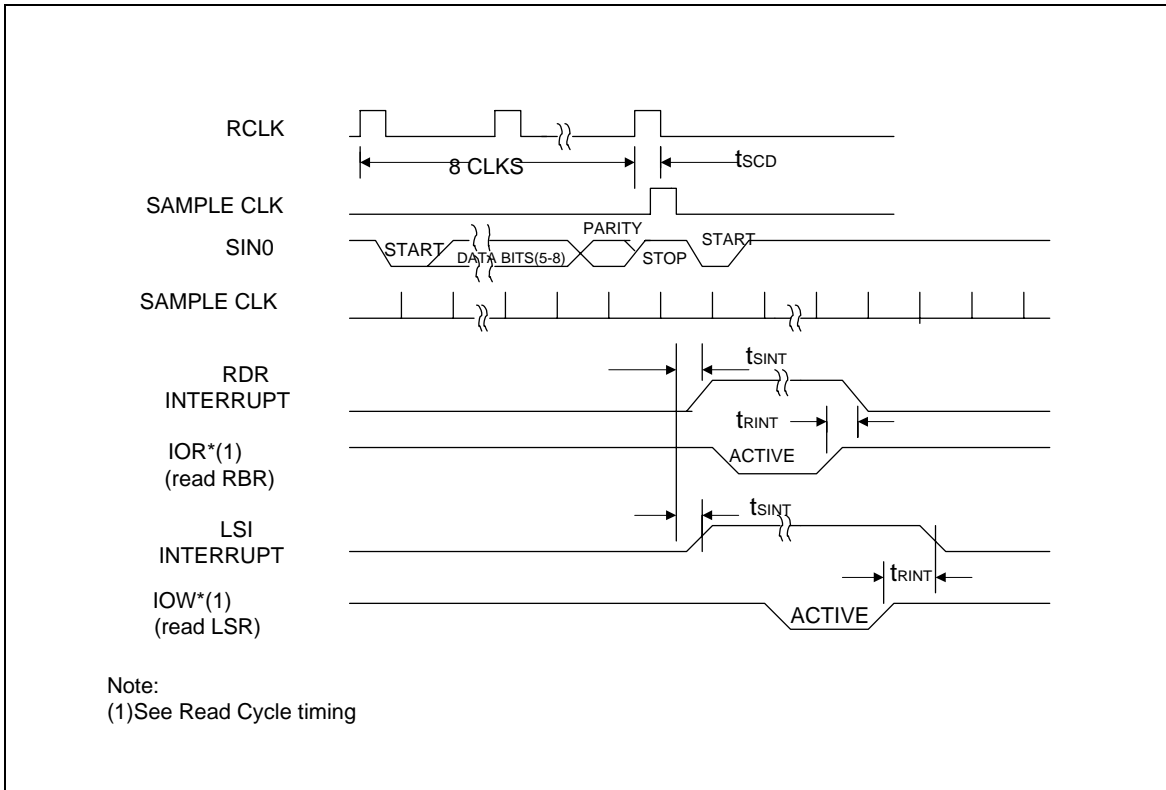

FIGURE 9 – Receiver Timing

Symbol	Parameter	Min	Max	Units	Test Conditions
t_{SCD}	Delay from RCLK To Sample Time		2	μ sec	
t_{SINT}	Delay from Stop to Set Interrupt		1(*)	RCLK Cycles	
t_{RINT}	Delay From IOR* (RD RBR or RD LSR) Reset Interrupt		32	nsec	100pF Load

(*) When receiving the first byte in FIFO mode t_{SINT} will be delayed 3 RCLK cycles, except for a timeout interrupt where t_{SINT} will be delayed 8 RCLK cycles.

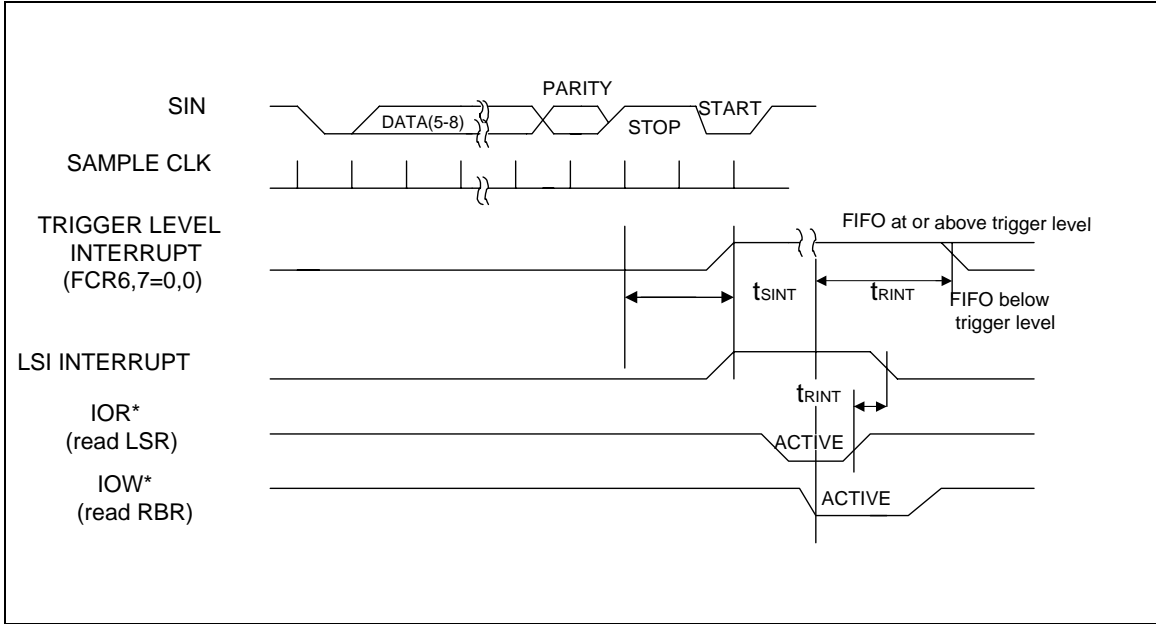

FIGURE 10 – RCVR FIFO Timing for First Byte

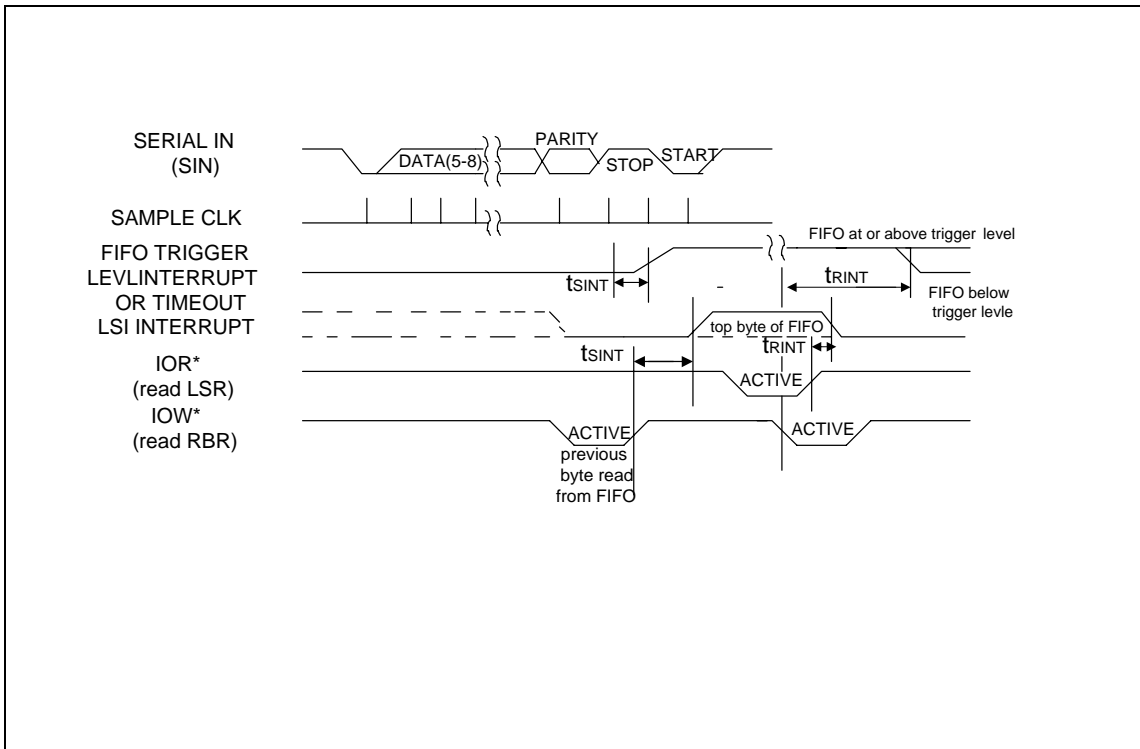
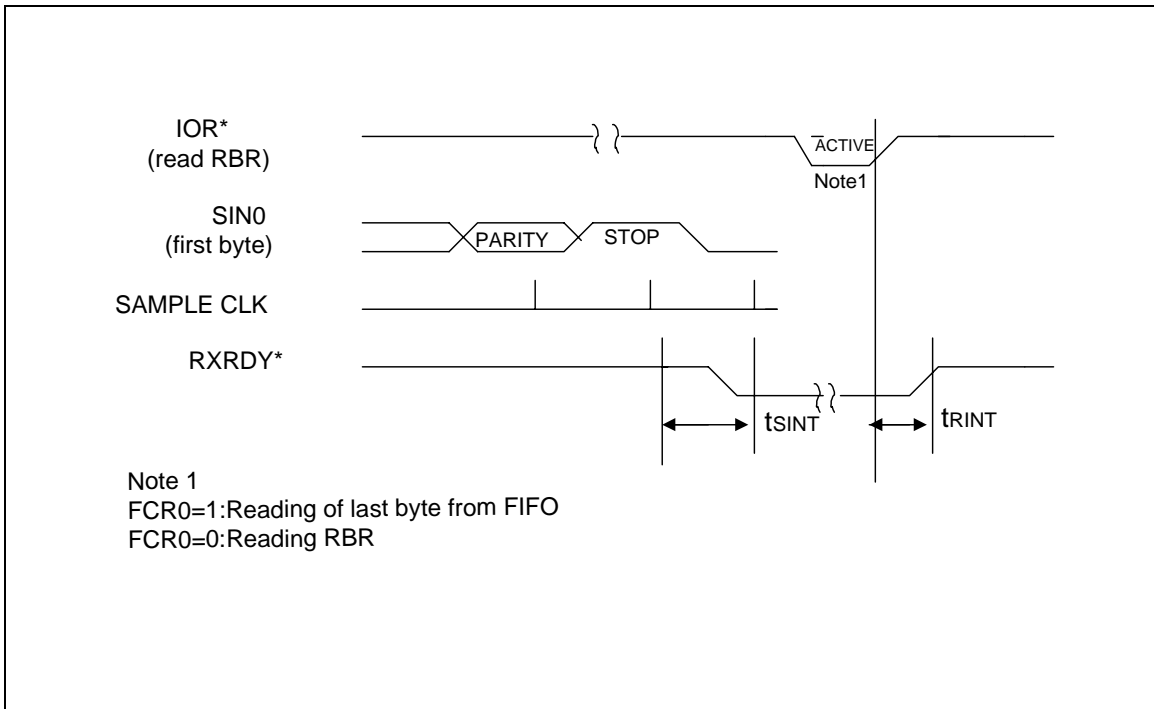
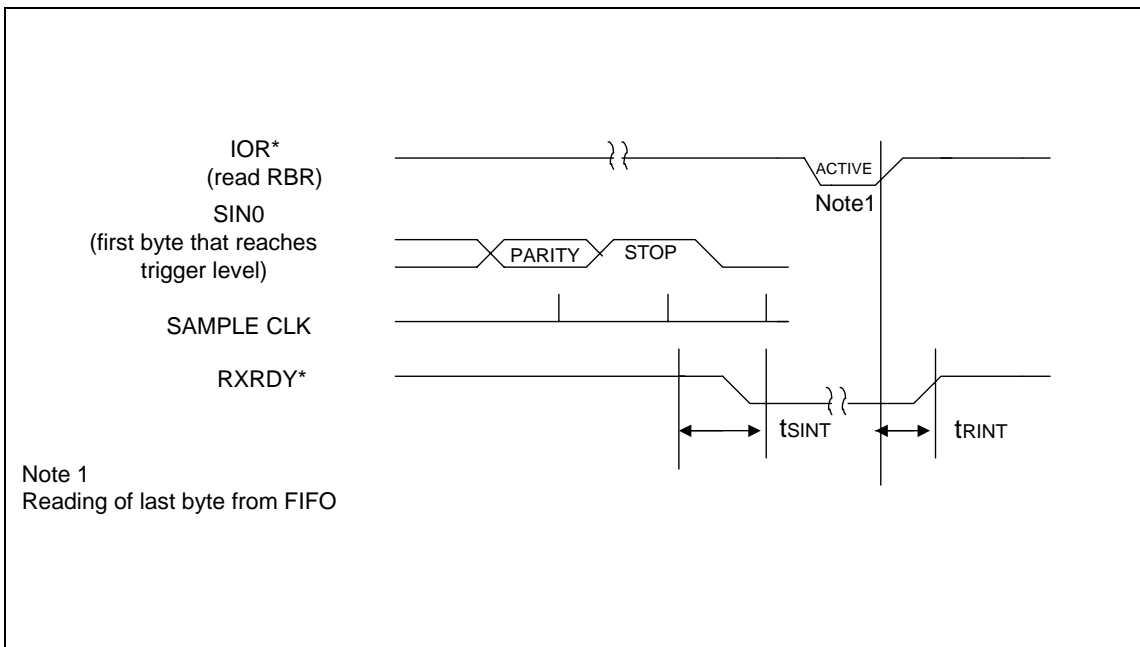

FIGURE 11 – RCVR FIFO Timing after First Byte(RDR already set)



**FIGURE 12 – Receiver DMA Timing (FCR0=0 or FCR0=1 and FCR3=0)
Mode 0**



**FIGURE 13 – Receiver DMA Timing (FCR0=1 and FCR3=1)
Mode 1**

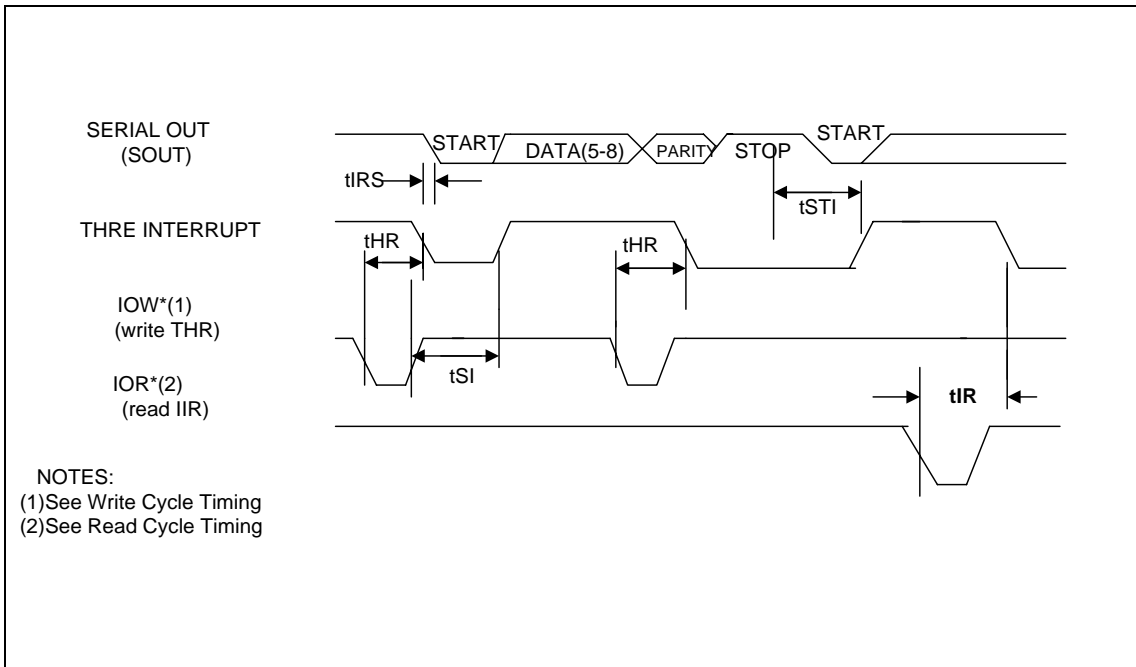
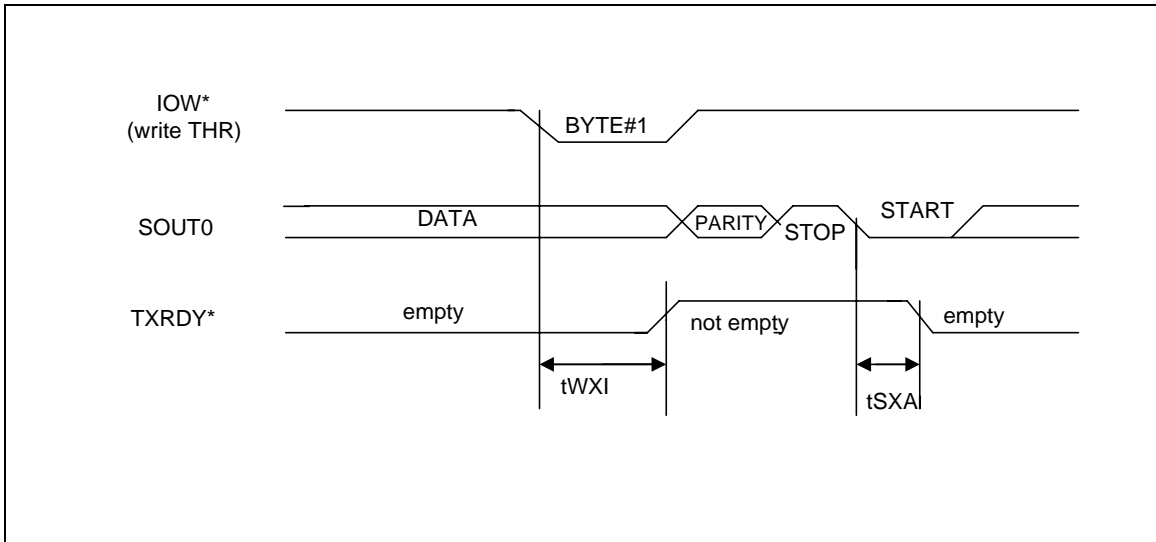
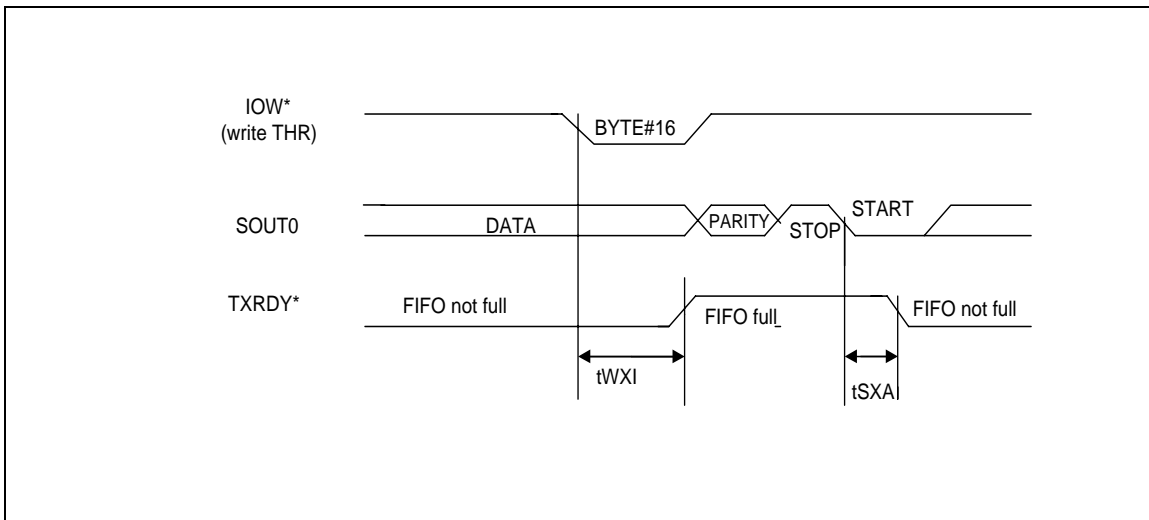

FIGURE 14 – Transmitter Timing

Symbol	Parameter	Min	Max	Units	Test Conditions
tHR	Delay from IOW* (WR THR) to Reset Interrupt		50	nsec	100pF Load
tIR	Delay from IOR* (RD IIR) to Reset Interrupt(THRE)		250	nsec	100pF Load
tIRS	Delay from Initial INTRPT reset to transmit Start	0	12	BAUDOUT Cycles	
tSI	Delay from Initial Write to Interrupt	16	32	BAUDOUT Cycles	(note 1)
tSTI	Delay from Stop to Interrupt(THRE)	8	8	BAUDOUT Cycles (note 1)	(note 1)
tSXA	Delay from Start to TXREY Active	0	8	BAUDOUT Cycles	100pF Load
tWXI	Delay from Write to TXRDY Inactive	0	60	nsec	100pF Load



**FIGURE 15-Transmitter Ready Timing in DMA
(FCR0=0 or FCR0=1 and FCR3=0)
Mode 0**



**FIGURE 16-Transmitter Ready Timing in DMA
(FCR0=0 or FCR0=1 and FCR3=0)
Mode 1**

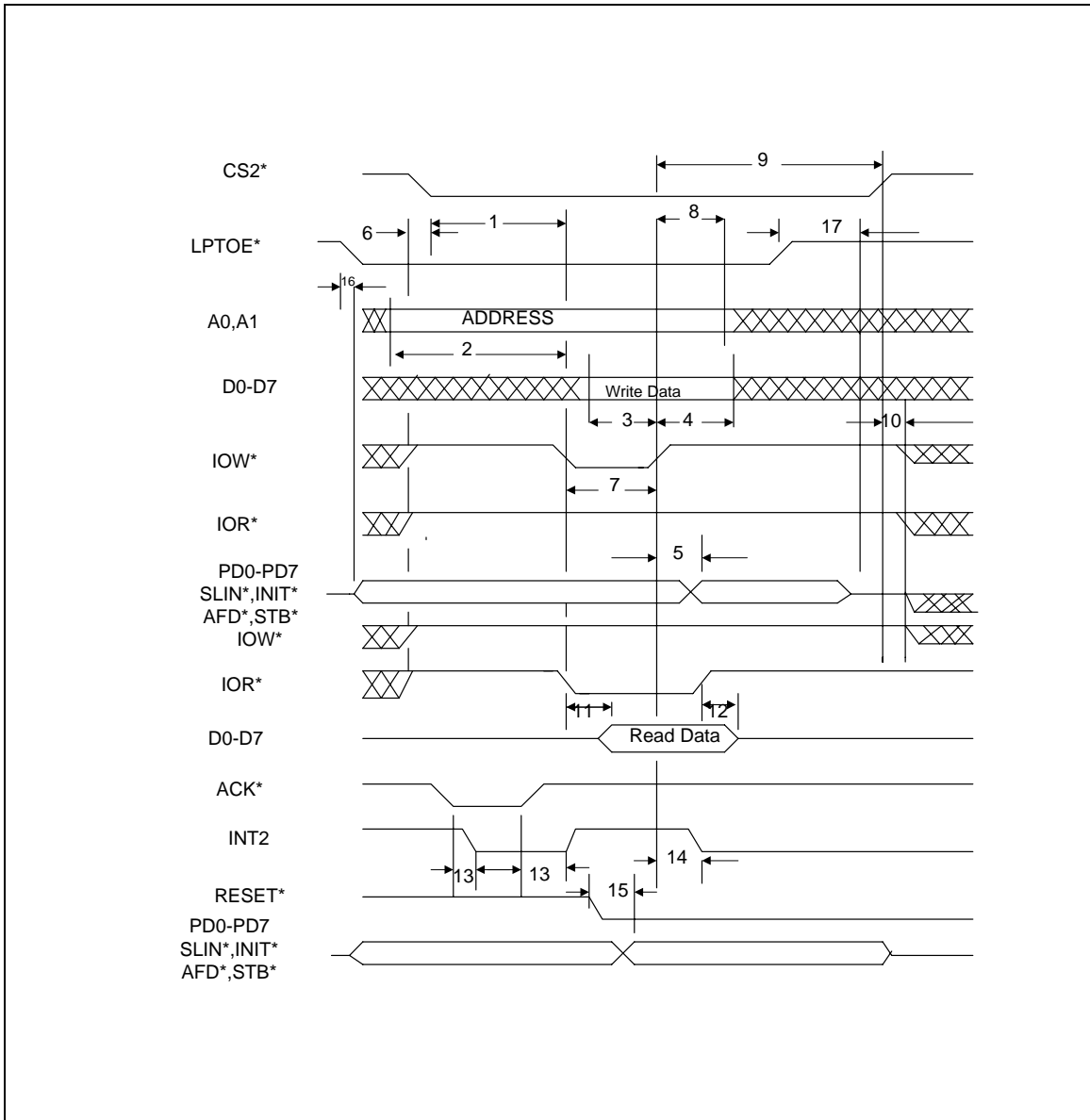

FIGURE 17- Parallel Port Timing

Symbol	Parameter	Min	Max	Units	Test Conditions
1	CS2* low to IOR*, IOW* low	30		ns	
2	Address valid to IOR*, IOW* low	30		ns	
3	Data setup to IOW* high	30		ns	
4	Data hold to IOW* high	30			
5	IOW* high to PD0-PD7		100	ns	
	IOW* high to INIT*, AFD*, SLIN*, STB*		100	ns	
6	IOW*, IOR* high to CE* low	0		ns	
7	Pulse width IOW* low	100		ns	
8	Address hold after IOW*, IOR* high	20		ns	
9	CS2* hold after IOW* IOR* high	0		ns	
10	IOW* IOR* hold after CS2* high	10		ns	
11	IOR* low to data valid		125	ns	
12	IOR* high to D7-D0. Hi-Z		100	ns	
13	ACK* to INT2		50	ns	
14	IOW* high to INT2 Hi-Z		60	ns	
15	RST* low to D7-D0, SLIN*, STB* INIT*, AFD*		65	ns	
16	LPTOE* low to PD0-PD7 Delay		50	ns	
17	LPTOE* high to PD0-PD7Hi-Z		100	ns	

ORDERING INFORMATION

Part Number

IMP16C552-CJ68

IMP16C552-IJ68

Package

68 pin PLCC

68 pin PLCC

Operating Temperature

0 +70

-40 +85