INTRODUCTION

With the continuing demand for smaller and more efficient systems, designers are seeking new ways to reduce power and increase integration. This paper describes how good use of OKI Semiconductor's monolithic display drivers can reduce power consumption and component count in systems that incorporate liquid crystal displays (LCDs). Information in this paper is applicable both to small LCD panels (with a dozen or less segmented digits) and to large LCD panels (such as used for laptop screens).

LCD elements are capacitive in nature and dissipate virtually no power, whether selected or deselected. When an LCD element is selected, a voltage is applied across the liquid crystal that varies the element's reflectivity. Removing the voltage deselects the LCD element and returns the liquid crystal to its original state.

In general, an alternating-current (AC) source is required to illuminate the individual elements in an LCD panel. A direct-current (DC) source is not suitable for driving an LCD panel because of electrolytic reactions in the LCD's liquid. Placing a potential difference across the liquid in an LCD panel causes ion migration, which gradually erodes the anode terminal and causes destructive deposition on the cathode terminal. The electrolytic reaction could be diminished by plating the electrodes with a non-reactive conductive element, such as gold, for example; however, the high cost of gold and similar non-reactive elements makes this solution impractical for all but the most esoteric applications.

A far simpler way to eliminate electrolytic corrosion is to use an AC source to drive the LCD panel, eliminating unidirectional ion migration and the associated problems. AC configurations for driving LCDs fall in two main categories, which are:

- Static driver configurations
- Multiplexed driver configurations

The next two sections describe these two configurations. The third section in this application note addresses power-related issues. This application note concludes with some complete circuit examples.

USING STATIC DRIVERS

In configurations using static drivers, a separate driver signal (SEG) provides an AC source for each element, and all elements use a single shared common (COM) terminal.

LCD elements are often *segments* of an alphanumeric digit. In larger configurations, LCD elements are individual *dots* that emulate the appearance of a CRT monitor. Static driver configurations are simple to use and are generally suitable for LCDs with less than 80 segments.

OKI Semiconductor supplies a range of single-chip solutions for static LCD driver configurations, some of which also include built-in RC oscillation circuits, in small-outline IC (SOIC) and plastic quad flat pack (PQFP) packages. The table below lists the main characteristics of single-chip static LCD drivers from OKI Semiconductor.

LCD Drivers for Static Configurations

Part Number	Segments	On-Chip Oscillator	Drive Voltage (V_{LCD})	Package
MSM5219B	48	√	4.0 - 7.0	60-lead PQFP
MSM5221	56	X	3.0 - 7.0	80-lead PQFP
MSM5265	80	√	3.0 - 6.0	100-lead PQFP

Figure 1 below shows static driver connections to a single-digit, seven-segment alphanumeric display. Separate drivers, SEG1 - SEG8, power each segment. All segments share a common ground connection, COM.

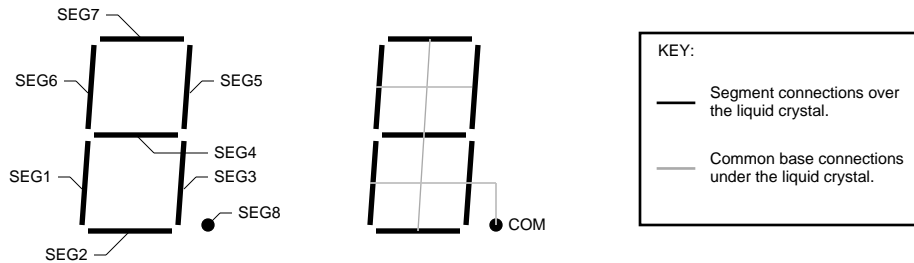

Figure 1. Segment Connections for Static-Drive Configurations

Figure 2 below shows the AC waveforms for driving the illustrated display. When an element is deselected, the combined COM and SEG signals negate each other, as shown for the (COM – SEG1) signal illustrated below. When an element is selected, the combined COM and SEG signals constructively reinforce each other, as shown for the (COM – SEG2) signal below.

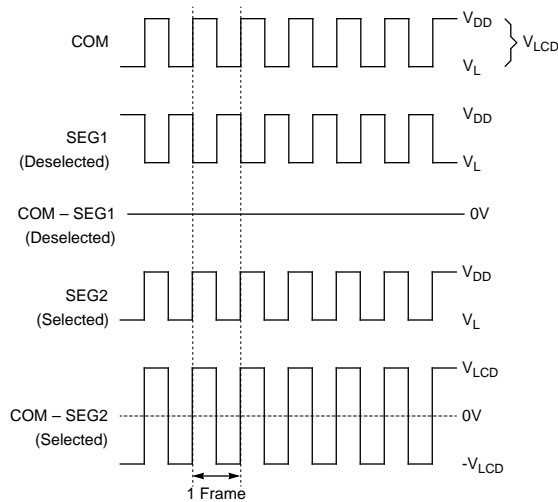

Figure 2. Functional Waveforms for Static Drive Configurations

In static drive configurations, the AC frequency used to drive each segment is identical. This AC frequency is called the *frame frequency*. In static drive configurations, a single element is selected or deselected in any one individual frame, as shown in Figure 2 above.

Static driver configurations generally use a frame frequency in the 20-200 Hz range. Lower frame frequencies can cause visible flicker. Higher frame frequencies do not provide sufficient time for charging the capacitive LCD elements.

USING MULTIPLEXED DRIVERS

For configurations requiring more than about 80 drivers, it is more efficient to multiplex the COM and SEG signals than to use a static driver configuration. In multiplexed configurations, each SEG driver signal powers more than one segment, and the circuit uses more than one COM signal. The SEG and COM signals actually form a grid, with each segment driven by a unique SEG/COM node. The multiplexed drive method reduces the number of driver circuits and the number of connections between the circuit and the display cell. This reduces cost when driving many display elements.

Figure 1 below illustrates this reduction in driver count by comparing static and multiplexed drive configurations for a six-digit display. The static driver configuration requires 49 connections to the LCD, whereas the multiplexed configuration requires only 21 connections. Increasing the degree of multiplexing can further reduce the number of connections; however, increased multiplexing also reduces the circuit's tolerance to voltage variation.

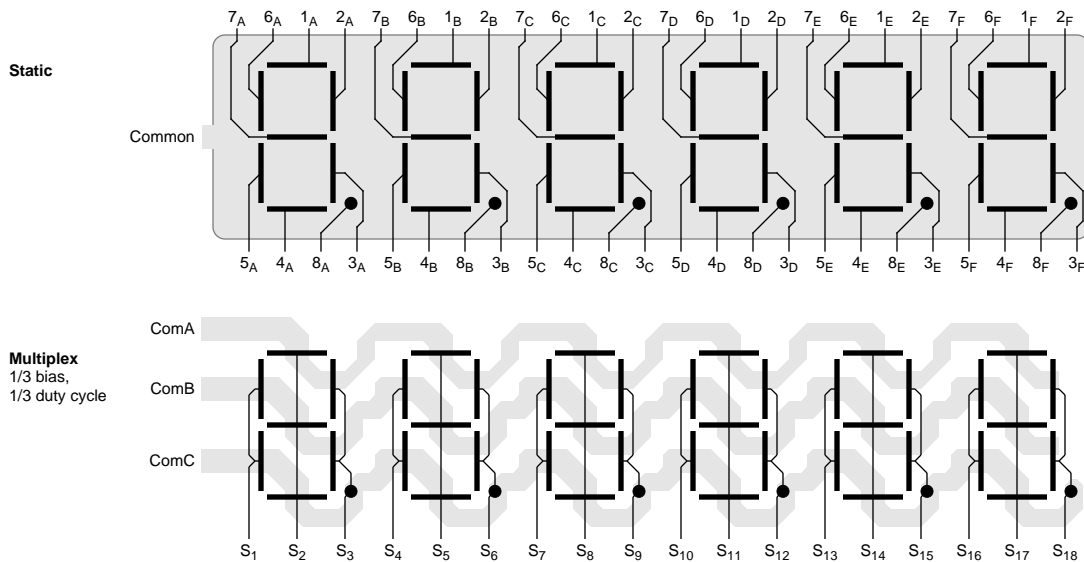

Figure 3. Static versus Multiplexed Configurations

A range of multiplexed configurations are possible, distinguished by:-

- *Bias*, indicating the number of voltage levels used to power the LCD display.
- *Duty Cycle*, indicating the number of segments driven by each individual output driver.
- *Frame Frequency Type*, indicating whether the COM signal alternates over one frame (Type A) or two frames (Type B).

For example, in a 1/2 bias, 1/2 duty-cycle configuration, each individual output driver uses two voltage levels to drive two segments. Similarly, in a 1/3 bias, 1/3 duty-cycle configuration, each driver uses three voltage levels to drive three segments (Figure 1 above is a 1/3 bias, 1/3 duty cycle configuration).

Frame frequency determines the degree of flickering and vividness. For a high degree of multiplexing, the type-B configuration can make the display more vivid, but can also introduce flickering at lower clock frequencies. Figure 4

and *Figure 5* below illustrate the difference between type-A and type-B configurations for the LCD driver network shown in *Figure 1* above.

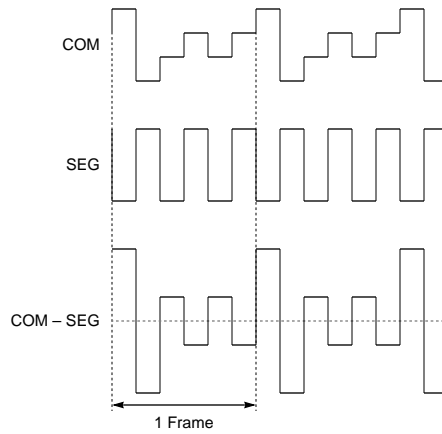

Figure 4. A-Type Waveforms for a 1/3 Duty Cycle, 1/3 Bias Configuration

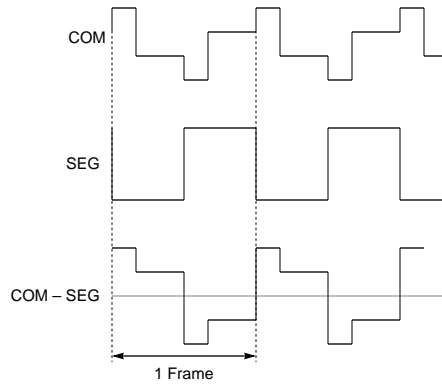

Figure 5. B-Type Waveforms for a 1/3 Duty Cycle, 1/3 Bias Configuration

Type B configurations are more common, as the maximum required frequency is lower. *Figure 6* through *Figure 10* illustrate various multiplexed configuration, all of which use a Type B configuration to reduce frame frequency.

Figure 6 on the next page illustrates how a 1/2 bias, 1/2 duty cycle, Type B configuration can drive 62 outputs. This particular example is suitable for systems using the MSM6660. Full V_{LCD} voltage is applied across the selected segment for display and less than full V_{LCD} voltage is applied across the deselected segment.

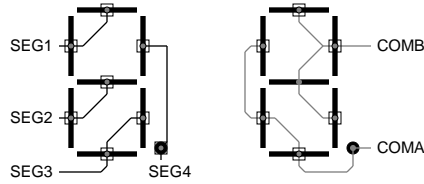
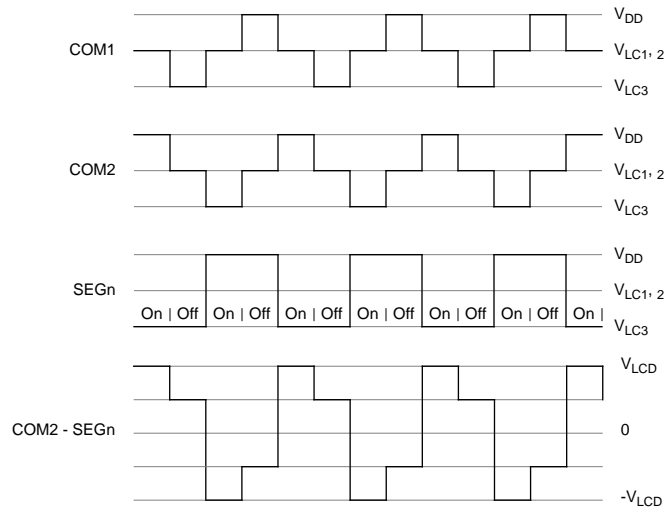

Figure 6. A 1/2 Bias, 1/2 Duty Cycle, Type B Configuration

Figure 7 below shows the waveforms for the 1/2 bias, 1/2 duty cycle configuration shown in Figure 6 above.



Note: When 1/2 duty is selected and 1/2 bias is used, perform the following:
 When the code is -01, short VLC1 and VLC2 to supply the bias voltage.
 When the code is -02 or -03, externally short VLC1 and VLC2.

Figure 7. Waveforms for 1/2 Bias, 1/2 Duty Cycle, Type B Configuration

Figure 8 illustrates a 1/3 bias, 1/3 duty cycle, Type B LCD network, suitable for connection to OKI's MSM6606.

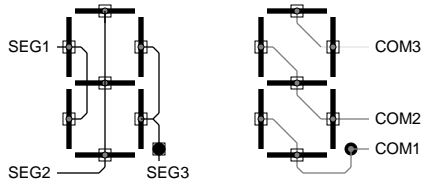

Figure 8. 1/3 Duty Cycle, 1/3 Bias, Type B Configuration

Figure 9 below depicts waveforms for the 1/3 bias, 1/3 duty cycle, Type B network in Figure 8 above.

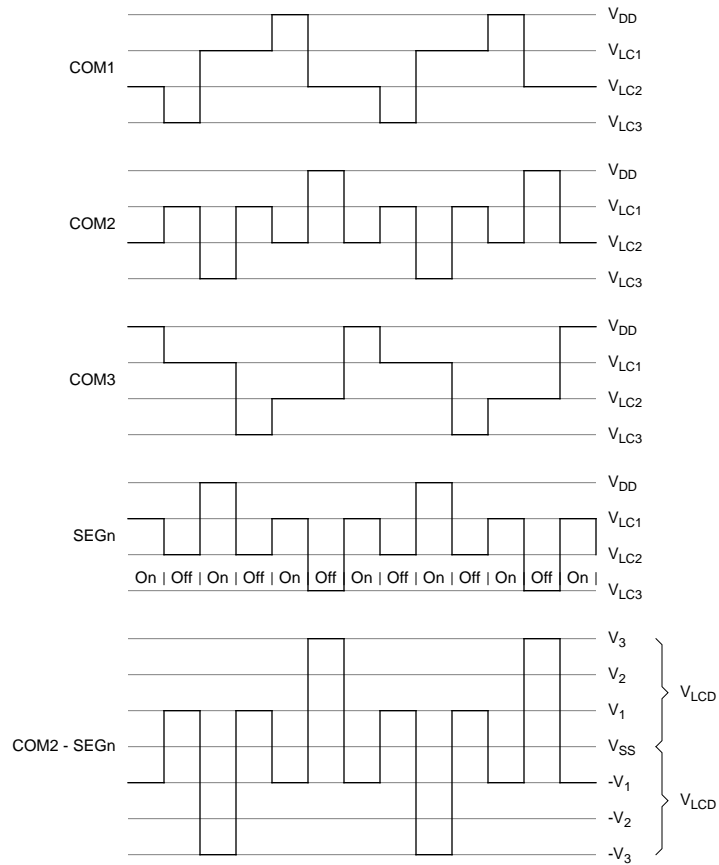

Figure 9. 1/3 Duty Cycle, 1/3 Bias, Type B Waveforms

Figure 10, below, illustrates a 1/5 bias, 1/16 duty cycle, Type B configuration, together with COM and SEG waveforms. This example uses the dot-matrix configuration for display.

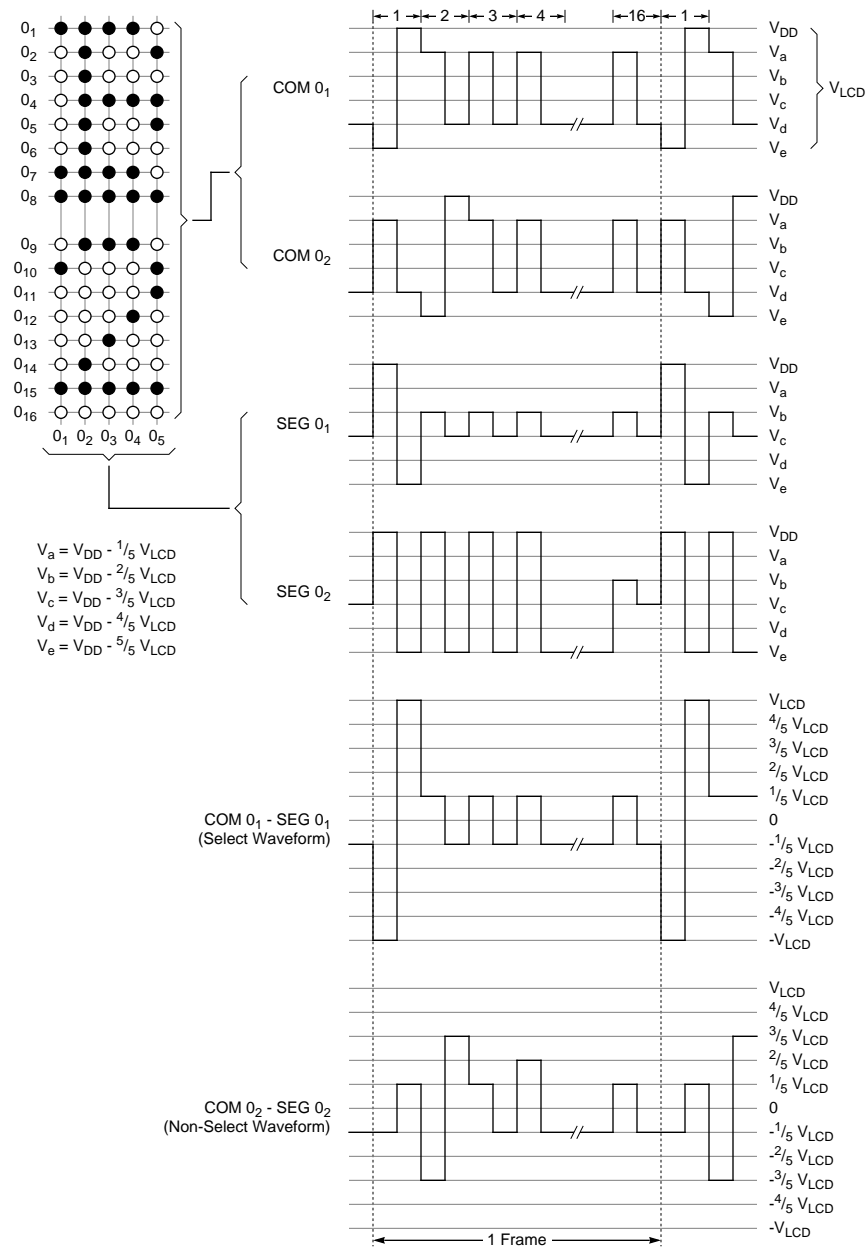

Figure 10. A 1/5 bias, 1/16 duty cycle, Type B Configuration and Waveforms

Larger configurations are simply extensions of the above principles. OKI Semiconductor supplies a range of single-chip and multi-chip solutions for multiplexed LCD driver configurations supporting any required number of dots or segments. The table below lists single-chip LCD drivers, indicating major differences for each part.

Single-Chip LCD Drivers for Multiplexed Configurations

Part Number	Dots	Duty Cycle Ratio	On-Chip Oscillator	Drive Voltage (V _{LCD})	Package
MSM6544	42	1/2	√	3.0 - 6.0	56-lead PQFP
MSM6606	40	1/2	X	4.5 - 5.5	64-lead PQFP
MSM6660-01	62	1/2	X	4.0 - 6.0	80-lead PQFP
MSM6660-02	62	1/3	X ^[1]	4.0 - 6.0	80-lead PQFP
MSM6660-03	62	1/3	X ^[1]	4.0 - 6.0	80-lead PQFP
MSM5265	80	1/2	√	3.0 - 6.0	100-lead PQFP
MSM5260	80	1/32 - 1/64	X	8.0 - 18.0	100-lead PQFP
MSC5301B-01	16 COM 64 SEG	1/16	X	4.0 - 16.0	100-lead PQFP
MSC5301B-02	8 COM 64 SEG	1/8	X	4.0 - 16.0	100-lead PQFP

[1] On-chip bias resistors.

For larger dot configurations, such as found in laptop displays for example, common and segment drivers are located on separate chips.

The table below shows critical features for ICs that provide common drivers only. Note the use of thin quad flat packs (TQFPs) and Tape Automated Bonding (TAB) for devices with higher lead counts.

Common Drivers for Multiplexed Configurations

Part Number	Drivers	Duty Cycle Ratio	Max. Dots	Drive Voltage (V _{LCD})	Package
MSM5238	32	1/32 - 1/64	2,048	3.0 - 16.0	44-lead PQFP
MSM5298A	68	1/64 - 1/256	17,408	8.0 - 28.0	80-lead TQFP
MSM6368	80	1/256 - 1/480	38,400	25.0 - 40.0	100-lead TQFP

The next table, opposite, shows the same critical features for ICs that provide segment drivers only.

Segment Drivers for Multiplexed Configurations

Part Number	Drivers	Duty Cycle Ratio	Max. Dots	Inputs	Drive Voltage (V _{LCD})	Package
MSM5259	40	1/8 - 1/16	640	1	3.0 - 6.0	56-lead PQFP
MSM5839B	40	1/32 - 1/128	5,120	1	8.0 - 18.0	56-lead PQFP
MSM5839C	40	1/3 - 1/64	2,560	1	4.0 - 11.0	56-lead PQFP
MSM5299A	80	1/64 - 1/256	20,480	4	8.0 - 28.0	100-lead PQFP

Segment Drivers for Multiplexed Configurations (Continued)

Part Number	Drivers	Duty Cycle Ratio	Max. Dots	Inputs	Drive Voltage (V _{LCD})	Package
MSM5299A-01	80	1/64 - 1/256	20,480	4	8.0 - 28.0	100-lead TQFP
MSM5299C	80	1/64 - 1/256	20,480	4	8.0 - 28.0	100-lead PQFP
MSM6669	80	1/100 - 1/256	20,480	4	14.0 - 28.0	0.25mm TAB

POWER SUPPLY

The table below shows the relationship between the required number of driving biases and the display duty ratios.

Relationship between Duty Cycle and Driving Bias

Duty Ratio	Drive Bias	Voltage Levels
Static	–	2
1/2	1/2	3
1/3	1/3	4
1/4	1/3	4
1/7	1/4	5
1/8	1/4	5
1/11	1/4	5
1/12	1/4	5
1/14	1/5	6
1/16	1/5	6
1/24	1/5	6
1/32	1/5	6
1/64	1/5	6

Either passive or active bias generation circuitry can provide the required voltage levels, as described in the next two subsections.

Passive Bias Generation

A resistor ladder is the most common way to generate the required bias voltage levels. *Figure 11* below shows a typical resistor ladder. V_{REF} may be tied to V_{SS}, or, for displays with larger voltage bias ranges, V_{REF} may be tied to a negative power source.



Figure 11. Network for Simple Passive Bias Generation

The required operating margin and power consumption determines the appropriate resistor values. Because the LCD load is capacitive, the current during element charging and discharging distorts the waveform. Generally, the value of resistor R is 1 k Ω to 10 k Ω . Lower resistor values reduce distortion but increase power dissipation. Larger LCD panels exhibit greater capacitance, and so resistor values may be decreased proportionally as the display size increases.

No capacitor is required, but a 1- μ F capacitor can be used if necessary. Connecting a capacitor in parallel to the resistors can reduce waveform distortion during the charge and discharge periods, but only to a limited degree. Larger capacitor values generate a voltage level shift and reduce the operating margin. *Figure 12* below illustrates how to connect capacitors in a passive bias network.

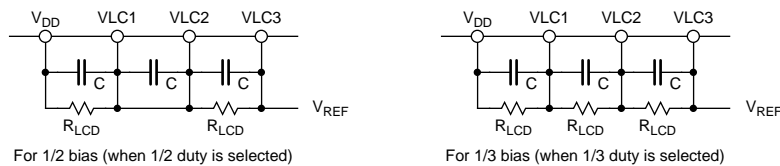

Figure 12. Network for Passive Bias Generation with Capacitor Filters

In large arrays, the LCD source and common signals form a matrix configuration that complicate the path of the charge/discharge current through the load. Moreover, current varies according to the demand for the power consumption of the equipment in which the LCD is incorporated. As a result, it is not possible to generate precise equations for calculating resistor and capacitor values.

Active Bias Generation

In larger displays, such as graphic displays, the liquid crystal is larger and the duty cycle ratio is smaller. Stability of the liquid crystal's drive level is therefore more important for a large display than for a small display.

Because graphic displays are large and contain many picture elements, the LCD driver's impedance produces distortion in the drive waveforms and degrades display quality. For this reason, the impedance of the LCD driver bias sources should be reduced with operational amplifiers. *Figure 13* below shows examples of op amp configurations to provide this reduced impedance.



Figure 13. Network for Active Bias Generation

No load current flows through the dividing resistors because of the high input impedance of the operational amplifiers. A resistor value for R of 10 kΩ is suitable for the above circuit.

APPLICATION CIRCUITS

This application note concludes with two illustrative application circuits. The first, shown in *Figure 14* below, uses two MSM6660 LCD drivers to provide three bias signals and 124 segment drivers for a 1/3 bias, 1/3 duty cycle, Type B LCD panel containing 372 dots.

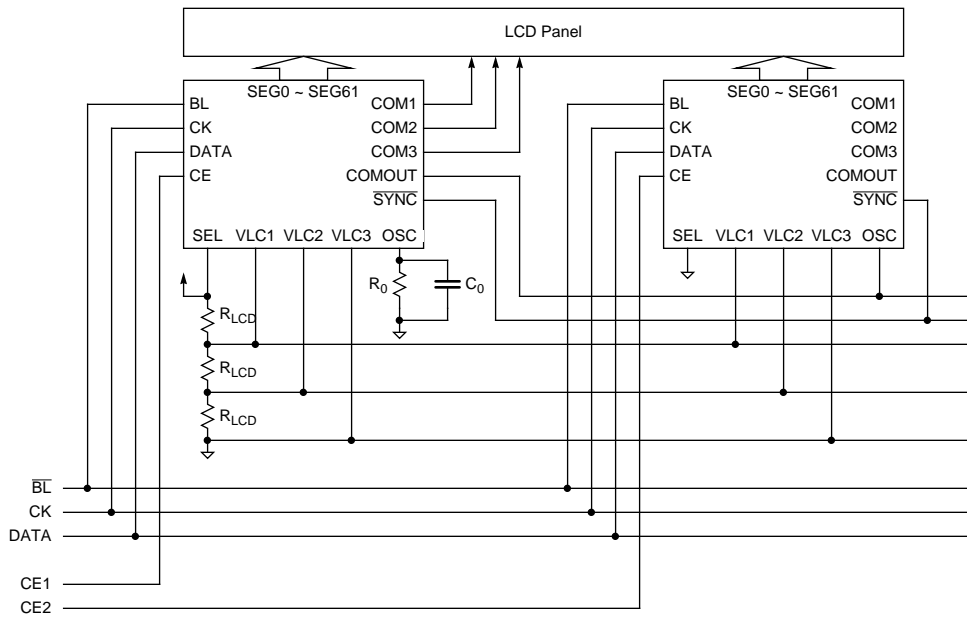

Figure 14. Application Circuit Example Using MSM6660 LCD Drivers

In the example on the previous page, a microcontroller may be necessary to provide an appropriate interface to the overall system. *Figure 15* below depicts a more complex example that may not require an additional microcontroller.

Instead of using a separate LCD driver and microcontroller, this circuit integrates LCD driver and controller functions in the MSM6222GS LCD Controller, available from OKI Semiconductor.

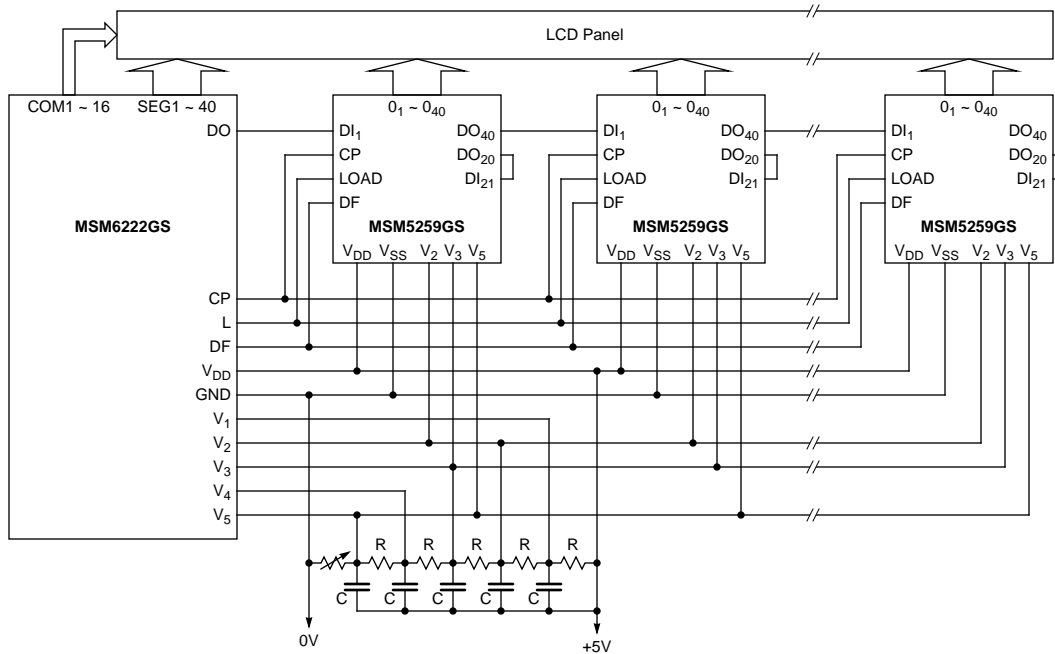

Figure 15. Typical Application Circuit Using the MSM6222GS LCD Controller

LCD controllers can increase system integration and provide a more comprehensive feature set. For small and mid-size displays, a single LCD controller may provide all the required COM and SEG signals. For larger configurations, combinations of LCD controllers and drivers can provide exactly the required degree of functionality. In the above example, the LCD controller provides all required COM signals and some of the SEG signals. Additional SEG drivers augment the LCD controller with the additional SEG drivers required.

OKI Semiconductor provides a family of advanced LCD controllers and drivers that augment the basic functionality of standard LCD drivers and controllers with enhanced capabilities. Additional features found in OKI's LCD controllers include key-scan logic, power saving modes, on-chip RAM, integrated oscillators, and optional on-chip bias generation. The table on the following page lists some of the members of OKI's advanced LCD controller/driver family.

The following table lists the main features of devices in OKI's advanced LCD controller/driver family described in this document.

OKI's Advanced LCD Controller/Driver Family

Part No.	Controller	Drivers	Duty Cycle	V _{LCD}	Interface	Pins / Package	Special Features
MSM5298A	—	68 COM	1/64 - 1/256	8.0 - 28.0	Serial shift register I/O	80/ PQFP	Bidirectional 68-bit shift register Multi-chip configuration support On-chip or external bias generation
MSM5299A	—	80 SEG	1/64 - 1/256	8.0 - 28.0	4-bit shift register I/O	100/ PQFP	Bidirectional 4x20-bit shift register 80-bit latch Multi-chip configuration support On-chip or external bias generation
MSC5301B-01	—	64 SEG 16 COM	1/16 (1/5 bias)	4.0 - 16.0	Serial MCU interface	100/ PQFP	1 kbit on-chip RAM Multi-chip configuration support Blanking support On-chip RC oscillator
MSC5301B-02	—	64 SEG 8 COM	1/8 (1/4 bias)	4.0 - 16.0	Serial MCU interface	100/ PQFP	1 kbit on-chip RAM Multi-chip configuration support Blanking support On-chip RC oscillator
MSM6568A	—	160 COM	1/200 - 1/480	14.0 - 28.0	2-bit shift register I/O	Slim TAB	Bidirectional 160-bit shift register Multi-chip configuration support On-chip or external bias generation
MSM6569	—	160 SEG	1/200 - 1/480	20.0 - 40.0	8-bit shift register I/O	Slim TAB	Unidirectional 160-bit shift register 160-bit latch Power-saving mode Multi-chip configuration support On-chip or external bias generation
MSM6606	—	40 SEG 2 COM	1/2	5.5	Serial MCU interface	64/ PQFP	Internal 5x6 key-scan circuit (supporting up to 30 key switches) Single LED driver output Integrated bias voltage generation On-chip RC oscillator
MSM6665-01	√	80 SEG 17 COM	1/9 or 1/17	3.0 - 6.0	Serial MCU interface	128/ PQFP	256 5x7 characters in on-chip ROM 80 dot arbiters Character and arbitrator blink functions On-chip RC oscillator
MSM6665B	√	80 SEG 17 COM	1/9 or 1/17	—	Serial MCU interface	PBGA	256 5x7 characters in on-chip ROM 80 dot arbiters Character and arbitrator blink functions Integrated bias voltage generation

For more information, see the *LCD Driver Controller Data Book* and *Advanced LCD Controller/Driver Products* from OKI Semiconductor, or contact your local OKI Semiconductor sales representative for additional assistance.