

OKI semiconductor

MSM65511

Oki Original High Performance CMOS 8 Bit 1 Chip Microcontroller

GENERAL DESCRIPTION

MSM65511 is a high-performance 8-bit single-chip controller that employs Oki's original nX-8/50 CPU core. With a minimum instruction execution time of 400 ns (10MHz clock), MSM65511 is capable of high-speed processing, and includes 4 Kbytes of program memory, 128 bytes of data memory, timers and serial ports on chip.

Program and system evaluation can be performed using MSM65P512, which as a version of MSM65512 that replaces program memory with one-time PROM. MSM65512 shares upward compatibility with MSM65511.

OPERATING RANGE

- Operating Frequency : DC ~ 10 MHz
- Operating Voltage : 4.5 ~ 5.5 V
- Operating Temperature : -40 ~ 85°C

FEATURES

- Memory Space : 8 Kbytes
 - On-Chip Program Memory : 4 Kbytes
 - On-Chip Data Memory : 128 bytes
- Minimum Instruction Execution Cycle:
400ns @ 10 MHz
- Powerful instruction set:
 - 81 basic instructions
 - 8/16-bit operation instructions
 - Bit manipulation instructions
 - Compound function instructions
- Abundant addressing modes
- I/O ports: 8-bit x 4
- Timers
 - 8-bit auto-reload timer x 2
 - Watchdog timer x 1
- Counters
 - Time base counter x 1
- Serial ports
 - Shift register x 1
- External interrupts: 2
- Interrupt factors: 6
- Package:
 - 40-pin plastic DIP
 - 44-pin plastic QFP
 - 44-pin PLCC

* Specifications are subject to change without notice.

BLOCK DIAGRAM

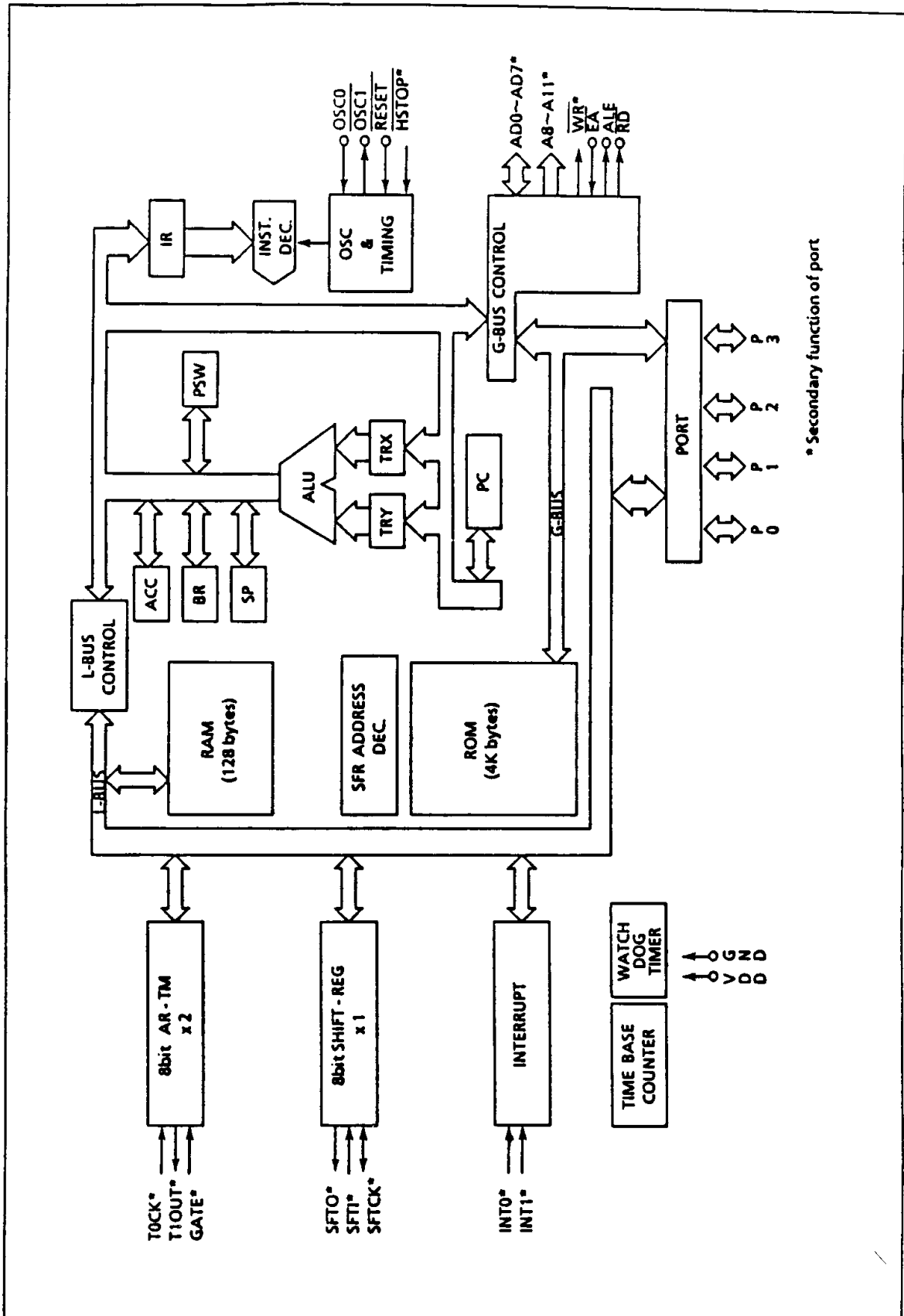

PIN CONFIGURATION

40-Pin Plastic DIP
(Top View)

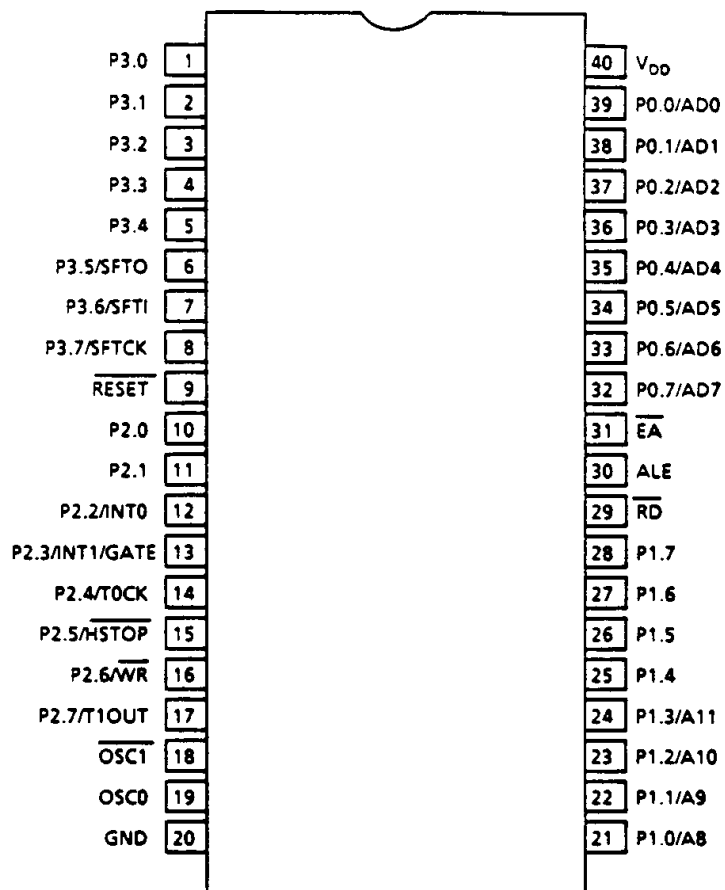

PIN DESCRIPTIONS

Type	Pin Name	I/O	Description
Power supply	VDD		+ 5 V power supply
	GND		0 V ground
Oscillation	OSC0	Input	System clock input pin. Quartz oscillator or ceramic oscillator is connected between OSC0 and $\overline{\text{OSC1}}$. For external clock, input at OSC0, leaving $\overline{\text{OSC1}}$ open.
	$\overline{\text{OSC1}}$	Output	System clock output pin
Control	$\overline{\text{RESET}}$	Input	System reset input (program starts from address 0040H); internal pull-up resistance
	$\overline{\text{EA}}$	Input	Program memory select input pin. "L" level input for external program memory; "H" level input for internal program memory.
	$\overline{\text{RD}}$	Output	Read strobe signal during external memory access
	ALE	Output	Address latch signal during external memory access
Port	PORT 0	I/O	8-bit I/O port During external memory access, becomes address/data bus for address output, instruction fetch or data read/write along with ALE, $\overline{\text{RD}}$ and $\overline{\text{WR}}$ pins
	PORT 1	I/O	8-bit I/O port Address bus during external memory access
	PORT 2 PORT 3	I/O	8-bit I/O port x2. Secondary functions shown in following table are added for ports 2 and 3.

PIN SECONDARY FUNCTIONS

Pin Name	I/O	Description
INT0	Input	P2.2 secondary function. External interrupt 0 input pin.
INT1/GATE	Input	P2.3 secondary functions. External interrupt 1 input pin. Also used as input pin for gate signal for timer 0 count enable /disable.
T0CK	Input	P2.4 secondary function Timer 0 external clock input pin.
$\overline{\text{HSTOP}}$	Input	P2.5 secondary function. Hard stop mode input pin; stops system clock oscillation with "L" level input.
$\overline{\text{WR}}$	Output	P2.6 secondary function. Write strobe signal output pin during external data memory access.
T1OUT	Output	P2.7 secondary function. Output pin for signal that 2-divided timer 1 overflow.
SFTO	Output	P3.5 secondary function. Shift register data output pin.
SFTI	Input	P3.6 secondary function. Shift register data input signal.
SFTCK	I/O	P3.7 secondary function. Shift register synchronizing clock input/output signal.

MSM65511 ELECTRICAL CHARACTERISTICS

● ABSOLUTE MAXIMUM RATINGS

Parameter	Symbol	Condition	Rating	Unit
Supply voltage	$V_{DD} = AV_{DD}$	$T_a = 25^\circ\text{C}$	- 0.3~7.0	V
Input voltage	V_I		- 0.3~ $V_{DD} + 0.3$	
Output voltage	V_O		- 0.3~ $V_{DD} + 0.3$	
Analog reference voltage	V_{RH}, V_{RL}		- 0.3~ $V_{DD} + 0.3$	
Analog input voltage	V_{AI}		- 0.3~ $V_{DD} + 0.3$	
Power dissipation	P_D	$T_a = 25^\circ\text{C}$ (per package)	400	mW
		$T_a = 25^\circ\text{C}$ (per output)	50	
Storage temperature	T_{STG}	—	- 55~ + 150	$^\circ\text{C}$

● OPERATING CONDITIONS

Parameter	Symbol	Condition	Rating	Unit
Supply voltage	V_{DD}	$f_{OSC} \leq 10\text{MHz}$	4.5 ~ 5.5	V
Memory hold voltage	V_{DDMH}	$f_{OSC} = 0\text{Hz}$	2 ~ 5.5	
Operating frequency	f_{OSC}	$V_{DD} = 5\text{V} \pm 10\%$	0 ~ 10	MHz
Operating temperature (MSM65511)	T_{OP}	—	- 40 ~ + 85	$^\circ\text{C}$

● DC CHARACTERISTICS

$V_{DD} = 5V \pm 10\%$, $GND = 0V$ $T_a = -40 \sim +85^\circ C$: MSM65511

Parameter	Symbol	Condition	MIN	TYP	MAX	Unit
"H" input voltage 1 *1	V_{IH1}	—	2.4	—	$V_{DD} + 0.3$	V
"H" input voltage 2 *2	V_{IH2}	—	$0.7V_{DD}$	—	$V_{DD} + 0.3$	
"L" input voltage	V_{IL}	—	-0.3	—	0.8	
"H" output voltage 1 *3	V_{OH1}	$I_{OH} = -200\mu A$	$0.75V_{DD}$	—	—	
"H" output voltage 2 *4	V_{OH2}	$I_{OH} = -400\mu A$	$0.75V_{DD}$	—	—	
"L" output voltage 1 *3	V_{OL1}	$I_{OL} = 1.6mA$	—	—	0.4	
"L" output voltage 2 *4	V_{OL2}	$I_{OL} = 3.2mA$	—	—	0.4	
Input leak current 1 *5	I_{IL1}	$V_I = V_{DD}/0V$	—	—	± 1	μA
Input leak current 2 *6	I_{IL2}	$V_I = V_{DD}/0V$	—	—	± 10	
"L" input current *7	I_{IL}	$V_I = 0V$	-40	-125	-250	
Input capacity	C_I	$f = 1MHz, T_a = 25^\circ C$	—	5	—	pF
Current consumption	I_{DDs}	Stop mode **	—	—	10	μA
Current consumption (MSM65511)	I_{DD}	$f_{(osc)} = 10MHz, no\ load$	—	20	40	mA

* 1: Excluding OSC0 and \overline{RESET}

* 2: OSC0 and \overline{RESET}

* 3: Excluding P0, ALE, \overline{RD} , P2.6/ \overline{WR}

* 4: P0, ALE, \overline{RD} , P2.6/ \overline{WR}

* 5: \overline{EA} , P6

* 6: Excluding \overline{RESET} , \overline{EA} , P6

* 7: \overline{RESET}

** : The ports set for input mode are V_{DD} or $0V$, $V_{RH} = V_{RL}$ and the ports except these are no load.

- AC CHARACTERISTICS

- External Memory Control

$V_{DD} = 5V \pm 10\%$, $GND = 0V$ $T_a = -40 \sim +85^\circ C$: MSM65511

Parameter	Symbol	Condition	MIN	MAX	Unit
Clock period	t_c	—	100	—	nS
"L" clock pulse width	t_{CLW}		45	—	
"H" clock pulse width	t_{CHW}		45	—	
ALE pulse width	t_{AW}	$C_L = 100pF$	$t_c + t_{CHW} - 20$	—	
\overline{RD} pulse width	t_{RW}		$t_c + t_{CHW} - 20$	—	
\overline{RD} pulse delay time	t_{RD}		$t_{CLW} - 20$	$t_{CLW} + 20$	
\overline{WR} pulse width	t_{WW}		$t_c + t_{CHW} - 40$	—	
\overline{WR} pulse delay time	t_{WD}		$t_{CLW} - 20$	$t_{CLW} + 40$	
"L" address set up time	t_{LAS}		$t_c - 40$	—	
"H" address set up time	t_{HAS}		$t_c - 40$	—	
"L" address hold time	t_{LAH}		$t_{CLW} - 20$	—	
Bus float time	t_{LAZ}		—	20	
"H" address hold time	t_{HAHR}		$t_c - 20$	—	
"H" address hold time	t_{HAHW}		$t_c - 20$	—	
Read data access time	t_{RDAA}		—	$t_c + t_{CLW} - 15$	
Read data access time	t_{RDAR}		—	$t_{CHW} + 10$	
Read data hold time	t_{RDH}		0	—	
Write data set up time	t_{WDS}		$t_c + t_{CHW} - 40$	—	
Write data hold time	t_{WDH}	$t_{CLW} - 20$	—		

● CPU Control

$V_{DD} = 5V \pm 10\%$, $GND = 0V$ $T_a = -40 \sim +85^\circ C$: MSM65511

Parameter	Symbol	Condition	MIN	MAX	Unit
RESET pulse width 1 *1	t_{RESW1}	—	20	—	nS
RESET pulse width 2 *2	t_{RESW2}	—	*3	—	—

*1 Excluding power ON, stop mode and hard stop mode

*2 In power ON, stop mode and hard stop mode

*3 Oscillation stabilization time depends on resonator

● Peripheral Control 1 (if applicable)

$V_{DD} = 5V \pm 10\%$, $GND = 0V$ $T_a = -40 \sim +85^\circ C$: MSM65511

Parameter	Symbol	Condition	MIN	MAX	Unit
OSC Clock period	t_c	—	100	—	nS
EXI External interrupt pulse width	t_{EXIW}	—	$4 t_c$	—	
T0 External clock pulse width	t_{T0CW}		$4 t_c$	—	
	GATE pulse width		t_{T0GW}	$1 t_{T0CLK}^{*3}$	
T2 External clock pulse width	t_{T2CW}		$4 t_c$	—	
CAP CAP pulse width	t_{CAPW}		$12 t_c$	—	

*1 Excluding P0, P2.6

*2 P0, P2.6

*3 t_{T0CLK} : Timer 0 count clock period selected by T0CON

● Peripheral Control 2 (if applicable)

$V_{DD} = 5V \pm 10\%$, $GND = 0V$ $T_a = -40 \sim +85^\circ C$: MSM65511

Parameter		Symbol	Condition	MIN	MAX	Unit
OSC	Clock period	t_C	—	100	—	nS
SFT	SFTCK period	t_{SFC}	$C_L = 100pF$	$8 t_C$	—	
	SFTCK "L" pulse width	t_{SFCLW}		$4 t_C - 20$	—	
	SFTCK "H" pulse width	t_{SFCHW}		$4 t_C - 20$	—	
	SFTO set up time	t_{SFOS}		$t_{SFCLW} - 100$	—	
	SFTO hold time	t_{SFOH}		$t_{SFCHW} - 100$	—	
	SFTI set up time	t_{SFIS}		100	—	
	SFTI hold time	t_{SFIH}		100	—	
SIO (Clock synchronous mode)	Synchronous clock period	t_{SIC}	$C_L = 100pF$	$8 t_C$	—	
	Synchronous clock "L" pulse width	t_{SICLW}		$4 t_C - 20$	—	
	Synchronous clock "H" pulse width	t_{SICHW}		$4 t_C - 20$	—	
	Output data set up time	t_{SIOS}		$6 t_C - 100$	—	
	Output data hold time	t_{SIOH}		$2 t_C - 100$	—	
	Input data set up time	t_{SIIS}		$t_C + t_{CLW} + 100$	—	
	Input data hold time	t_{SIIH}		0	—	

● External Memory Control

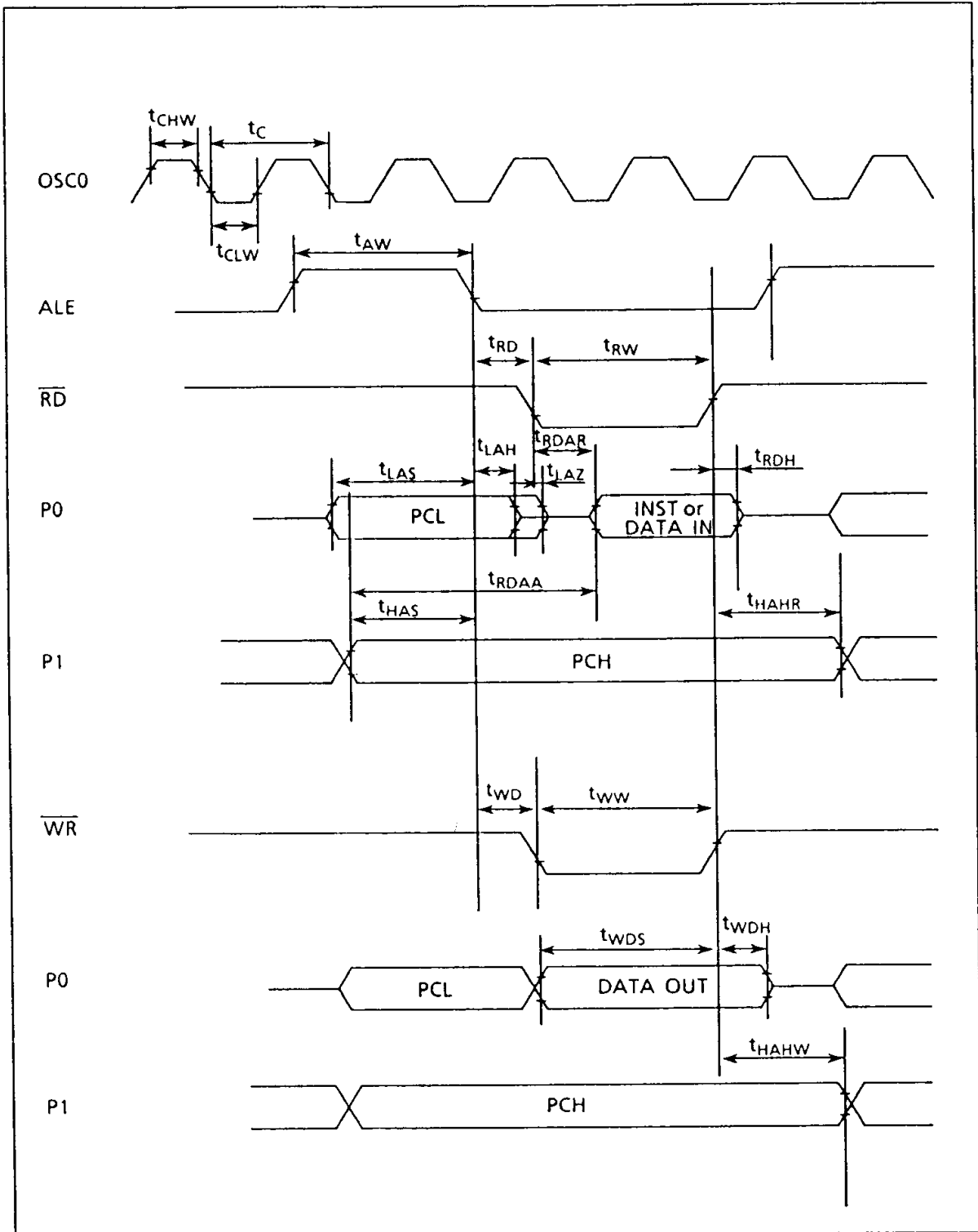

- CPU Control

1) $\overline{\text{RESET}}$ Pulse width

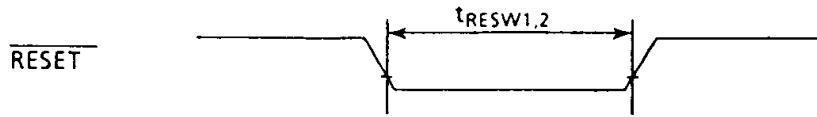

- Peripheral Control 1

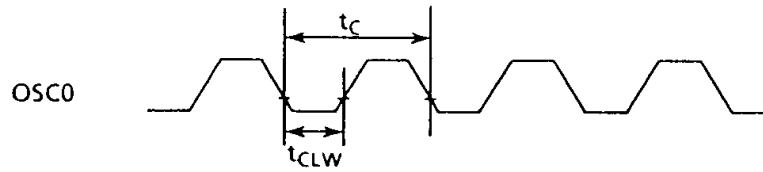

1) EXI Pulse width

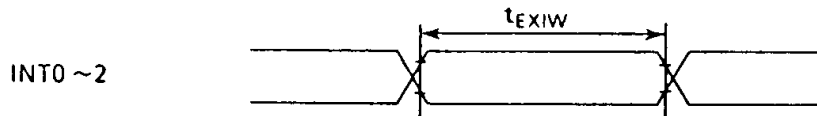

2) T0

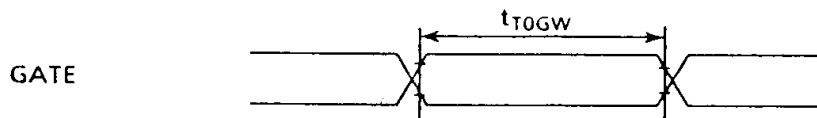
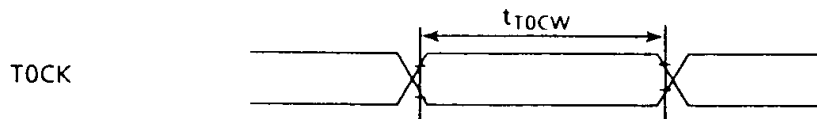

3) T2

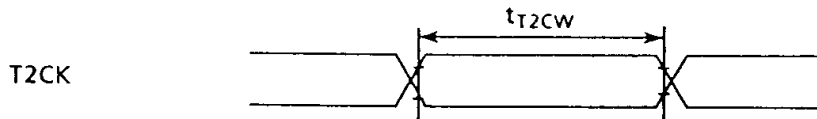

4) CAP

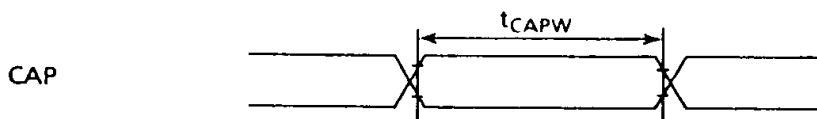

- Peripheral Control 2

1) SFT

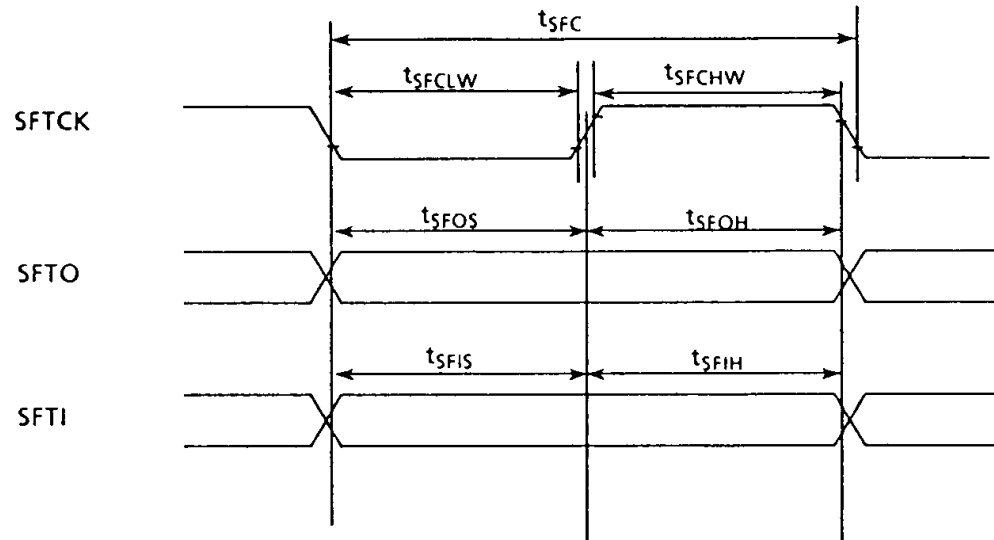

1) SIO
(Clock synchronous mode)

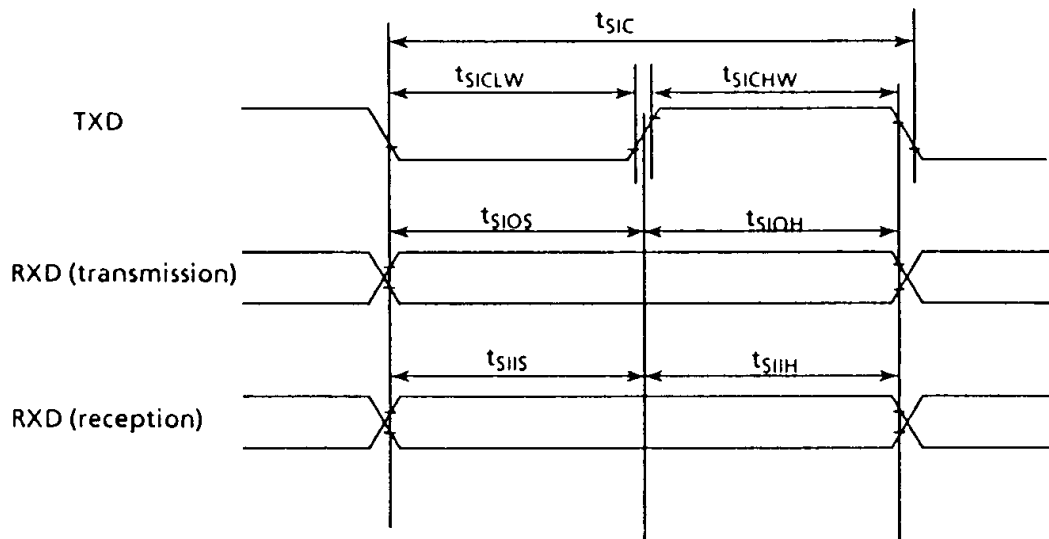

REGISTERS

- **Operation Registers**

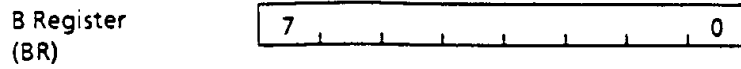
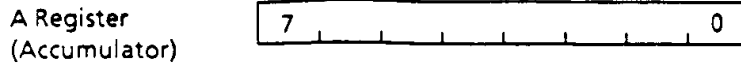

* For 16-bit operation instruction, A register holds low byte data and the B register holds high byte data.

- **Special Purpose Registers**

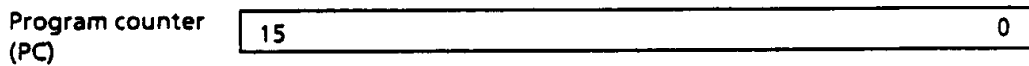
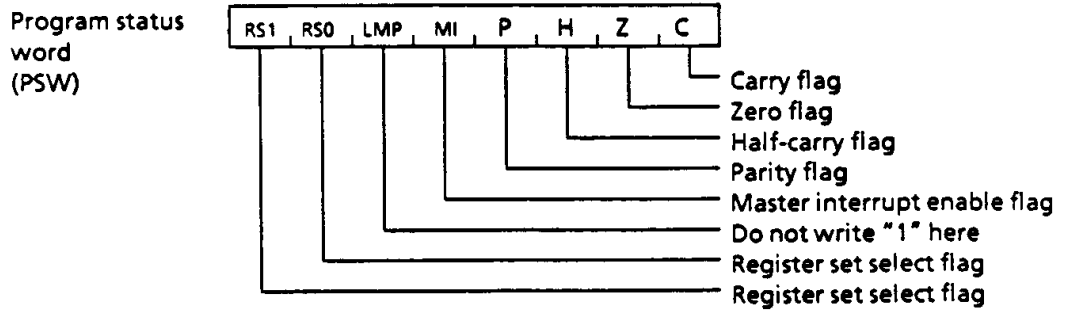
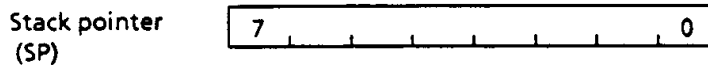

LOCAL REGISTERS

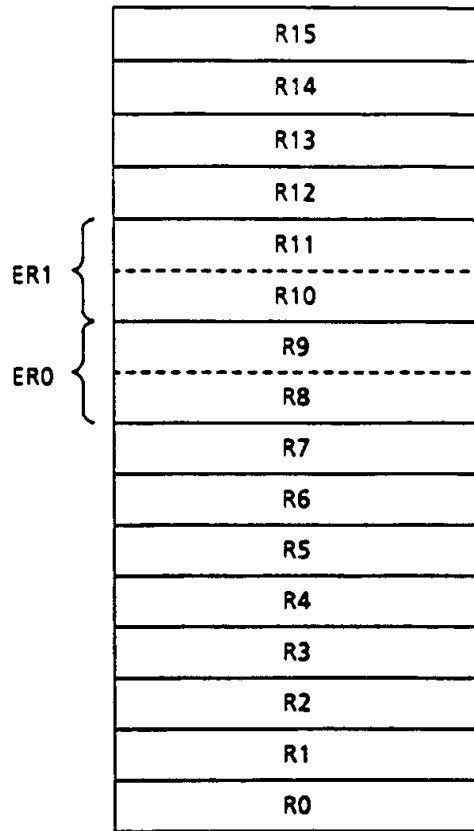

*1 4 banks of local registers are mapped in local memory space data memory.

*2 Registers R8 to R11 can be used as 16-bit registers, ER0 and ER1.

MEMORY MAPS

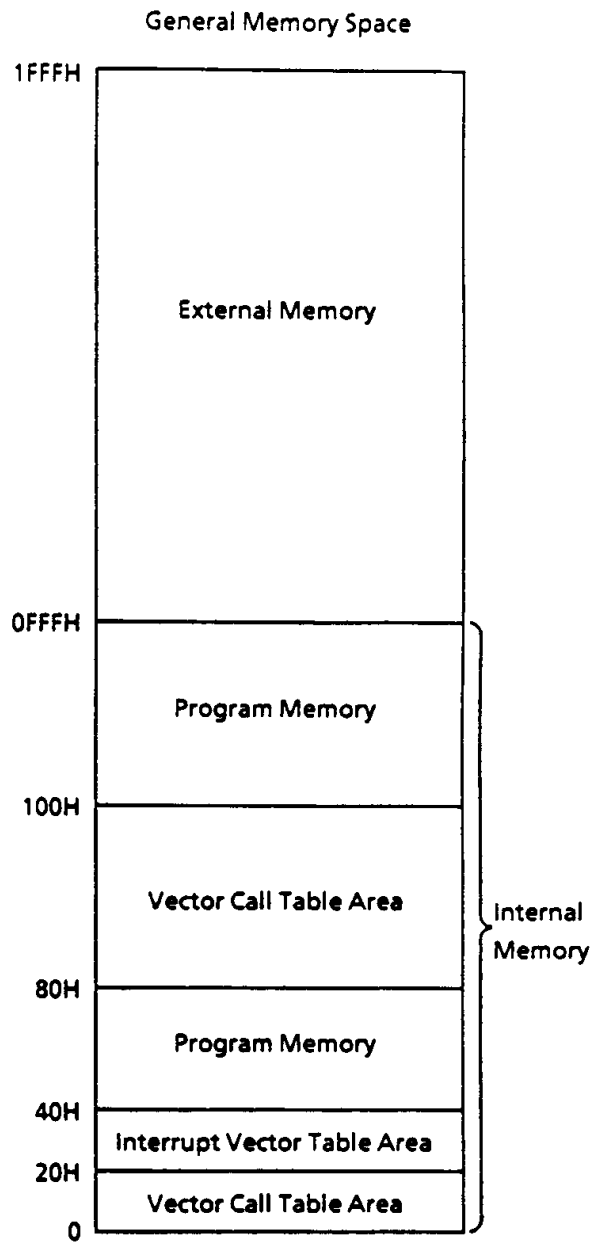
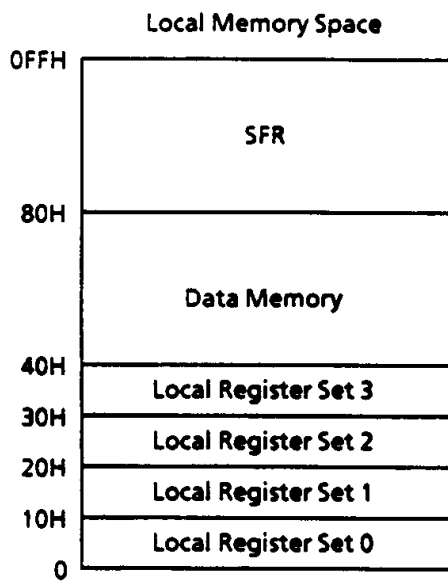

SFR TABLE

Address (HEX)	Name	Symbol	Symbol	R/W	Reset	
0F6	Interrupt enable register		IEL	R/W	00H	
0F4	Interrupt request register		IRQL		00H	
0F3	External interrupt control register		XICON		0F0H	
0F2	Standby control register		SBYCON		0F0H	
0F0	Watchdog timer control register		WDTCON	W	—	
0EE	Port 3 mode register		P3MOD	R/W	5FH	
0ED	Port 3 direction register		P3DIR		00H	
0EC	Port 3 data register		P3D		Undefined	
0EA	Port 2 mode register		P2MOD		3FH	
0E9	Port 2 direction register		P2DIR		00H	
0E8	Port 2 data register		P2D		Undefined	
0E6	Port 1 mode register		P1MOD		0FEH	
0E5	Port 1 direction register		P1DIR		00H	
0E4	Port 1 data register		P1D		Undefined	
0E3	Port 0 direction register		P0DIR		00H	
0E2	Port 0 data register		P0D		Undefined	
0E1	Shift register		SFTR		Undefined	
0E0	Shift register control register		SFTCON		0E0H	
0DF	Timer 1 register	T01R	T1R			Undefined
0DE	Timer 0 register		T0R			Undefined
0DD	Timer 1 counter	T01C	T1C			Undefined
0DC	Timer 0 counter		T0C		Undefined	
0DB	Timer 1 control register		T1CON		0F0H	
0DA	Timer 0 control register		T0CON		0E0H	
0D9	Time base counter control register		TBCON		0E0H	

ADDRESSING MODES

MSM65511 has 256 bytes of local memory space and 8 Kbytes of general memory space. A variety of addressing modes are available for accessing these spaces.

1. Register Direct Addressing

- A, B, SP, PSW
- BA

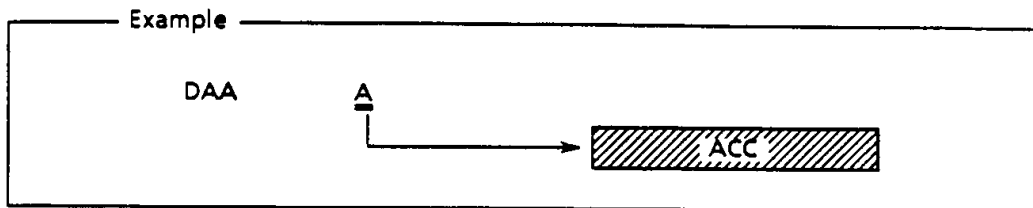

2. Local Register Direct Addressing

- Rn (n = 0~15)
- ERn (n = 0, 1)

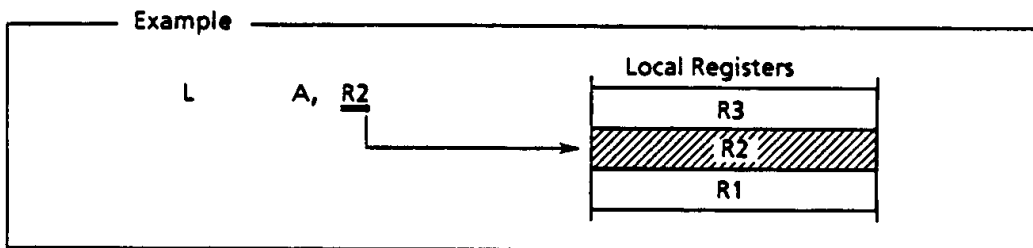

3. Local Memory Direct Addressing

- ∇ adrs

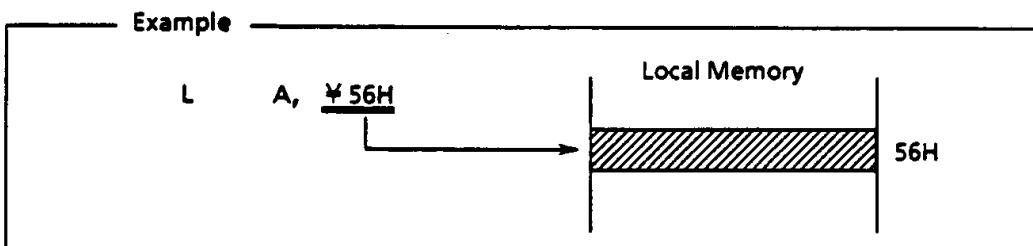

4. General Memory Direct Addressing

- adrs

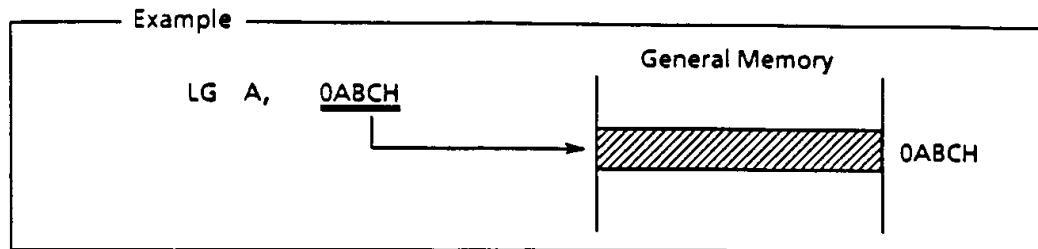

5. Local Memory - Register Indirect Addressing

- [Rn] (n = 0, 1, 8, 9)

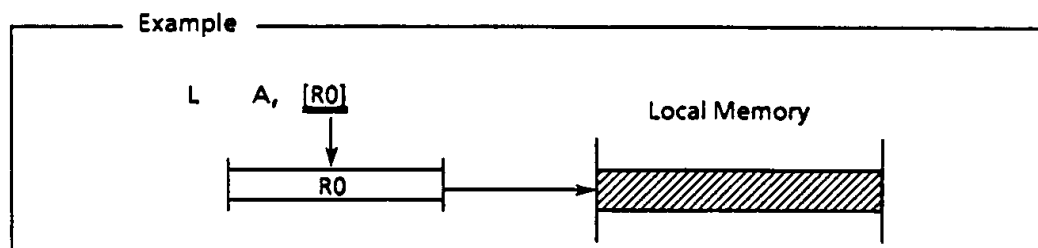

6. General Memory - Register Indirect Addressing

- [ERn] (n = 0, 1)
- [BA]

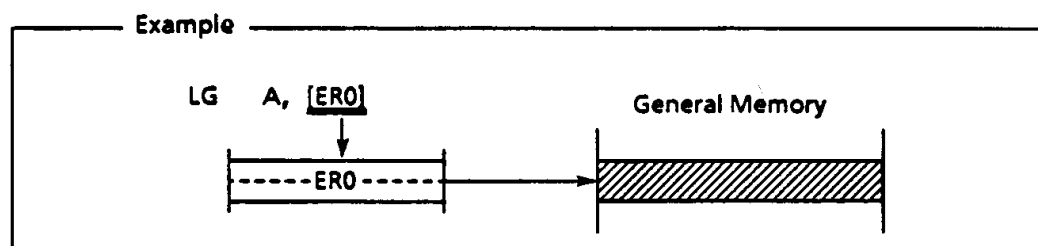

7. Local Memory Index Addressing

- `disp[Rn]` (n = 1, 9)

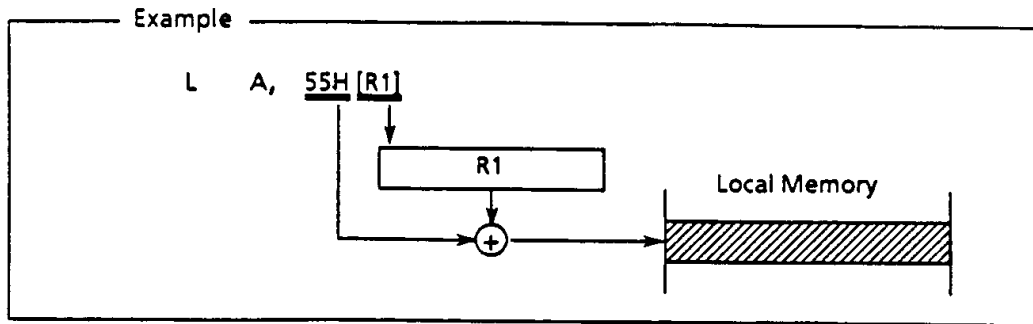

8. General Memory Index Addressing

- `disp[ER1]`

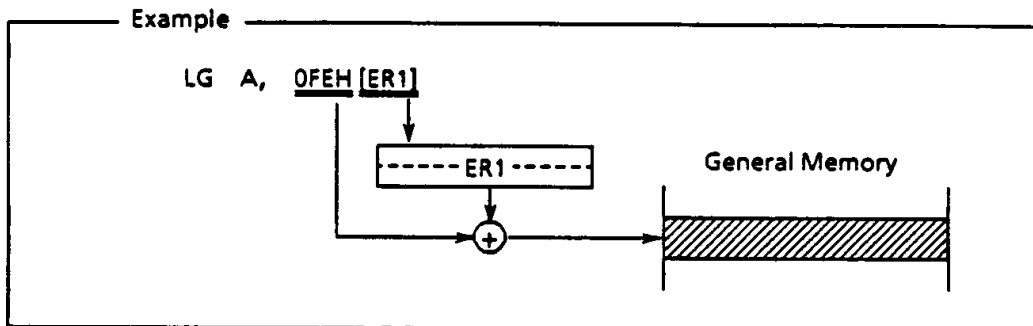

9. Immediate Addressing

- `#n`

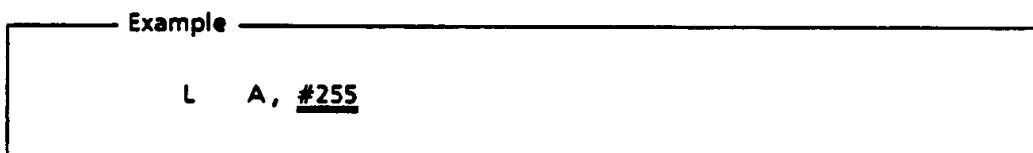

10. PC Relative Addressing

- adrs

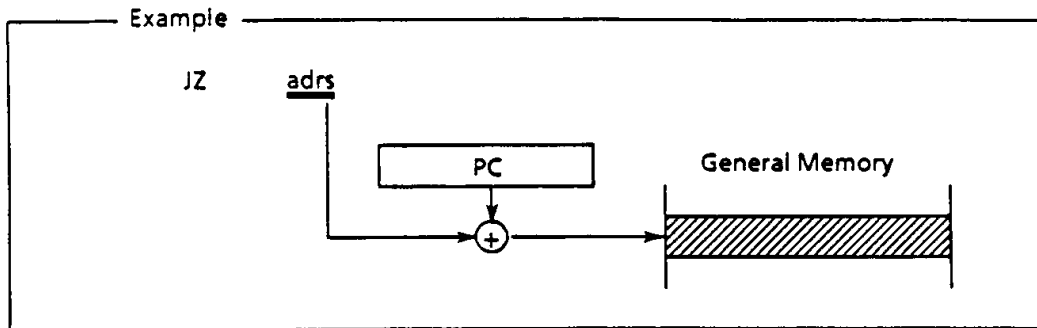

INSTRUCTION TABLES

● Data Transfer Instructions

Mnemonic		Function
L	obj1, obj2	Local memory load
LG	obj1, obj2	General memory load
ST	obj1, obj2	Store into local memory
STG	obj1, obj2	Store into general memory
MOV	PSW, #n	Immediate data transfer to PSW
MOV	obj1, obj2	Data transfer
MOVG	obj1, obj2	General memory data transfer
MOVW	obj1, obj2	16-bit data transfer
XCH	C, P	Carry and parity exchange
XCH	obj1, obj2	Data exchange
SWAP	obj	Upper nibble and lower nibble swap

● Increment and Decrement

Mnemonic		Function
INC	obj	Data increment
INCG	obj	General memory increment
INCW	obj	16-bit data increment
DEC	obj	Data decrement
DECG	obj	General memory decrement
DECW	obj	16-bit data decrement

● Arithmetic Operations

Mnemonic		Function
ADD	obj1, obj2	Data add
ADDW	obj1, obj2	16-bit data add
ADC	obj1, obj2	Data add with carry
ADCG	obj1, obj2	General memory data add with carry
SUB	obj1, obj2	Data subtract
SUBW	obj1, obj2	16-bit data subtract
SBC	obj1, obj2	Data subtract with carry
SBCG	obj1, obj2	General memory data subtract with carry

● **Comparisons**

Mnemonic		Function
CMP	obj1, obj2	Data compare
CMPW	obj1, obj2	16-bit data compare

● **Logical Operations**

Mnemonic		Function
AND	PSW, #n	PSW and immediate data logical AND
AND	obj1, obj2	Data logical AND
OR	PSW, #n	PSW and immediate data logical OR
OR	obj1, obj2	Data logical OR
XOR	obj1, obj2	Data exclusive OR

● **Bit Operations**

Mnemonic		Function
SB	obj.n	Bit set
SB	obj	PSW bit set
RB	obj.n	Bit reset
RB	obj	PSW bit reset
CPL	C	Carry complement
L	C, obj	Bit transfer to carry
ST	C, obj	Bit transfer from carry

● **Rotate and Shift**

Mnemonic		Function
ROL	obj	Rotate left
ROR	obj	Rotate right
SLL	obj	Shift left
SRL	obj	Shift right

● **Decimal Adjust**

Mnemonic		Function
DAA	obj	Decimal adjust after add
DAS	obj	Decimal adjust after subtract

● Conditional Jumps

Mnemonic		Function
JZ	adrs	Jump if zero flag is set
JNZ	adrs	Jump if zero flag is not set
JC	adrs	Jump if carry is set
JNC	adrs	Jump if carry is not set
DJZ	Rn, adrs	Decrement register, and jump if zero
DJNZ	Rn, adrs	Decrement register, and jump if not zero
JBS	obj. n, adrs	Jump if bit is set
JBR	obj. n, adrs	Jump, if bit is reset
JBSC	obj. n, adrs	Jump and clear bit if bit is set
CJE	C, P, adrs	Compare carry and parity; jump if equal
CJNE	C, P, adrs	Compare carry and parity; jump if not equal
CJE	obj1, obj2, adrs	Compare; jump if equal
CJNE	obj1, obj2, adrs	Compare; jump if not equal
CJEG	obj1, obj2, adrs	Compare with general memory data; jump if equal
CJNEG	obj1, obj2, adrs	Compare with general memory data; jump if not equal

● Jumps

Mnemonic		Function
J	adrs	Jump
SJ	adrs	Short jump
J	[BA]	Indirect jump

● Subroutines

Mnemonic		Function
PUSH	obj	Data push
POP	obj	Data pop
CAL	adrs	Subroutine call
CALZ	adrs	Call subroutine if zero flag is set
CALC	adrs	Call subroutine if carry flag is set
VCAL	n	Vector call
VCALZ	n	Vector call if zero flag is set
VCALC	n	Vector call if carry flag is set
RT		Return from subroutine
RTZ		Return from subroutine if zero flag is set
RTC		Return from subroutine if carry flag is set

● Other Instructions

Mnemonic		Function
CLR	obj	Clear
CLRW	BA	16-bit data clear
CPL	obj	Data complement
CPLW	BA	16-bit data complement
NOP		No operation
CHK	obj	Parity check
DLY	n	Program execution delay